



www.husqvarna.com



Parts Manual

Z 246 / 96727150100

Please read the operator manual carefully and make sure you understand the instructions before using the machine.

Gasoline containing a maximum of 10% ethanol (E10) is permitted for use in this machine. The use of gasoline with more than 10% ethanol (E10) will void the product warranty.

2019-05-06 JSE/SR

115 84 95-27 Rev. I



When you need spare parts or support in service questions, warranty issues, etc., please consult the following professional:

This manual belongs to the machine with the manufacturing number:	Engine	Transmission

Ref.	Part No.	Qty	Description
1	587 59 56-01	1	Decal, Steer / Brake Left
2	587 59 55-01	1	Decal, Steer / Brake Right
3	587 21 93-01	2	Decal, Z 246
4	539 10 57-45	1	Decal, Battery Warning
5	532 42 86-77	1	Decal, Crown
6	539 10 83-85	1	Decal, Do Not Tow
7	539 10 83-86	1	Decal, Exit Mower
8	539 10 98-97	1	Decal, Service
9	590 48 55-01	1	Decal, Safety Warnings
10	539 11 05-22	1	Decal, Responsibility
11	588 03 50-01	1	Decal, Start
12	581 72 44-01	1	Decal, Deflector
13	584 90 46-01	1	Decal, Blade Danger
14	510 24 02-01	1	Decal, Belt Routing
15	577 46 90-01	2	Decal, Husqvarna
16	587 00 07-01	1	Pad, Abrasive

Manufacturing Number

The machine's manufacturing number can be found on the printed plate affixed to the engine compartment.

Stated on the plate, from the top are:

- The machine's type designation (I.D.).
- The manufacturer's type number (Model).
- The machine's serial number (Serial no.)

Please have the type designation and serial number available when ordering spare parts.

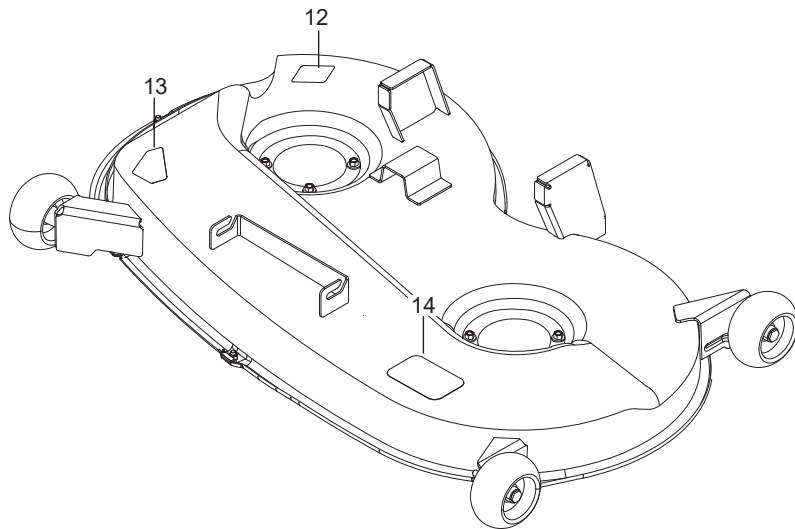
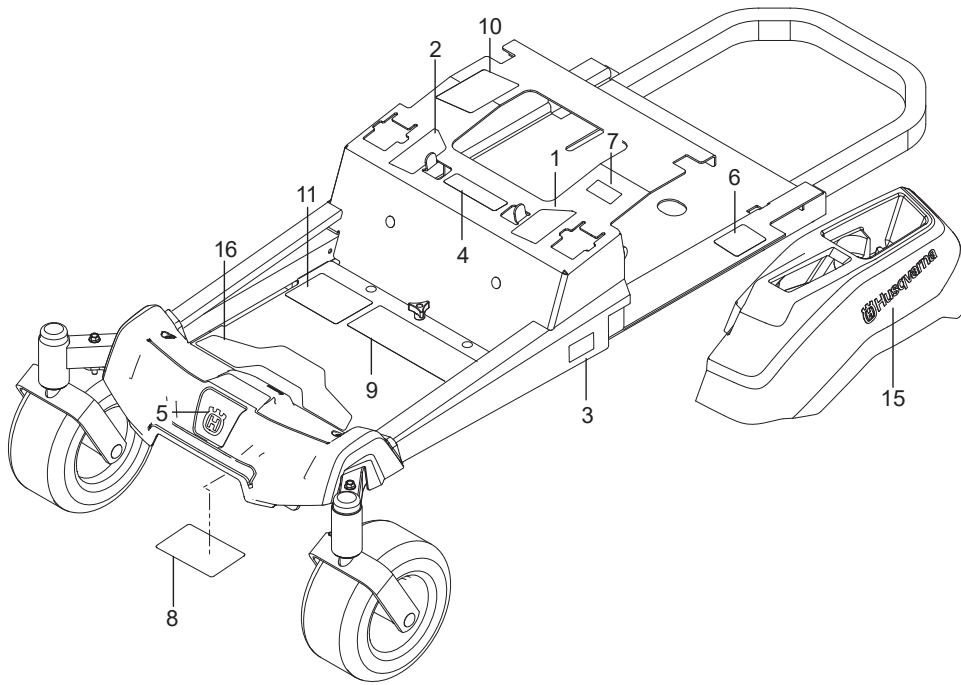

FRAME4

ENGINE MOUNTING, GUARDS & MUFFLER6

STEERING8

IGNITION SYSTEM.....10

BRAKE / LIFT12

HYDRAULIC PUMP-MOTOR..... 14

WHEELS & TIRES16

MOWER DECK / CUTTING DECK18

SEAT20

DECALS22

Illustrations may or may not represent the actual assemblies and it is not recommended to use this manual as a guide to assemble or disassemble the mower.

NOTE: All fasteners are Grade 5 unless otherwise specified.

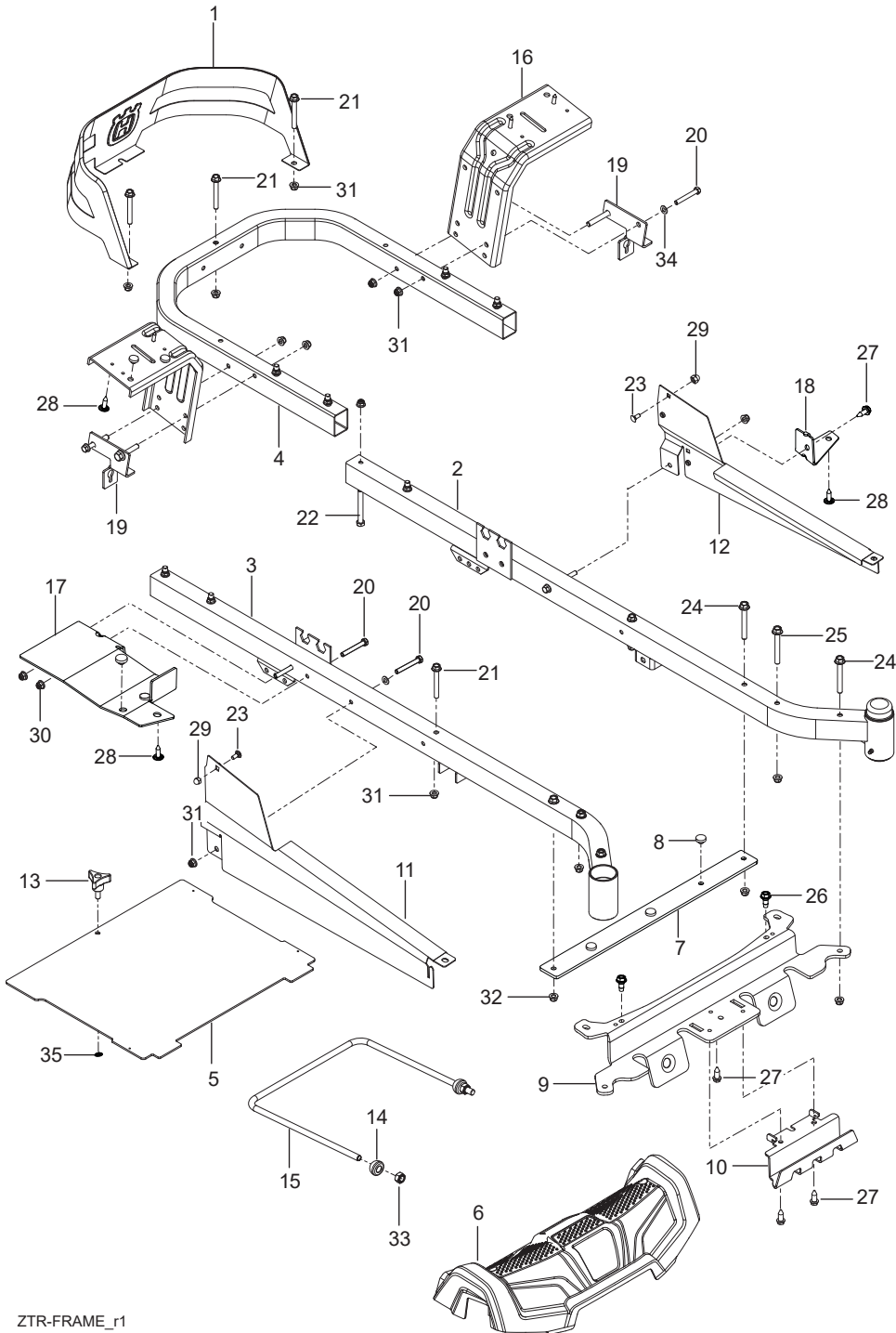

Ref.	Part No.	Qty	Description
1	532 43 98-22	1	Seat
2	587 23 20-02	1	Pan, Seat Black
3	586 22 08-02	1	Plate, Lift Support
4	586 22 12-02	1	Plate, Deck Lift
5	577 26 05-03	1	Support, Seat Orange
6	580 30 82-02	2	Support, Seat Rear Black
7	532 19 82-00	1	Spring, Latch
8	587 61 33-01	2	Spring, Seat
9	532 40 15-45	1	Switch, Seat
10	532 19 76-61	1	Handle, Slide
11	586 42 86-01	1	Leg, Support
12	585 98 93-01	2	Grommet, Bumper
13	539 10 47-63	5	Retainer, U Type
14	872 14 05-06	4	Bolt 5/16-18 x 3/4 Round Head Square Neck
15	510 42 27-01	2	Bolt 5/16-18 x 2-1/2 Round Head Square Neck
16	874 78 06-20	2	Bolt 3/8-16 x 1-1/4
17	539 10 85-03	1	Bolt 3/8-16 x 5/8
18	539 11 03-03	2	Bolt 5/16-18 Shoulder
19	817 49 05-12	4	Screw 5/16-18 x 3/4 Thread Form
20	817 00 05-10	6	Screw 5/16-18 x 5/8 Washer Head
21	539 11 28-99	4	Nut 5/16-18 Hex Flange Nyloc
22	521 99 65-01	2	Nut 3/8-16 Hex Flange Nyloc
23	539 11 18-97	1	Washer 3/8 Special
24	819 14 16-14	2	Washer 3/8 Std Flat
NOT SHOWN - OPTIONAL			
	532 42 14-99	1	Kit, Arm Rest

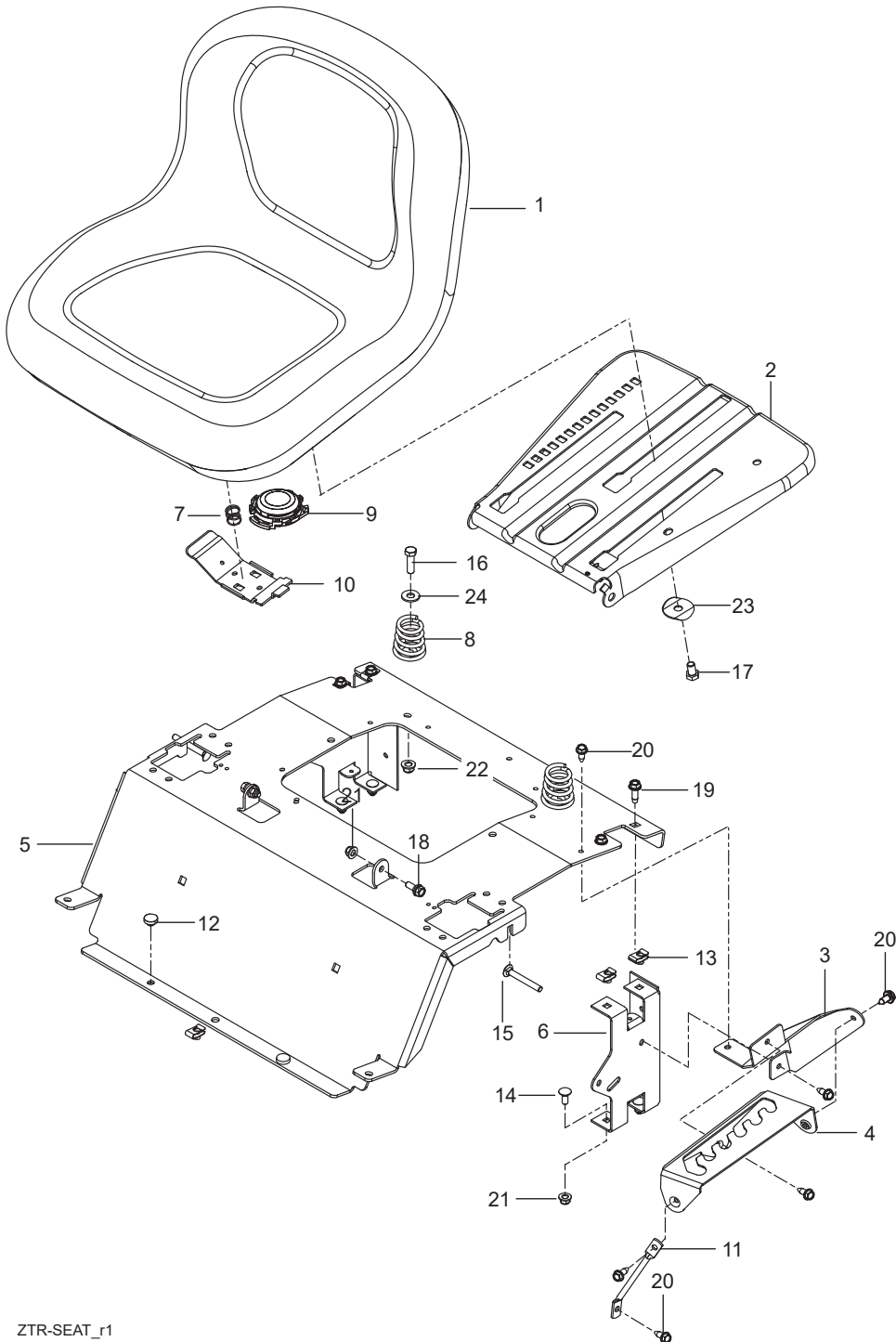

Ref.	Part No.	Qty	Description
1	585 03 98-02	1	Guard, Rear Black
2	589 28 34-02	1	Frame, Front Right Orange
3	589 28 33-02	1	Frame, Front Left Orange
4	584 99 10-02	1	Frame, Rear Tube Orange
5	522 84 29-02	1	Foot Plate w/ Safety Decal
6	585 52 24-01	1	Cover, Footrest
7	585 52 30-04	1	Support, Footrest
8	585 98 93-01	7	Grommet, Bumper
9	585 52 31-04	1	Cross Member
10	585 52 32-04	1	Plate, Skid Silver
11	585 33 16-02	1	Cover, Rail Right
12	585 33 15-02	1	Cover, Rail Left
13	539 10 44-11	1	Knob w/ Stud
14	532 19 52-63	2	Bushing, Pivot
15	521 93 81-01	1	Link, Front Suspension
16	580 50 13-02	2	Support, Fender Black
17	585 52 34-04	1	Support, Console Right
18	585 52 36-04	1	Support, Console Left
19	585 47 43-02	2	Bracket, Bypass Rod
20	874 78 05-36	8	Bolt 5/16-18 x 2-1/4
21	874 49 05-44	5	Bolt 5/16-18 x 2-3/4
22	874 78 06-48	8	Bolt 3/8-16 x 3
23	585 94 00-01	2	Bolt 5/16-18 x 1 Carriage
24	577 11 77-01	4	Bolt 3/8-16 x 3
25	586 65 43-01	2	Bolt 3/8-16 x 3 Shoulder
26	586 88 11-01	2	Bolt 5/16-18 Shoulder
27	817 00 05-10	4	Screw 5/16-18 x 5/8 Washer Head
28	532 41 63-58	6	Screw #10-24 x 3/4 Hex Head
29	585 93 81-01	2	Nut 5/16-18 Acorn
30	873 90 05-00	2	Nut 5/16-18 Hex Flange Lock
31	539 11 28-99	9	Nut 5/16-18 Hex Flange Nyloc
32	521 99 65-01	8	Nut 3/8-16 Hex Flange Nyloc
33	539 11 91-24	2	Nut 7/16-14 Hex Nyloc
34	819 11 11-16	6	Washer 5/16 Sae Flat
35	532 42 30-63	1	Palnut 5/16"

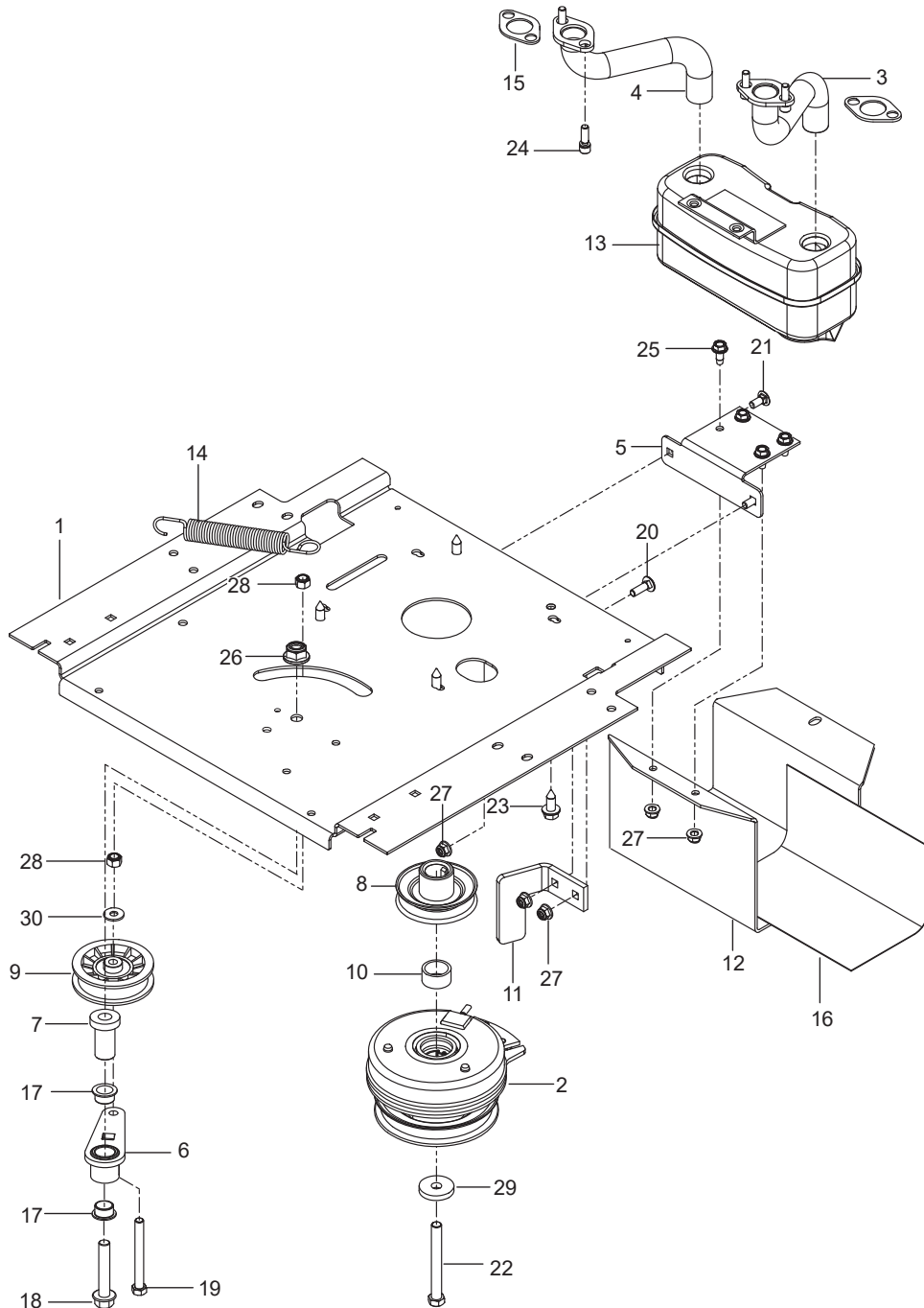

Ref.	Part No.	Qty	Description
1	522 74 43-01	1	Deck w/ Safety Decals Orange
2	539 11 72-45	1	Belt, Deck
3	532 40 53-80	2	Blade, Hi-Lift
4	532 40 55-06	1	Shield, Belt Right
5	597 68 33-01	1	Shield, Belt Left
6	589 52 73-01	3	Wheel, Gauge
7	522 62 97-01	1	Keeper, Belt
8	532 19 61-04	1	Pulley, Idler
9	589 76 61-01	1	Pulley, Idler
10	588 58 66-01	2	Pulley, Deck
11	582 50 40-01	1	Spring, Deck Belt
12	532 17 81-02	1	Spring, Torsion
13	539 11 87-62	1	Spring
14	532 41 64-05	1	Coupling, Connect
15	532 41 55-98	1	Port, Washout
16	532 40 31-49	1	Baffle, Front
17	532 40 31-50	1	Baffle, Front Right
18	532 19 25-57	1	Bracket, Deflector
19	532 40 53-57	1	Shield, Deflector
20	587 12 52-01	2	Mandrel
21	539 11 20-76	1	Bushing, Idler
22	585 32 39-01	1	Bearing
23	587 25 56-01	1	Shaft
24	532 13 14-91	1	Rod, Hinge
25	588 09 64-02	1	Arm, Idler
26	501 06 35-02	1	Plate Front
27	585 31 78-05	1	Plate, Side
28	539 11 55-74	1	Eyebolt 5/16 x 3-1/2
29	532 19 51-61	2	Stud w/ Anti- Rotate
30	532 19 34-06	3	Bolt 3/8-16 x 3-5/8 Shoulder
31	539 11 36-21	2	Bolt 3/8-16 x 3/8 Shoulder
32	584 30 93-01	2	Bolt, Washer
33	872 11 06-18	1	Bolt 3/8-16 x 2-1/4 Round Head Square Neck
34	872 14 05-06	6	Bolt 5/16-18 x 3/4 Round Head Square Neck
35	874 78 07-40	1	Bolt 7/16-14 x 2-1/2 Hex Head
36	874 52 05-20	1	Bolt 5/16-18 x 1-1/4 Hex Head
37	539 99 10-34	1	Screw 10-24 x 5/8 Washer Head
38	584 95 39-01	8	Bolt 5/16-18 Washer Head
39	532 13 77-29	4	Screw 1/4-20 x 5/8 Thread Roll
40	578 29 64-04	6	Screw 1/4-20 Button Head
41	532 11 04-52	1	Pushnut
42	539 99 05-85	2	Nut 5/16-18 Hex Whiz Lock
43	539 20 02-82	3	Nut 3/8-16 Hex Jam Nyloc
44	532 40 02-34	2	Nut 9/16 Top Center Lock
45	873 90 07-00	1	Nut 7/16-14 Hex Nyloc
46	873 90 06-00	3	Nut 3/8-16 Flange Lock
47	539 11 28-99	3	Nut 5/16-18 Hex Flange Nyloc
48	873 80 05-00	8	Nut 5/16-18 Hex Nyloc
49	873 90 04-00	6	Nut 1/4-20 Hex Flange
50	819 21 21-13	2	Washer 5/8 SAE Flat
51	539 99 06-92	3	Washer 12 Gauge
52	539 10 95-62	2	Washer 3/8
53	539 10 48-64	1	Washer 7/16

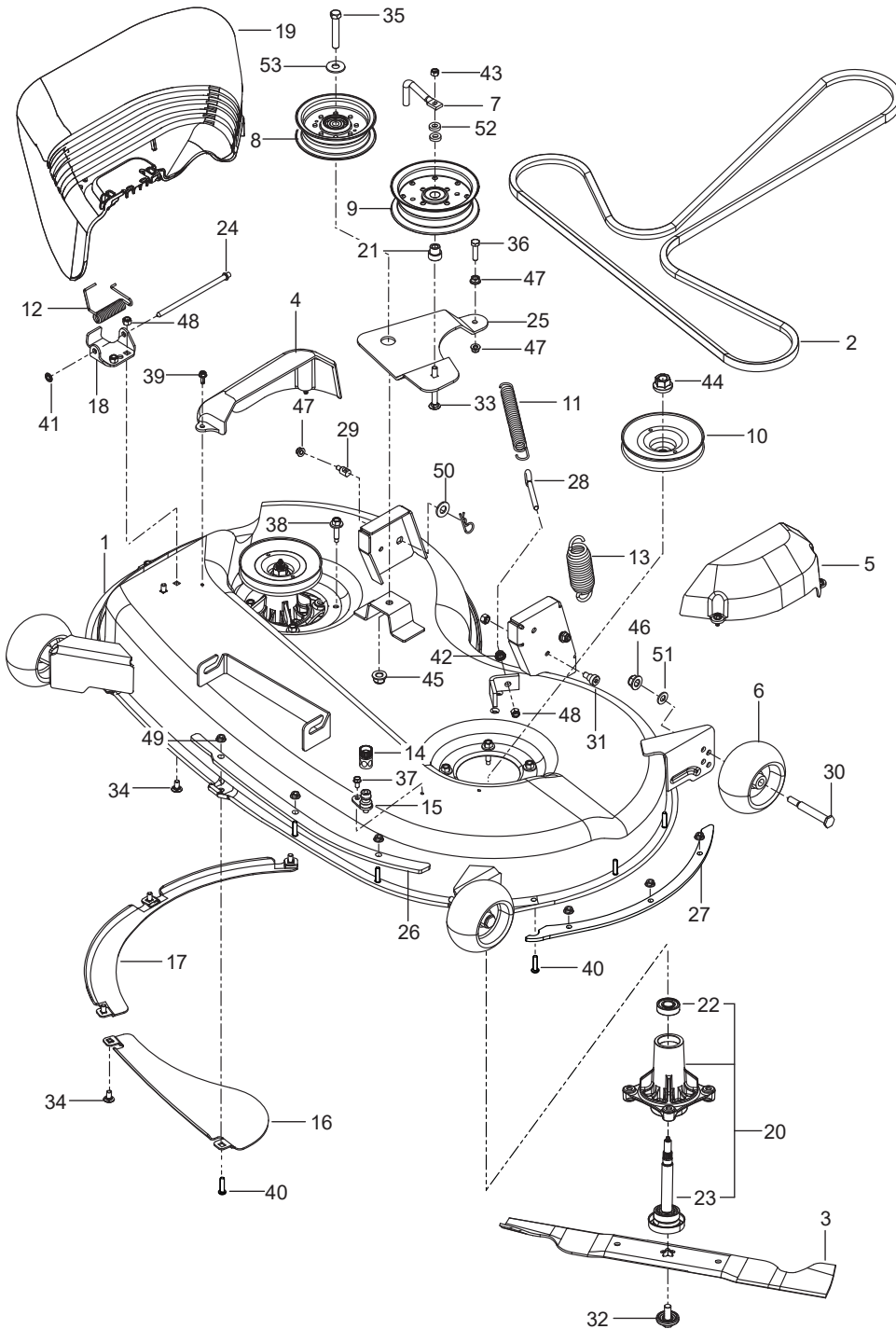

Ref.	Part No.	Qty	Description
1	588 01 71-02	1	Plate, Engine Blk
2	585 52 11-01	1	Clutch
3	581 88 11-01	1	Tube, Exhaust Left
4	581 88 10-01	1	Tube, Exhaust Right
5	581 88 67-02	1	Bracket, Muffler Blk
6	532 44 81-45	1	Arm, Idler
7	582 53 89-01	1	Spindle, Idler
8	587 53 74-01	1	Pulley, Engine
9	539 11 03-11	1	Pulley, Idler
10	539 11 22-52	1	Spacer
11	510 24 60-02	1	Stop, Clutch Blk
12	587 45 12-02	1	Guard, Muffler Blk
13	539 13 16-04	1	Muffler Assembly
14	532 19 61-05	1	Spring, Deck Drive
15	532 16 53-91	2	Gasket, Muffler
16	539 13 28-59	1	Shield, Heat
17	501 60 37-01	2	Bearing, Flanged
18	582 53 95-01	1	Bolt 1/2-13 x 2-3/4 Hex Flange Head
19	874 52 06-56	1	Bolt 3/8-16 x 3-1/2 Hex Head
20	539 99 02-08	2	Bolt 5/16-18 x 1 Round Head Square Neck
21	872 14 05-06	2	Bolt 5/16-18 x 3/4 Round Head Square Neck
22	581 33 28-04	1	Bolt 7/16-20 x 3-1/2 Hex Head
23	817 12 06-16	4	Screw 3/8-16 x 1 Thread Form
24	532 18 39-06	4	Screw 5/16-18 x 1 Socket Head
25	817 49 05 12	4	Screw 5/16-18 x 3/4 Thread Form
26	521 99 11-01	1	Nut 1/2-13 Hex Flange Nyloc
27	539 11 28-99	5	Nut 5/16-18 Hex Flange Nyloc
28	539 97 69-79	2	Nut 3/8-16 Hex Nyloc
29	532 12 61-97	1	Washer, Clutch
30	539 99 06-92	2	Washer 5/16 Std Flat
	NOT SHOWN		
	589 54 39-01	1	Idler Arm Kit
	-----	1	Engine, Briggs & Stratton 40S777 20 HP For Engine Replacement Parts, See a B&S Dealer

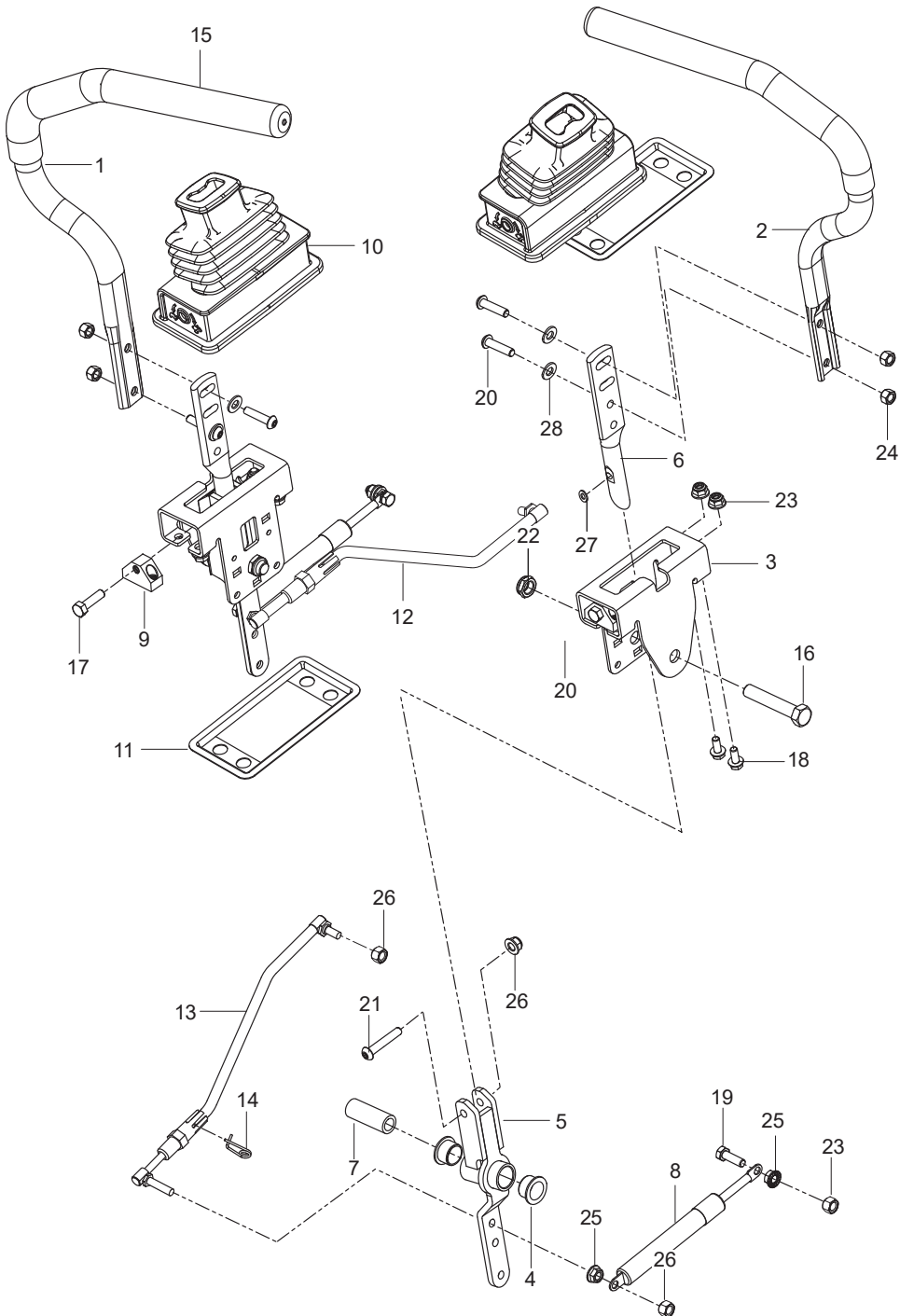

Ref.	Part No.	Qty	Description
1	590 48 66-01	2	Assy, Wheel Rear 18 x 9.5
2	590 48 68-02	2	Wheel Assy Caster 11 x 4.5
3	510 18 65-05	2	Yoke Orange
4	539 11 56-38	2	Zerk 3/16 Drive
5	539 10 33-00	2	Zerk
6	539 11 26-60	2	Bearing, Flanged
7	539 11 79-01	2	Bushing, Caster
8	539 10 25-35	2	Grease Cap
9	539 11 57-49	2	Plug, Caster
10	539 11 57-47	2	Spring, Caster
11	581 26 92-01	2	Spacer 5/16
12	576 58 89-01	2	Spacer, Split
13	874 95 05-16	2	Bolt, Hex 5/16-18 x 1 Nyloc
14	721 40 81-04	2	Bolt 1/2-13 x 6-1/2 Round Head Square Neck
15	873 93 08-00	2	Nut 1/2-13 Hex Center Lock
16	587 65 39-02	8	Nut 1/2 Lug
17	539 11 56-75	2	Washer
18	819 18 22-12	2	Washer 9/16

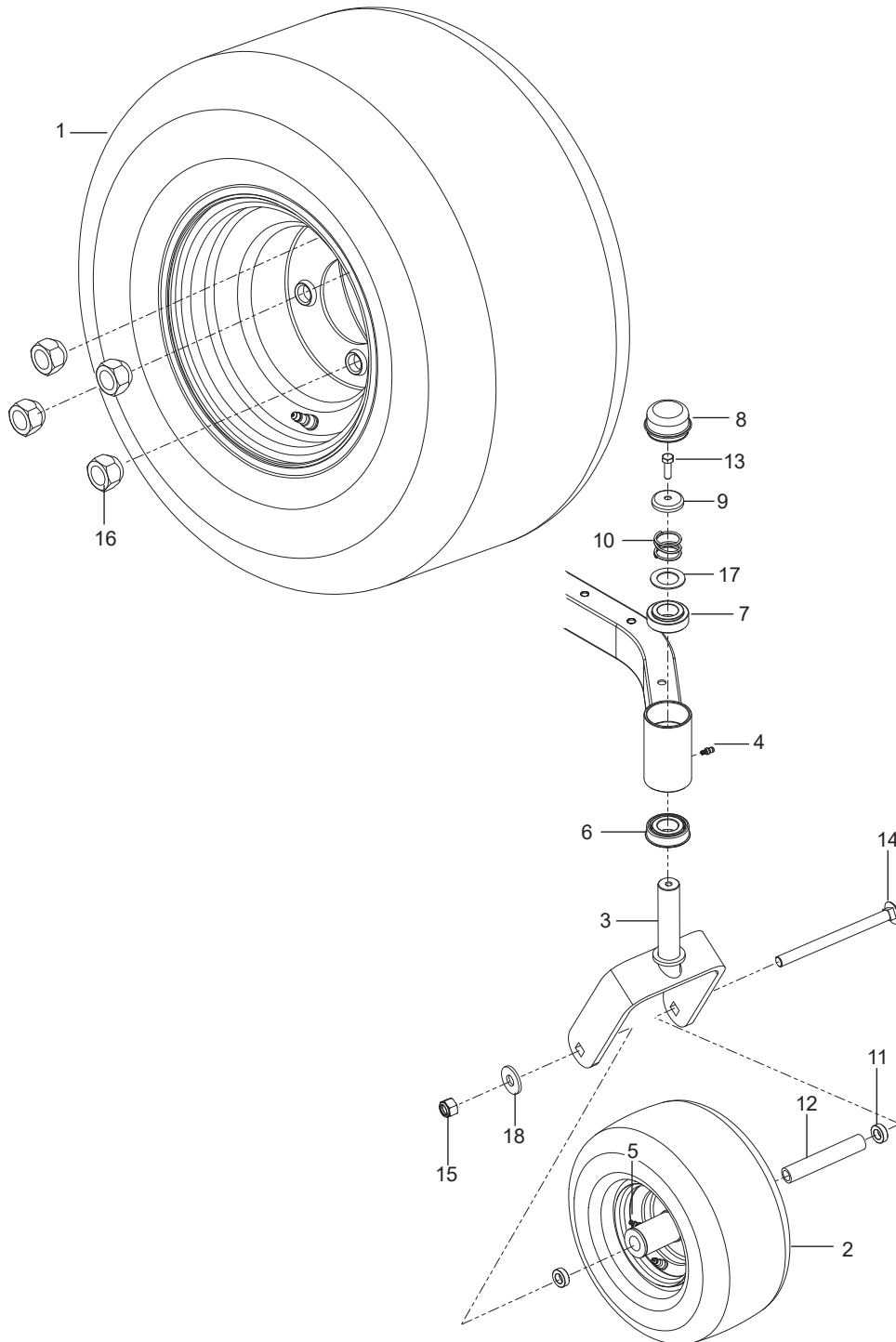

Ref.	Part No.	Qty	Description
1	590 09 08-03	1	Lever w/ Grip Right Blk
2	590 09 08-04	1	Lever w/ Grip Left Blk
3	585 12 47-05	2	Bracket, Control
4	539 13 15-18	4	Bearing, Flanged
5	576 14 03-01	2	Control, Lever
6	587 60 17-02	2	Lever, Handle
7	584 92 72-01	2	Spacer, Pivot Control
8	539 10 27-20	2	Dampener
9	581 43 75-01	2	Block, Tracking
10	585 83 16-01	2	Boot, Steering
11	585 48 82-02	2	Flange, Boot
12	588 60 49-01	2	Assy, Right Control Linkage
13	588 60 50-01	2	Assy, Left Control Linkage
14	532 19 98-49	2	Clip, Spring
15	525 39 29-02	2	Grip, Foam
16	874 78 08-44	2	Bolt 1/2-13 x 2-3/4 Hex Head
17	585 98 61-01	2	Bolt 5/16-18 x 1-1/4 Hex Head
18	874 49 05-12	8	Bolt Hex Flange 5/16-18 x 3/4
19	539 99 02-09	2	Bolt 5/16-18 x 1 Thread Form
20	585 98 59-01	4	Screw 5/16-18 x 1-1/4 Button Head Blk
21	576 85 04-02	2	Screw 5/16-18 x 1-3/4 Button Head
22	539 10 80-10	2	Nut 1/2-13 Hex Jam Nyloc Grade 2
23	539 11 28-99	10	Nut 5/16-18 Hex Flange Nyloc
24	585 98 60-01	4	Nut 5/16-18 Hex Nyloc Blk
25	539 99 05-85	4	Nut 5/16-18 Hex Whiz Lock
26	873 80 05-00	4	Nut 5/16-18 Hex Nyloc
27	587 61 42-01	2	Washer 11/32
28	819 11 11-16	4	Washer 11/32

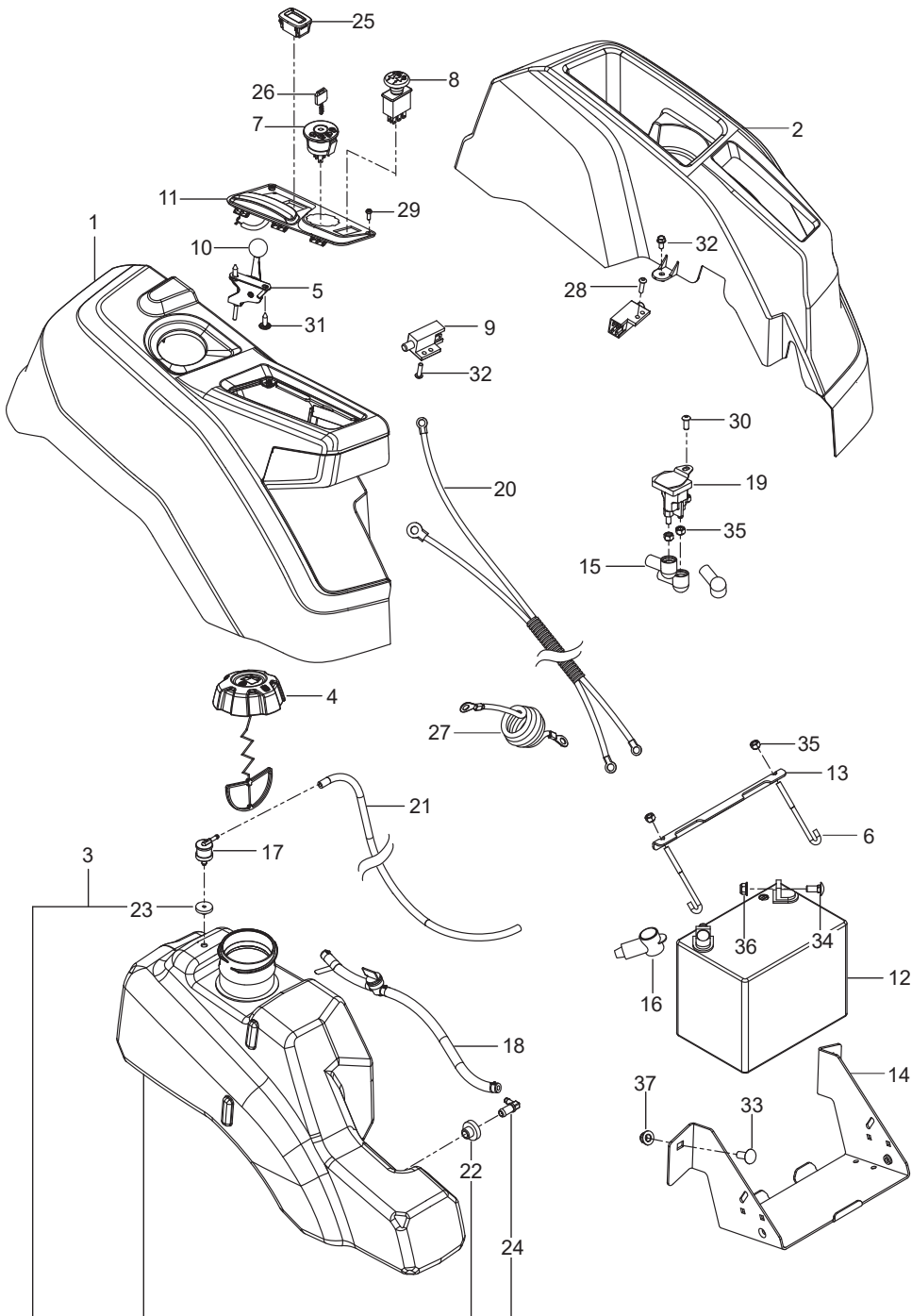

Ref.	Part No.	Qty	Description
1	510 37 56-01	1	EZT, Left
2	510 37 56-02	1	EZT, Right
3	574 03 05-01	1	Rod, EZT Brake Left
4	574 03 05-02	1	Rod, EZT Brake Right
5	539 11 04-11	1	Belt, EZT
6	585 47 44-01	1	Rod, Bypass Left
7	585 47 45-01	1	Rod, Bypass Right
8	586 66 51-01	2	Spring, Bypass
9	539 11 03-42	2	Spring, Brake Rod
10	539 12 00-80	2	Cog, Brake Disc
11	539 12 00-79	2	Assembly Kit, Brake Arm
12	575 50 70-01	1	Assembly Kit, Hub w/ Nuts
13	501 40 36-02	2	Assembly Kit, Blade, Pulley
14	510 18 41-04	2	Spacer Tube
15	580 80 65-02	2	Support, EZT Front
16	580 80 66-02	2	Mount, EZT Rear Black
17	587 22 53-01	1	Clip
18	539 97 69-88	4	Clip
19	587 11 53-01	1	Pin, Clevis
20	874 78 05-44	4	Bolt 5/16-18 x 2-3/4
21	539 97 69-34	2	Bolt 5/16-18 x 3/4
22	874 78 05-36	2	Bolt 5/16-18 x 2-1/4
23	539 99 06-37	4	Bolt 3/8-16 x 2-1/2
24	873 80 05-00	8	Nut 5/16-18 Hex Nyloc
25	539 97 69-78	2	Nut 1/4-20 Hex Nyloc
26	819 11 11-16	16	Washer 5/16 SAE Flat
27	810 03 06-00	4	Washer 3/8 Splt Lock
28	819 13 13-16	8	Washer 3/8 SAE Flat
29	819 09 10-16	4	Washer 1/4 SAE Flat

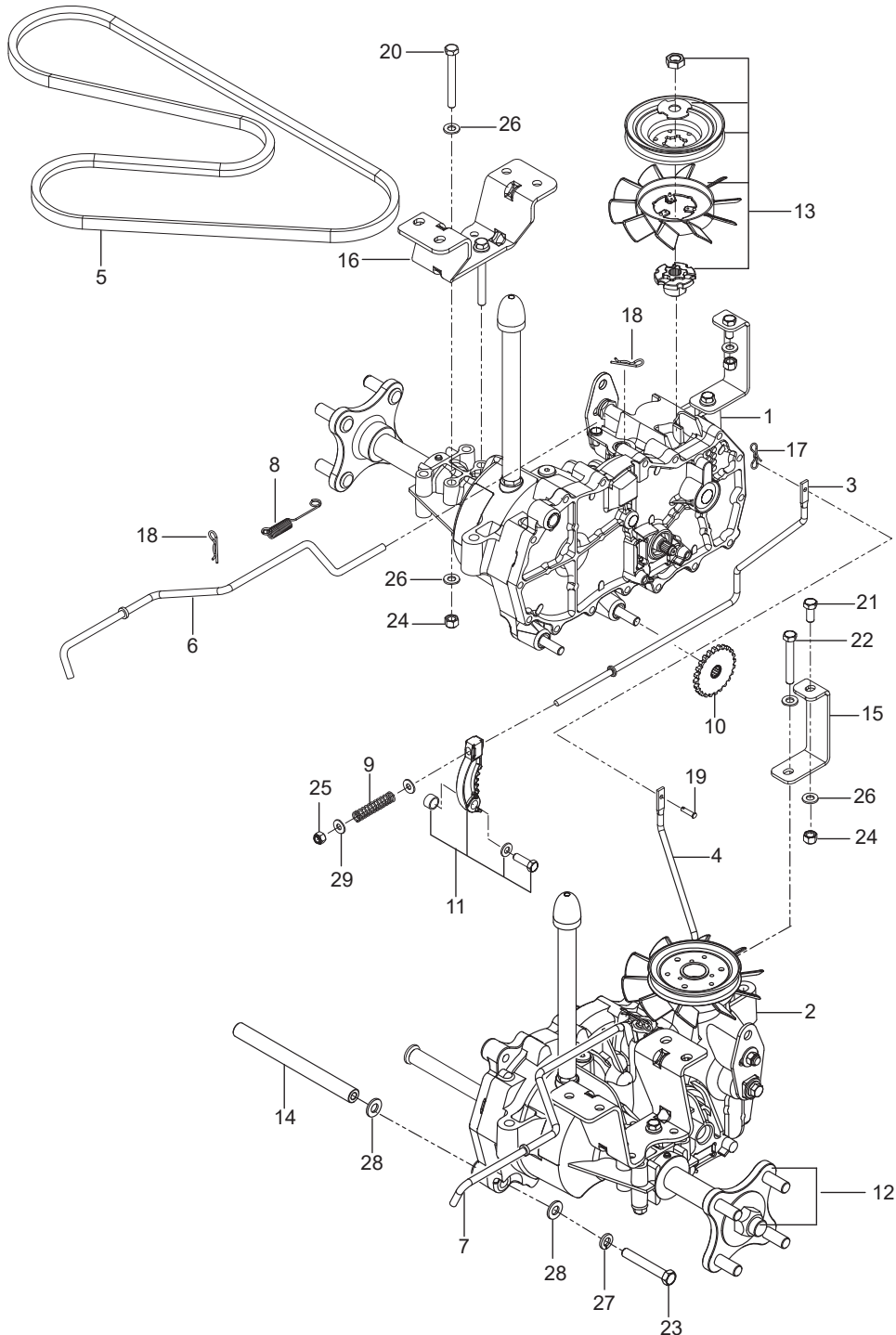

Ref.	Part No.	Qty	Description
1	585 52 28-01	1	Assembly, Fender, Right Gry
2	586 62 12 01	1	Assembly, Fender, Left Gry
3	578 18 06-02	1	Assembly, Fuel Tank
4	585 12 48-01	1	Cap, Fuel w/ Tether
5	585 97 49-02	1	Cable, Throttle
6	588 83 94-01	2	J Hook
7	539 10 75-41	1	Switch, Ignition
8	582 10 76-02	1	Switch, Clutch
9	587 60 15-01	2	Switch, Interlock
10	539 13 30-49	1	Knob
11	585 52 27-03	1	Panel, Control
12	579 41 16-01	1	Battery
13	510 03 00-03	1	Bracket, Battery
14	582 60 96-02	1	Box, Battery Blk
15	532 13 15-63	3	Terminal Cover
16	539 10 27-59	1	Terminal Cover
17	576 61 81-01	1	Valve, Fuel Check
18	586 12 39-04	1	Assembly, Fuel Line w/ Valve
19	582 04 28-01	1	Solenoid
20	587 19 86-01	1	Harness, Battery Cable
21	587 04 45-18	1	Hose 3/16 x 18" Vapor
22	532 00 36-45	1	Grommet, Rubber
23	532 43 74-92	1	Grommet, Check Valve
24	532 13 92-77	1	Elbow
25	586 16 18-01	1	Meter, Service
26	532 14 04-01	1	Key, Ignition
27	539 10 33-06	1	Cable, Battery Positive
28	586 93 60-01	2	Screw #10-24 x 1/2 Socket Head
29	545 22 71-01	2	Screw 6-19 x 7/16 Pan Head
30	539 11 12-29	1	Screw 1/4-20 x 5/8 Button Socket
31	532 14 18-41	2	Screw 10-16 x .65
32	817 49 04-08	2	Bolt 1/4-20 x 1/2
33	539 99 06-45	2	Bolt 3/8-16 x 1 Round Head Square Neck
34	872 14 05-06	2	Bolt 5/16-18 x 3/4 Round Head Square Neck
35	539 97 69-78	5	Nut 1/4-20 Hex Nyloc
36	539 11 28-99	2	Nut 5/16-18 Flange Nyloc
37	521 99 65-01	2	Nut 3/8-16 Hex Flange Nyloc
NOT SHOWN			
	586 33 73-01	1	Harness, Wiring
	532 10 97-48	1	Relay 40A

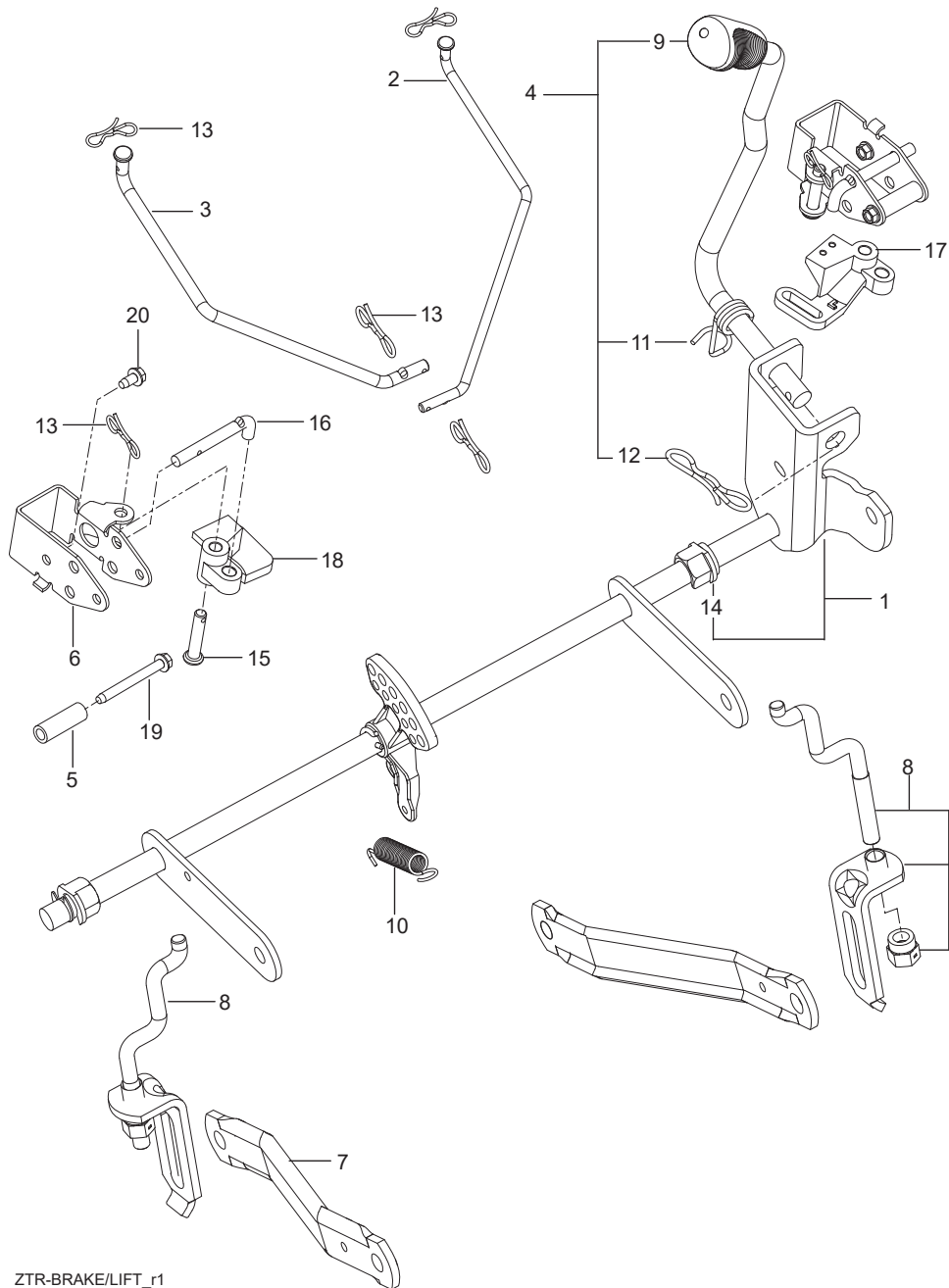

Ref.	Part No.	Qty	Description
1	587 62 31-01	1	Assembly, Shaft w/ Nuts, E-Rings
2	586 45 71-01	1	Link, Brake Left
3	586 45 72-01	1	Link, Brake Right
4	587 62 29-01	1	Assembly, Lift Handle
5	580 48 61-01	2	Spacer
6	585 68 21-01	2	Bracket, Bellcrank
7	532 19 51-85	2	Arm, Suspension
8	587 62 30-01	2	Assembly, Centering Lnk
9	532 44 50-60	1	Grip, Handle
10	586 86 76-01	1	Spring
11	532 19 63-14	1	Spring
12	532 19 42-09	1	Clip
13	587 22 53-01	6	Clip
14	510 18 49-01	2	Nut, Plastic
15	585 70 14-01	2	Pin 1/2 Clevis
16	585 68 20-01	2	Pushrod
17	586 45 74-01	1	Bellcrank Left
18	586 45 75-01	1	Bellcrank Right
19	586 56 13-01	2	Screw 1/4-20 x 2-1/4 Thread Roll
20	532 13 77-29	2	Screw 1/4-20 x 5/8 Thread Roll

ZTR-BRAKE/LIFT_r1