

ILLUSTRATED PARTS LIST

MODEL NUMBER ST 430

PRODUCT NUMBER 961 93 01-31

MFG. ID. NUMBER 96193013101

REPAIR PARTS

AUGER HOUSING / IMPELLER ASSEMBLY

SNOW THROWER - MODEL NO. ST 430 (96193013101), PRODUCT NO. 961 93 01-31

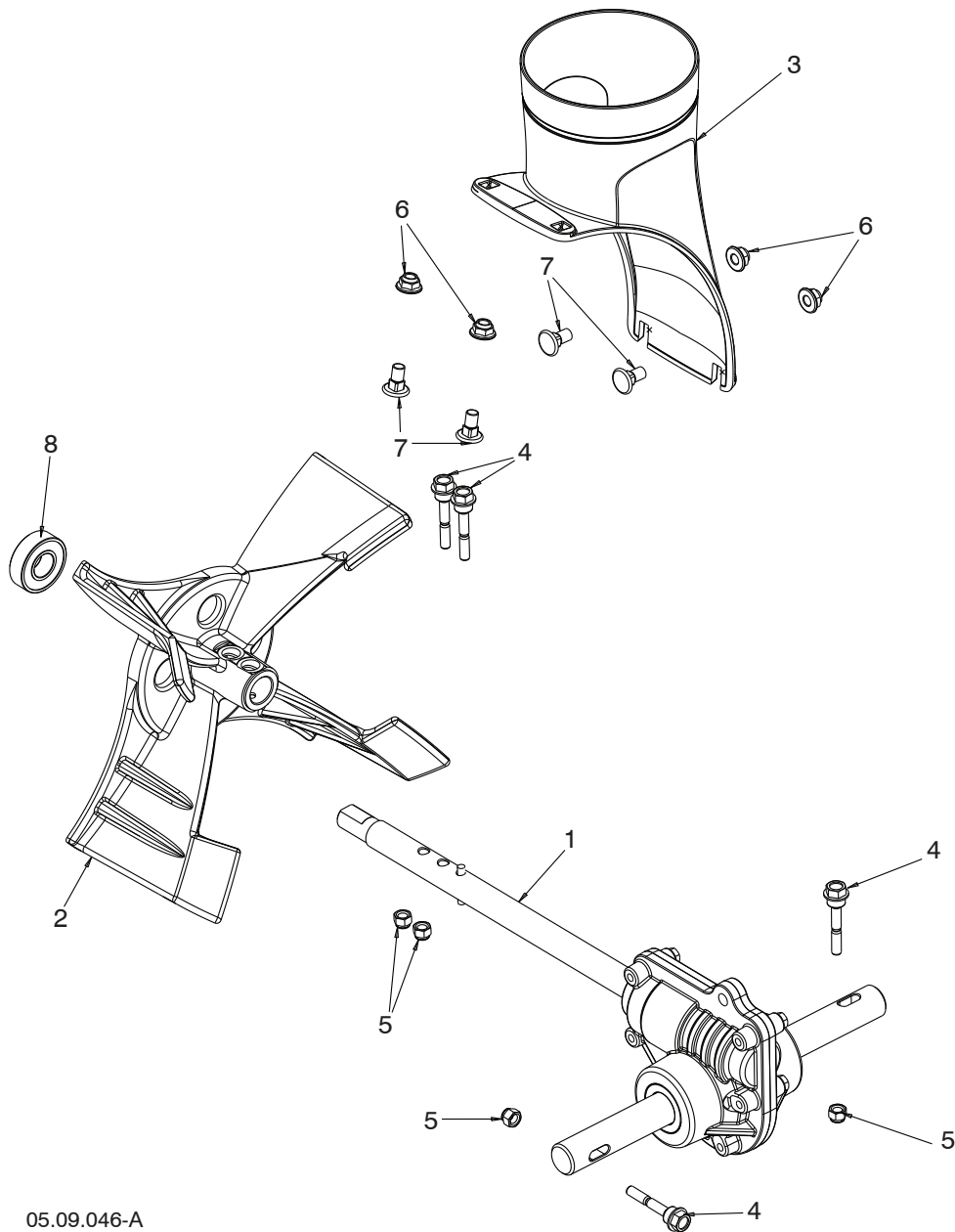

05.09.046-A

KEY NO.	PART NO.	DESCRIPTION	KEY NO.	PART NO.	DESCRIPTION
1	582 86 77-01	AUGER TRANSMISSION, CAST IRON	5	595 08 66-01	NUT. NYLOCK 1/4-20
2	585 19 83-03	IMPELLER, CAST IRON	6	585 69 13-01	NUT. FLANGE. NY LOCK 5/16-18 - BLK
3	593 04 28-02	CHUTE. DISCHARGE. BASE - CAST ALUMINUM	7	585 69 12-01	BOLT. CARRIAGE. WAFER HEAD 5/16-18 X 5/8- BLK
4	588 07 75-02	BOLT. SHEAR 1/4-20	8	532 19 87-91	BEARING. BALL

NOTE: All component dimensions given in U.S. inches. 1 inch = 25.4 mm
IMPORTANT: Use only Original Equipment Manufacturer (O.E.M.) replacement parts. Failure to do so could be hazardous, damage your snow thrower and void your warranty.

REPAIR PARTS

AUGER HOUSING / IMPELLER ASSEMBLY

SNOW THROWER - MODEL NO. ST 430 (96193013101), PRODUCT NO. 961 93 01-31

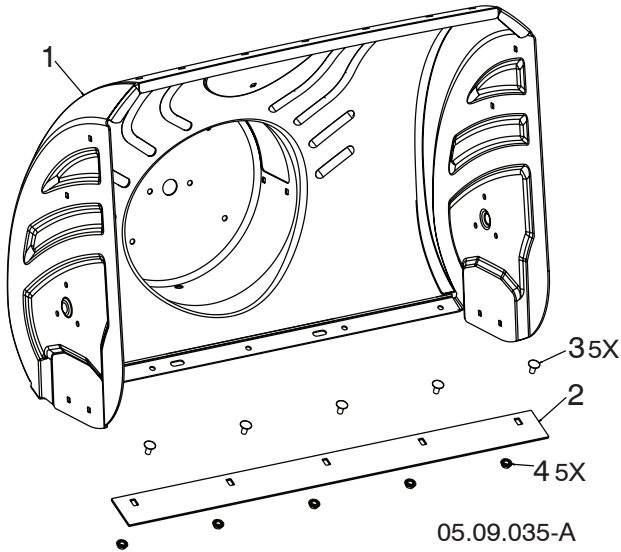

KEY NO.	PART NO.	DESCRIPTION
1	588 61 02-40	AUGER HOUSING 30 LS
2	585 04 85-02	SHAVE PLATE 30 LS MS428
3	596 03 94-01	BOLT CARRIAGE 5/16-18 X .625
4	532 15 53-77	NUT 5/16-18 HEX TOP LOCK

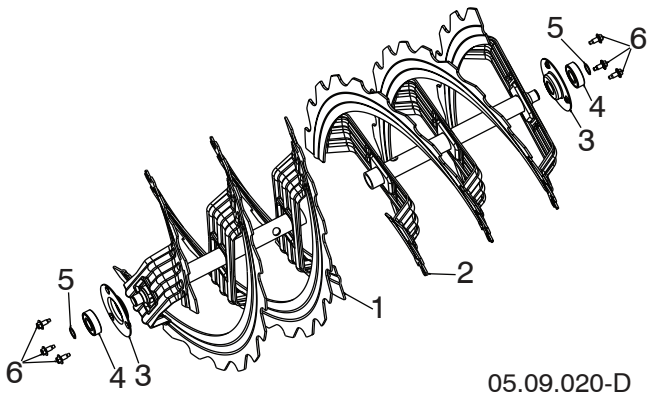

KEY NO.	PART NO.	DESCRIPTION
1	581 97 05-03	AUGER RIBBON 30 RH LS
2	581 97 06-03	AUGER RIBBON 30 LH LS
3	580 85 55-01	SUPPORT AUGER BEARING
4	532 11 04-85	BEARING IDLER 6203
5	812 00 00-28	RING RETAINING #5100-52
6	585 51 78-01	SCREW 1/4-20 X .65 W/DOG POINT

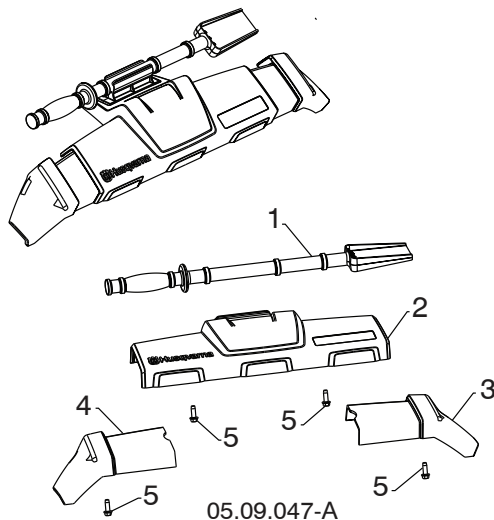

KEY NO.	PART NO.	DESCRIPTION
1	532 19 21-99	TOOL CLEANOUT
2	586 41 48-02	AUGER FRONT TRIM ASM
3	586 33 03-02	TRIM AUGER HOUSING WING RH
4	586 33 04-02	TRIM AUGER HOUSING WING LH
5	817 06 04-10	SCREW HEX WASHER TRI-LOBE 1/4-20 X 3/4

NOTE: All component dimensions given in U.S. inches. 1 inch = 25.4 mm
IMPORTANT: Use only Original Equipment Manufacturer (O.E.M.) replacement parts.
 Failure to do so could be hazardous, damage your snow thrower and void your warranty.

REPAIR PARTS

AUGER HOUSING / IMPELLER ASSEMBLY

SNOW THROWER - MODEL NO. ST 430 (96193013101), PRODUCT NO. 961 93 01-31

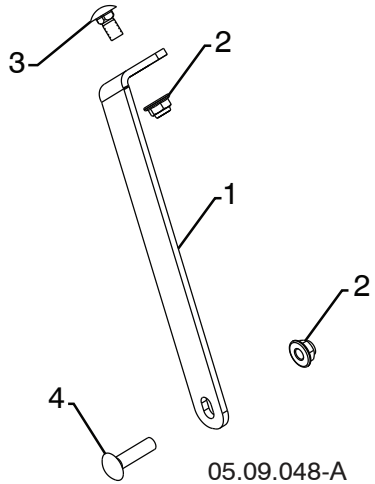

KEY NO.	PART NO.	DESCRIPTION
1	585 10 90-04	SUPPORT GEARBOX LS
2	585 69 13-01	NUT HEX FLG NYLOCK BLK 5/16-18
3	585 83 20-01	BOLT CARRIAGE BLK 5/16-18 X 5/8 BLK
4	872 11 05-10	BOLT CARRIAGE 5/16-18 X 1-1/4

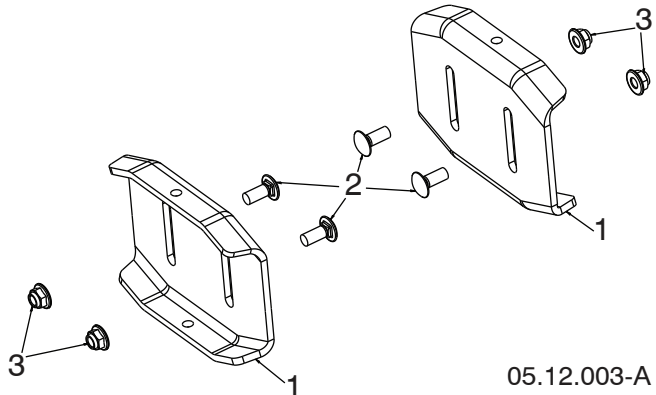

KEY NO.	PART NO.	DESCRIPTION
1	532 40 78-34	SKID PLATE
2	585 69 17-01	BOLT CARRIAGE 5/16-18 X .750 - BLK
3	585 69 13-01	NUT FLANGE NYLOCK 5/16-18 - BLK

NOTE: All component dimensions given in U.S. inches. 1 inch = 25.4 mm
IMPORTANT: Use only Original Equipment Manufacturer (O.E.M.) replacement parts. Failure to do so could be hazardous, damage your snow thrower and void your warranty.

REPAIR PARTS

CONTROL PANEL / DISCHARGE CHUTE

SNOW THROWER - MODEL NO. ST 430 (96193013101), PRODUCT NO. 961 93 01-31

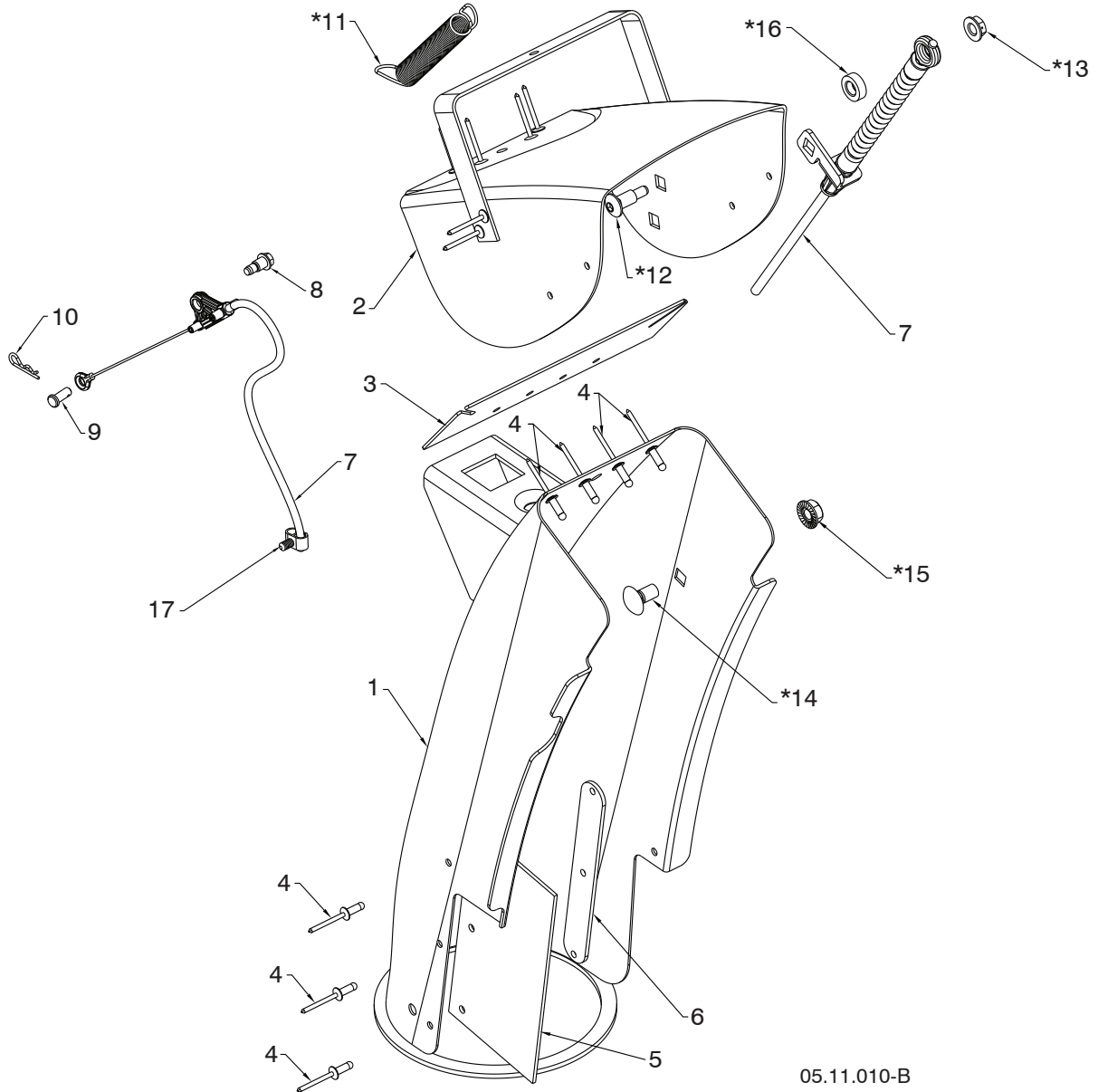

KEY NO.	PART NO.	DESCRIPTION	KEY NO.	PART NO.	DESCRIPTION
1	588 07 78-02	CHUTE WELDMENT	*11	532 18 45-05	DEFLECTOR SPRING
2	-----	RIVETED DEFLECTOR ASSEMBLY	*12	501 41 73-01	CARRIAGE BOLT 1/4-20 X .544
3	-----	DEFLECTOR SEAL	*13	585 69 14-01	NUT 1/4-20
4	-----	POP RIVET	*14	585 83 20-01	CARRIAGE BOLT 3/8-16 X .625
5	-----	CHUTE SNOW SHIELD	*15	873 97 05-00	NUT 5/16-18
6	-----	SHIELD STRAP RETAINER	*16	501 41 74-01	WASHER .362 X .625 X .205 NYLON
7	590 58 70-02	CONTROL.CHUTE. DEFLECTOR.BOWDEN	17	532 18 15-80	CLIP, DUAL
8	590 80 09-01	SHOULDER BOLT 1/4-20	NOTE: ALL ITEMS MARKED WITH AN * ARE PROVIDED IN THE BAG OF ITEMS SHIPPED LOOSE WITH PRODUCT.		
9	581 72 61-01	PIN CLEVIS 1/4 X .438			
10	532 42 33-03	HAIRPIN RETAINER			

NOTE: All component dimensions given in U.S. inches. 1 inch = 25.4 mm
IMPORTANT: Use only Original Equipment Manufacturer (O.E.M.) replacement parts. Failure to do so could be hazardous, damage your snow thrower and void your warranty.

REPAIR PARTS

CONTROL PANEL / DISCHARGE CHUTE

SNOW THROWER - MODEL NO. ST 430 (96193013101), PRODUCT NO. 961 93 01-31

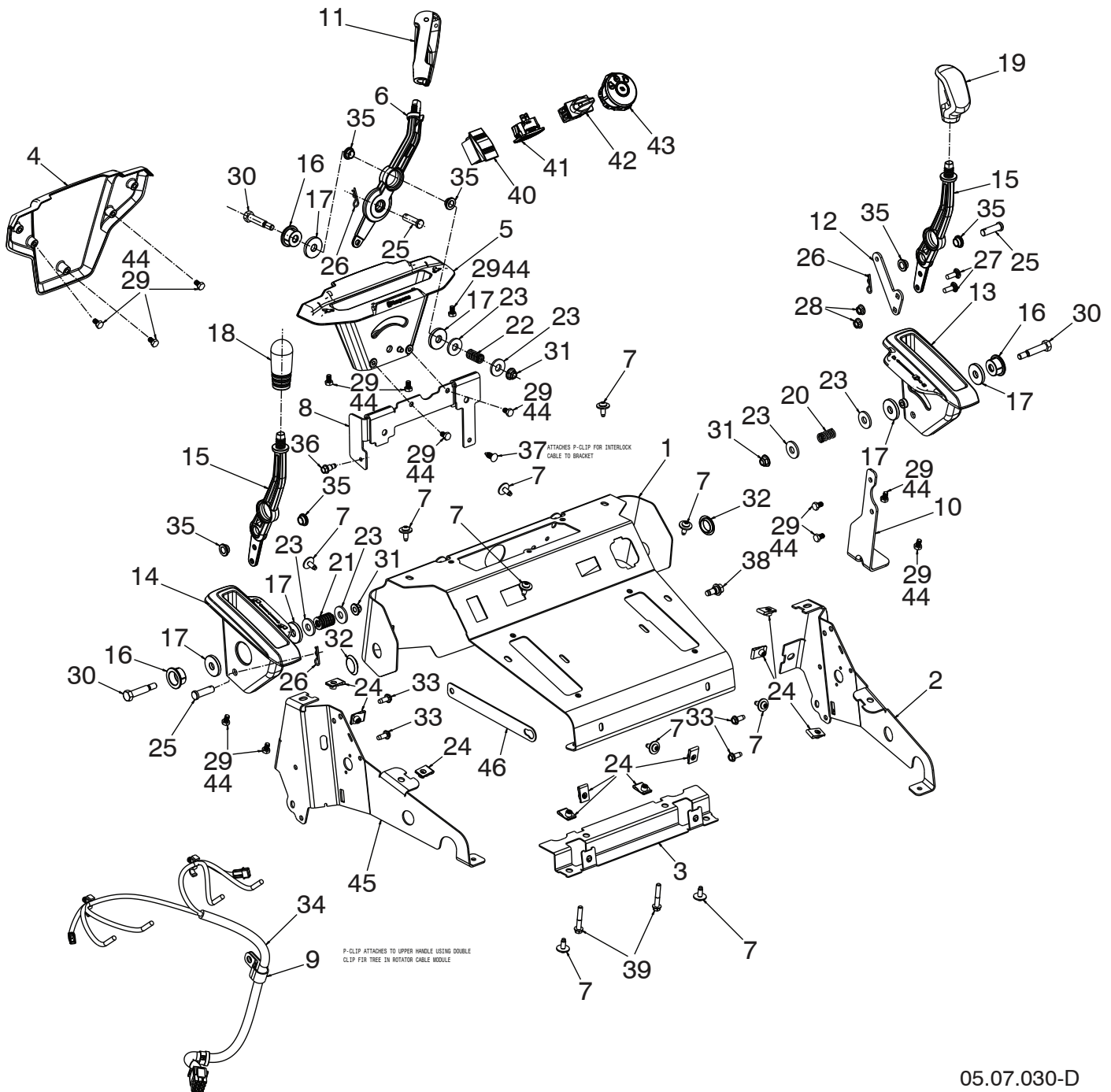

NOTE: All component dimensions given in U.S. inches. 1 inch = 25.4 mm
IMPORTANT: Use only Original Equipment Manufacturer (O.E.M.) replacement parts. Failure to do so could be hazardous, damage your snow thrower and void your warranty.

REPAIR PARTS

CONTROL PANEL / DISCHARGE CHUTE

SNOW THROWER - MODEL NO. **ST 430** (96193013101), PRODUCT NO. 961 93 01-31

KEY NO.	PART NO.	DESCRIPTION	KEY NO.	PART NO.	DESCRIPTION
1	589 62 64-02	CONSOLE BASE	26	532 42 33-03	SPRING HAIRPIN
2	589 62 68-04	CONSOLE SIDE RHS GREY	27	596 23 84-01	1/4-20 X 3/4 CARRIAGE BOLT
3	589 62 69-02	BRACKET REAR CONSOLE	28	532 19 17-30	1/4-20 HEX FLANGE LOCKNUT
4	593 06 84-01	CONSOLE ASSY – LEFT SIDE PANEL	29	597 42 55-01	1/4-20 X 3/8 HEX WASHER HD BOLT
5	589 75 43-01	BRACKET ROTATOR REAR	30	593 09 20-01	BOLT SHOULDER 3/8 X 1.325
6	596 92 41-01	LEVER ROTATOR	31	594 94 44-01	NUT 5/16-18 HEX FLANGE NYLOCK
7	589 77 22-01	SCREW BUTTON HEAD WASHER CAP SCREW	32	593 08 42-01	PLUG 7/8
8	589 79 59-01	BRACKET CABLE CHUTE ROTATOR	33	817 06 04-10	SCREW 1/4-20 x 5/8 HEX WASHER
9	532 19 79-91	P-CLIP	34	593 07 92-01	HARNESS UPPER
10	589 79 65-01	BRACKET HYDRO CABLE	35	590 79 06-01	BUSHING LEVER
11	589 80 11-01	KNOB CHUTE ROTATOR	36	581 72 61-01	BOLT SHOULDER_1_4-20_ TRILOB
12	590 77 47-01	LEVER HYDRO CABLE			
13	589 75 41-01	BRACKET HYDRO LEVER	37	532 42 81-24	FIR TREE
14	589 75 40-01	BRACKET DEFLECTOR LEVER	38	532 17 01-65	BOLT SHOULDER_5-16_18_ THD_FORM
15	589 75 44-01	LEVER HYDRO DEFLECTOR			
16	589 79 61-01	BUTTON BOLT CARRIER	39	501 40 66-01	SCREW
17	589 79 62-01	PAD FRICTION	40	585 80 50-01	SWITCH HEATED GRIP BLACK
18	589 79 63-01	KNOB DEFLECTOR			
19	589 79 64-01	KNOB HYDRO	41	596 51 55-01	HOUR METER
20	589 80 05-01	SPRING HYDRO	42	591 06 65-01	SWITCH - 3 POSITION ROTARY
21	596 91 84-01	SPRING DEFLECTOR	43	594 72 18-01	IGNITION SWITCH - 3 POSITION
22	593 07 51-01	SPRING ROTATOR	44	597 42 57-01	1/4 LOCK WASHER
23	597 36 74-01	WASHER .406 ID 1.00 OD X .109 THK	45	589 62 68-03	CONSOLE SIDE LHS GREY
24	532 41 76-93	1/4-20 CLIP ON NUT	46	597 48 92-02	CHUTE DEFLECTOR SUP PORT BRACE
25	590 79 17-01	PIN CLEVIS .375 X 1.25			

NOTE: All component dimensions given in U.S. inches. 1 inch = 25.4 mm
IMPORTANT: Use only Original Equipment Manufacturer (O.E.M.) replacement parts.
 Failure to do so could be hazardous, damage your snow thrower and void your warranty.

REPAIR PARTS

CONTROL PANEL / DISCHARGE CHUTE

SNOW THROWER - MODEL NO. ST 430 (96193013101), PRODUCT NO. 961 93 01-31

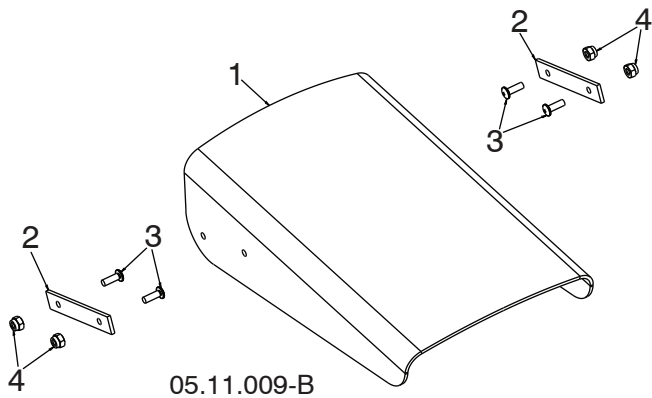

05.11.009-B

KEY NO.	PART NO.	DESCRIPTION
1	532 42 11-38	SHIELD DEFLECTOR
2	532 43 58-31	STRAP
3	586 11 80-01	SCREW MACHINE 8-32 X .50 - BLK
4	586 11 81-01	NUT HEX NYLOCK 8-32 - BLK

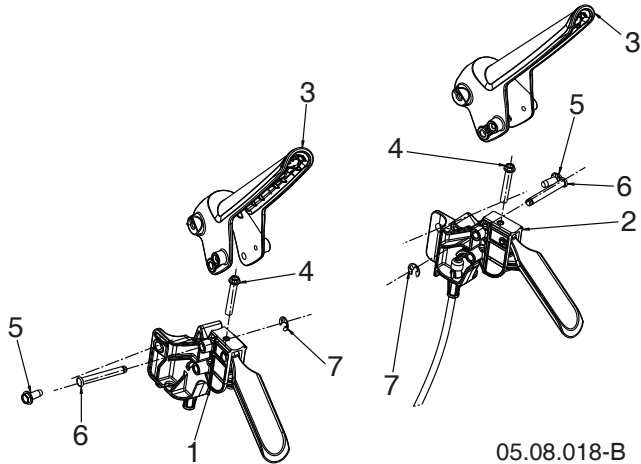

05.08.018-B

KEY NO.	PART NO.	DESCRIPTION
1	589 28 95-03	CABLE, POWER STEER - LHS
2	589 28 95-04	CABLE, POWER STEER - RHS
3	589 80 38-01	LEVER, CONTROL
4	581 32 95-01	SCREW HI-LO 13-16 X 1.50
5	817 06 04-10	SCREW 1/4-20 X .625
6	532 43 17-62	PIN, GROOVED
7	812 00 00-14	E-RING

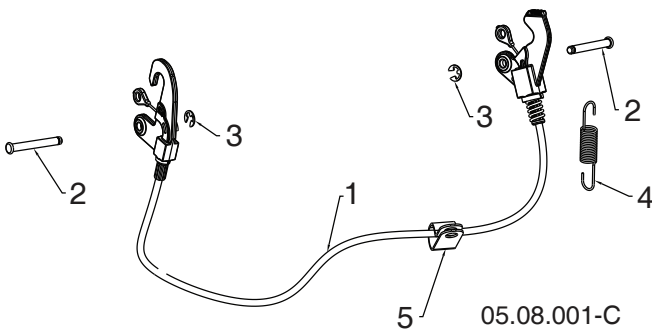

05.08.001-C

KEY NO.	PART NO.	DESCRIPTION
1	593 85 34-01	CABLE INTERLOCK
2	532 43 17-62	PIN GROOVED
3	812 00 00-14	E-RING
4	581 15 12-01	SPRING RETURN
5	532 19 79-91	CLIP CABLE BLACK

NOTE: All component dimensions given in U.S. inches. 1 inch = 25.4 mm
IMPORTANT: Use only Original Equipment Manufacturer (O.E.M.) replacement parts.
 Failure to do so could be hazardous, damage your snow thrower and void your warranty.

REPAIR PARTS

CONTROL PANEL / DISCHARGE CHUTE

SNOW THROWER - MODEL NO. **ST 430** (96193013101), PRODUCT NO. 961 93 01-31

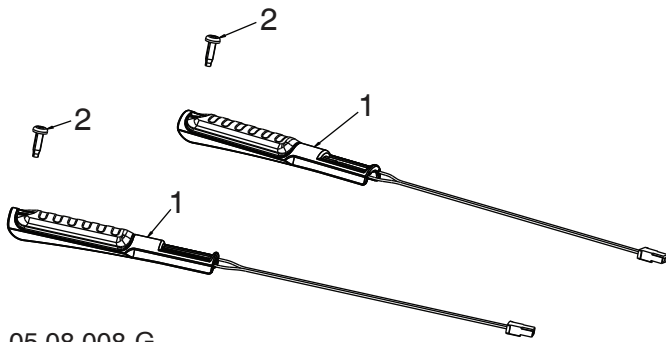

KEY NO.	PART NO.	DESCRIPTION
1	590 49 36-01	GRIP, HEATED, DSST SHO
2	532 44 22-50	SCREW PAN HD TORX 1/4-20 X .75

05.08.008-G

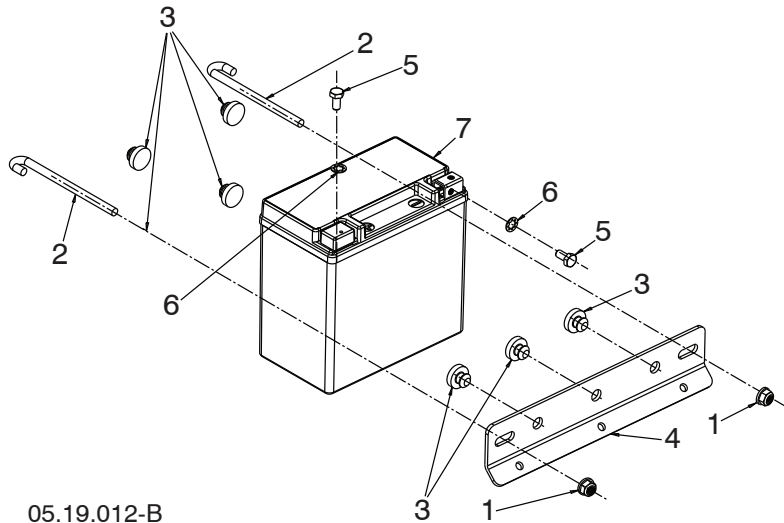

05.19.012-B

KEY NO.	PART NO.	DESCRIPTION
1	582 47 86-02	NUT - 1/4-20 FLANGE LOCKING
2	588 83 94-01	J-HOOK
3	585 98 93-01	BUMPER - RUBBER
4	590 94 29-02	BATTERY STRAP
5	596 32 01-01	SCREW M6X1 X 12L
6	539 99 00-53	INTERNAL STAR LOCK WASHER
7	589 81 95-03	BATTERY AGM 12V 210CCA

NOTE: All component dimensions given in U.S. inches. 1 inch = 25.4 mm
IMPORTANT: Use only Original Equipment Manufacturer (O.E.M.) replacement parts.
 Failure to do so could be hazardous, damage your snow thrower and void your warranty.

REPAIR PARTS

CONTROL PANEL / DISCHARGE CHUTE

SNOW THROWER - MODEL NO. ST 430 (96193013101), PRODUCT NO. 961 93 01-31

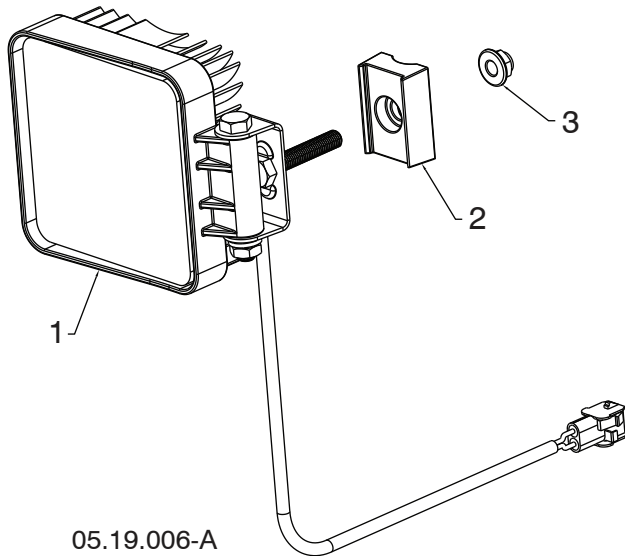

05.19.006-A

KEY NO.	PART NO.	DESCRIPTION
1	590 07 13-01	4.25 X 4.25 LIGHT
2	590 43 98-01	LIGHT MOUNTING BRACKET
3	532 42 79-42	HEX HD 5/16-18 FLANGE NYLOCK

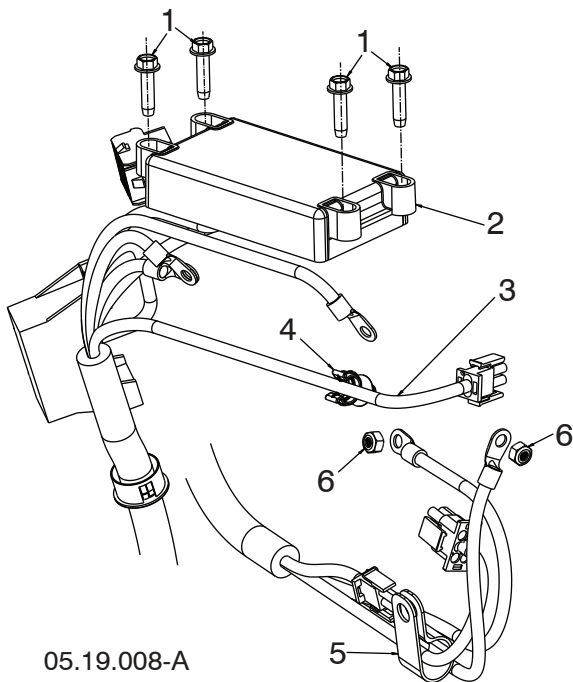

05.19.008-A

KEY NO.	PART NO.	DESCRIPTION
1	585 69 11-01	SCREW 1/4-20 X 1.0
2	593 08 46-01	ENGINE CONTROL UNIT - E-GOV
3	593 20 68-01	HARNESS - LOWER E-GOV
4	595 27 17-01	CLIP, CORRUGATED TUBE
5	532 19 79-91	P CLIP
6	597 43 41-01	M6 X 1.0 NYLOC NUT

NOTE: All component dimensions given in U.S. inches. 1 inch = 25.4 mm
IMPORTANT: Use only Original Equipment Manufacturer (O.E.M.) replacement parts. Failure to do so could be hazardous, damage your snow thrower and void your warranty.

REPAIR PARTS

CONTROL PANEL / DISCHARGE CHUTE

SNOW THROWER - MODEL NO. ST 430 (96193013101), PRODUCT NO. 961 93 01-31

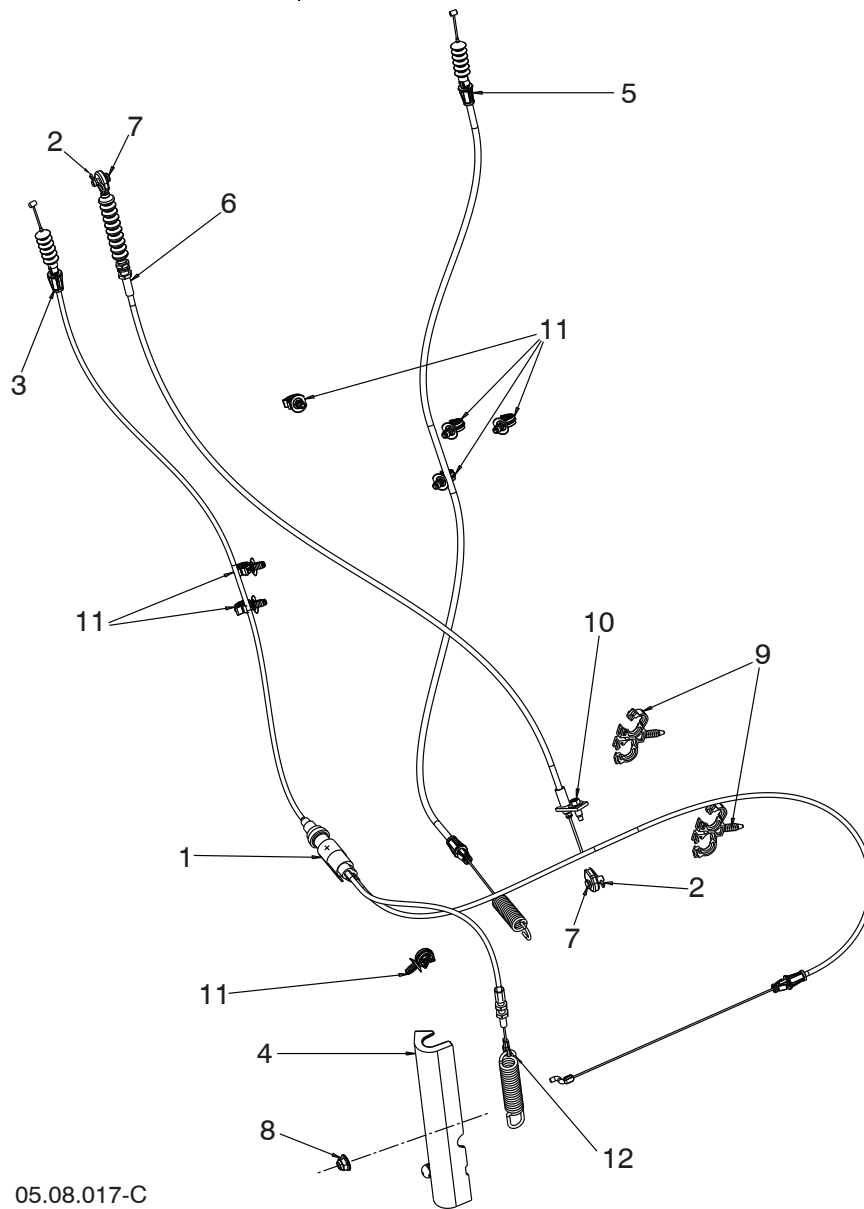

05.08.017-C

KEY NO.	PART NO.	DESCRIPTION	KEY NO.	PART NO.	DESCRIPTION
1	532 19 79-91	CLIP	8	594 94 44-01	NUT
2	532 42 33-03	HAIRPIN	9	584 65 22-01	CLIP, DUAL
3	579 76 36-01	CABLE - IMPELLER	10	585 51 78-01	SCREW - 1/4-20 x .65
4	589 26 52-01	COVER - CABLE	11	592 85 74-01	CLIP, CABLE
5	589 28 98-01	CABLE - HYDRO DRIVE	12	594 71 65-01	AUGER CABLE SPRING
6	590 02 66-01	CABLE - HYDRO SPEED			
7	590 80 09-01	PIN - CLEVIS			

NOTE: All component dimensions given in U.S. inches. 1 inch = 25.4 mm
IMPORTANT: Use only Original Equipment Manufacturer (O.E.M.) replacement parts.
 Failure to do so could be hazardous, damage your snow thrower and void your warranty.

REPAIR PARTS

CONTROL PANEL / DISCHARGE CHUTE

SNOW THROWER - MODEL NO. ST 430 (96193013101), PRODUCT NO. 961 93 01-31

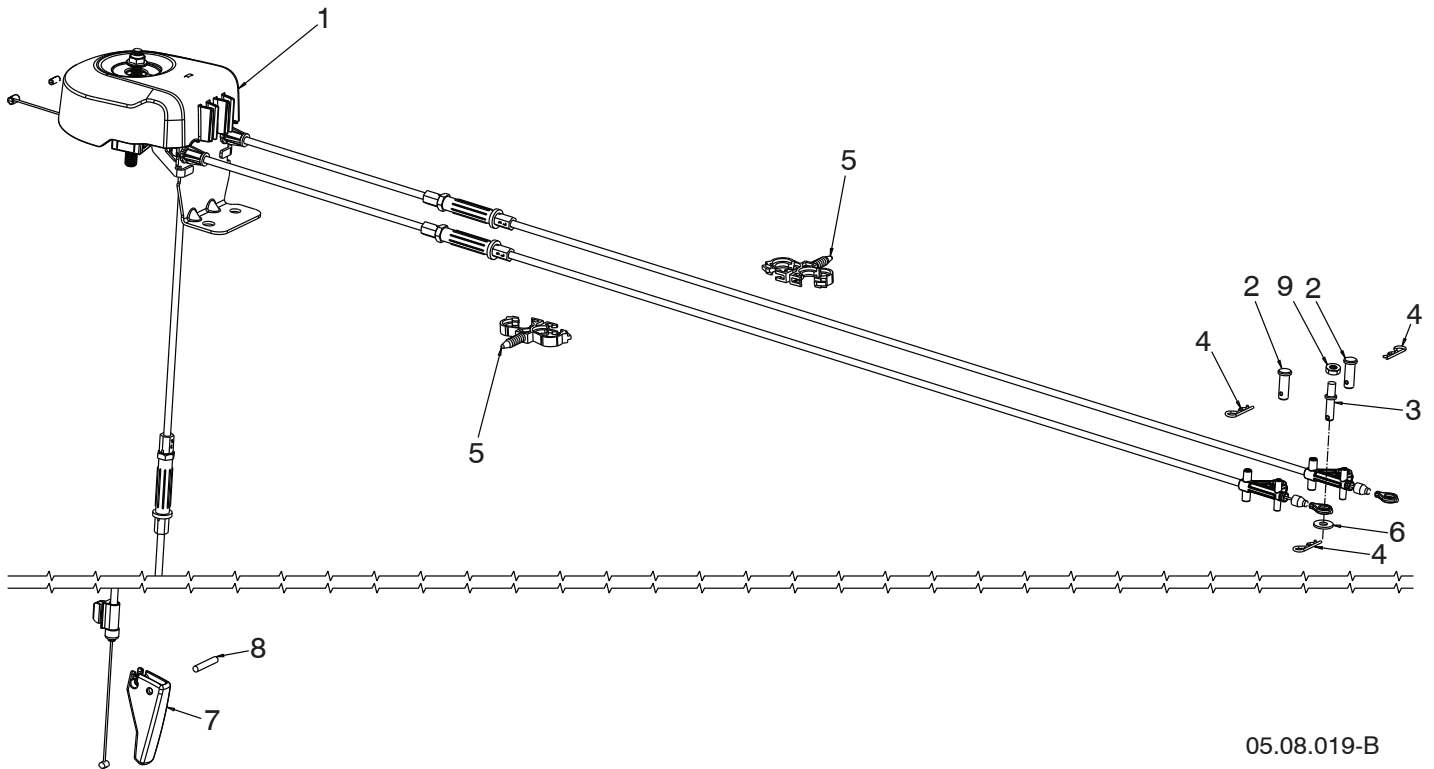

05.08.019-B

KEY NO.	PART NO.	DESCRIPTION
1	591 08 68-02	CABLE CHUTE ROTATOR ASM - LOCKING
2	581 32 94-01	PIN CLEVIS 5/16 X 7/8
3	596 71 72-01	PIN CLEVIS 1/4 X 3/4
4	532 42 33-03	HAIRPIN SOFT ZINC
5	584 65 22-01	CLIP CONDUIT DOUBLE
6	586 68 21-01	WASHER
7	589 79 60-01	ROTATOR LOCK LEVER
8	532 18 42-05	3/16 X 1.0 ROLL PIN
9	595 08 66-01	NUT 1/4-20 HEX NYLOC

NOTE: All component dimensions given in U.S. inches. 1 inch = 25.4 mm
IMPORTANT: Use only Original Equipment Manufacturer (O.E.M.) replacement parts.
 Failure to do so could be hazardous, damage your snow thrower and void your warranty.

REPAIR PARTS

HANDLES

SNOW THROWER - MODEL NO. ST 430 (96193013101), PRODUCT NO. 961 93 01-31

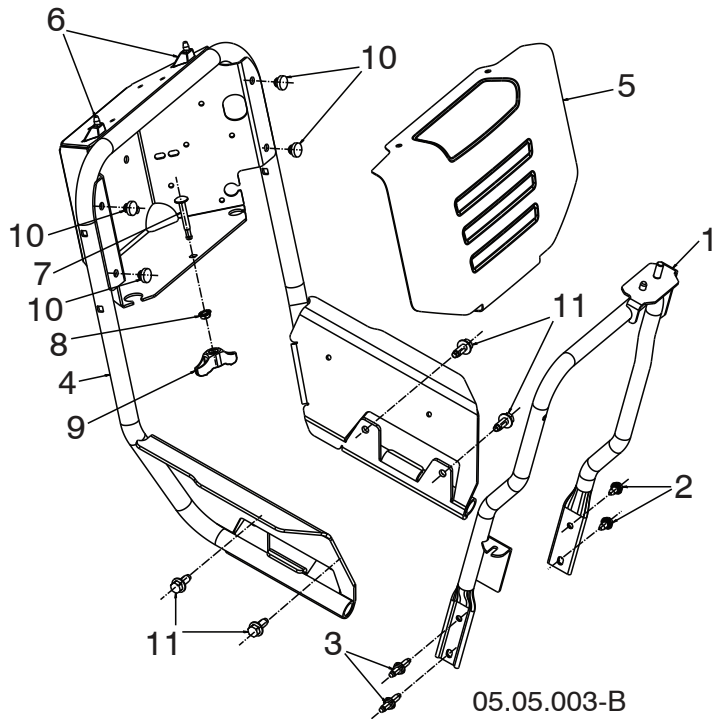

KEY NO.	PART NO.	DESCRIPTION
1	589 26 45-02	SUPPORT
2	817 00 05-10	BOLT 5/16-18 x .625
3	582 91 79-01	STUD - 5/16-18
4	589 87 57-02	HANDLE - LOWER
5	590 94 28-02	COVER - BATTERY
6	595 02 62-01	STUD - BATTERY COVER
7	501 06 71-01	CARRIAGE BOLT 5/16-18
8	532 15 53-77	NUT - 5/16-18
9	594 94 06-01	KNOB
10	585 98 93-01	BUMPER
11	595 51 79-01	SCREW - 3/8-16 MATHREAD

05.05.003-B

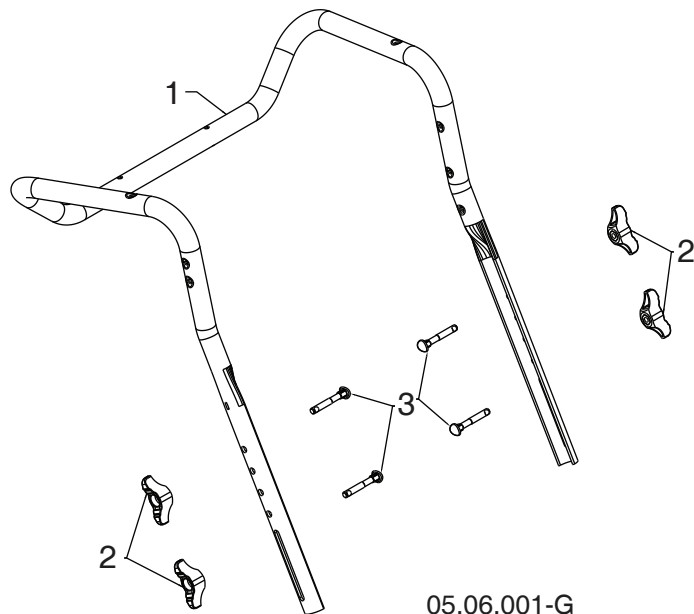

KEY NO.	PART NO.	DESCRIPTION
1	588 16 08-03	UPPER HANDLE
2	532 19 19-38	HANDLE KNOB STD BLACK
3	588 05 99-01	SCREW 5/16-18 X 2.25 CONCAVE HEAD WITH PATCH

05.06.001-G

NOTE: All component dimensions given in U.S. inches. 1 inch = 25.4 mm
IMPORTANT: Use only Original Equipment Manufacturer (O.E.M.) replacement parts.
 Failure to do so could be hazardous, damage your snow thrower and void your warranty.

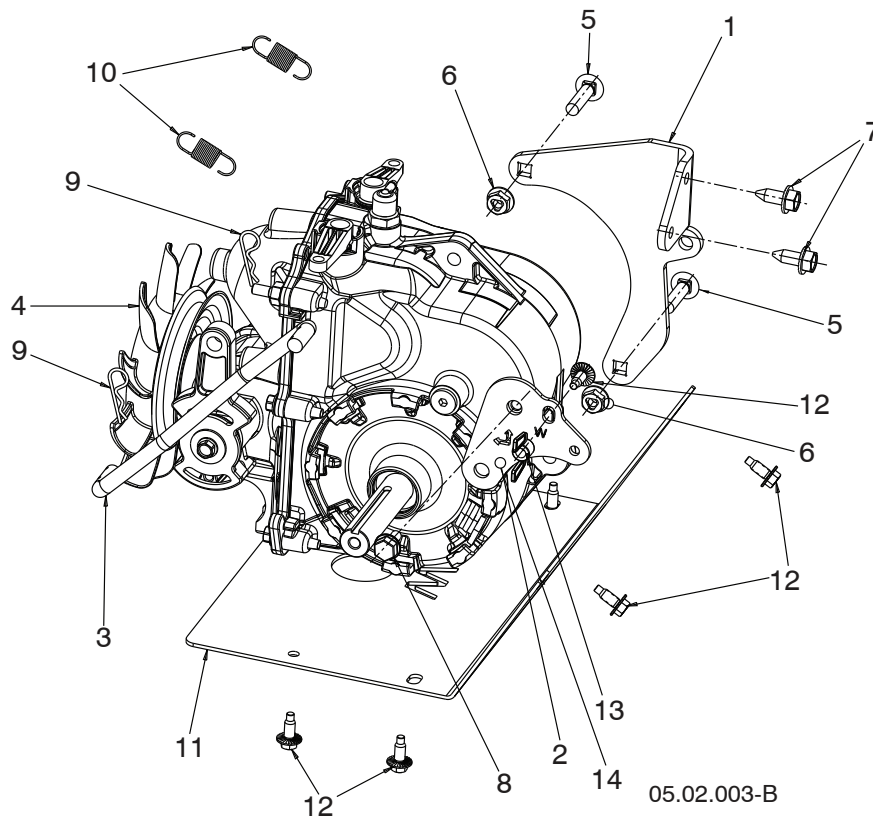

KEY NO.	PART NO.	DESCRIPTION
1	589 28 88-02	TRANSMISSION MOUNT
2	589 28 91-02	SPEED BELCRANK
3	589 28 93-01	SPEED ROD
4	589 28 87-01	TRANSMISSION
5	872 11 05-10	5/16-18 HHCS
6	532 75 11-53	5/16-18 LOCK NUT
7	532 42 88-67	5/16-18 BOLT
8	595 51 76-01	SHOULDER BOLT
9	532 16 96-75	HAIR PIN
10	589 26 37-01	RETURN SPRING
11	583 80 85-02	BELLY PAN WHEEL
12	585 51 78-01	1/4-20 DOG POINT SCREW
13	539 99 09-97	WINGNUT - 1/4-20 NYLOC
14	532 05 38-47	WASHER

NOTE: All component dimensions given in U.S. inches. 1 inch = 25.4 mm
IMPORTANT: Use only Original Equipment Manufacturer (O.E.M.) replacement parts.
 Failure to do so could be hazardous, damage your snow thrower and void your warranty.

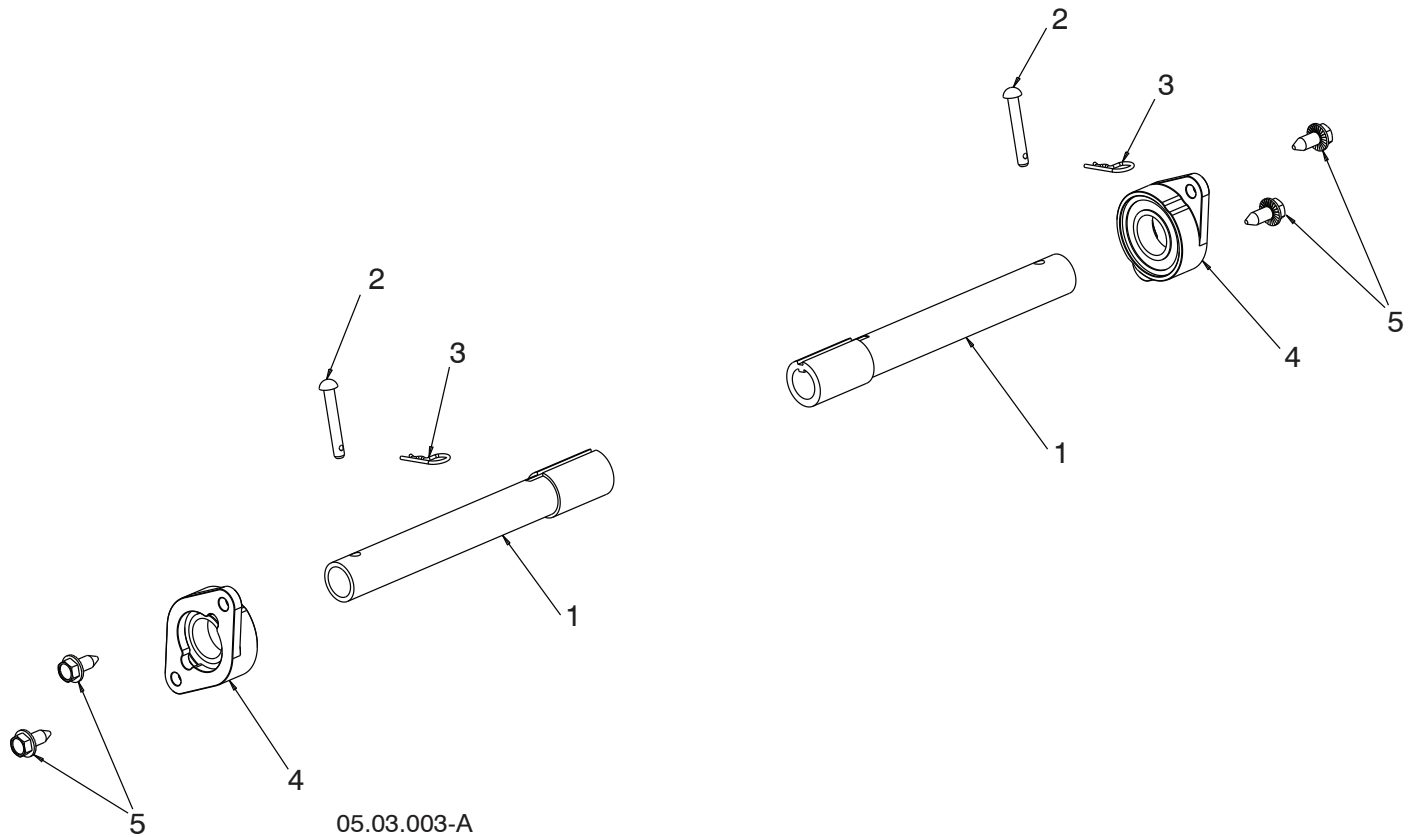

KEY NO.	PART NO.	DESCRIPTION
1	589 28 97-01	AXLE TUBE
2	532 12 68-75	AXLE PIN
3	532 12 47-88	HAIR PIN
4	590 00 06-01	CARRIER WITH BEARING
5	532 42 88-67	5/16-18 SCREW

NOTE: All component dimensions given in U.S. inches. 1 inch = 25.4 mm
IMPORTANT: Use only Original Equipment Manufacturer (O.E.M.) replacement parts. Failure to do so could be hazardous, damage your snow thrower and void your warranty.

REPAIR PARTS

CHASSIS / ENGINE / PULLEYS

SNOW THROWER - MODEL NO. ST 430 (96193013101), PRODUCT NO. 961 93 01-31

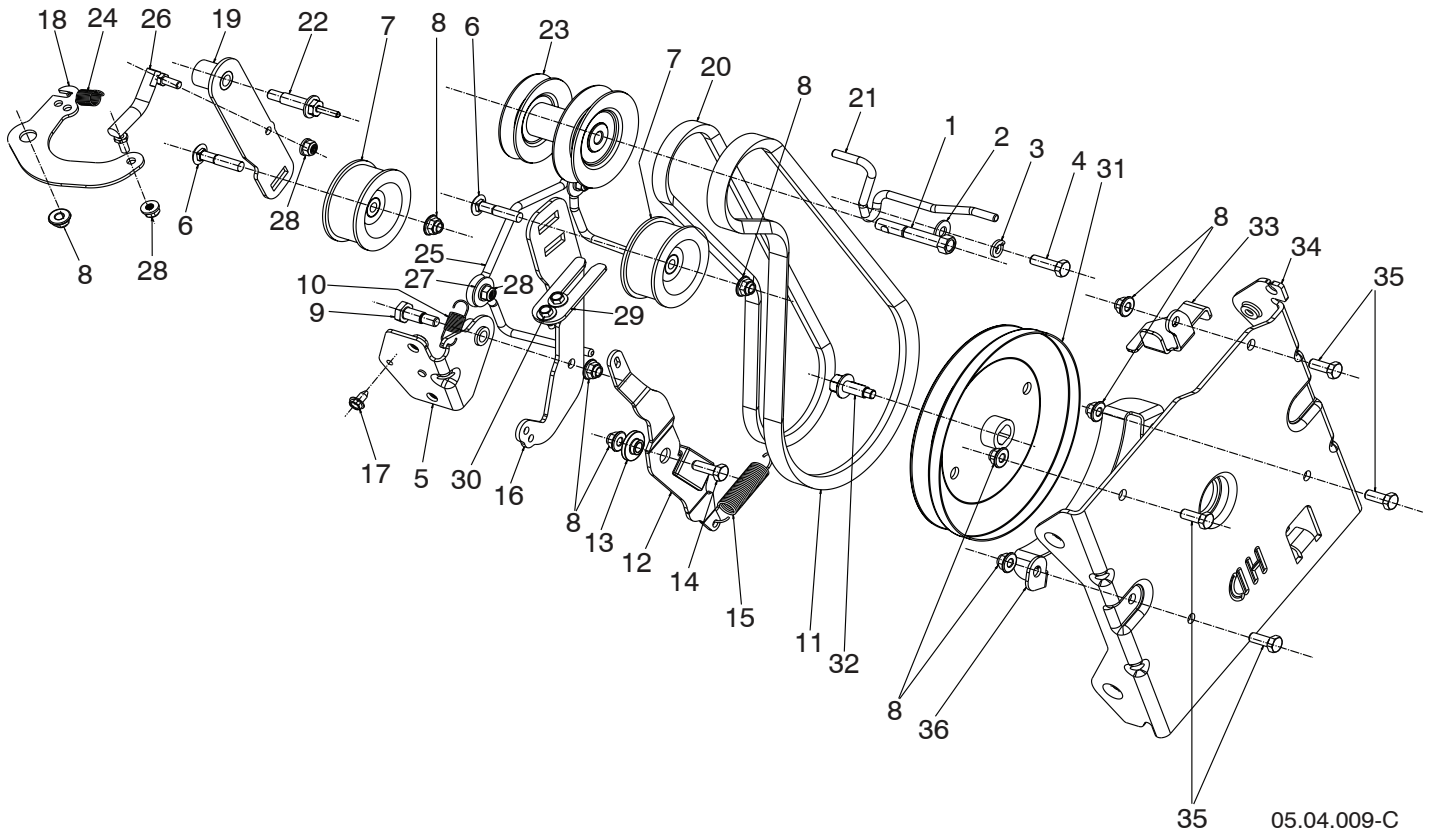

05.04.009-C

KEY NO.	PART NO.	DESCRIPTION	KEY NO.	PART NO.	DESCRIPTION
1	582 38 84-01	BOLT - 3/8-24 X 2.375	20	589 29 06-01	BELT - 4L DRIVE
2	596 20 41-01	WASHER	21	589 29 07-01	GUIDE - BELT 4L DRIVE 5L IMPELLER
3	596 23 88-01	WASHER	22	589 29 08-01	GUIDE - DRIVE BELT
4	874 61 05-16	SCREW - 5/16-24 X 1.0	23	589 26 22-02	PULLEY
5	589 26 34-02	BRACKET - WELDMENT, IDLER ARM	24	589 48 16-01	SPRING
6	589 28 45-01	BOLT - 5/16-18 X 1.50 CARRIAGE	25	589 76 07-01	GUIDE - HYDRO BELT
7	589 26 27-02	PULLEY - IDLER	26	590 72 07-01	LINK ASSY
8	594 94 44-01	FLANGE NUT - 5/16-18	27	513 91 89-00	WASHER
9	589 26 36-01	SCREW - SHOULDER 3/8	28	582 47 86-02	FLANGE LOCKNUT 1/4-20
10	589 26 37-01	SPRING - RETURN	29	592 91 78-02	GUIDE - IDLER ARM
11	589 26 26-02	BELT - 5L HD IMPELLER	30	585 51 78-01	SCREW 1/4-20 X .65 WITH DOG POINT
12	579 76 33-01	ARM	31	589 26 38-01	PULLEY - IMPELLER.DD.5L.HD
13	587 34 37-01	BUSHING	32	595 51 79-01	SCREW - FLANGE HEAD CAP WITH DOG POINT, 3/8-16
14	596 32 22-01	BOLT - 5/16-18 X .875	33	589 26 25-05	GUIDE - BELT 5L
15	579 76 35-01	SPRING - BRAKE	34	501 59 54-02	INTERFACE BRACKET
16	589 26 29-02	ARM - IDLER	35	596 03 05-01	SCREW - 5/16-18 X .75
17	817 06 04-08	SCREW 1/4-20 X .50	36	581 63 20-02	LOWER BELT KEEPER
18	589 28 99-02	BELLCRANK - DRIVE			
19	589 29 05-02	ARM - DRIVE IDLER			

NOTE: All component dimensions given in U.S. inches. 1 inch = 25.4 mm

IMPORTANT: Use only Original Equipment Manufacturer (O.E.M.) replacement parts. Failure to do so could be hazardous, damage your snow thrower and void your warranty.

REPAIR PARTS

CHASSIS / ENGINE / PULLEYS

SNOW THROWER - MODEL NO. ST 430 (96193013101), PRODUCT NO. 961 93 01-31

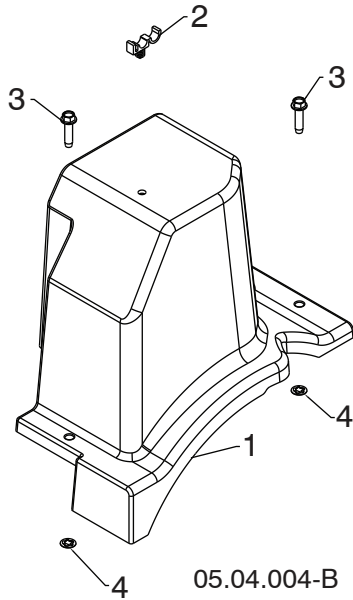

05.04.004-B

KEY NO.	PART NO.	DESCRIPTION
1	587 10 55-01	BELT COVER HI CRANK (INCLUDES ITEM #3 AND #4)
2	532 14 50-06	CABLE GUIDE
3	-----	BOLT HEX WSH THDRL 1/4-20 X 1
4	-----	PALNUT 1/4 IN

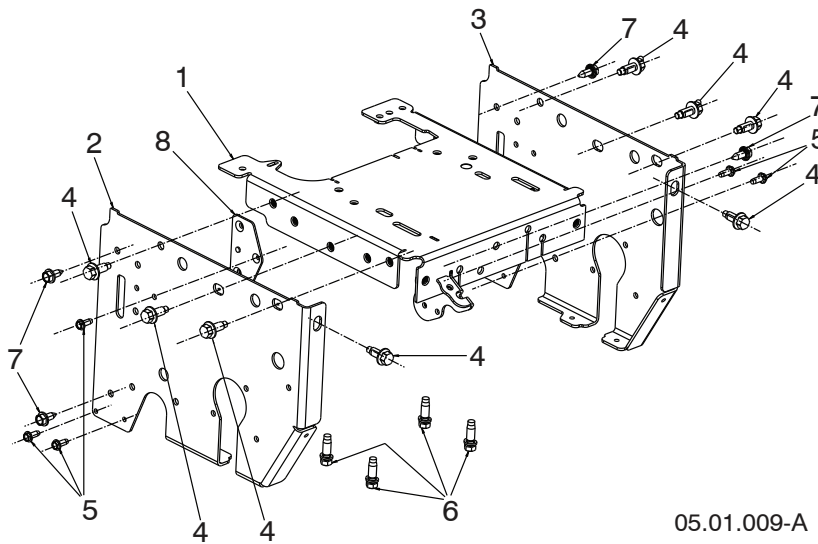

05.01.009-A

KEY NO.	PART NO.	DESCRIPTION
1	583 80 80-02	FRAME TOP
2	583 80 84-03	FRAME SIDE LHS
3	583 80 84-04	FRAME SIDE RHS
4	595 51 79-01	SCREW 3/8-16 X .75 MATHREAD
5	817 06 04-10	SCREW 1/4-20 x .625
6	532 15 04-06	SCREW 3/8-16 x 1.28
7	532 42 88-67	SCREW 5/16-18 x .75
8	590 04 46-02	BRACKET NUT

NOTE: All component dimensions given in U.S. inches. 1 inch = 25.4 mm
IMPORTANT: Use only Original Equipment Manufacturer (O.E.M.) replacement parts. Failure to do so could be hazardous, damage your snow thrower and void your warranty.

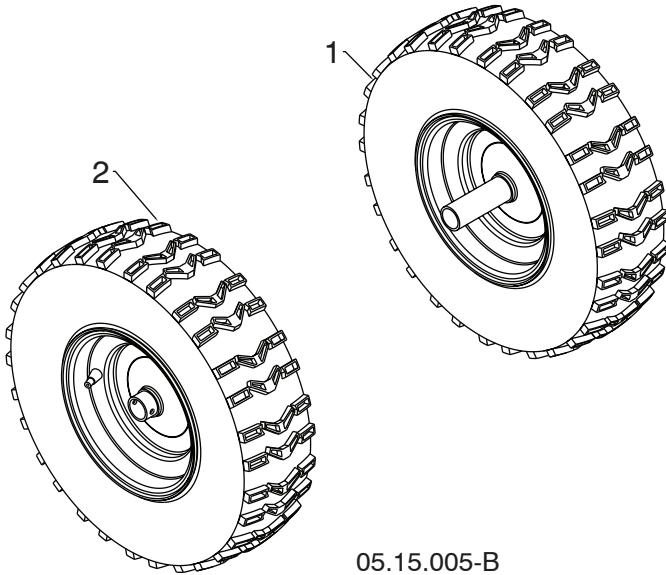

KEY NO.	PART NO.	DESCRIPTION
1	532 43 57-86	WHEEL 16 X 4.80 NPS LH 1.00
2	532 43 57-88	WHEEL 16 X 4.80 NPS RH 1.00

NOTE: All component dimensions given in U.S. inches. 1 inch = 25.4 mm
IMPORTANT: Use only Original Equipment Manufacturer (O.E.M.) replacement parts.
 Failure to do so could be hazardous, damage your snow thrower and void your warranty.

REPAIR PARTS

BAG OF PARTS

SNOW THROWER - MODEL NO. **ST 430** (96193013101), PRODUCT NO. 961 93 01-31

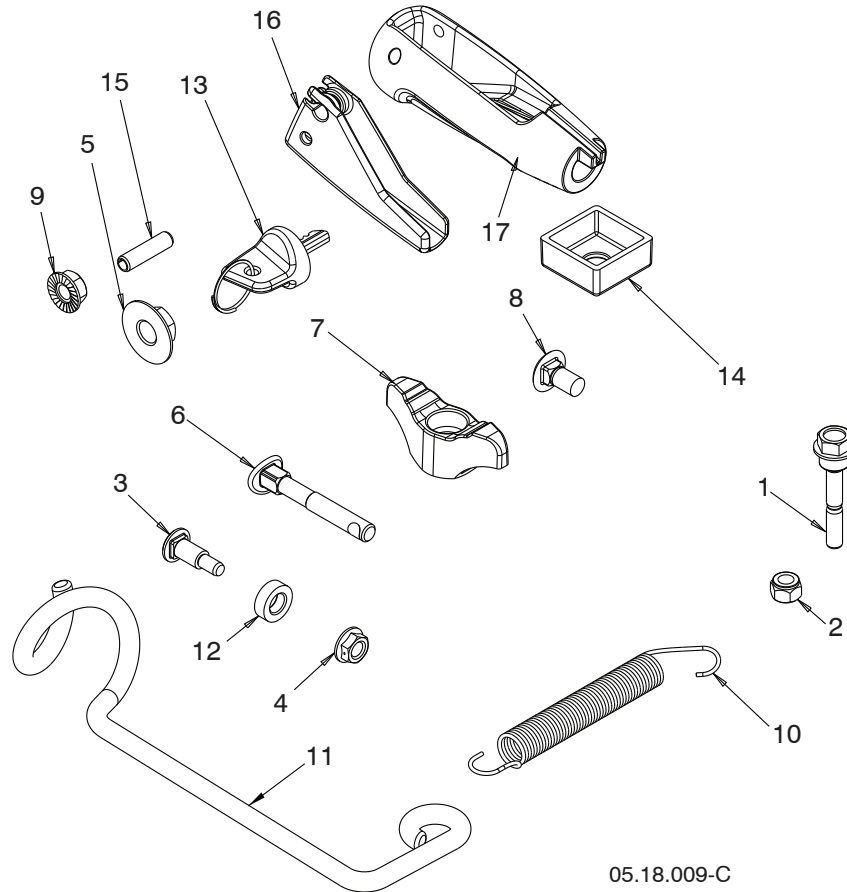

05.18.009-C

KEY NO.	PART NO.	DESCRIPTION	KEY NO.	PART NO.	DESCRIPTION
1	588 07 75-02	BOLT 1/4-20 X 1.81	12	501 41 74-01	WASHER NYLON
2	595 08 66-01	NUT NYLOCK 1/4-20	13	591 07 06-01	IGNITION KEY
3	501 41 73-01	BOLT SHOULDER	14	591 08 74-01	CHUTE RETAINER
4	585 69 14-01	NUT HEX FL 1/4-20 CTR	15	532 18 42-05	ROLL PIN
5	585 69 10-01	NUT NYLOCK 3/8-16	16	589 79 60-01	ROTATOR TRIGGER
6	588 05 99-01	BOLT 5/16-18 X 2.25 CONCAVE	17	589 80 11-01	KNOB CHUTE ROTATOR
7	532 19 19-38	KNOB 5/16-18 TWO-WING	NI	580 94 77-05	BAG PLASTIC 6.5X10.5 WARNING
8	585 83 20-01	BOLT 5/16-18 X .625	NI	581 03 01-35	LABEL, HARDWARE BAG
9	873 97 05-00	NUT SERR FL LOCK 5/16-18	NI	588 07 76-12	KIT REPLACEMENT BAG OF PARTS
10	532 18 45-05	SPRING DEFLECT CHUTE			
11	596 97 68-01	SUPPORT ROTATION CABLE			

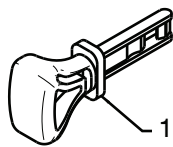

01.14.009-B

KEY NO.	PART NO.	DESCRIPTION
1	532 44 30-59	SAFETY IGNITION KEY KIT

NOTE: All component dimensions given in U.S. inches. 1 inch = 25.4 mm
IMPORTANT: Use only Original Equipment Manufacturer (O.E.M.) replacement parts. Failure to do so could be hazardous, damage your snow thrower and void your warranty.

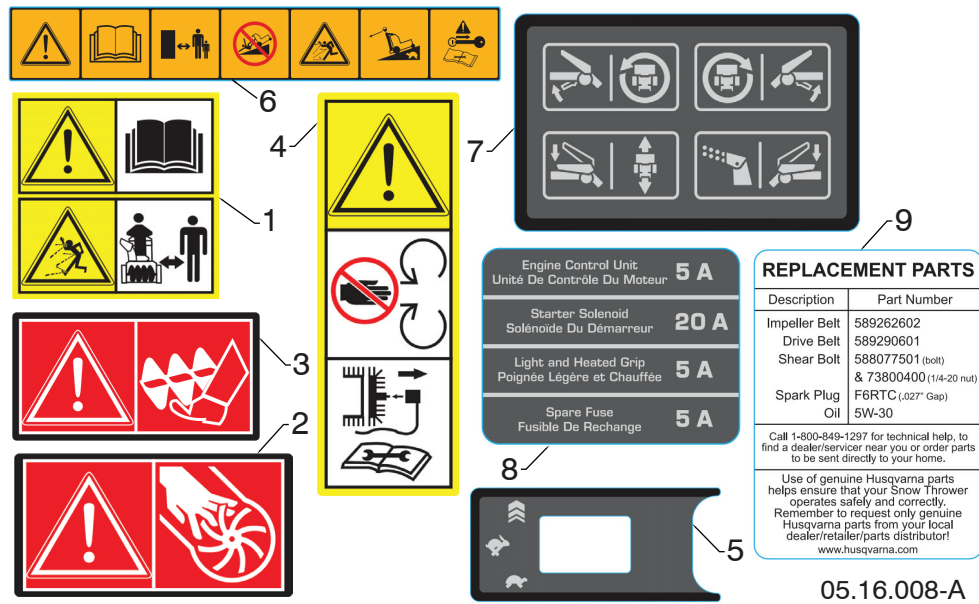

KEY NO.	PART NO.	DESCRIPTION
1	532 18 40-45	DECAL AUGER
2	590 81 22-01	DECAL CHUTE
3	532 19 96-83	DECAL AUGER SAFETY
4	532 18 40-28	DECAL BELT GUARD
5	593 09 25-01	DECAL THROTTLE
6	593 09 26-01	DECAL CONSOLE WARNING
7	593 09 28-01	DECAL CONSOLE INSTRUCTION
8	593 14 69-01	DECAL FUSE
9	593 14 70-01	DECAL REPLACEMENT PARTS

NOTE: All component dimensions given in U.S. inches. 1 inch = 25.4 mm
IMPORTANT: Use only Original Equipment Manufacturer (O.E.M.) replacement parts. Failure to do so could be hazardous, damage your snow thrower and void your warranty.

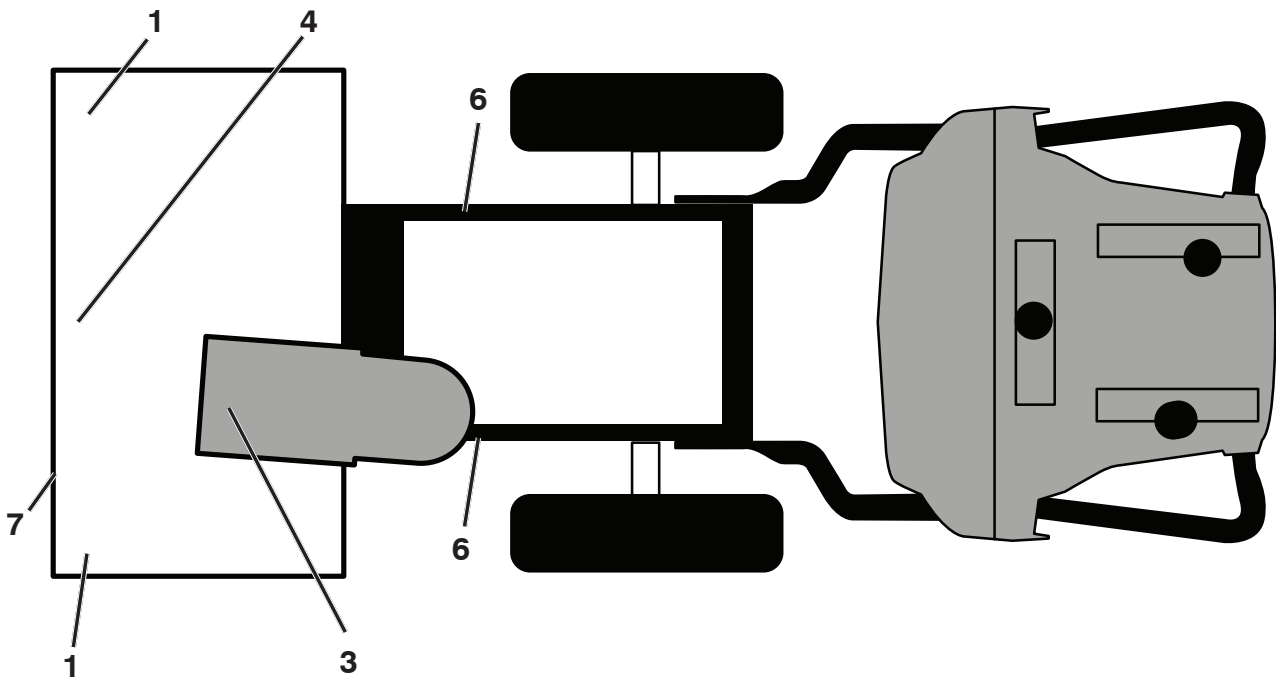

**KEY PART
NO. NO.**

DESCRIPTION

1	532 19 96-83	DECAL, DANGER
3	590 81 22-01	DECAL, DANGER, DEFLECTOR CHUTE
4	532 18 40-45	DECAL, DANGER
6	532 18 40-28	DECAL, BELT GUIDE
7	593 09 63-01	DECAL, AUGER FRONT
--	590 69 72-01	DECAL, ENGINE REWIND (NOT SHOWN)
--	532 42 86-77	"H" EMBLEM (NOT SHOWN)
--	114 07 23-49	OPERATOR'S MANUAL, ENGLISH, FRENCH, SPANISH

NOTE: All component dimensions given in U.S. inches. 1 inch = 25.4 mm

IMPORTANT: Use only Original Equipment Manufacturer (O.E.M.) replacement parts. Failure to do so could be hazardous, damage your snow thrower and void your warranty.

291/306/369/414/420cc E-gov Snow Engines

9999 Options

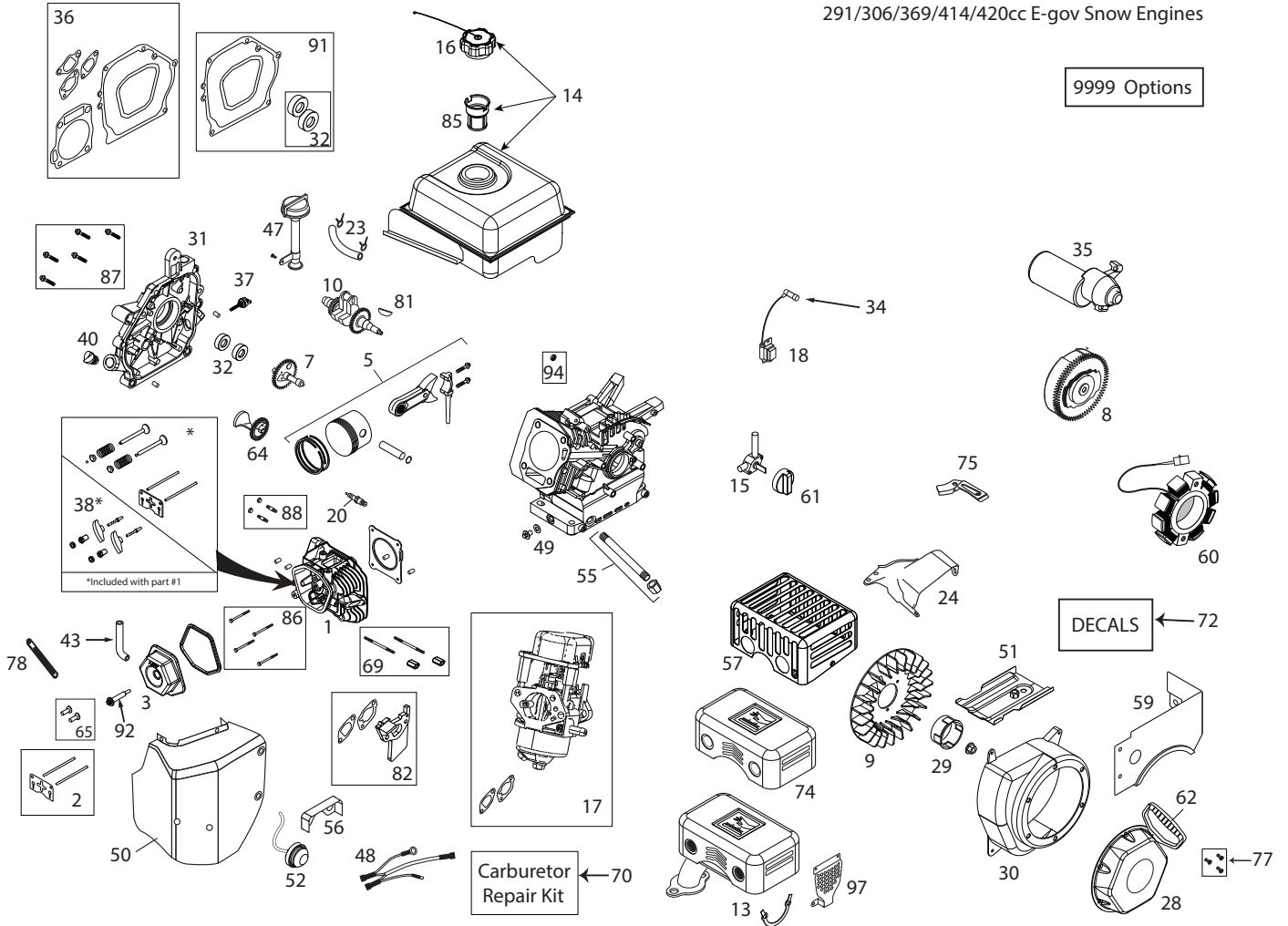

ILLUSTRATION FOR REFERENCE PURPOSES ONLY

ENGINE, LCT

COMPLETE ENGINE-592919101

KEY PART NO.	KEY PART NO.	DESCRIPTION	KEY PART NO.	KEY PART NO.	DESCRIPTION
1	532 42 96-05	CYLINDER HEAD	48	597 38 27-01	WIRE HARNESS (LONG-STEP- PER MOTOR TO ECU
2	532 42 96-06	PUSH ROD & PLATE KIT (INCL. VALVE COVER GSKT)	49	532 43 54-94	OIL DRAIN PLUG W/WASHER
3	532 42 93-03	VALVE COVER (INCL. GASKET)	50	597 41 48-01	CARBURETOR HEATER BOX (W/ LABELS)
5	532 42 93-15	PISTON AND ROD ASSEMBLY	51	532 42 92-31	SHIELD - CYLINDER
7	532 42 93-13	CAMSHAFT	52	532 42 92-18	PRIMER BULB WITH HOSE-SNOW
8	532 44 39-00	FLYWHEEL - ELECTRIC START	55	587 13 99-01	OIL DRAIN TUBE WITH CAP NUT
9	532 42 93-06	COOLING FAN - FLYWHEEL	56	532 42 92-13	CARBURETOR VAPOR SHIELD
10	587 15 13-01	CRANKSHAFT	57	532 43 74-66	CE MUFFLER GUARD
13	587 19 87-01	QUIET MUFFLER	59	582 62 17-01	FUEL TANK SKIRT
14	532 42 92-09	FUEL TANK (3.6L)	60	597 36 03-01	CHARGING COIL (75-WATT AC)
15	532 42 92-34	FUEL TANK ON/OFF VALVE	61	532 43 27-52	FUEL CONTROL KNOB
16	532 42 92-11	FUEL TANK CAP	62	532 44 38-99	STARTER GRIP
17	597 44 67-01	CARB ASSEMBLY (W-STEPPER MOTORS AND GASKETS)	64	532 42 96-08	COUNTER WEIGHT KIT
18	532 44 39-44	IGNITION COIL	65	581 37 29-01	TAPPET KIT (SET OF 2)
20	532 42 49-39	SPARK PLUG	69	586 32 67-01	CARBURETOR MTG STUD KIT (2)
23	532 43 21-46	FUEL HOSE KIT	70	580 35 37-01	CARBURETOR REPAIR KIT
24	597 41 46-01	THROTTLE CONTROL BRACKET (GUARD)	72	587 15 22-01	TWO STAGE SNOW DECAL KIT
28	582 62 15-01	RECOIL STARTER	74	587 37 53-01	MUFFLER HEAT SHIELD
29	582 62 16-01	STARTER CUP	75	532 42 92-32	SHIELD - FLYWHEEL
30	587 39 41-01	BLOWER HOUSING	77	532 43 26-88	RECOIL BOLT KIT (3 BOLTS PER KIT)
31	597 41 47-01	CYLINDER COVER ASSEMBLY	78	585 77 13-01	BREATHER TUBE RETAINING STRAP
32	532 42 93-16	OIL SEAL KIT	81	585 29 72-01	WOODRUFF FLYWHEEL KEYS
34	532 43 69-66	SPARK PLUG BOOT	82	585 02 05-01	CARBURETOR SPACER KIT
35	597 35 92-01	12V ELECTRIC STARTER	85	586 32 56-01	FUEL TANK STRAINER
36	532 42 96-09	ENGINE GASKET KIT	86	586 32 74-01	CYLINDER HEAD BOLT KIT (4)
37	532 43 55-34	SMALL BLACK OIL DIPSTICK (PLASTIC)	87	586 32 70-01	CC COVER BOLT KIT (7)
38	532 42 96-12	ROCKER ARM KIT (INCL. GASKET)	88	586 32 68-01	MUFFLER MTG STUD KIT (2)
40	532 42 92-42	NON-REMOVABLE PLASTIC PLUG	91	587 99 41-04	CRANKSHAFT GASKET KIT
43	587 17 96-01	BREATHER TUBE	92	587 99 52-01	VALVE COVER BOLT (W/ SEAL
47	532 42 92-37	HIGH OIL-FILL TUBE & CAP (NO DIPSTICK)	94	588 48 55-01	GOV SHAFT OIL SEAL
48	597 38 25-01	WIRE HARNESS (TO HAND WAR- MER, LIGHTS&CARB)	97	590 04 66-01	MUFFLER MANIFOLD SHIELD
48	597 38 26-01	WIRE HARNESS (W/ 6 PIN CONNECTOR)	9999	586 32 65-01	HIGH ALTITUDE JET (>6,000 FEET)
			9999	579 80 64-01	BOLT KIT - BLWR HGS/HEATER BOX/TANK SKIRT

