

ILLUSTRATED PARTS LIST

MODEL NUMBER Z448

PRODUCT NUMBER 967 98 46-01

MFG. ID. NUMBER 96798460100

REPAIR PARTS

FRAME ASSEMBLY

ZTR - MODEL NO. Z448 (96798460100), PRODUCT NO. 967 98 46-01

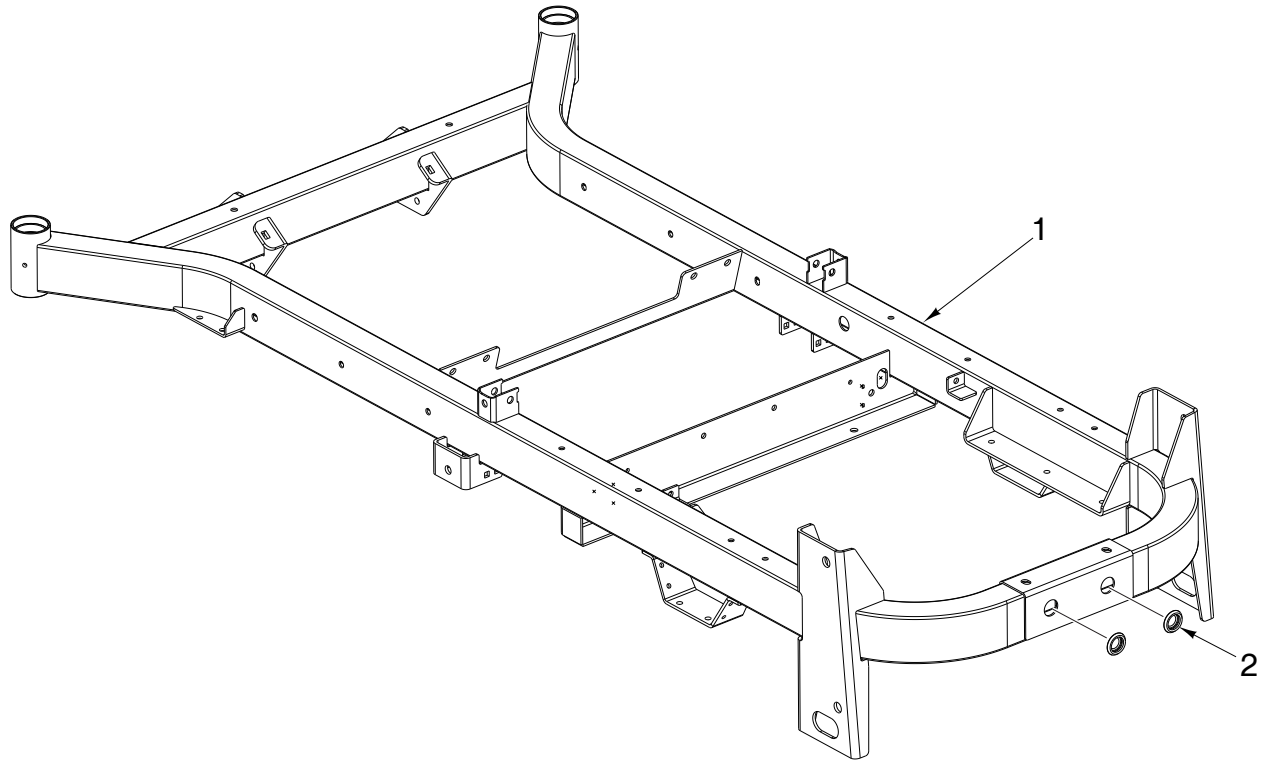

Ref.	Part No.	Description
1	587 39 07-02	KIT FRAME WITH DECALS
2	587 99 05-01	CAP PLUG BP-1 BLACK

NOTE: All component dimensions given in U.S. inches. 1 inch = 25.4 mm
IMPORTANT: Use only Original Equipment Manufacturer (O.E.M.) replacement parts.
Failure to do so could be hazardous, damage your product and void your warranty.

REPAIR PARTS

FRAME ASSEMBLY

ZTR - MODEL NO. Z448 (96798460100), PRODUCT NO. 967 98 46-01

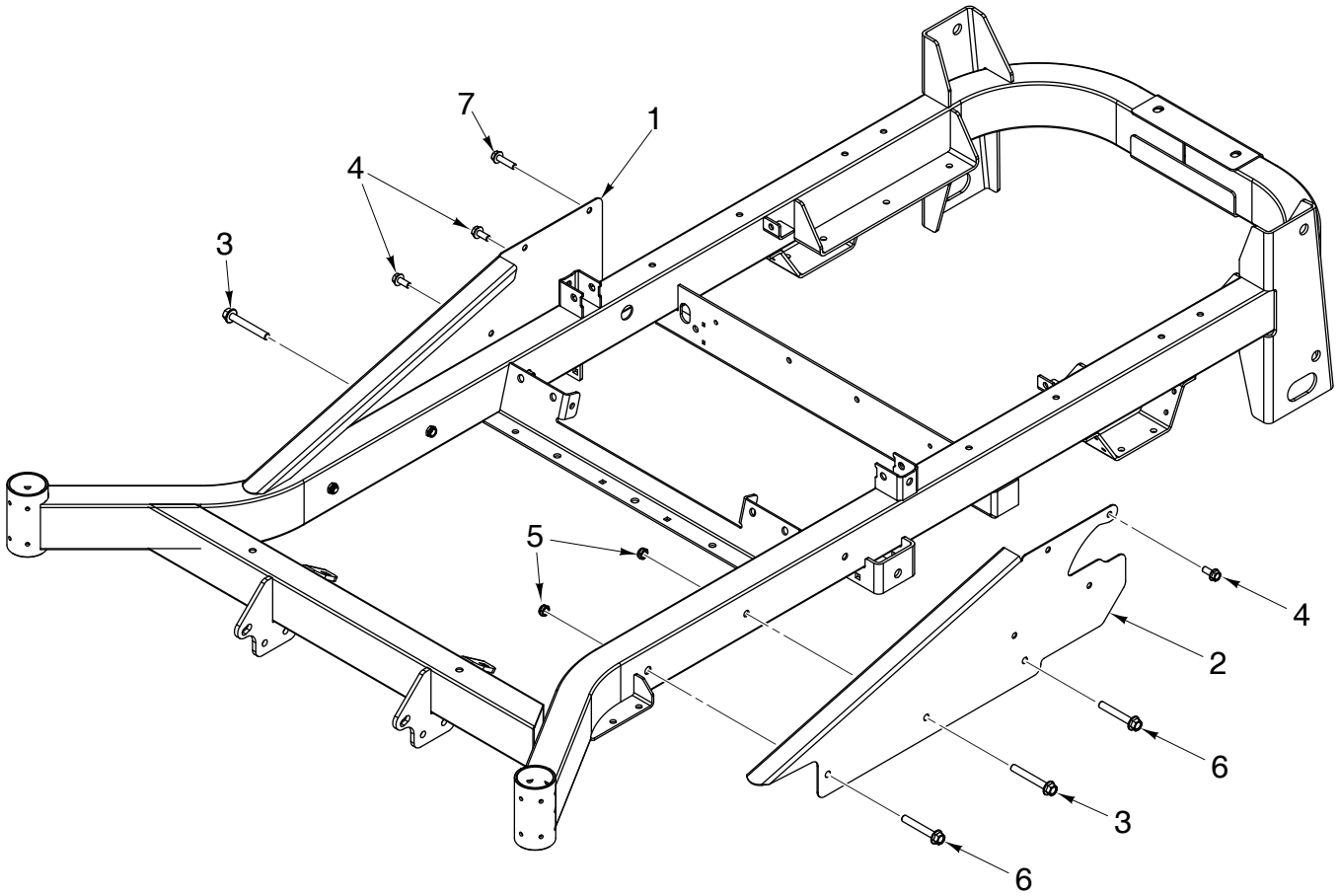

Ref.	Part No.	Description
1	539 13 15-79	SIDE RT ORANGE
2	539 13 15-77	SIDE LT ORANGE
3	596 43 69-01	SCREW HEX 3/8-16 X 2-3/4
4	592 85 87-02	BOLT 5/16-18 X.75 HEX FLANGE
5	596 23 08-01	NUT PREVAIL 3/8-19 X .564
6	596 58 19-01	BOLT HEXAGON 3/8-16 X 2-1/2
7	525 54 40-02	BOLT HEXAGON HEAD 5/16-18X1.25

NOTE: All component dimensions given in U.S. inches. 1 inch = 25.4 mm
IMPORTANT: Use only Original Equipment Manufacturer (O.E.M.) replacement parts.
Failure to do so could be hazardous, damage your product and void your warranty.

REPAIR PARTS

FRAME ASSEMBLY

ZTR - MODEL NO. Z448 (96798460100), PRODUCT NO. 967 98 46-01

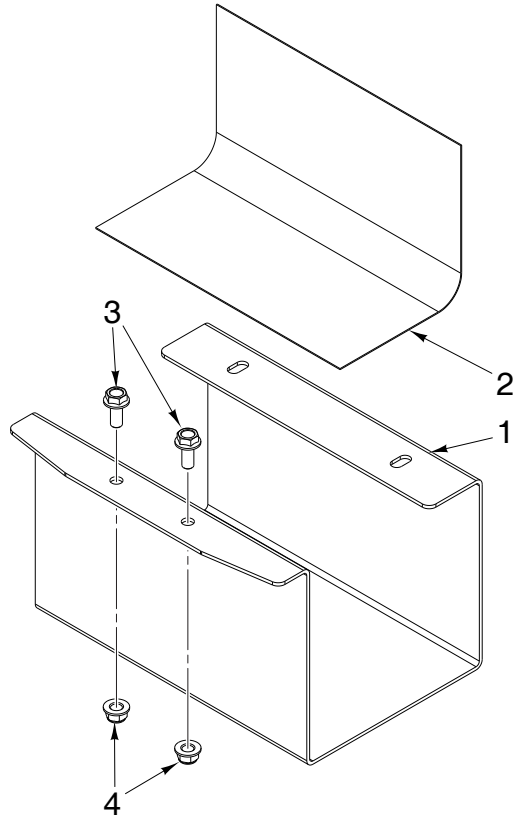

Ref.	Part No.	Description
1	575 23 04-02	SHIELD MUFFLER
2	539 13 28-59	SHIELD, HEAT
3	592 85 87-02	BOLT 5/16-18 X .75
4	594 94 44-01	NUT HEX 5/16-18

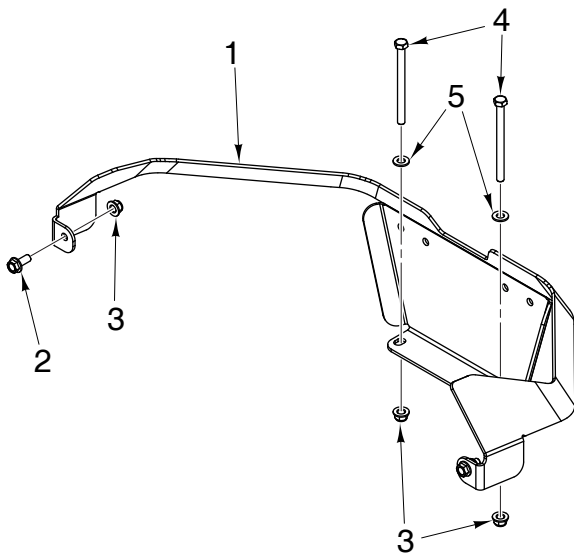

Ref.	Part No.	Description
1	582 69 37-02	GUARD REAR, MZ GRAY X498
2	592 85 87-02	BOLT 5/16-18 X .75 HEX FLANGE
3	594 94 44-01	NUT HEXAGON FLANGE 5/16-18
4	596 43 55-01	BOLT HEX HD 5/16-18UNC X 4"
5	596 20 41-01	WASHER 11/32 X 11/16 X 14

NOTE: All component dimensions given in U.S. inches. 1 inch = 25.4 mm
IMPORTANT: Use only Original Equipment Manufacturer (O.E.M.) replacement parts.
 Failure to do so could be hazardous, damage your product and void your warranty.

REPAIR PARTS

FRAME ASSEMBLY

ZTR - MODEL NO. Z448 (96798460100), PRODUCT NO. 967 98 46-01

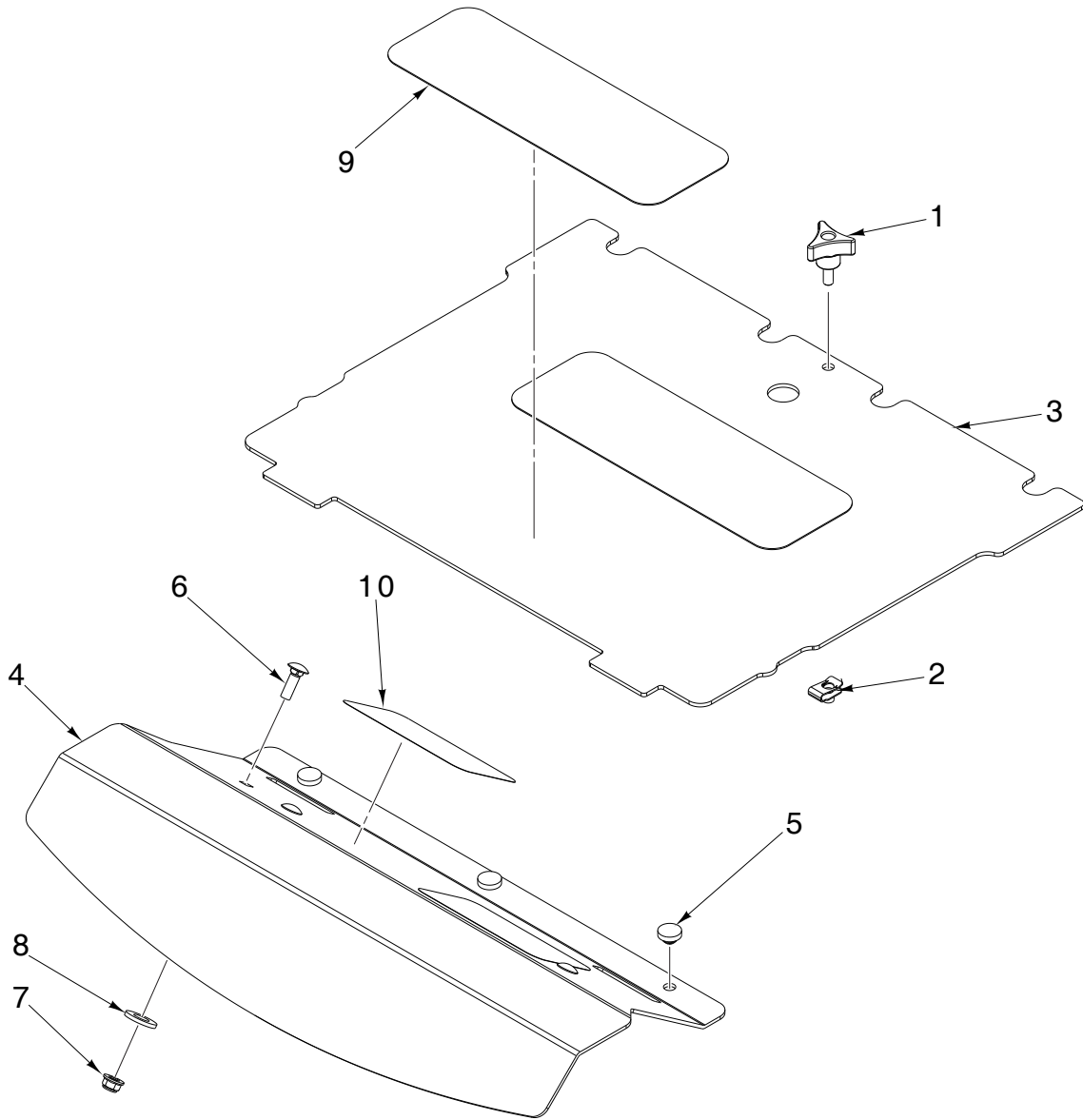

Ref.	Part No.	Description
1	597 78 31-01	KNOB 5/16-18
2	539 10 47-63	NUT 5/16-18
3	539 13 15-81	PLATE FLOOR
4	596 52 22-02	PLATE FOOTREST
5	539 10 25-87	GROMMET, BUMPER
6	595 90 15-01	BOLT CUP 5/16-18 X 1.02
7	594 94 44-01	NUT HEX 5/16-18
8	595 08 68-01	WASHER ROUND .531 X 1.062 X 121
9	539 97 77-78	PAD-ABRASIVE
10	539 12 13-22	FOOT PAD

NOTE: All component dimensions given in U.S. inches. 1 inch = 25.4 mm
IMPORTANT: Use only Original Equipment Manufacturer (O.E.M.) replacement parts.
 Failure to do so could be hazardous, damage your product and void your warranty.

REPAIR PARTS

ENGINE MOUNTING, GUARDS, & MUFFLER

ZTR - MODEL NO. Z448 (96798460100), PRODUCT NO. 967 98 46-01

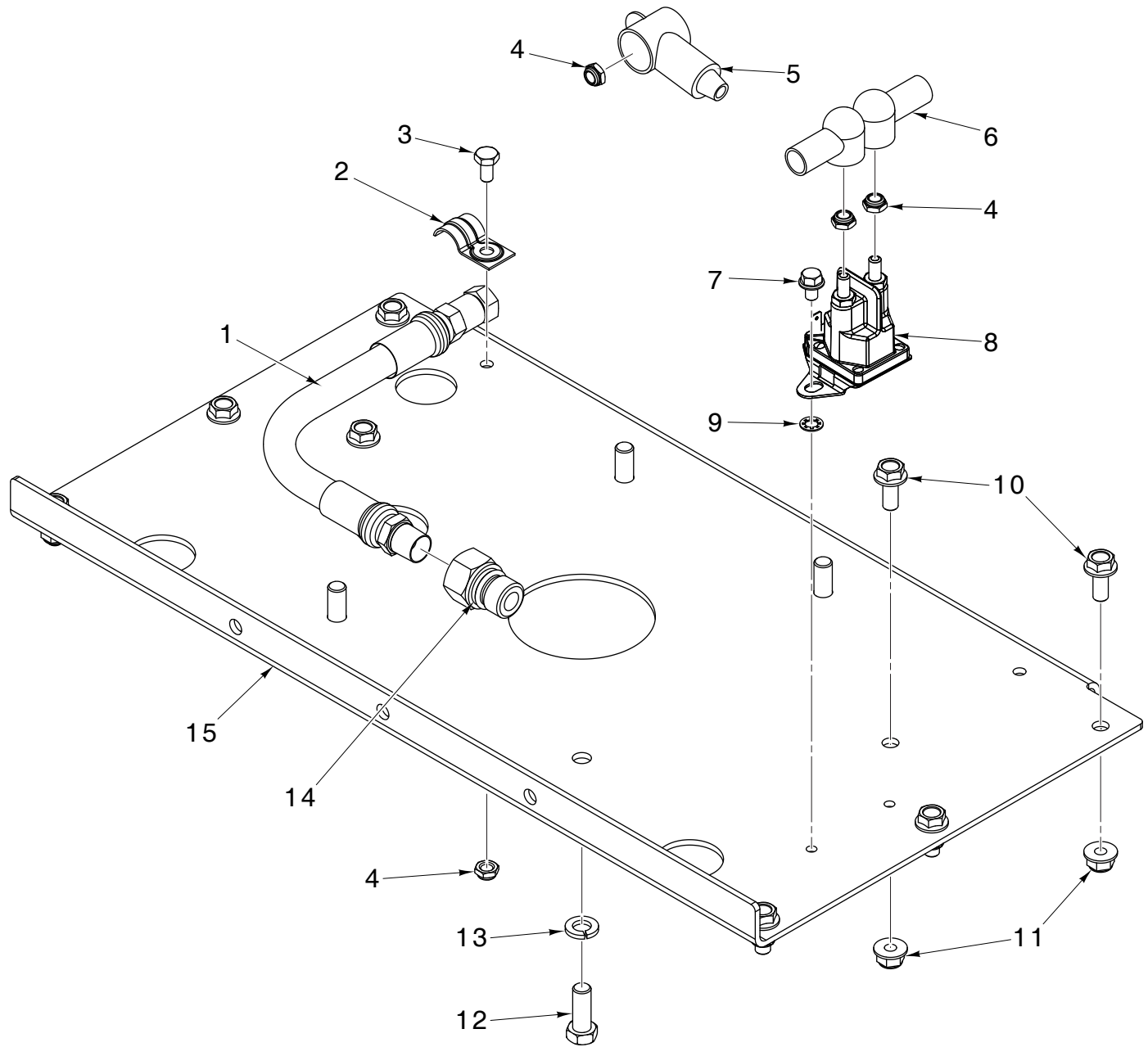

Ref.	Part No.	Description
1	584 82 55-01	HOSE OIL DRAIN
2	539 10 13-63	CLAMP
3	596 43 70-01	HEX HEAD SCREW 1/4-20 X 1/2GR5
4	596 03 15-01	LOCK NUT .188 X .218
5	539 10 27-59	INSULATOR-BATTERY
6	532 13 15-63	COVER TERMINAL RED
7	596 58 27-01	SCREW HEX HEAD
8	582 04 28-02	SOLENOID W/ BRASS PLUNGER

Ref.	Part No.	Description
9	539 99 00-53	WASHER 1/4
10	592 85 87-02	BOLT 5/16-18X .75 HEX
11	594 94 44-01	NUT HEX 5/16-18
12	596 56 44-01	BOLT HEX HEAD 3/8-16 X 1
13	596 23 87-01	WASHER SPRING LOCK
14	522 59 90-02	ADAPTER, OIL DRAIN
15	586 65 14-02	ENGINE PLATE

NOTE: All component dimensions given in U.S. inches. 1 inch = 25.4 mm
IMPORTANT: Use only Original Equipment Manufacturer (O.E.M.) replacement parts. Failure to do so could be hazardous, damage your product and void your warranty.

REPAIR PARTS

ENGINE MOUNTING, GUARDS, & MUFFLER

ZTR - MODEL NO. Z448 (96798460100), PRODUCT NO. 967 98 46-01

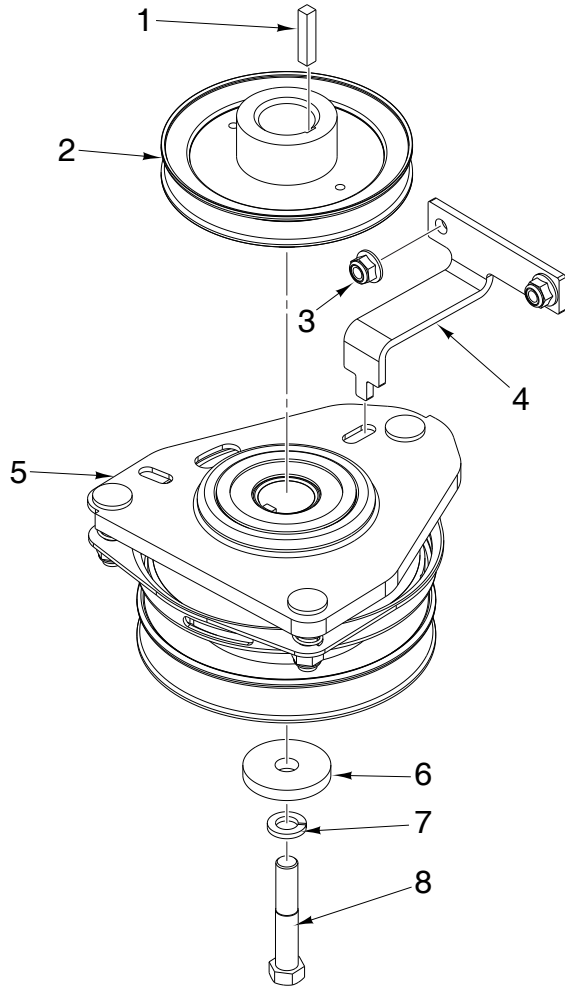

Ref.	Part No.	Description
1	539 91 27-57	KEY SQ 1/4 X 1-1/4
2	585 81 37-01	PULLEY, DRIVE
3	594 94 44-01	NUT HEX 5/16-18
4	585 81 36-02	BRACKET CLUTCH STOP
5	532 17 93-35	CLUTCH
6	596 77 03-01	WASHER 0.469 X 1.75
7	596 23 89-01	WASHER 7/16 IN
8	581 33 28-06	BOLT,CLUTCH 2.5 IN

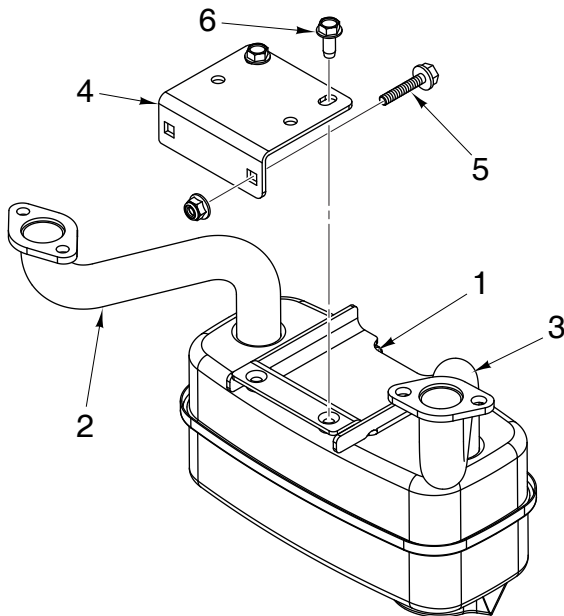

Ref.	Part No.	Description
1	539 13 16-04	MUFFLER ASM TWIN
2	583 95 57-01	TUBE EXHAUST RIGHT
3	583 95 56-01	TUBE EXHAUST LEFT
4	575 22 99-02	BRACKET MUFFLER
5	596 43 57-01	BOLT 5/16-18 X 1.02
6	596 13 59-01	BOLT HEX 5/16-18 X 3/4

NOTE: All component dimensions given in U.S. inches. 1 inch = 25.4 mm
IMPORTANT: Use only Original Equipment Manufacturer (O.E.M.) replacement parts.
 Failure to do so could be hazardous, damage your product and void your warranty.

REPAIR PARTS

STEERING ASSEMBLY

ZTR - MODEL NO. Z448 (96798460100), PRODUCT NO. 967 98 46-01

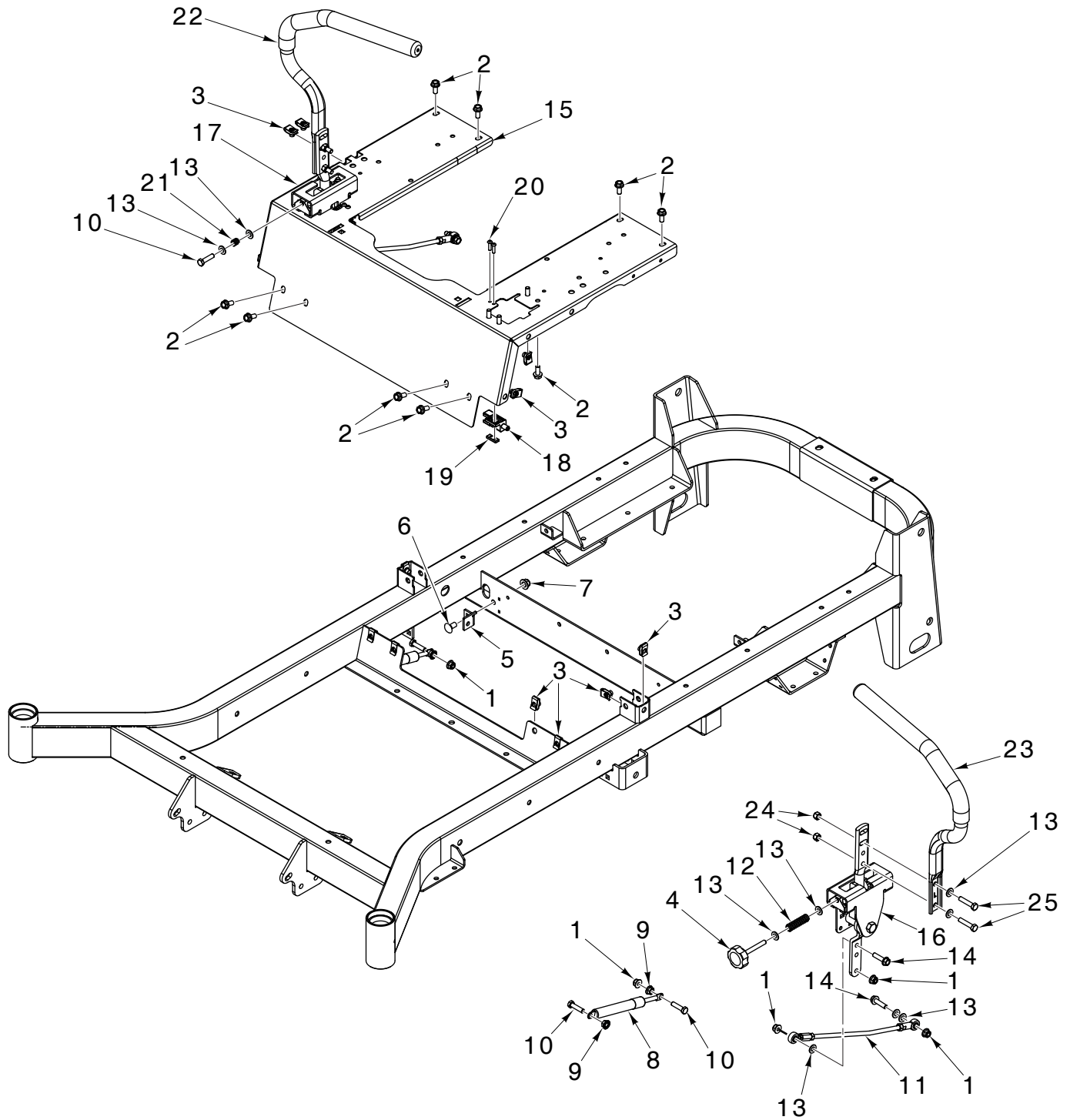

NOTE: All component dimensions given in U.S. inches. 1 inch = 25.4 mm
IMPORTANT: Use only Original Equipment Manufacturer (O.E.M.) replacement parts.
Failure to do so could be hazardous, damage your product and void your warranty.

REPAIR PARTS**STEERING ASSEMBLY****ZTR - MODEL NO. Z448 (96798460100), PRODUCT NO. 967 98 46-01**

Ref.	Part No.	Description
1	594 94 44-01	NUT HEX 5/16-18
2	592 85 87-02	BOLT 5/16-18 X .75 HEX
3	539 10 47-63	NUT 5/16-18 RETAINER
4	596 40 07-01	KNOB 5/16-18 x 2.5
5	575 24 52-02	BRACKET DAMPENER
6	596 13 60-01	BOLT CUP HEAD 3/8-16 X 3/4
7	521 99 65-02	NUT HEX LOCK W/FLANGE 3/8-16
8	539 10 27-20	DAMPENER
9	596 03 92-01	NUT LOCK HEX 5/16-18
10	595 30 57-01	SCREW HEXAGON 5/16-18 X 1-1/4
11	575 25 65-01	ASM, MOTION CONTROL, 3400
12	576 85 03-01	SPRING COMPRESSION
13	596 20 41-01	WASHER 11/32 X 11/16 X 14
14	525 54 40-02	BOLT HEXAGON HEAD 5/16-18X1.25
15	586 86 77-02	SUPPORT SEAT CONTROL
16	587 85 02-02	CONTROL ASSEMBLY LH
17	587 85 02-01	CONTROL ASSEMBLY RH
18	532 10 95-53	SWITCH
19	581 22 30-02	PLATE NUT
20	574 82 27-01	SCREW #10-24 X .75 HD
21	539 10 28-45	SPRING FUEL TANK
22	590 09 08-03	TUBE LEVER CONTROL RT
23	590 09 08-04	TUBE LEVER CONTROL LT
24	596 58 37-02	NUT HEX 5/16-18
25	596 58 22-01	BOLT 5/16-18 X 1-1/2

NOTE: All component dimensions given in U.S. inches. 1 inch = 25.4 mm
IMPORTANT: Use only Original Equipment Manufacturer (O.E.M.) replacement parts.
Failure to do so could be hazardous, damage your product and void your warranty.

REPAIR PARTS

FUEL SYSTEM

ZTR - MODEL NO. Z448 (96798460100), PRODUCT NO. 967 98 46-01

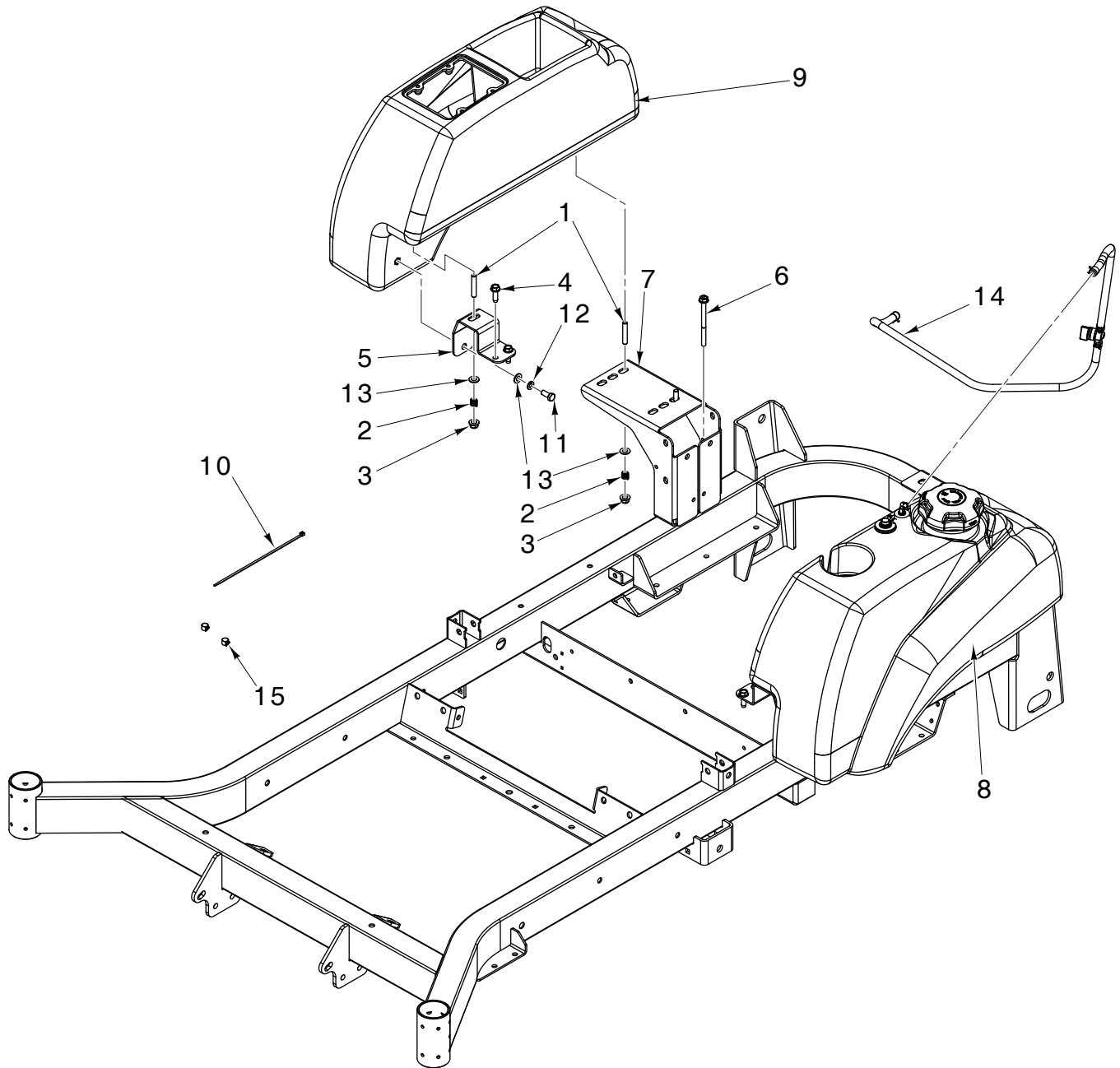

Ref.	Part No.	Description
1	539 10 25-02	TANK-STUD FUEL
2	539 10 28-45	SPRING-FUEL TANK
3	594 94 44-01	NUT HEX 5/16-18
4	596 43 38-01	SCREW HEX 5/16-18 X 1
5	588 84 32-02	SUPPORT TANK FRONT.
6	874 49 05-60	BOLT HEX 5/16-18 X 3.75
7	575 53 36-02	MOUNT TANK
8	585 72 23-05	FUEL TANK ASSY LH

Ref.	Part No.	Description
9	539 10 75-93	FENDER CONSOLE
10	539 97 68-56	TIE-PLASTIC
11	596 03 05-01	BOLT HEX HD 5/16-18 UNC X 3/4
12	596 23 88-01	WASHER LOCK 5/16
13	596 20 41-01	WASHER 11/32 X 11/16 X 14
14	587 04 45-25	HOSE 3/16" VAPOR LINE
15	596 94 15-01	TUBE PURGE FUEL 1.875 IN

NOTE: All component dimensions given in U.S. inches. 1 inch = 25.4 mm
IMPORTANT: Use only Original Equipment Manufacturer (O.E.M.) replacement parts.
 Failure to do so could be hazardous, damage your product and void your warranty.

REPAIR PARTS

IGNITION SYSTEM

ZTR - MODEL NO. Z448 (96798460100), PRODUCT NO. 967 98 46-01

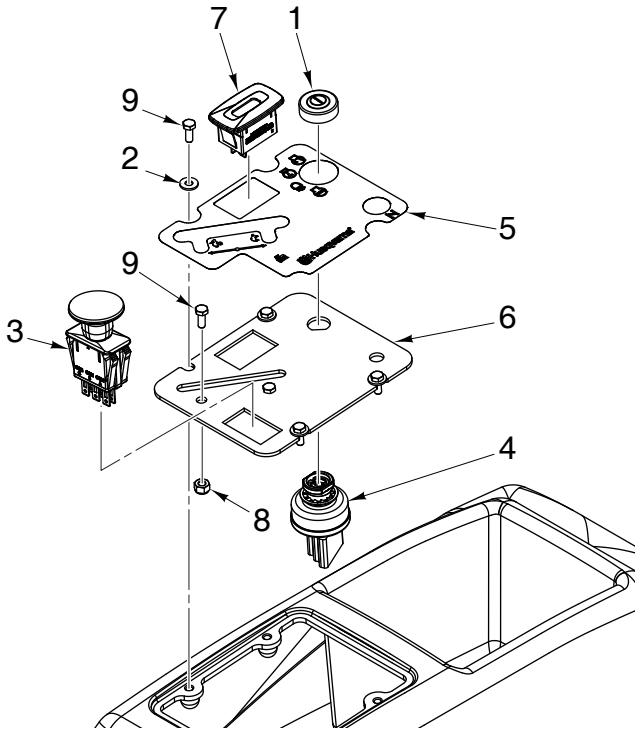

Ref.	Part No.	Description
1	539 10 31-78	NUT CAP IGN SWITCH
2	819 07 08-18	WASHER 7/32 X 1/2 X 18 GA
3	582 10 76-02	SWITCH TERMINAL
4	574 45 54-01	SWITCH, IGNITION
5	574 84 11-03	DECAL, CONSOLE,
6	592 87 74-02	PLATE CONSOLE
7	594 91 91-01	HOURMETER
8	596 04 08-01	LOCK NUT WASHER #10-24 IN
9	596 58 28-01	SCREW HEXAGON #10 X 1/4

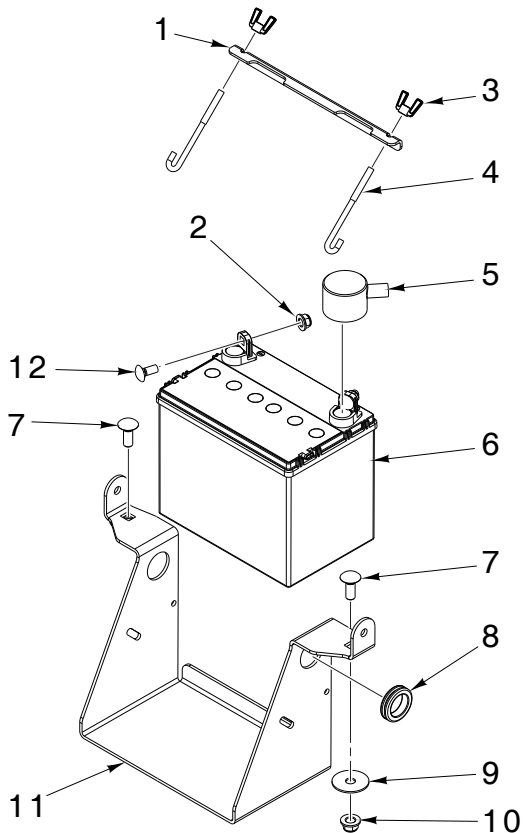

Ref.	Part No.	Description
1	593 63 44-04	BRACKET BATTERY MOUNT
2	594 94 44-01	NUT HEX 5/16-18
3	539 99 09-97	NUT 1/4-20 WINGNUT NYLOC ZD
4	510 06 40-02	HOOK "J"
5	435395	COVER TERMINAL BATTERY
6	539 10 24-63	BATTERY - WET
7	595 31 68-01	BOLT CUP HEAD 3/8-16 X 1
8	539 10 59-74	GROMMET-RUBBER
9	596 13 33-01	WASHER 13/32 X 1-1/2 X 16GA
10	521 99 65-02	NUT HEX LOCK W/FLANGE 3/8-16
11	594 03 74-02	BRACKET BATTERY
12	595 90 16-01	BOLT CUP 5/16-18 X 3/4

NOTE: All component dimensions given in U.S. inches. 1 inch = 25.4 mm
IMPORTANT: Use only Original Equipment Manufacturer (O.E.M.) replacement parts.
 Failure to do so could be hazardous, damage your product and void your warranty.

REPAIR PARTS

BRAKE ASSEMBLY

ZTR - MODEL NO. Z448 (96798460100), PRODUCT NO. 967 98 46-01

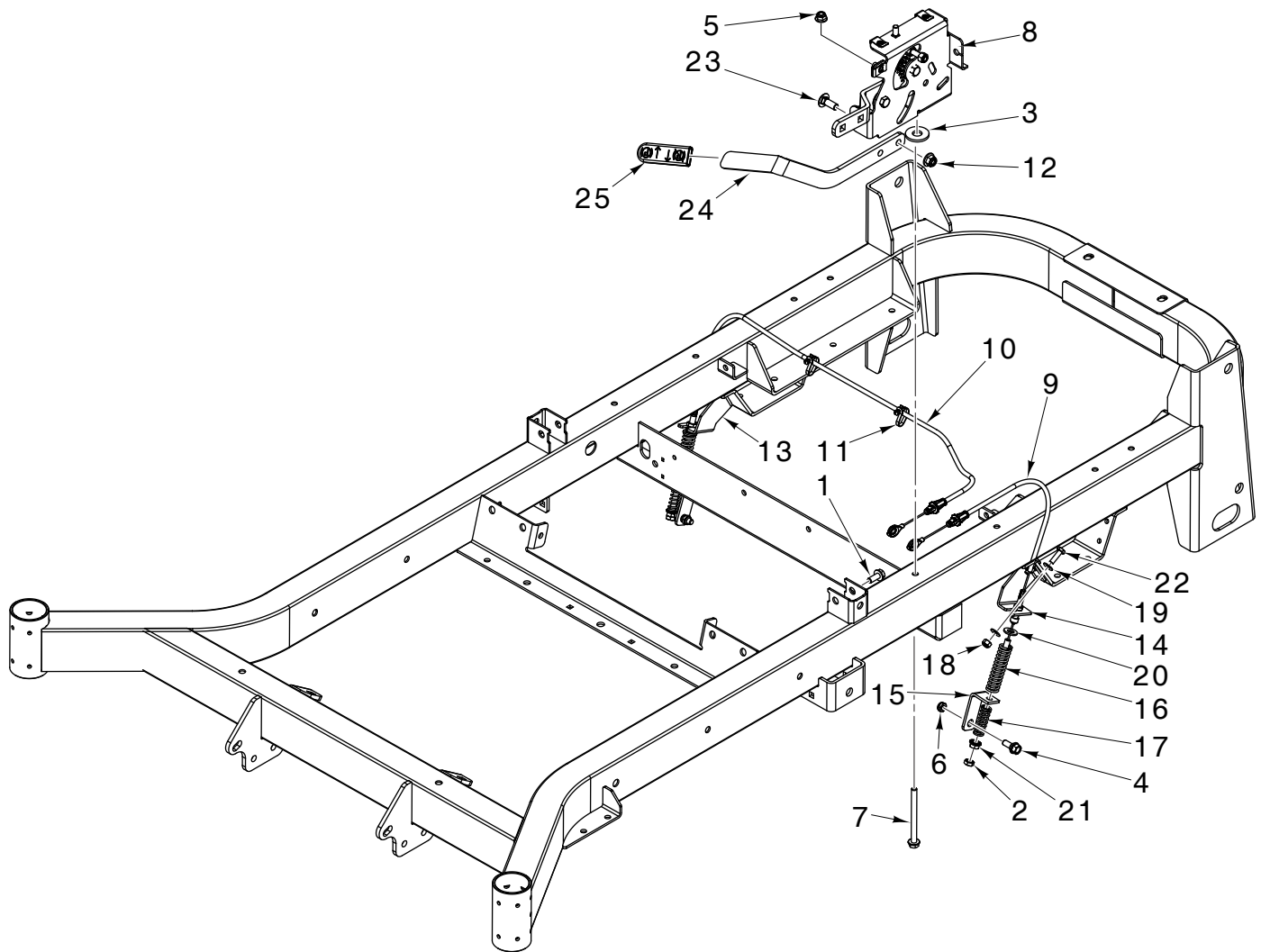

Ref.	Part No.	Description
1	592 85 87-02	BOLT 5/16-18X.75 HEX
2	596 43 63-01	NUT HEX 5/16-18 X 0.577
3	595 31 64-01	WASHER .563 X 1.375 X .096
4	596 24 07-01	BOLT HEX 5/16-18 X 21/32
5	594 94 44-01	NUT HEX 5/16-18
6	596 43 36-01	NUT 5/16-18 X 1/4 HEX
7	596 24 16-01	BOLT HEX 5/16-18 X 1 1/2
8	539 13 21-62	BRAKE ASSEMBLY
9	582 12 18-01	CABLE ASM BRAKE CABLE SHORT
10	582 12 20-01	CABLE ASM BRAKE CABLE LONG
11	505 28 00-01	TIE WRAP, 8-3/8", W/CLIP
12	521 99 65-02	NUT HEX LOCK W/FLANGE 3/8-16
13	593 27 92-02	BRACKET BRAKE RT

Ref.	Part No.	Description
14	593 27 99-02	BRACKET BRAKE LT
15	575 22 98-02	BRACKET BRAKE BLK
16	575 23 02-01	SPRING, RETURN
17	575 23 03-01	SPRING, ENGAGEMENT
18	595 08 66-01	NUT HEX 1/4-20 ST
19	596 13 30-01	WASHER FLAT 1/4
20	596 56 53-01	WASHER 3/8 X 0.08 IN ST
21	596 03 92-01	NUT LOCK HEX 5/16-18
22	596 56 54-01	HEX SCREW 1/4-20 X 7/8
23	595 31 68-01	BOLT CUP HEAD 3/8-16 X 1
24	593 56 40-02	ARM BRAKE
25	539 10 50-36	GRIP-PARK BRAKE

NOTE: All component dimensions given in U.S. inches. 1 inch = 25.4 mm
IMPORTANT: Use only Original Equipment Manufacturer (O.E.M.) replacement parts.
 Failure to do so could be hazardous, damage your product and void your warranty.

REPAIR PARTS

HYDRAULIC PUMP ASSEMBLY

ZTR - MODEL NO. Z448 (96798460100), PRODUCT NO. 967 98 46-01

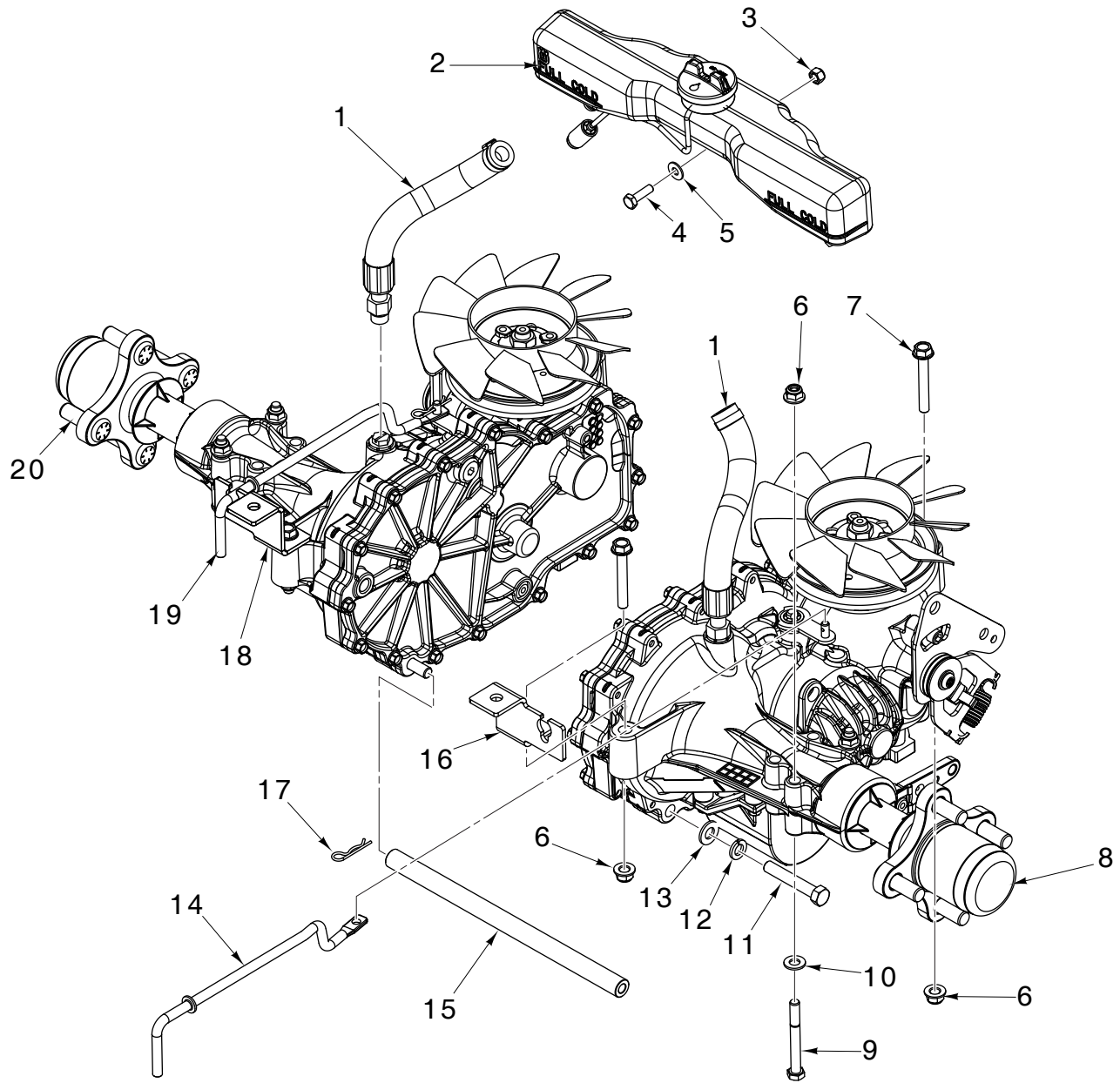

Ref.	Part No.	Description
1	574 89 21-01	HOSE ASM
2	585 31 82-01	TANK EXPANSION CAP
3	595 08 66-01	NUT HEX 1/4-20 ST
4	596 56 54-01	HEX SCREW 1/4-20 X 7/8
5	596 13 30-01	WASHER FLAT 1/4
6	594 94 44-01	NUT HEX 5/16-18
7	574 23 38-02	BOLT 5/16 X 2.25 GD5
8	577 22 77-01	TRANS, ZT-3100, RT
9	596 21 86-01	BOLT HEX 5/16-18 X 2-3/4
10	596 20 41-01	WASHER 11/32 X 11/16 X 14

Ref.	Part No.	Description
11	596 43 65-01	SCR 3/8-16 X 2-1/4" GR8
12	596 23 87-01	WASHER SPRING LOCK.
13	596 56 53-01	WASHER 3/8 X 0.08 IN ST
14	596 50 19-01	LINKAGE RIGHT BYPASS
15	574 86 85-02	SPACER TUBE
16	593 27 89-02	BRACKET PNT TRANS RT
17	596 58 06-01	PIN RETAINING 1-7/16 X 0.073
18	593 27 90-02	BRACKET PNT TRANS LT
19	596 50 07-01	LINKAGE LEFT BYPASS
20	577 22 77-02	TRANS, ZT-3100, LT

NOTE: All component dimensions given in U.S. inches. 1 inch = 25.4 mm
IMPORTANT: Use only Original Equipment Manufacturer (O.E.M.) replacement parts.
 Failure to do so could be hazardous, damage your product and void your warranty.

REPAIR PARTS

HYDRAULIC PUMP ASSEMBLY

ZTR - MODEL NO. Z448 (96798460100), PRODUCT NO. 967 98 46-01

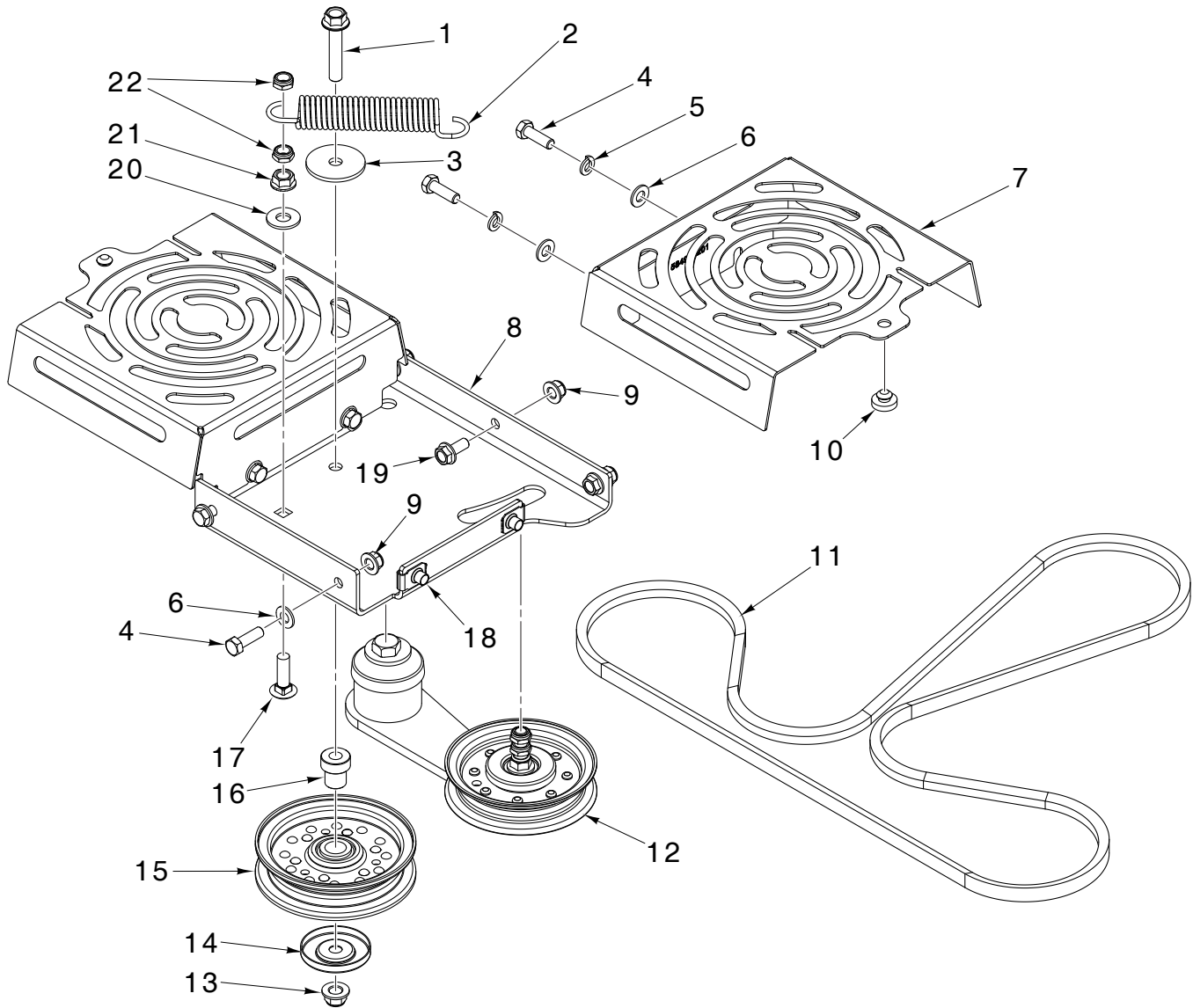

Ref.	Part No.	Description
1	596 31 94-01	BOLT HEX 3/8-16 X 2.0
2	510 25 44-02	SPRING PUMP
3	596 91 73-01	WASHER 3/8
4	596 58 08-01	BOLT HEX SCREW 5/16-18 X 1
5	596 23 88-01	WASHER LOCK 5/16
6	596 20 41-01	WASHER 11/32 X 11/16 X 14
7	584 99 42-02	SHIELD FAN BLK
8	586 67 04-02	PLATE PNT IDLER SUPPORT
9	594 94 44-01	NUT HEX 5/16-18
10	539 10 25-87	GROMMET, BUMPER
11	574 87 09-01	BELT, HYDRO, 3400

Ref.	Part No.	Description
12	575 23 01-01	ASM, IDLER ARM, 3400
13	521 99 65-02	NUT HEX LOCK 3/8-16
14	510 25 45-02	DUST SHIELD
15	596 73 98-01	PULLEY-IDLER
16	525 43 56-01	PIVOT, IDLER
17	595 90 11-01	BOLT 3/8-16 X 1.27
18	539 10 47-63	NUT 5/16-18 RETAINER-U TYPE
19	592 85 87-02	BOLT 5/16-18 X .75 HEX FLANGE
20	596 43 37-01	WASHER 3/8 X 0.453 X 1.030
21	596 58 35-01	WASHER HEX 3/8-16 X .765
22	596 23 08-01	NUT PREVAIL 3/8-19 X .564

NOTE: All component dimensions given in U.S. inches. 1 inch = 25.4 mm
IMPORTANT: Use only Original Equipment Manufacturer (O.E.M.) replacement parts. Failure to do so could be hazardous, damage your product and void your warranty.

REPAIR PARTS

WHEELS AND TIRES

ZTR - MODEL NO. Z448 (96798460100), PRODUCT NO. 967 98 46-01

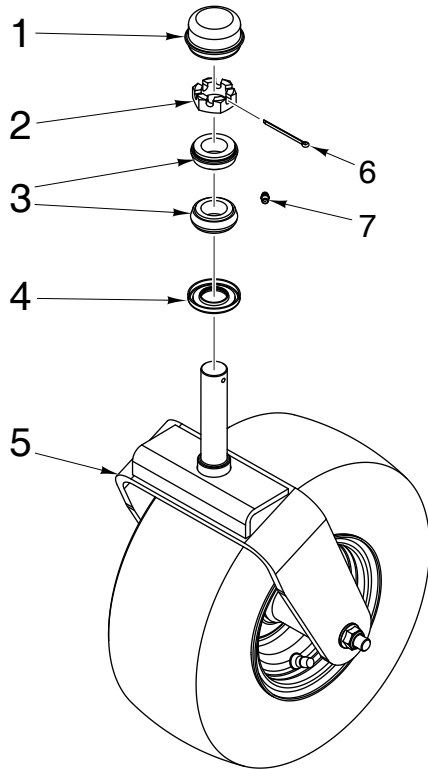

Ref.	Part No.	Description
1	595 28 13-01	CAP GREASE
2	596 24 15-01	NUT.HEX.1-14 X 1-1/2
3	539 10 25-43	BRG-ROLLER TAPERED
4	539 10 28-51	SEAL
5	587 61 81-01	CASTER.ASM.ORANGE/SILVER
6	595 52 88-01	PIN.COTTER.1/8 X 2
7	596 62 35-01	VALVE.ZERK.1/2.DRIVE IN

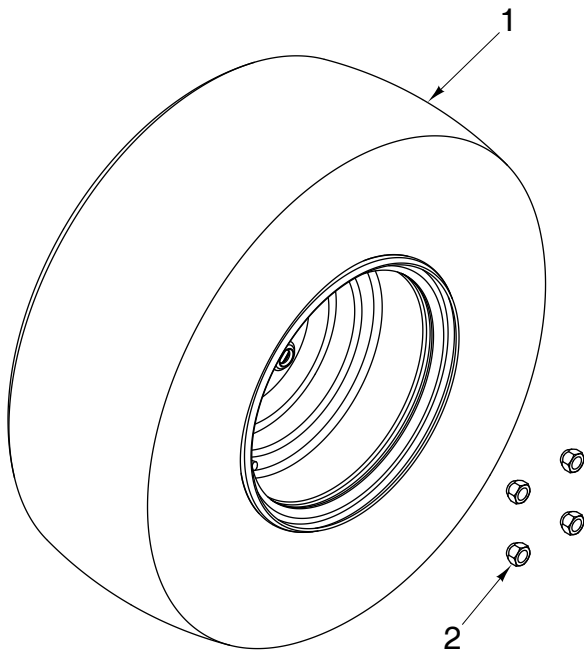

Ref.	Part No.	Description
1	580 74 70-01	TIRE & WHEEL ASSEMBLY
2	587 65 39-02	NUT 1/2-20 UNF-2B GR 8

NOTE: All component dimensions given in U.S. inches. 1 inch = 25.4 mm
IMPORTANT: Use only Original Equipment Manufacturer (O.E.M.) replacement parts.
 Failure to do so could be hazardous, damage your product and void your warranty.

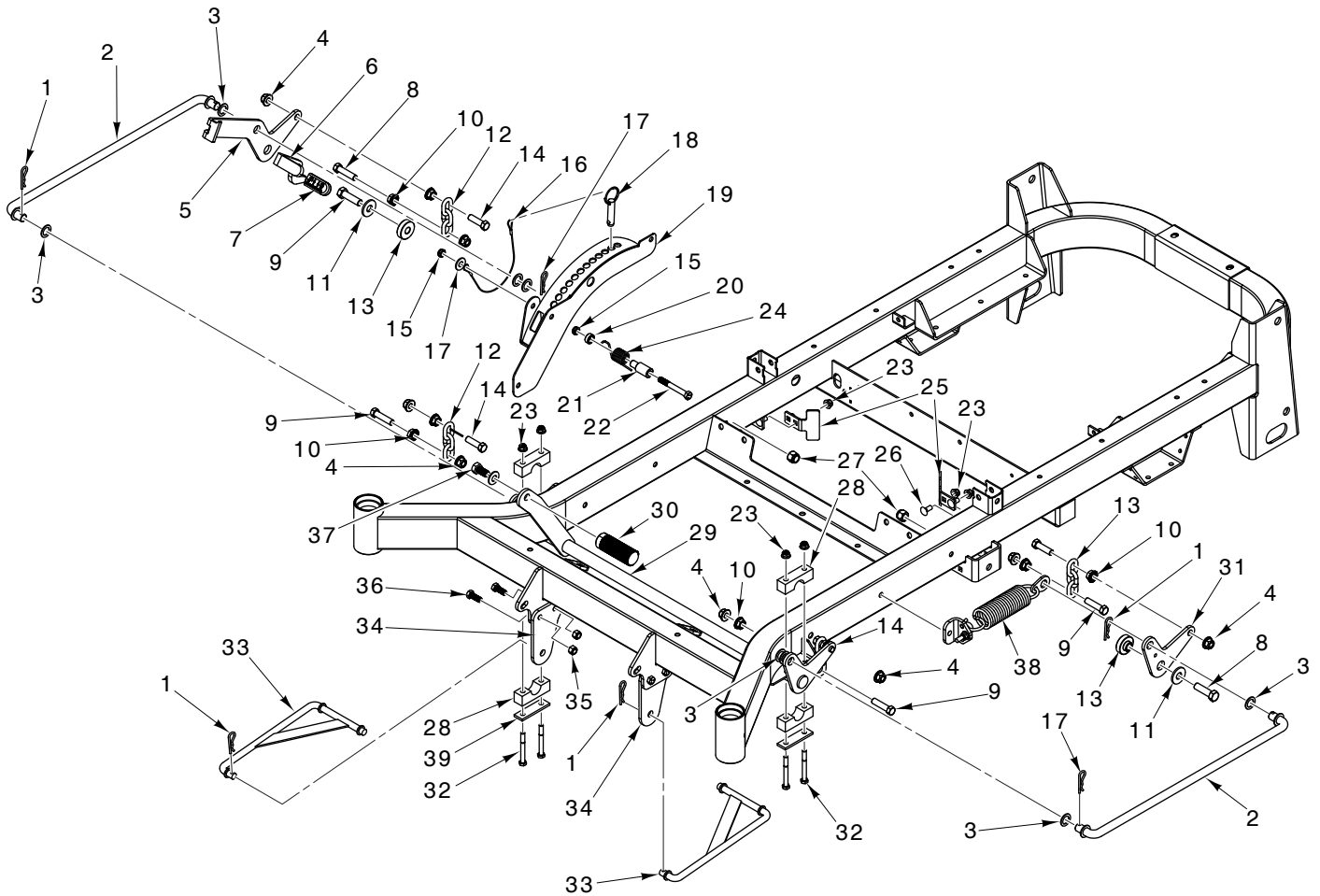

NOTE: All component dimensions given in U.S. inches. 1 inch = 25.4 mm
IMPORTANT: Use only Original Equipment Manufacturer (O.E.M.) replacement parts.
Failure to do so could be hazardous, damage your product and void your warranty.

REPAIR PARTS**DECK LIFT****ZTR - MODEL NO. Z448 (96798460100), PRODUCT NO. 967 98 46-01**

Ref.	Part No.	Description
1	596 91 96-01	COTTER PIN
2	596 61 52-01	CROSS LINK
3	596 93 34-01	WASHER 21/32 X 1 X 16
4	594 99 33-01	NUT 7/16-14 HEX
5	592 87 77-02	BELL CRANK, REAR
6	596 78 33-01	LATCH - TRANSPORT
7	539 13 28-51	GRIP - TRANSPORT
8	596 43 58-01	BOLT 1/2-13 X 1-3/4
9	596 43 85-01	BOLT 7/16-14 x 1-3/4
10	596 57 79-01	NUT 7/16-14 HEX
11	595 31 64-01	WASHER 9/16 X 1 3/8 X 12
12	594 72 20-01	LIFT CHAIN
13	586 70 17-02	IDLER SPACER
14	594 94 46-01	BOLT 7/16-14 X 1-1/2
15	596 23 08-01	NUT 3/8-16 HEX
16	539 10 50-59	LANYARD
17	596 43 37-01	WASH 3/8 FLAT
18	596 91 79-01	PIN 1/2 X 1-1/2
19	596 48 84-01	HEIGHT ADJUST DECK
20	596 51 52-01	SPACER
21	596 51 74-01	PIVOT LATCH
22	596 56 44-05	BOLT HEX 3/8-16 X 3
23	594 94 44-01	NUT 5/16-18 HEX FLANGE
24	596 47 92-01	SPRING
25	593 63 43-02	STOP - DECK
26	595 90 16-01	BOLT 5/16-18 X 3/4
27	596 13 56-01	NUT 1/2-13 HEX
28	539 10 48-08	BLOCK - PILLOW
29	586 92 87-02	LIFT - DECK
30	510 40 83-02	PEDAL - DECK HEIGHT
31	539 13 18-97	BELL CRANK
32	596 21 86-01	BOLT 5/16-18 X 2-3/4
33	539 11 22-23	STRUT LINKAGE
34	539 13 17-86	MOUNT, STRUT
35	596 24 09-01	NUT 3/8-16 HEX
36	596 56 44-01	BOLT 3/8-16 X 1
37	596 58 36-01	BOLT 1/2-13 X 1
38	539 13 17-90	SPRING - DECK, LIFT
39	584 39 27-02	REINFORCEMENT PLATE

NOTE: All component dimensions given in U.S. inches. 1 inch = 25.4 mm
IMPORTANT: Use only Original Equipment Manufacturer (O.E.M.) replacement parts.
 Failure to do so could be hazardous, damage your product and void your warranty.

REPAIR PARTS

MOWER DECK

ZTR - MODEL NO. Z448 (96798460100), PRODUCT NO. 967 98 46-01

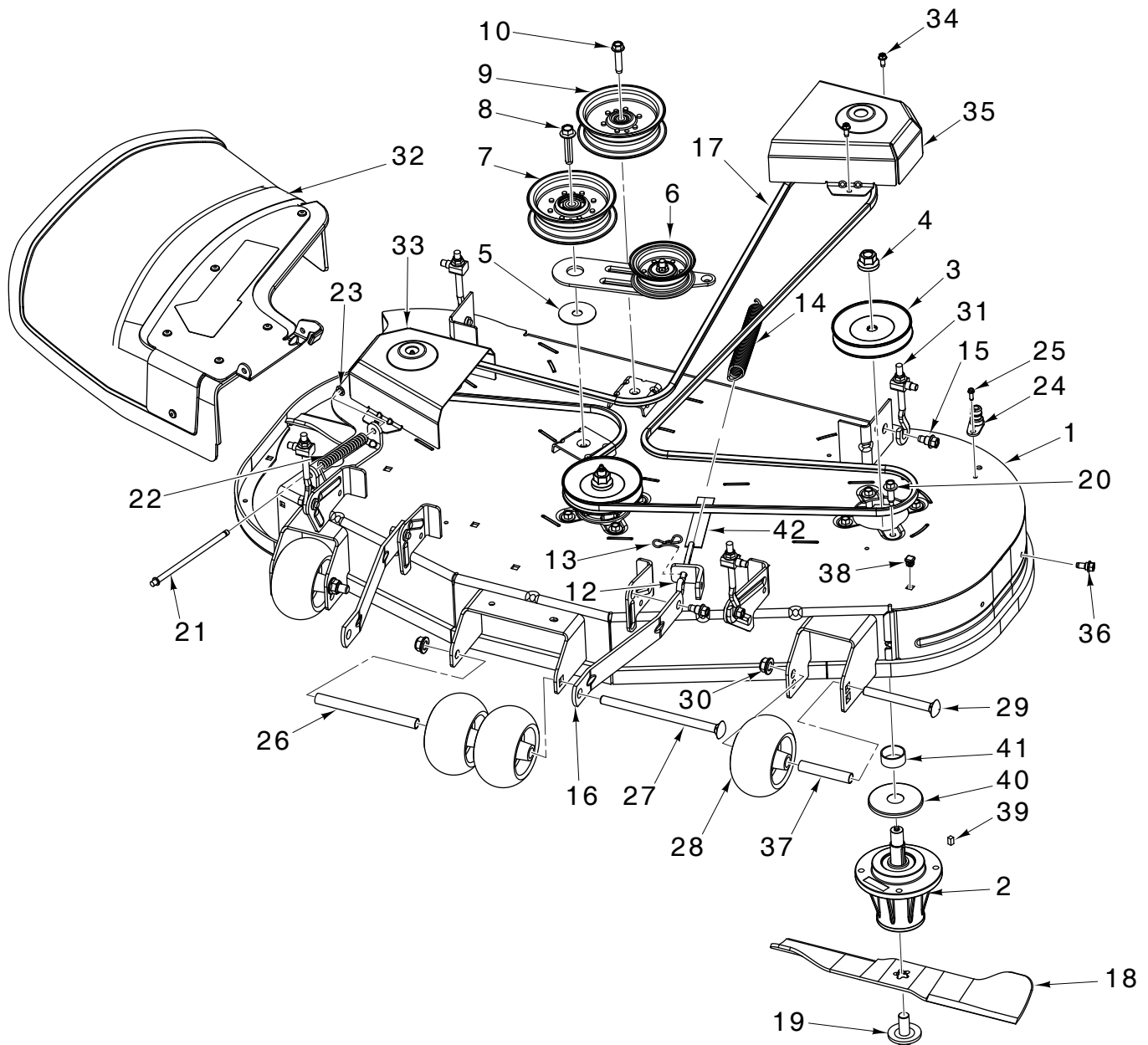

NOTE: All component dimensions given in U.S. inches. 1 inch = 25.4 mm

IMPORTANT: Use only Original Equipment Manufacturer (O.E.M.) replacement parts. Failure to do so could be hazardous, damage your product and void your warranty.

REPAIR PARTS**MOWER DECK****ZTR - MODEL NO. Z448 (96798460100), PRODUCT NO. 967 98 46-01**

Ref.	Part No.	Description
1	598 85 27-01	DECK SHELL ASSY 48
2	539 11 21-70	SPINDLE ASSY
3	590 80 51-03	PULLEY WITH HUB
4	598 49 05-01	NUT - FLANGE 3/4-16
5	532 17 85-15	WASHER
6	588 81 23-04	ARM CLUTCHING ASSY
7	532 19 61-04	PULLEY IDLER
8	588 43 83-01	SCREW 7/16-14 X 2.125
9	532 19 61-06	PULLEY IDLER
10	596 56 40-03	BOLT HEX HEAD BOLT 3/8-16 X 1.78
11	596 24 08-01	BOLT EYELET BOLT 5/16-18 X 3-1/2 IN
12	597 84 51-01	PIN DECK BELT TENSION
13	532 19 42-08	LOCKING COTTER BOW TIE
14	582 50 40-01	SPRING EXTENSION
15	532 19 65-39	SHOULDER BOLT
16	587 14 05-02	ARM REAR FIXED MOWER SUSPENSION
17	579 67 85-02	BELT DECK 147.50 EL
18	588 81 12-02	BLADE 48
19	539 11 90-07	SCREW HEX
20	584 95 39-01	BOLT 5/16-18UNC X 1.25
21	595 29 70-01	ROD HINGE

Ref.	Part No.	Description
22	587 35 47-01	SPRING 42 DEFLECTOR SPRING
23	532 11 04-52	NUT
24	532 41 55-98	HOSE COUPLING WASHOUT
25	596 63 73-01	SCREW 1/4-20X5/8 HEX SELF TAP
26	574 19 65-02	TUBE ROLLER AXLE LONG
27	594 94 45-01	BOLT CUP HEAD 1/2-13 X 8.0 G5
28	574 16 96-01	ROLLER GAUGE 5 in. .635 BORE
29	510 02 23-02	SCREW CUP HEAD 1/2-13 X 4 3/4
30	521 99 11-02	NUT 1/2-13 HEX FLANGE
31	588 78 34-01	LINK ASSY ADJUSTABLE
32	593 64 97-01	DEFLECTOR ASSY 48 CLEARCUT
33	588 81 24-02	COVER 48 CLEARCUT RH MANDREL
34	532 13 77-29	SCREW
35	588 81 28-02	COVER 48 CLEARCUT ZTR LH MANDREL
36	817 00 05-10	BOLT HEX 5/16-18
37	574 19 64-02	TUBE GAGE ROLLER AXLE
38	596 95 22-01	PLUG
39	587 68 28-01	KEY
40	598 44 00-01	CAP UPPER DUST
41	598 64 55-01	SPACER
42	532 42 54-17	VIBRATION PAD

NOTE: All component dimensions given in U.S. inches. 1 inch = 25.4 mm
IMPORTANT: Use only Original Equipment Manufacturer (O.E.M.) replacement parts.
 Failure to do so could be hazardous, damage your product and void your warranty.

REPAIR PARTS

SEAT ASSEMBLY

ZTR - MODEL NO. Z448 (96798460100), PRODUCT NO. 967 98 46-01

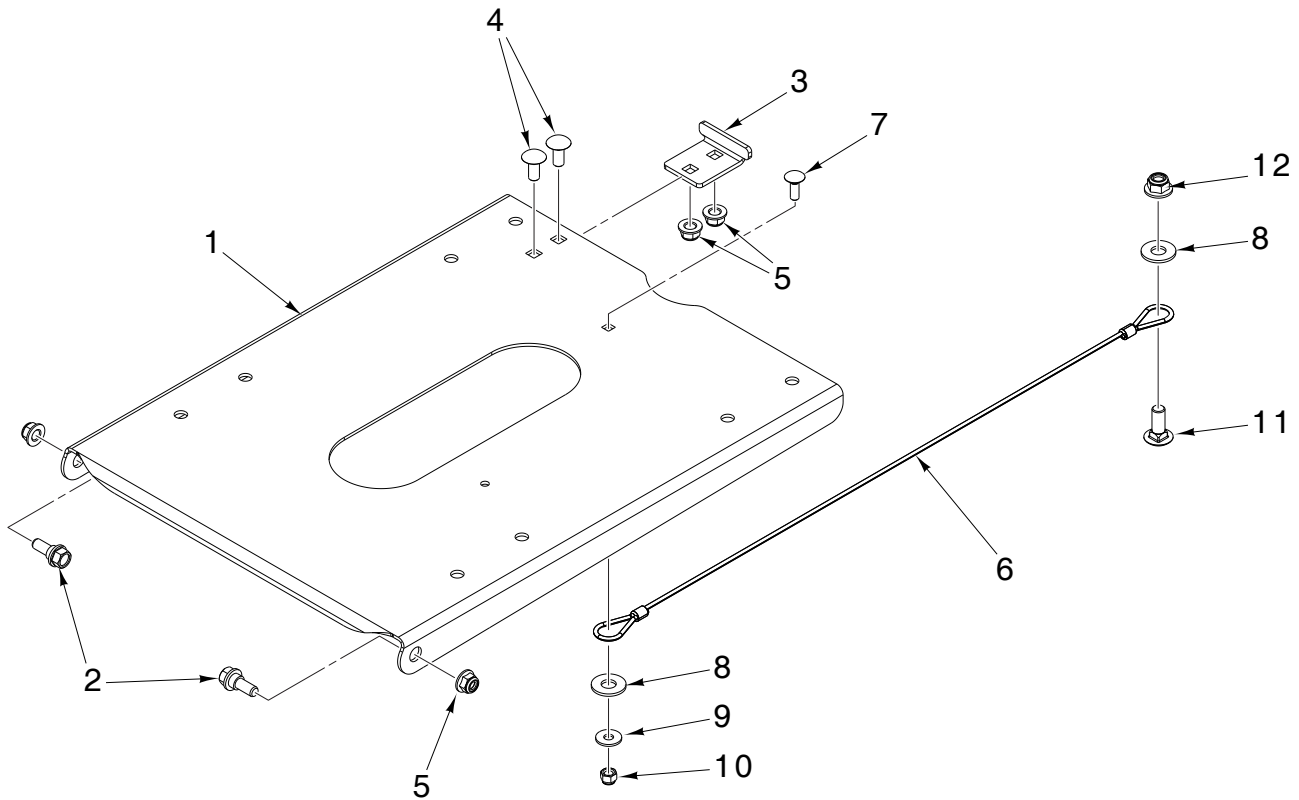

Ref.	Part No.	Description
1	501 76 21-02	SUPPORT SEAT ORANGE
2	539 13 08-96	BOLT 5/16-18 HEX
3	539 13 07-93	STOP, SEAT - BLACK
4	872 05 05-06	BOLT 5/16-18 X 3/4
5	594 94 44-01	NUT HEX FLNG 5/16-18
6	539 10 32-47	SEAT LANYARD

Ref.	Part No.	Description
7	596 23 84-01	BOLT CARR 1/4-20 X 3/4
8	596 43 37-01	WASHER 3/8 X 0.453 X 1.030
9	596 20 42-01	WASHER FLAT .281 X .750 X .051
10	595 08 66-01	NUT HEX 1/4-20 ST
11	595 31 68-01	BOLT CUP HEAD SQR 3/8-16 X1
12	521 99 65-02	NUT HEX LOCK W/FLANGE 3/8-16

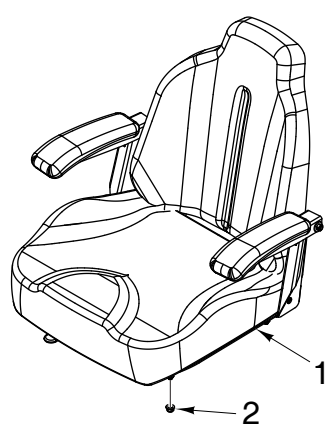

Ref.	Part No.	Description
1	501 58 04-02	SEAT W/O BELT
2	594 94 44-01	NUT HEX 5/16-18

NOTE: All component dimensions given in U.S. inches. 1 inch = 25.4 mm
IMPORTANT: Use only Original Equipment Manufacturer (O.E.M.) replacement parts. Failure to do so could be hazardous, damage your product and void your warranty.

REPAIR PARTS

SEAT ASSEMBLY

ZTR - MODEL NO. Z448 (96798460100), PRODUCT NO. 967 98 46-01

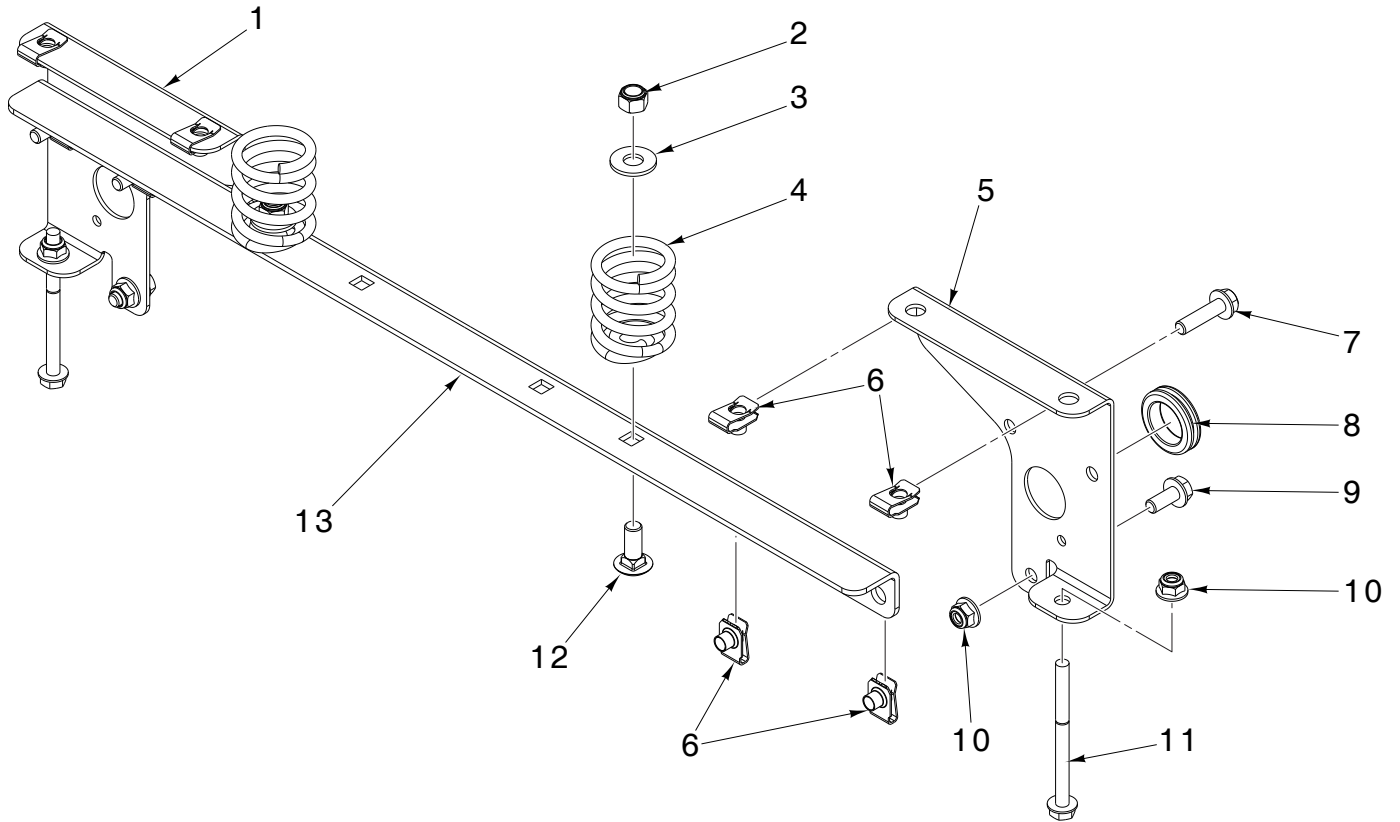

Ref.	Part No.	Description
1	584 99 01-02	SUPPORT RT BLK
2	596 24 09-01	NUT PREVAIL 3/8-16 X .564
3	596 43 37-01	WASHER 3/8 X .0.453 X 1.030
4	587 61 33-01	SPRING COMPRESSION SEAT CYL
5	584 99 02-02	SUPPORT LT BLK
6	539 10 47-63	NUT 5/16-18 RETAINER-U TYPE
7	525 54 40-02	BOLT HEXAGON HEAD 5/16-18X1.25
8	539 10 59-74	GROMMET-RUBBER
9	592 85 87-02	BOLT 5/16-18 X .75 HEX FLANGE
10	594 94 44-01	NUT HEX FLNG .5/16-18
11	874 49 05-60	BOLT HEX 5/16-18 X 3.75
12	595 31 68-01	BOLT CUP HEAD SQR NCK 3/8-16X1
13	593 14 44-02	SUPPORT SEAT

NOTE: All component dimensions given in U.S. inches. 1 inch = 25.4 mm
IMPORTANT: Use only Original Equipment Manufacturer (O.E.M.) replacement parts.
 Failure to do so could be hazardous, damage your product and void your warranty.

ZTR - MODEL NO. Z448 (96798460100), PRODUCT NO. 967 98 46-01

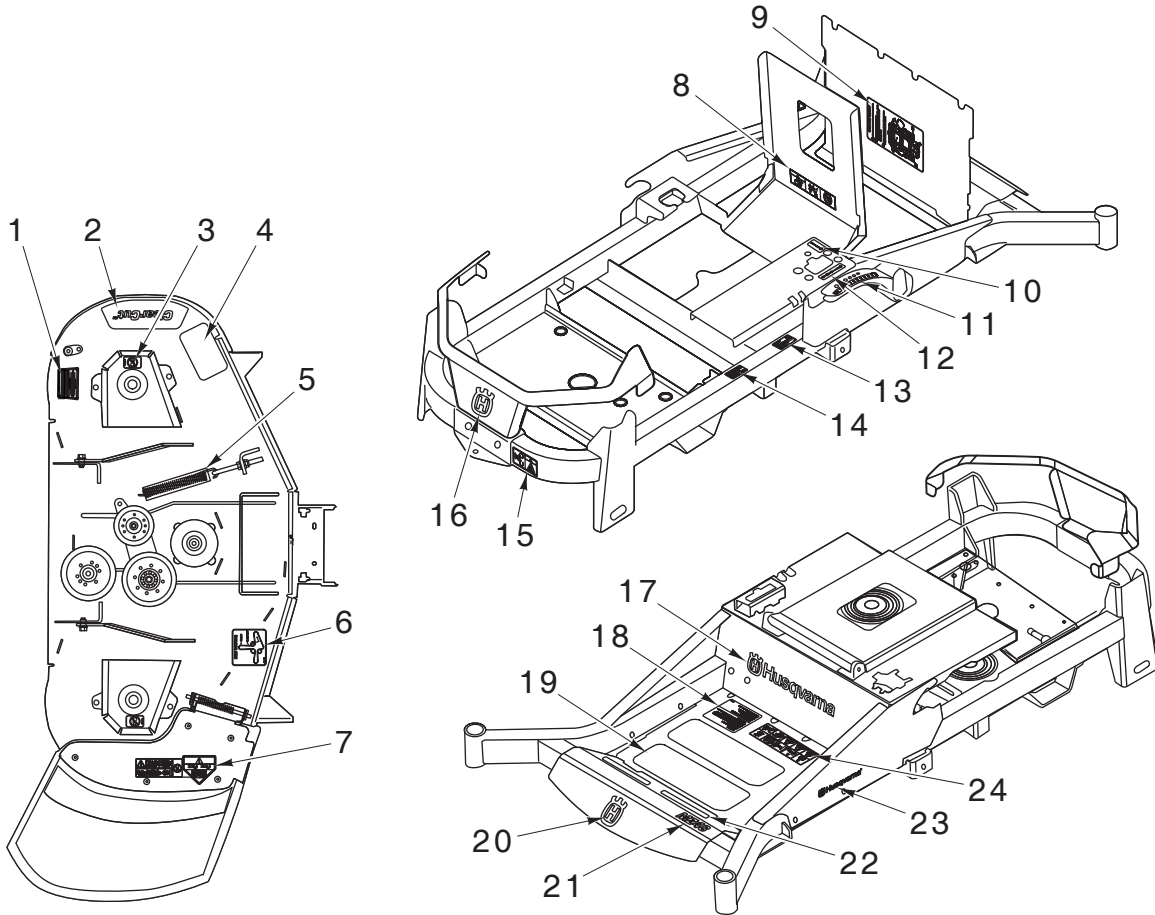

Ref.	Part No.	Description
1	592 89 83-01	DECAL DECK WARRANTY
2	590 88 50-01	DECAL 48"DECK CLEARCUT
3	589 35 79-01	DECAL DECK NO STEP
4	539 12 13-22	FOOT PAD
5	425417	VIBRATION PAD
6	539 11 26-20	DECAL BELT ROUTING
7	586 97 88-01	DECAL DECK WARNING

Ref.	Part No.	Description
8	539 10 57-45	DECAL BATTERY WARNING
9	539 13 21-87	DECAL SERVICE
10	585 14 26-01	DECAL STR SYMBOLS
11	539 13 20-39	DECAL HEIGHT ADJUST
12	589 28 30-01	DECAL MOTION CONTROL
13	441571	DECAL
14	597 99 89-01	DECAL
15	539 10 57-44	DECAL DANGER, BELT
16	574 45 50-01	DECAL CROWN H 110MM
17	591 35 74-01	DECAL LOGO SEAT PLATE
18	586 34 25-01	DECAL
19	539 97 77-78	DECAL
20	428676	DECAL CROWN
21	589 48 06-01	DECAL Z448
22	539 12 13-22	DECAL
23	429196	DECAL BADGE 170MM
24	590 48 55-01	DECAL WARNING YELLOW

NOTE: All component dimensions given in U.S. inches. 1 inch = 25.4 mm
IMPORTANT: Use only Original Equipment Manufacturer (O.E.M.) replacement parts. Failure to do so could be hazardous, damage your product and void your warranty.

