

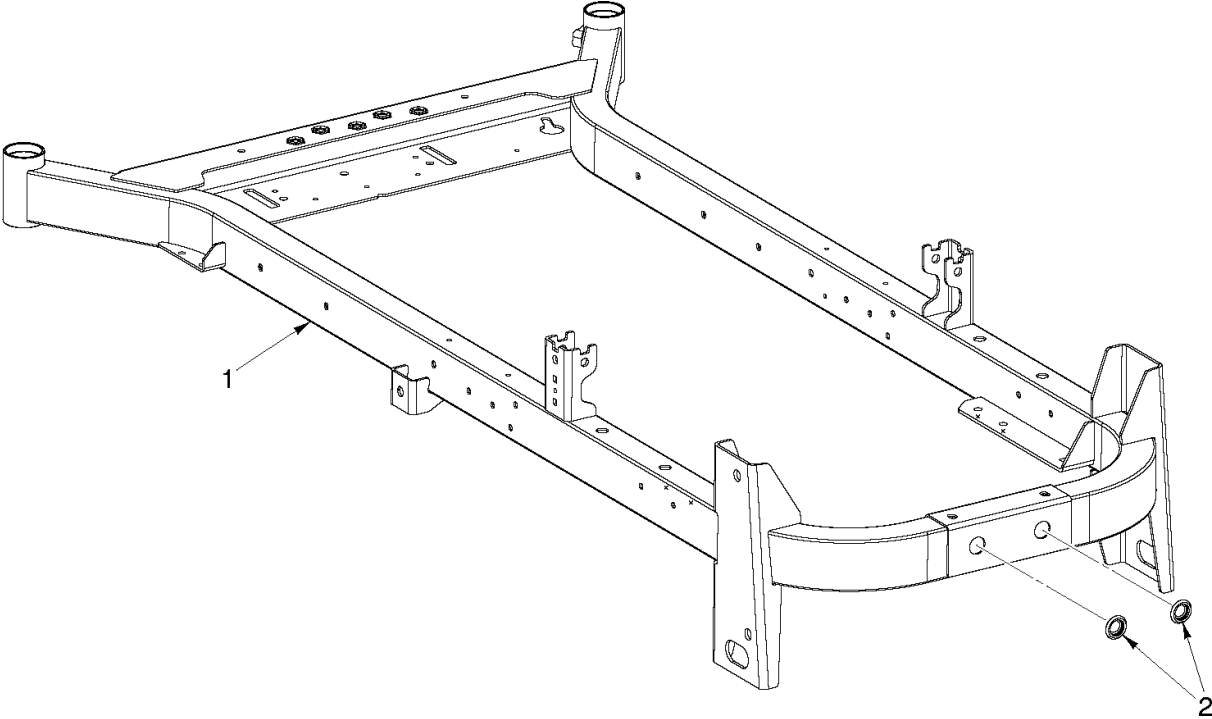

# SPARE PARTS LIST

ZERO TURN: COMMERCIAL  
Z454, 967984701-00, 2019-12



FRAME - CHASSIS

Z454, 967984701-00, 2019-12

Ref	Part No	Description	Remark	QTY KIT
1	501 65 60-06	FRAME	KIT FRAME WITH DECALS	1
2	587 99 05-01	CAP	CAP PLUG BP-1 BLACK	2

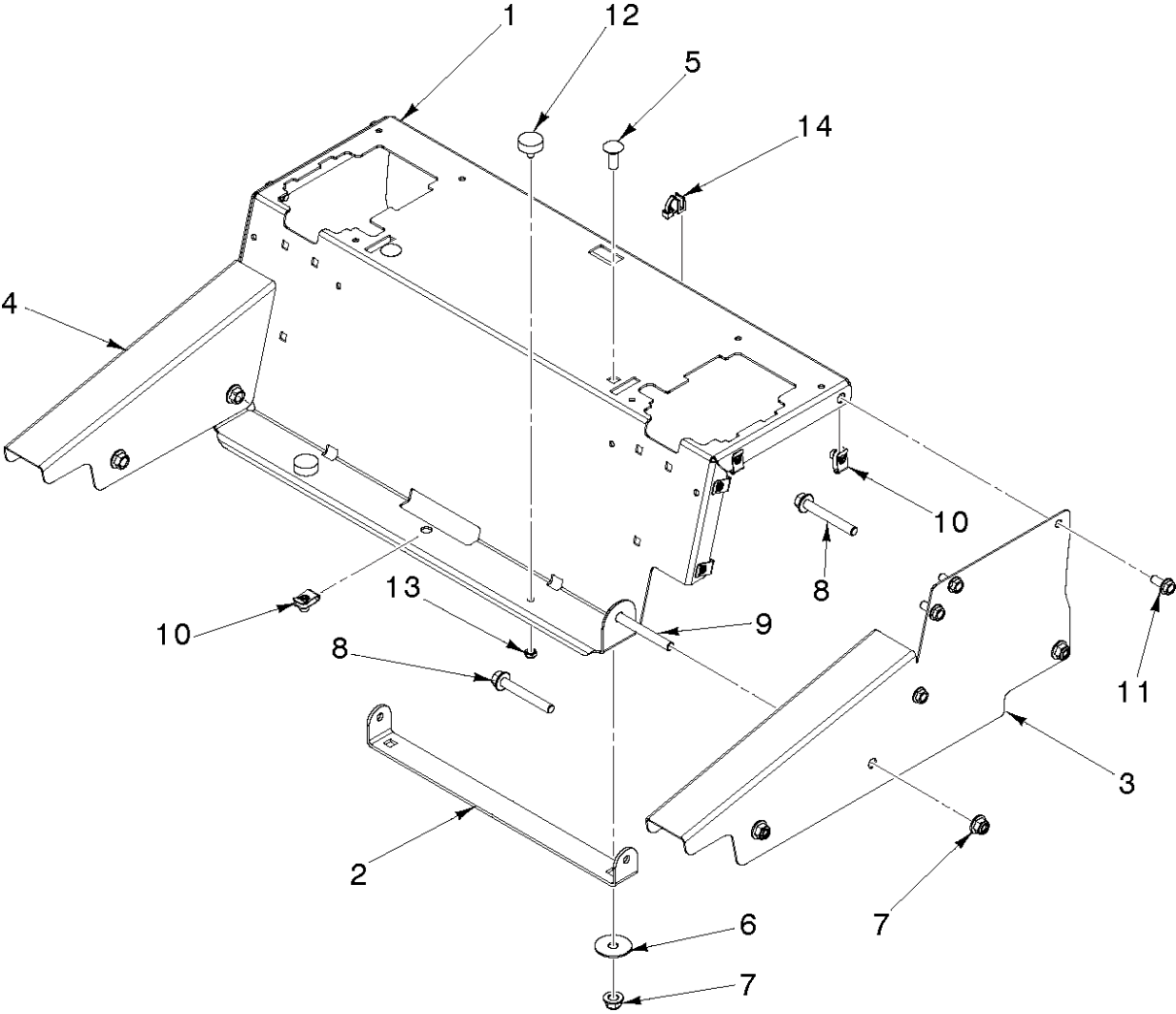

## FRAME - SEAT DECK

Z454, 967984701-00, 2019-12

Ref	Part No	Description	Remark	QTY KIT
1	595 30 66-02	SUPPORT	SEAT DECK, Z300/Z400 ORANGE	1
2	595 30 67-02	BRACKET	SEAT MOUNT Z300/Z400 BLACK	1
3	595 31 10-03	PLATE	PLATE WEDGE, Z300/Z400 ORANGE	1
4	595 31 10-04	PLATE	PLATE WEDGE, Z300/Z400 ORANGE	1
5	595 31 68-01	BOLT	BOLT 3/8-16UNC X 1 " Grade 5 ZPB	2
6	596 13 33-01	WASHER	WASHER 13/32 x 1 1/2 IN ST	2
7	521 99 65-02	NUT	NUT HEX LOCK FLANGE 3/8-16 St	9
8	596 43 69-01	SCREW	SCREW W/ COLLAR 3/8- 16 X 2-3/4	5
9	577 11 77-02	BOLT	BOLT 3/8-16 x 3	2
10	539 10 47-63	CLIP	U-CLIP 5/16-18 NUT RETAINER	9
11	592 85 87-02	BOLT	BOLT 5/16-18 X .75 HEX FLANGE	8
12	575 81 15-01	BUMPER	BUMPER 1/4-20 STUD 1/4	2
13	596 03 15-01	LOCK NUT	LOCK NUT NYLOC 0.188 x 0.218 IN	2
14	595 30 62-01	ZIP TIRE	ZIP TIRE PANEL EDGE CLIP BLACK	2

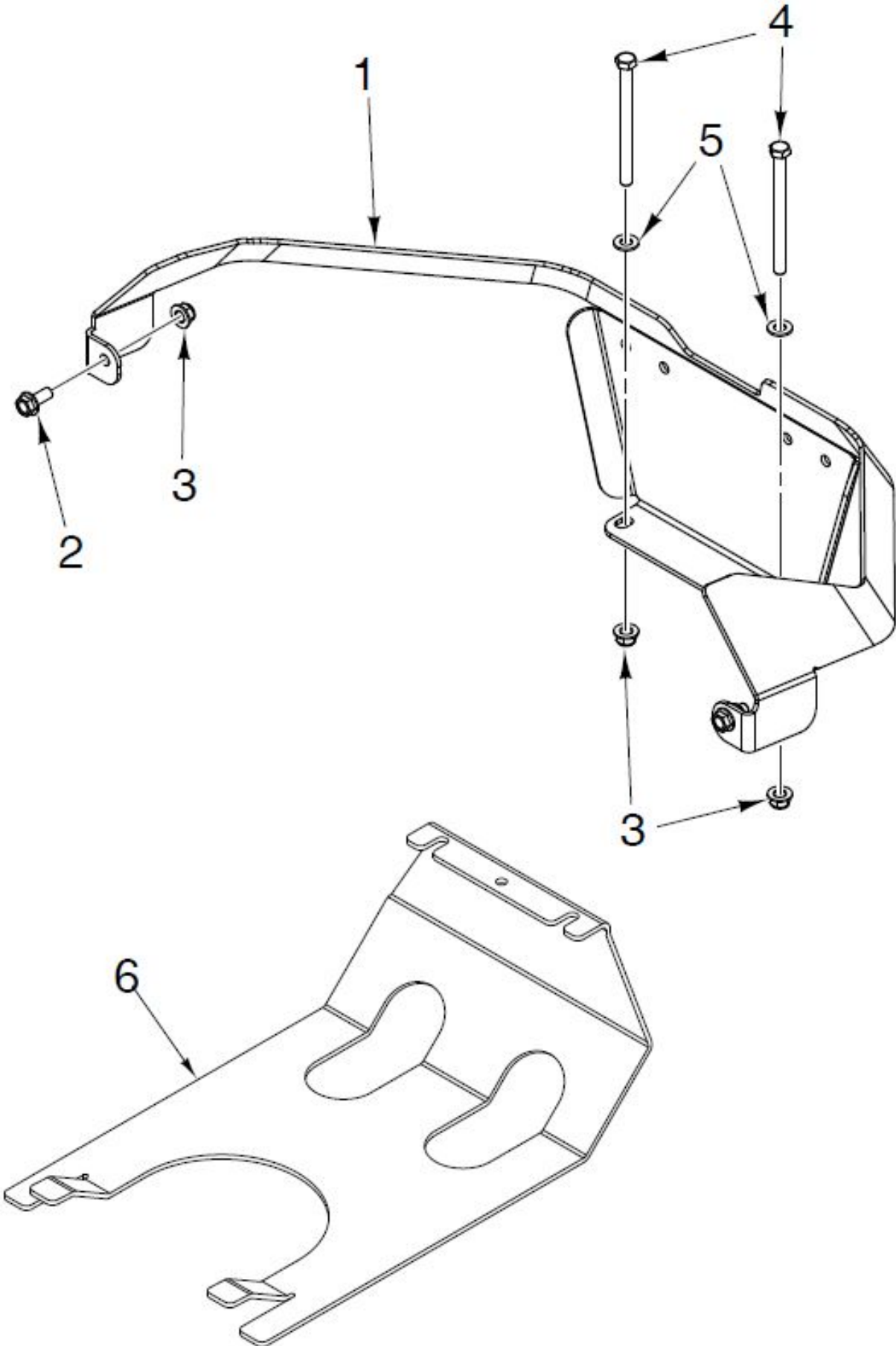

## FRAME - REAR GUARDS

Z454, 967984701-00, 2019-12

Ref	Part No	Description	Remark	QTY KIT
1	582 69 37-02	GUARD	GUARD REAR, MZ GRAY X498	1
2	592 85 87-02	BOLT	BOLT 5/16-18 X .75 HEX FLANGE	2
3	594 94 44-01	NUT	NUT HEXAGON FLANGE 5/16-18	4
4	596 43 55-01	BOLT	BOLT HEX HD 5/16-18UNC X 4"	2
5	596 20 41-01	WASHER	WASHER 11/32 X 11/16 X 14	2
6	593 79 55-05	GUARD		1

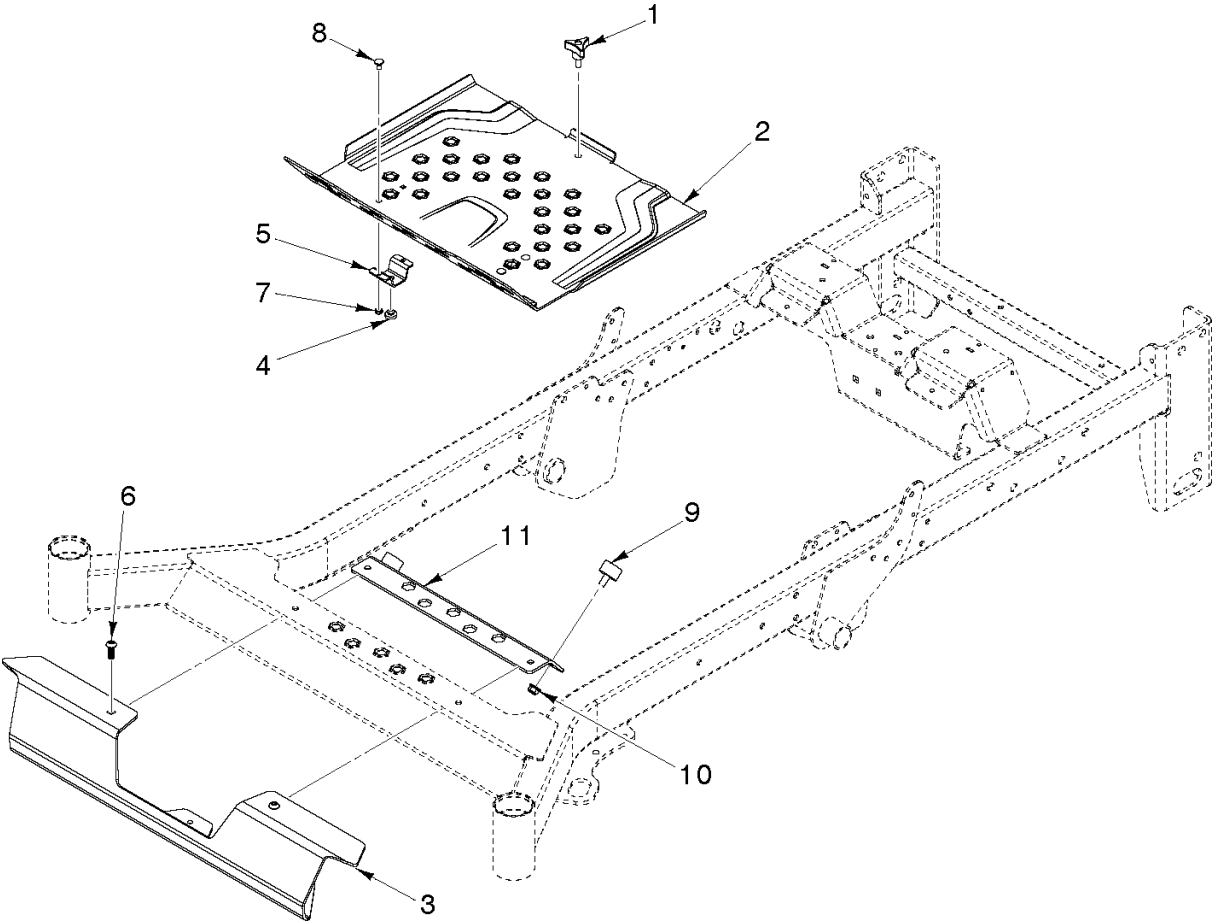



## FRAME - FOOT PLATE

Z454, 967984701-00, 2019-12

Ref	Part No	Description	Remark	QTY KIT
1	539 10 44-11	KNOB	KNOB W/STUD	1
2	589 30 46-02	PLATE	PLATE FLOOR PAN ORANGE	1
3	589 74 52-02	COVER	COVER VALANCE PZ GREY	1
4	539 10 25-87	ABSORBER	ABSORBER VIBRATION GROMMET	2
5	589 80 88-02	BRACKET	BRACKET FLOOR PAN BUMPER	2
6	589 79 72-01	SCREW	SCREW BUTTON HEAD 3/8-16 X 1	2
7	539 10 81-20	NUT	NUT 1/4-20 HEX THIN NYLOC ZY	4
8	872 14 04-04	BOLT	BOLT	4
9	589 74 40-01	ISOLATOR	ISOLATOR PZ FOOTREST	2
10	521 99 65-01	NUT	NUT 3/8-16 HEX FLANGE NYLOC ZY	2
11	589 80 72-02	BRACKET	BRACKET ISOLATOR SUPPORT	1

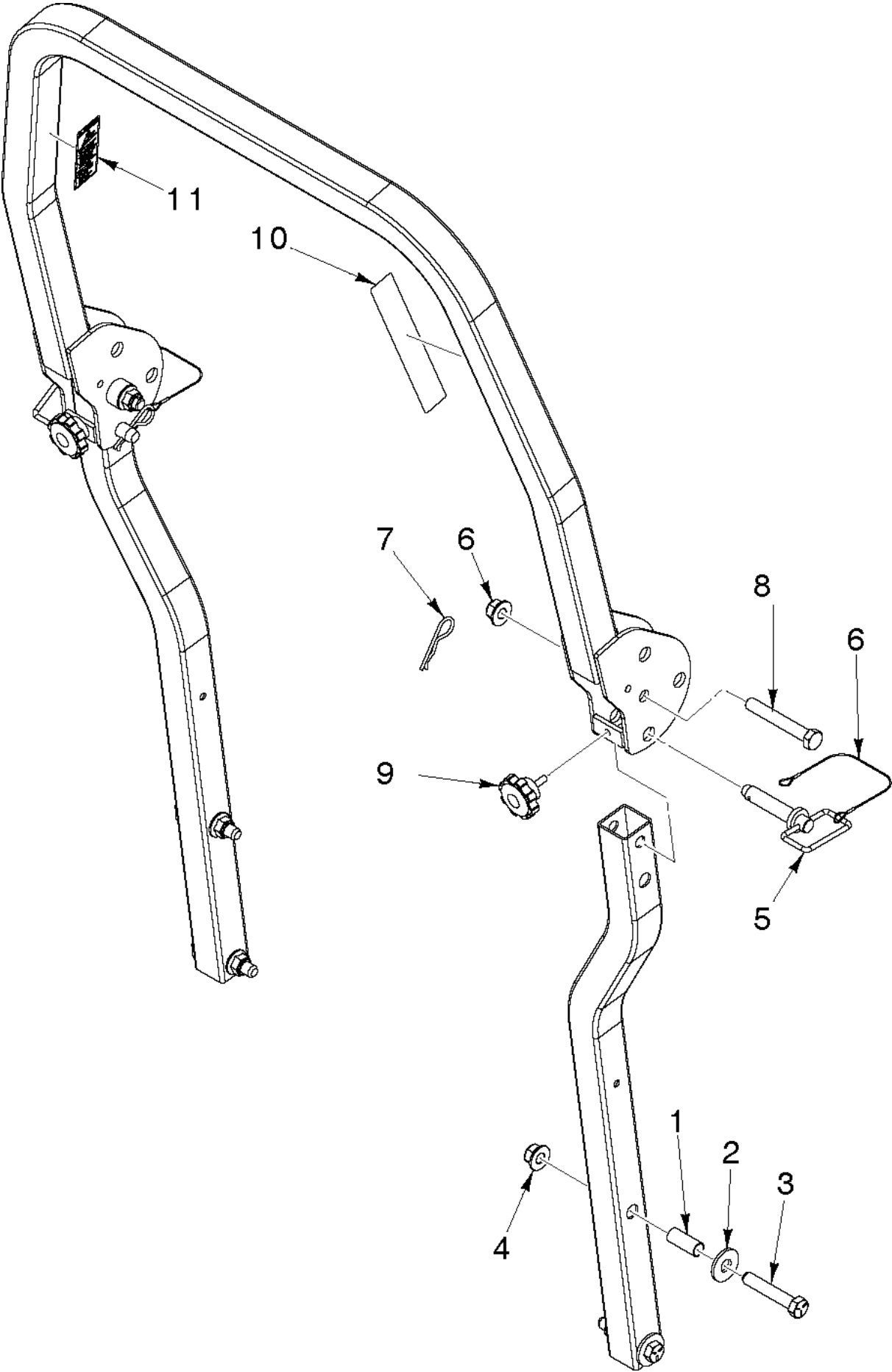

## FRAME - ROLL PROTECTION

Z454, 967984701-00, 2019-12

Ref	Part No	Description	Remark	QTY	KIT
1	597 07 06-01	SPACER	SPACER	4	
2	594 94 64-01	WASHER	WASHER PLAIN .688X1.75X.138	4	
3	580 75 46-02	BOLT	BOLT HEX HD 5/8-11UNC X 3,5 "	4	
4	525 82 91-02	NUT	NUT 5/8-11 FLANGE NYLOC	6	
5	591 10 16-02	PIN	PIN W/ HANDLE CLEAR ZINC	2	
6	591 10 17-02	PIN	WIRE LANYARD DOUBLE LOOPED	2	
7	596 91 80-01	PIN	PIN COTTER 0.148 X 2- 15/16 IN ST	2	
8	591 17 66-02	BOLT	BOLT HEX 5/8-11 x 4-1/4 IN	1	
9	591 34 45-01	KNOB	KNOB 5/16-18 X 1"	1	
10	597 75 87-01	DECAL	DECAL	1	
11	574 56 90-02	DECAL	DECAL WARNING	1	
	598 42 91-01	ROPS	COMPLETE ROPS W/ SEATBELT	1	1,2,3,4,5 ,6,7,8,9, 10,11

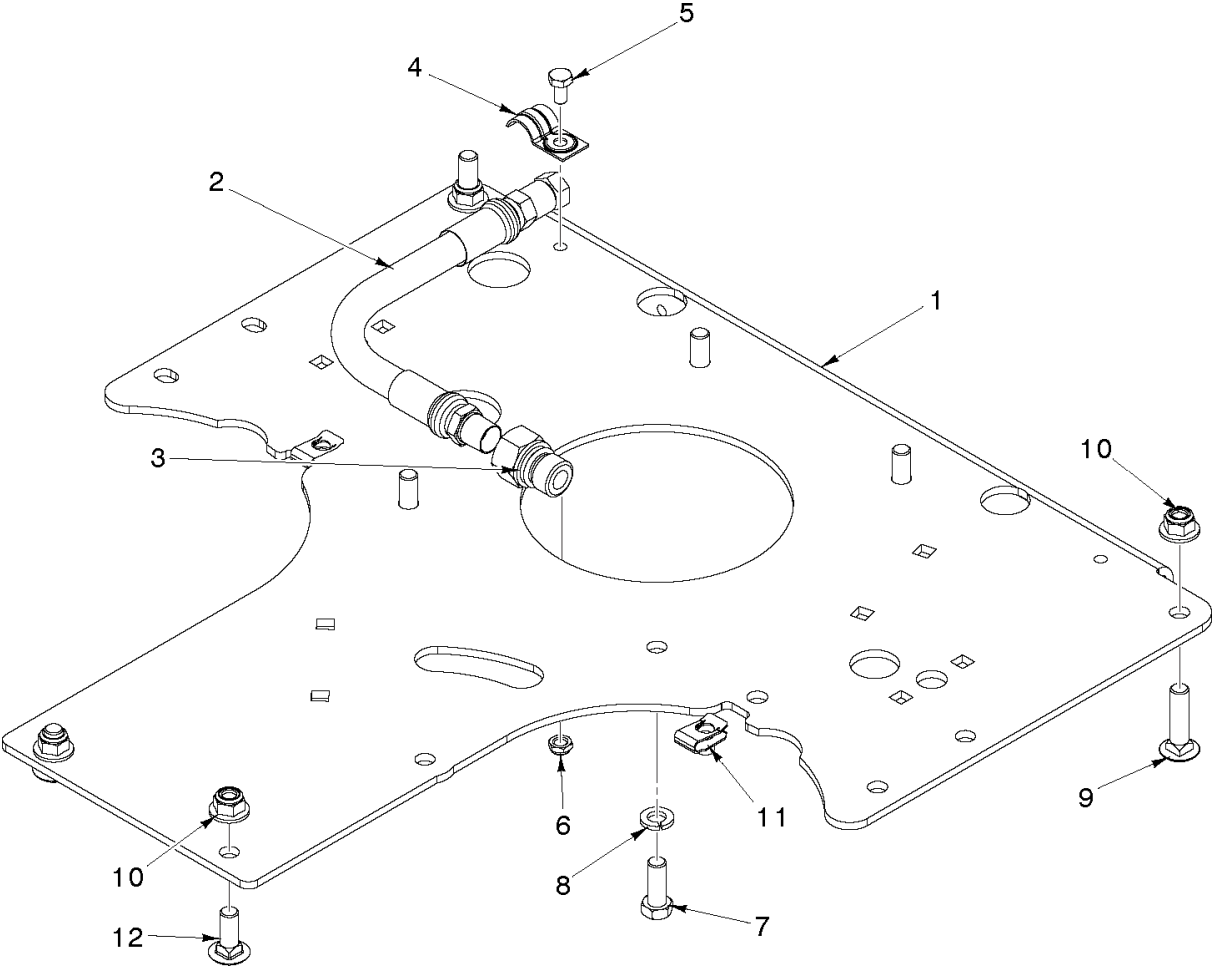

## ENGINE PLATE

Z454, 967984701-00, 2019-12

Ref	Part No	Description	Remark	QTY KIT
1	598 49 63-01	MODULE	KIT ENGINE PLATE WITH DECAL	1
2	584 82 55-01	HOSE ASSY	HOSE ASSY OIL DRAIN	1
3	522 59 90-02	ADAPTER	ADAPTER OIL DRAIN ADAPTER	1
4	539 10 13-63	CLAMP	CLAMP	1
5	596 43 70-01	SCREW	SCREW HEX HEAD 1/4- 20 X 1/2 IN	1
6	596 03 15-01	LOCK NUT	LOCK NUT HEX 0.188 x 0.218 IN	1
7	596 56 44-01	BOLT	BOLT HEX HEAD 3/8-16 X 1 IN	4
8	596 23 87-01	WASHER	LOCK WASHER .381 X .680 X 3/8	4
9	596 13 61-01	BOLT	BOLT SQUARE HEAD 3/8- 16 X 1-1/2	2
10	521 99 65-02	NUT	NUT HEX LOCK 3/8-16	4
11	539 10 47-63	CLIP	U-CLIP 5/16-18 NUT RETAINER	2
12	595 31 68-01	BOLT	BOLT 3/8-16 X 1 IN	2
	000 00 00-00	W/O DESCRIPTION	Kawasaki 22HP Engine FS651V-FS00-S	1

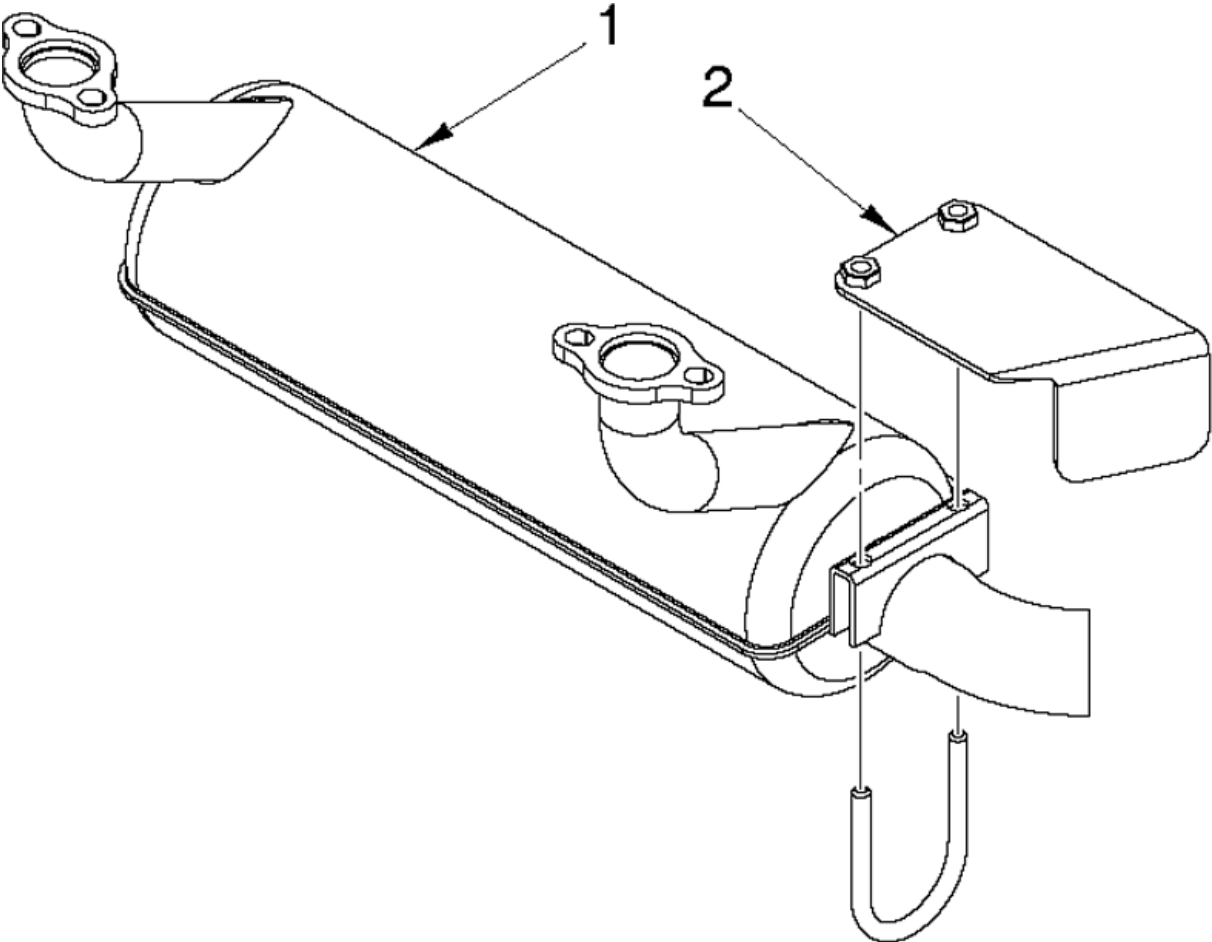

MUFFLER

Z454, 967984701-00, 2019-12

Ref	Part No	Description	Remark	QTY KIT
1	525 75 02-01	MUFFLER	MUFFLER	1
2	579 15 09-01	SHIELD	SHIELD MUFFLER	1

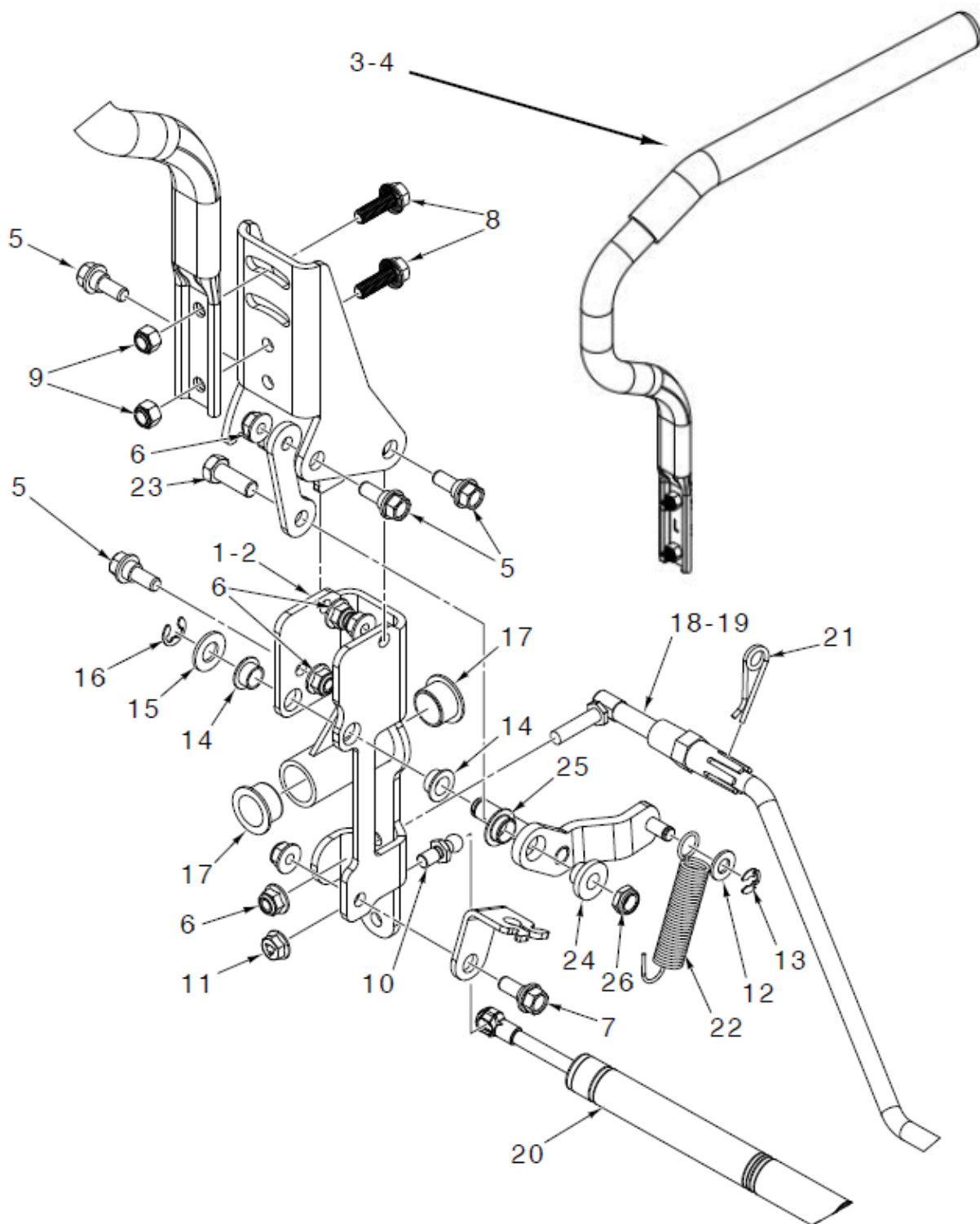



## STEERING - CONTROLS &amp; DAMPER

Z454, 967984701-00, 2019-12

Ref	Part No	Description	Remark	QTY KIT
1	598 48 64-02	SERVICE KIT	CONTROLS SYSTEM RH	1
2	598 48 64-01	SERVICE KIT	CONTROLS SYSTEM LH	1
3	596 98 53-04	LEVER	CONTROL LEVER RH	1
4	596 98 53-03	LEVER	CONTROL LEVER LH	1
5	597 00 13-01	BOLT	BOLT HEX HD 5/16 x 7/8	8
6	594 94 44-01	NUT	NUT 5/16-18	1
7	596 24 07-01	BOLT	BOLT HEX HD 5/16-18 x 5	1
8	597 00 11-01	BOLT	BOLT HEX HD 5/16 x 1	4
9	596 58 37-02	NUT	NUT 5/16-18 x 1	1
10	594 05 63-01	STUD	STUD	1
11	596 13 57-01	LOCK NUT	LOCK NUT 5/16-18	1
12	596 20 41-01	WASHER	WASHER	1
13	812 00 00-35	CLIP	CLIP	1
14	501 60 37-09	BEARING	BEARING FLANGED	4
15	597 00 12-01	WASHER	WASHER	1
16	522 70 52-01	RING	RING 7/16	1
17	539 13 15-18	BEARING. FLANGE	BEARING FLANGED	2
18	596 86 23-02	ROD	CONTROL ROD ASSEMBLY RH	1
19	596 86 23-01	ROD	CONTROL ROD ASSEMBLY LH	1
20	588 77 54-01	DAMPER	DAMPER	1
21	582 55 19-01	CLIP	RETAINING CLIP	1
22	597 90 68-01	SPRING	SPRING	1
23	596 56 44-01	BOLT	BOLT HEX HD 3/8-16 x 1	1
24	596 29 11-01	BUSHING	BUSHING	1
25	501 60 37-10	BEARING	BEARING FLANGED	1
26	596 23 08-01	NUT	NUT	1

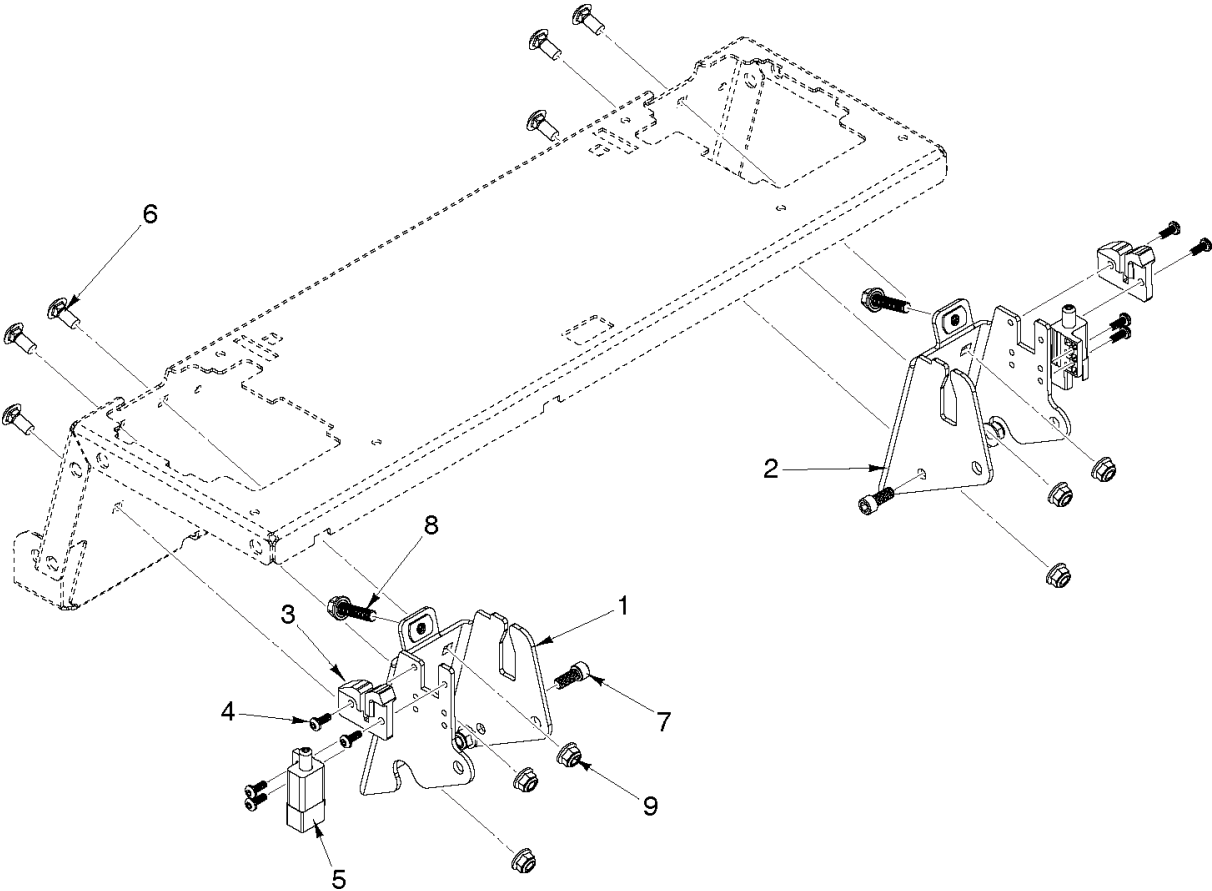

## STEERING - CONTROL BRACKET

Z454, 967984701-00, 2019-12

Ref	Part No	Description	Remark	QTY KIT
1	596 88 54-01	BRACKET	PIVOT BRACKET LH	1
2	596 88 54-02	BRACKET	PIVOT BRACKET RH	1
3	596 29 09-01	GUIDE	CONTROL GUIDE	1
4	597 85 62-01	SCREW	SCREW PAN HD 10-24	8
5	587 60 15-01	SWITCH	SWITCH INTERLOCK	1
6	595 90 16-01	BOLT	BOLT 5/16 x 3/4	1
7	596 91 71-01	SCREW	SCREW HEX HD 5/16-18 x 3/4	1
8	585 98 61-01	BOLT	BOLT 5/16-18 x 1-1/4	1
9	594 94 44-01	NUT	NUT 5/16-18	1

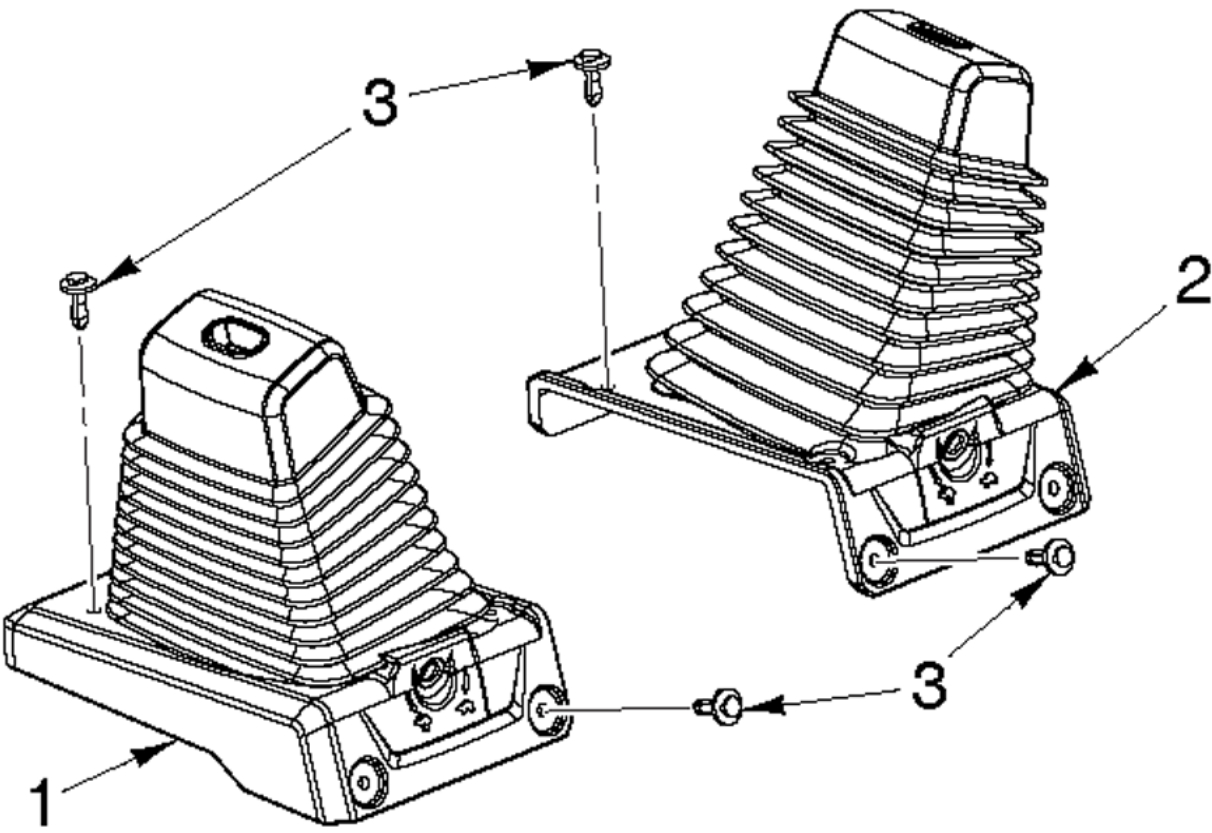

STEERING - BELLOWS

Z454, 967984701-00, 2019-12

Ref	Part No	Description	Remark	QTY KIT
1	596 24 68-01	BELLOWS	BELLOWS RH DRIVE LEVER	1
2	596 24 67-01	BELLOWS	BELLOWS LH DRIVE LEVER	1
3	582 48 29-01	RIVET	RIVET PUSH PIN 0.25IN HOLE	1

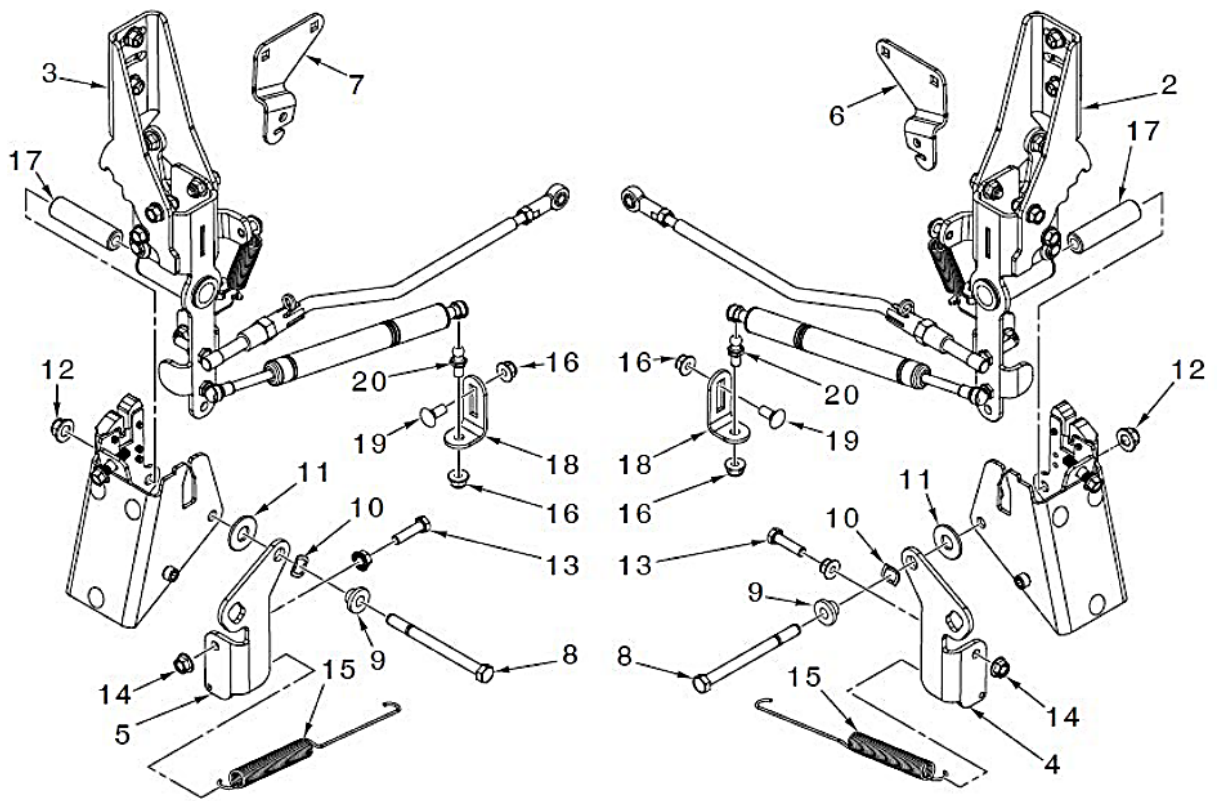

## STEERING - CONTROL MOUNT

Z454, 967984701-00, 2019-12

Ref	Part No	Description	Remark	QTY KIT
2	598 48 64-01	SERVICE KIT	CONTROLS SYSTEM LH	1
3	598 48 64-02	SERVICE KIT	CONTROLS SYSTEM RH	1
4	596 29 12-01	ARM	ARM RTN; CONTROLS; MZ LH	1
5	596 29 12-02	ARM	ARM RTN; CONTROLS; MZ RH	1
6	593 06 16-03	BRACKET	BRACKET CONTROLS LH	1
7	593 06 16-04	BRACKET	BRACKET CONTROLS RH	1
8	874 76 06-72	BOLT	"BOLT E 3/8-16UNC X 4,5 " Grade 2"	2
9	596 29 11-01	BUSHING	BUSHING RTN; CONTROLS; MZ	1
10	532 44 47-49	WASHER	WASHER	2
11	585 07 20-01	WASHER	WASHER	1
12	521 99 65-02	NUT	NUT HEXAGON LOCK 3/8-16	4
13	595 30 57-01	SCREW	SCREW 5/16-18UNC X 31	1
14	596 03 92-01	LOCK NUT	LOCK NUT 5/16-18 IN	1
15	593 10 67-01	SPRING	SPRING CONTROLS	1
16	594 94 44-01	NUT	NUT HEXAGON FLANGE 5/16-18 St	1
17	593 06 15-01	SPACER	SPACER CONTROLS	1
18	598 47 59-02	BRACKET	BRACKET DAMPER	2
19	595 90 16-01	BOLT	"BOLT 5/16-18UNC X 0,75 ""	1
20	594 05 63-01	STUD	STUD 10MM BALL	1

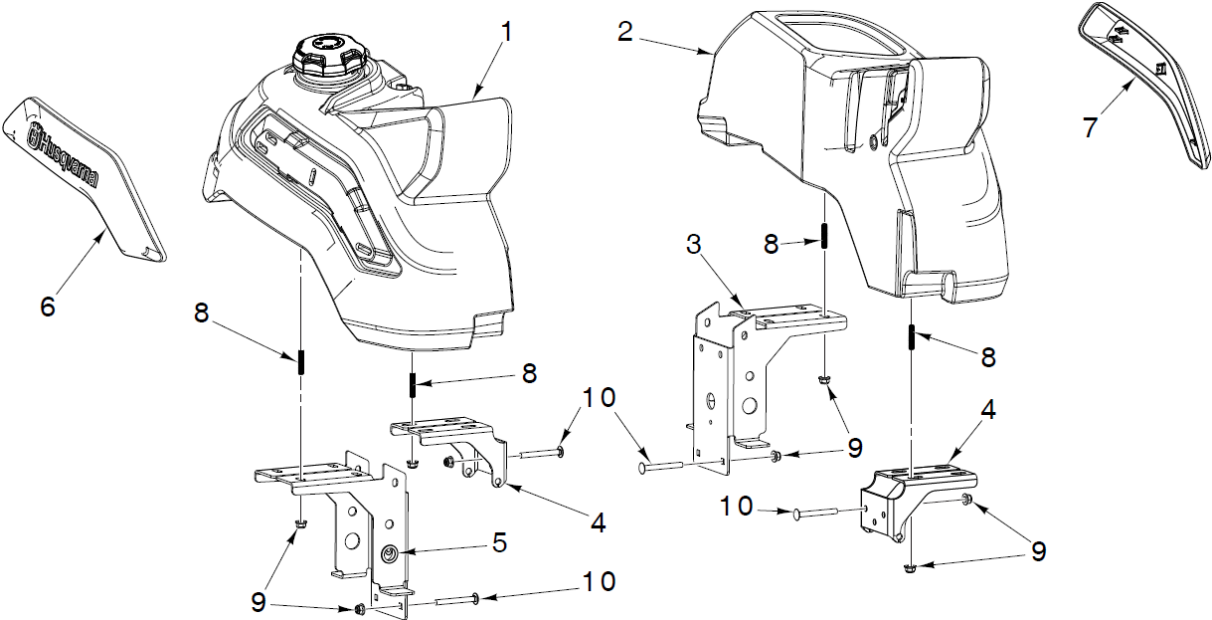



## FUEL TANK &amp; CONSOLE

Z454, 967984701-00, 2019-12

Ref	Part No	Description	Remark	QTY KIT
1	593 80 79-02	FUEL TANK ASSY	FUEL TANK ASSY Z300/Z400 RH	1
2	593 80 83-01	CONSOLE	CONSOLE Z300/Z400 LH	1
3	593 98 14-02	BRACKET	BRACKET FUEL TANK REAR	2
4	596 91 07-02	BRACKET	BRACKET FUEL TANK FRONT	2
5	596 77 39-01	BUSHING	BUSHING SNAP	1
6	582 48 24-01	COVER	COVER RH FUEL TANK	1
7	582 48 34-01	COVER	COVER LH FUEL TANK	1
8	582 48 42-01	SCREW	SCREW 5/16-18 X 1.5IN	1
9	594 94 44-01	NUT	NUT HEXAGON FLANGE 5/16-18	1
10	872 11 05-22	BOLT	BOLT 5/16-18 X 2.75	12

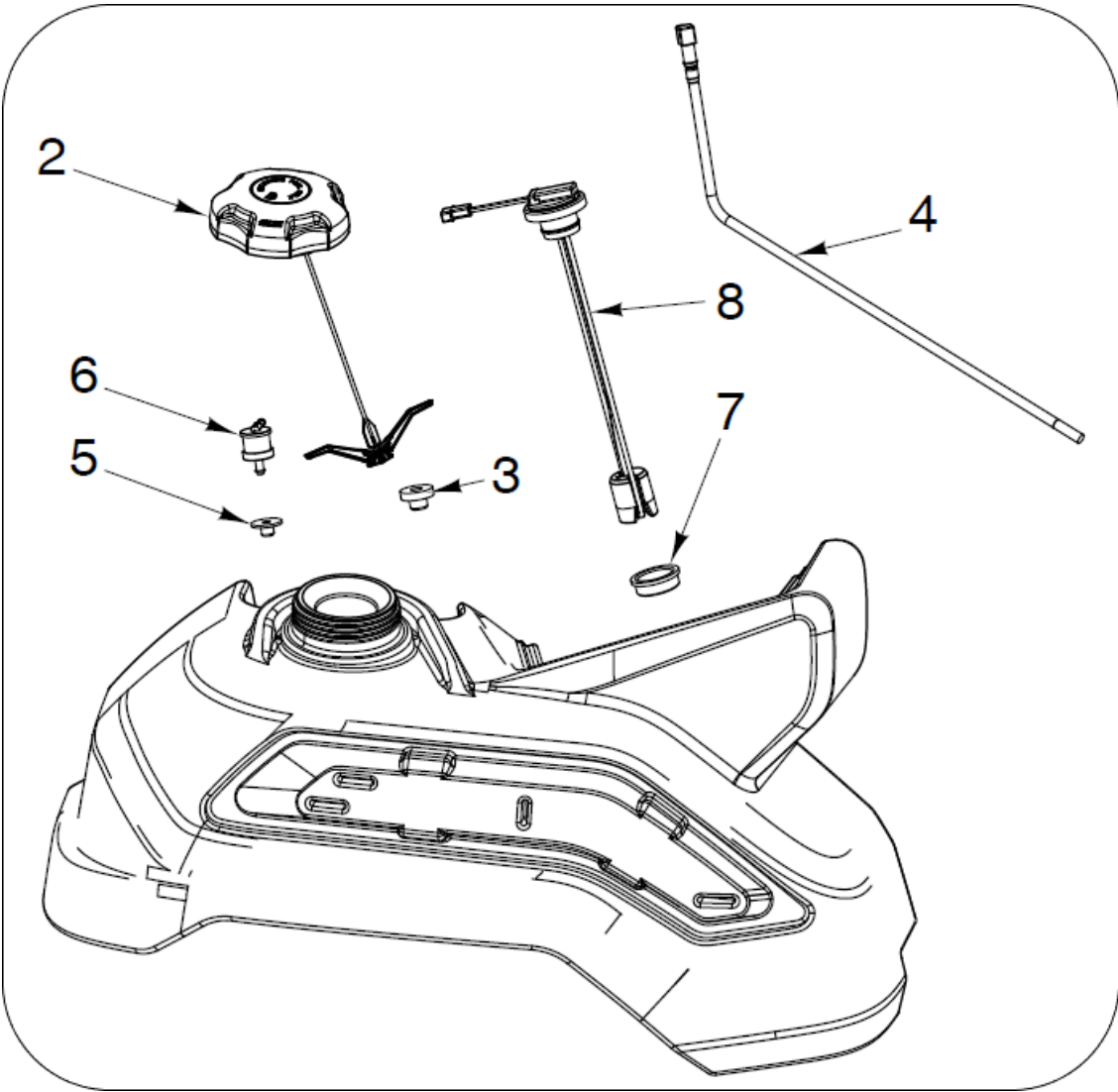

## FUEL TANK PARTS

Z454, 967984701-00, 2019-12

Ref	Part No	Description	Remark	QTY KIT
1	593 80 79-02	FUEL TANK ASSY	FUEL TANK RH	1
2	575 01 81-03	CAP	FUEL CAP	1
3	532 00 36-45	BUSHING	GROMMET	1
4	525 86 54-03	TUBE ASSY	FUEL TANK PICK-UP TUBE	1
5	584 64 82-01	GROMMET	GROMMET	1
6	576 61 81-01	TANK VENT	ROLL OVER VALVE	1
7	590 20 91-01	GROMMET	GROMMET	1
8	593 64 44-01	SENSOR	FLOAT FUEL LEVEL SENSOR	1

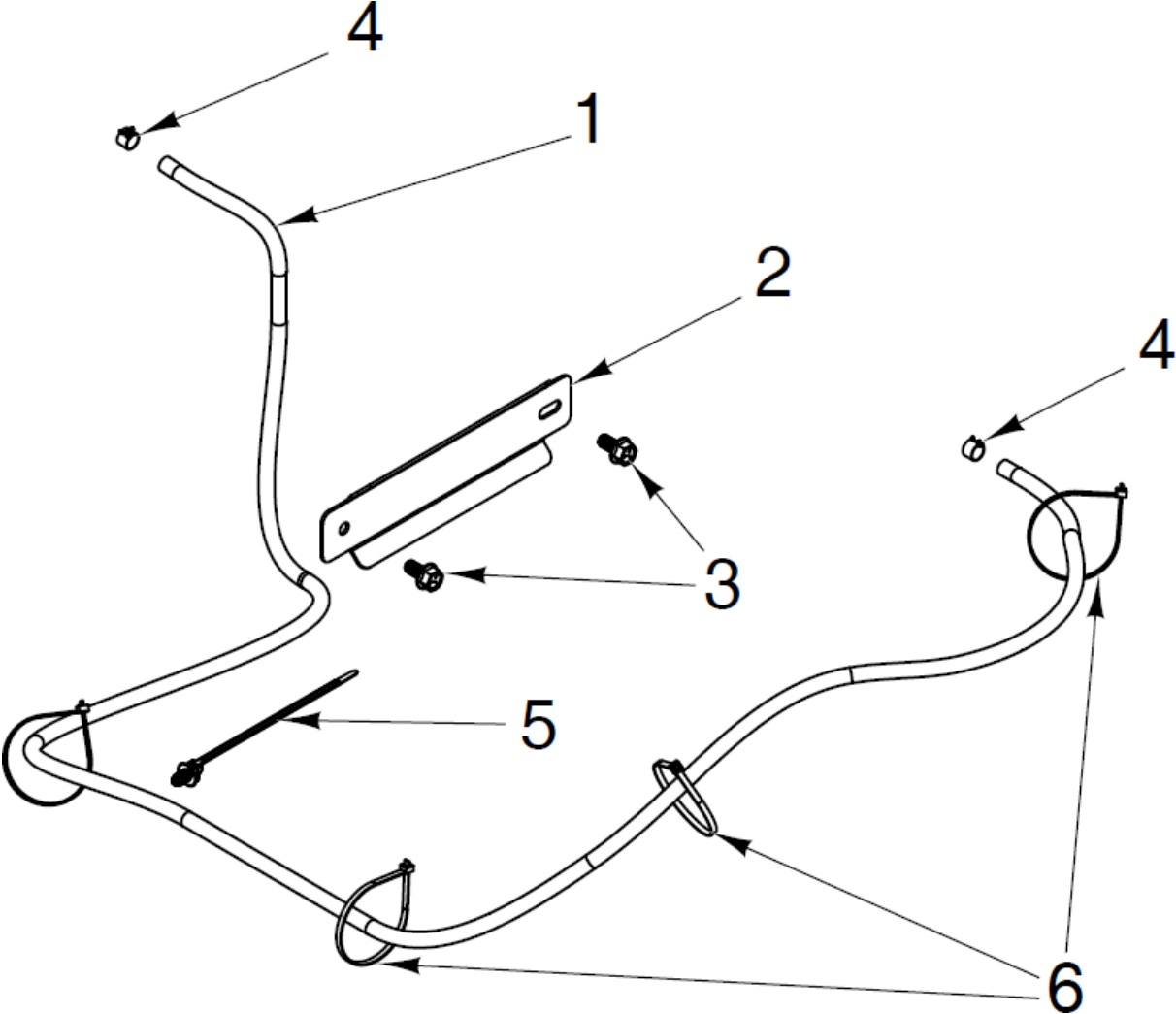

## FUEL SYSTEM - VAPOR LINE

Z454, 967984701-00, 2019-12

Ref	Part No	Description	Remark	QTY KIT
1	587 04 45-69	HOSE	"HOSE 3/16"" VAPOR LINE 69""	1
2	593 93 82-02	PLATE	PLATE HOSE RETENTION)	1
3	596 58 46-01	SCREW	SCREW 5/16-18 X 0.625 HEX FLANGE W/ LOCTITE	1
4	575 43 65-01	CLAMP	CLAMP HOSE	1
5	591 36 71-01	CABLE	"CABLE, 1/4 INCH HOLE, BLK 6 INCH"	1
6	539 97 68-56	TIE WRAP	TIE WRAP	1

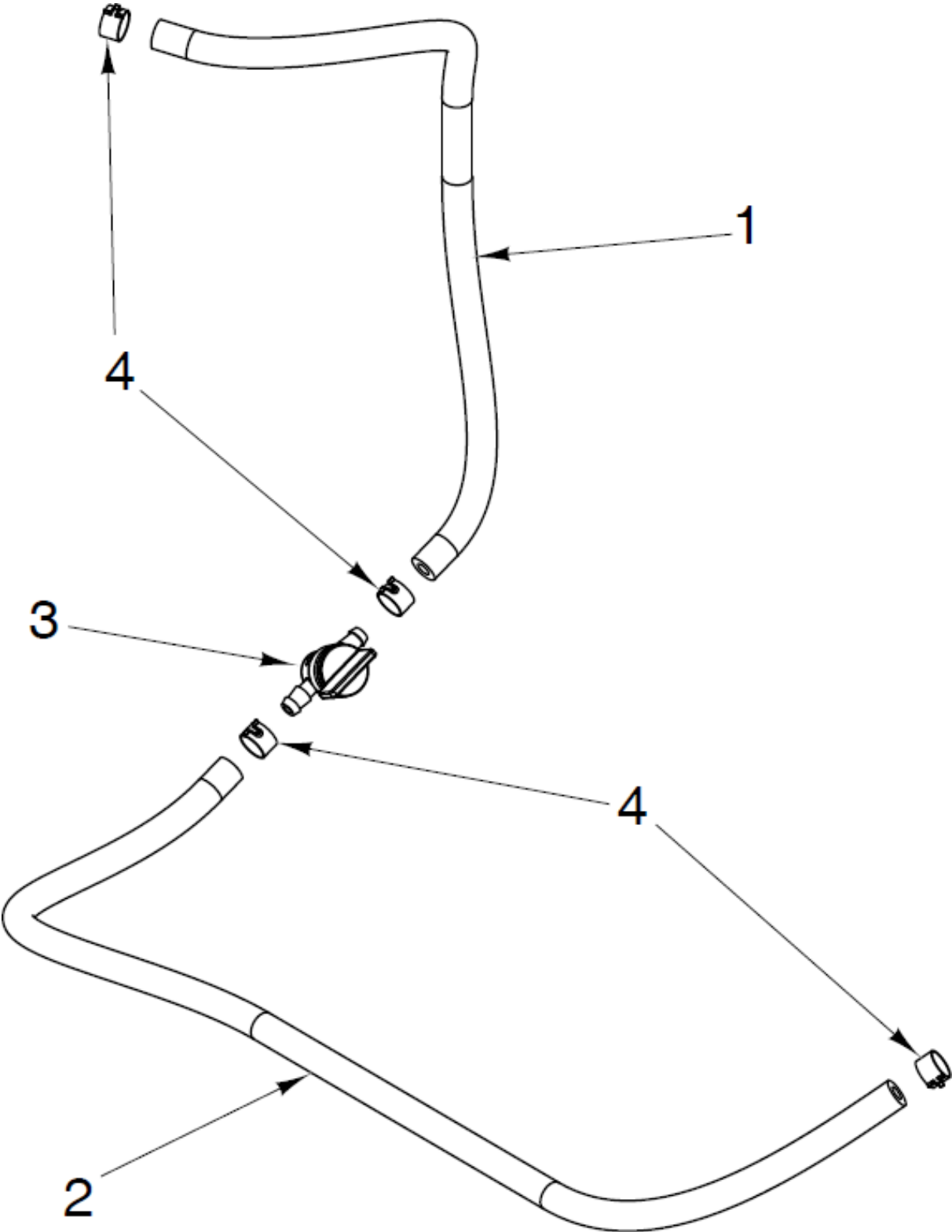

## FUEL LINE &amp; VALVE

Z454, 967984701-00, 2019-12

Ref	Part No	Description	Remark	QTY KIT
1	587 04 48-18	HOSE	"HOSE 1/4" FUEL LINE 18"	1
2	587 04 48-23	HOSE	"HOSE 1/4" FUEL LINE 23" LENGTH"	1
3	539 91 63-25	FUEL VALVE	FUEL VALVE	1
4	539 91 22-22	CLAMP	HOSE CLAMP	1

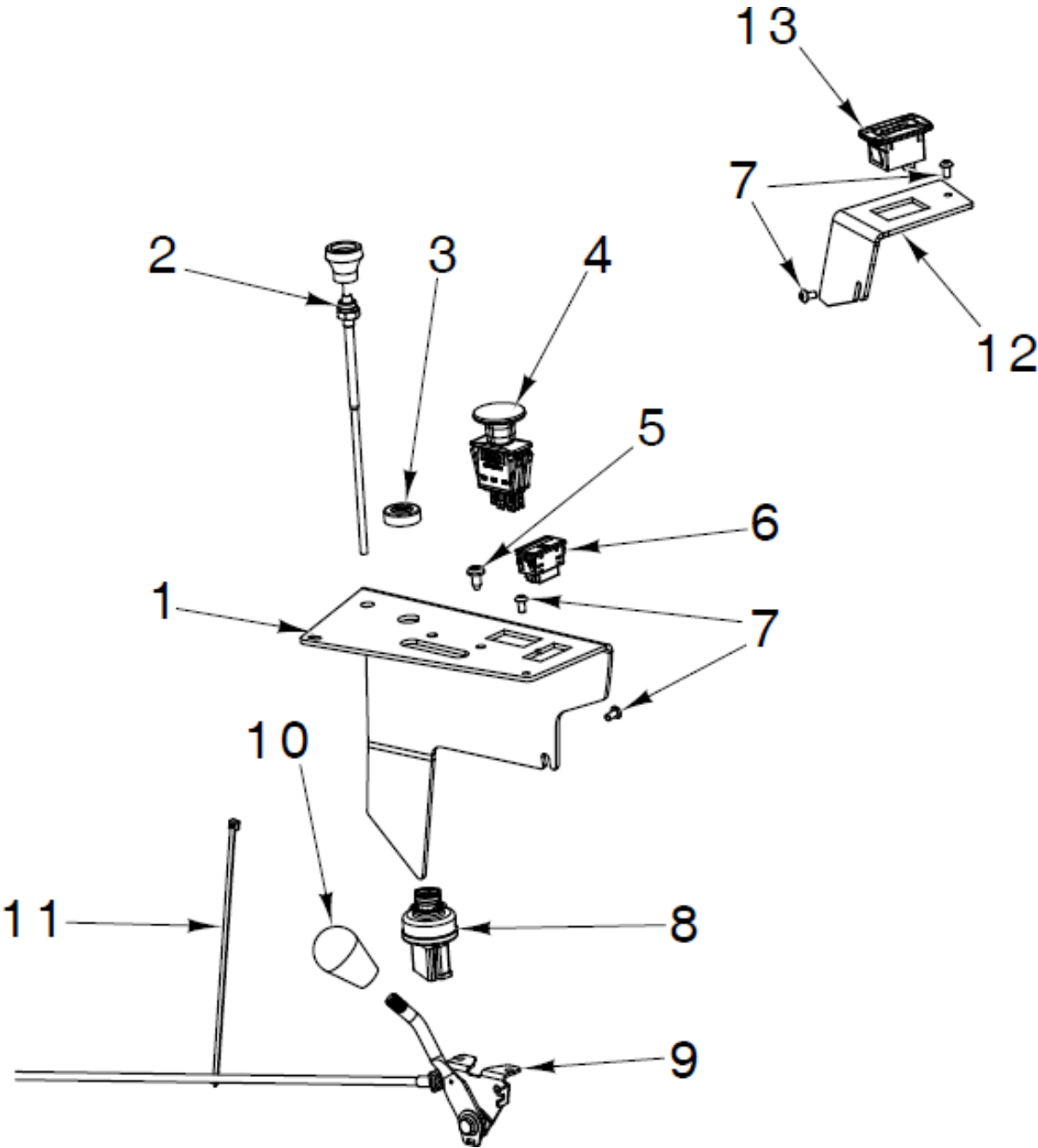



## CONTROL PANEL

Z454, 967984701-00, 2019-12

Ref	Part No	Description	Remark	QTY KIT
1	593 98 24-02	CONTROL PANEL	CONTROL PANEL	1
2	574 20 69-07	CABLE	CABLE CHOKE T	1
3	539 10 31-78	NUT CAP	NUT CAP COVER	1
4	589 88 72-01	SWITCH	"SWITCH PTO, 10 AMP,"	1
5	532 19 98-55	SCREW	SCREW 1/4-20 X 1/2 IN PAN HEAD	2
6	592 87 27-03	FUEL GAUGE	"FUEL GAUGE LED, SMALL LOW"	1
7	539 11 43-41	SCREW	SCREW #10-24 X 3/8 SOCKET HEAD	5
8	574 45 54-01	SWITCH	SWITCH IGNITION	1
9	597 52 39-06	THROTTLE	THROTTLE MZ/PZ	1
10	539 13 26-24	KNOB - SHIFT	SHIFT KNOB	1
11	539 97 68-56	TIE WRAP	TIE WRAP	1
12	593 98 16-02	CONTROL PANEL	CONTROL PANEL LH	1
13	594 91 91-01	HOUR METER	HOUR METER	1
	595 84 06-03	HARNESS	NOT SHOWN	1

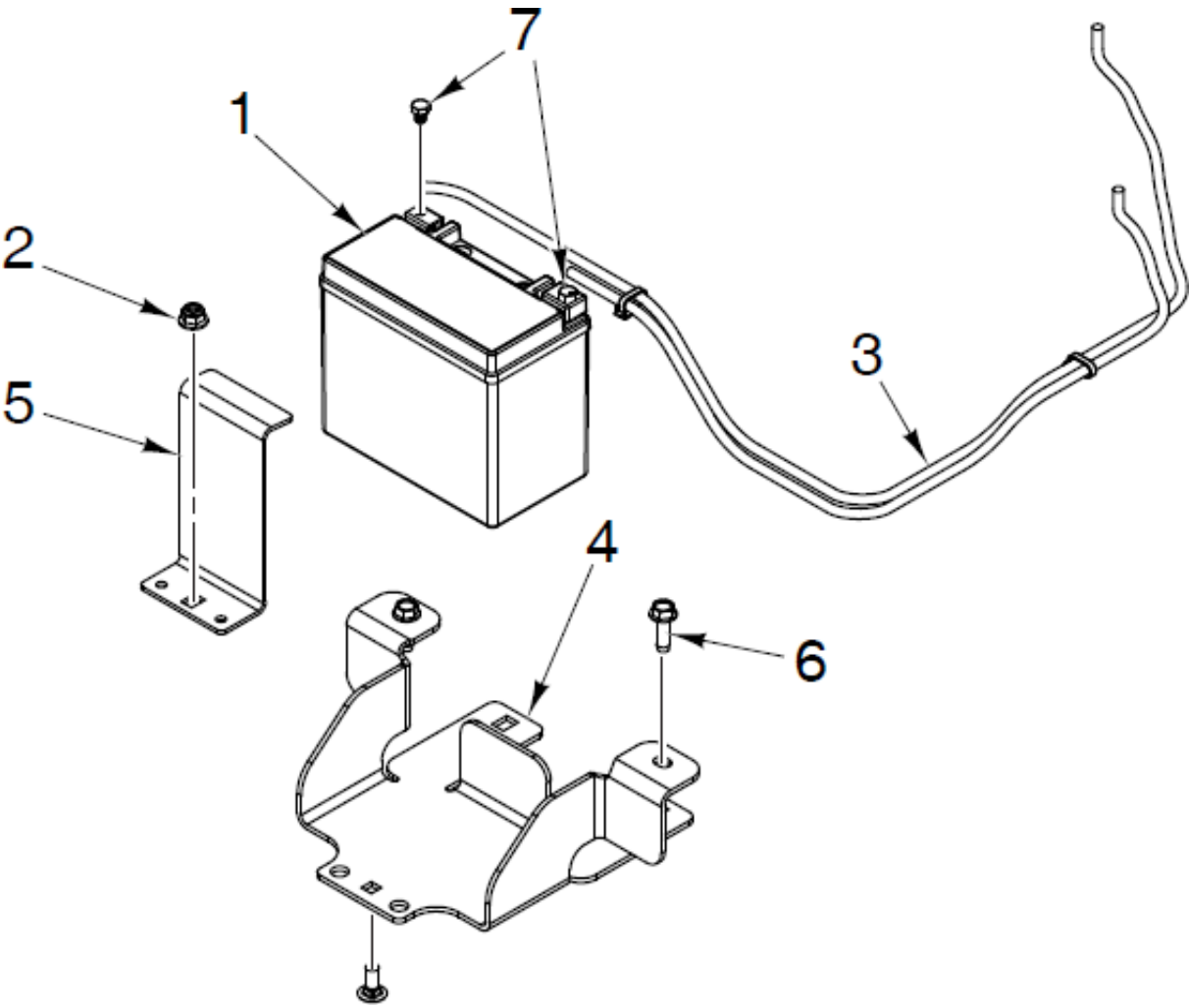

## BATTERY

Z454, 967984701-00, 2019-12

Ref	Part No	Description	Remark	QTY KIT
1	589 81 95-02	BATTERY	"BATTERY STARTER 10AH,180CCA"	1
2	594 94 44-01	NUT	NUT HEXAGON FLANGE 5/16-18	1
3	590 63 21-02	CABLE	"CABLE BATTERY ASSY, 6GA"	1
4	595 31 36-02	BRACKET	BRACKET BATTERY BLACK	1
5	595 31 35-04	BRACKET	BRACKET BATTERY MOUNT	1
6	596 43 38-01	SCREW	SCREW HEX HEAD 5/16- 18 X 1 IN	2
7	582 46 08-02	SCREW	SCREW M6 x 8MM HEX CAP	1

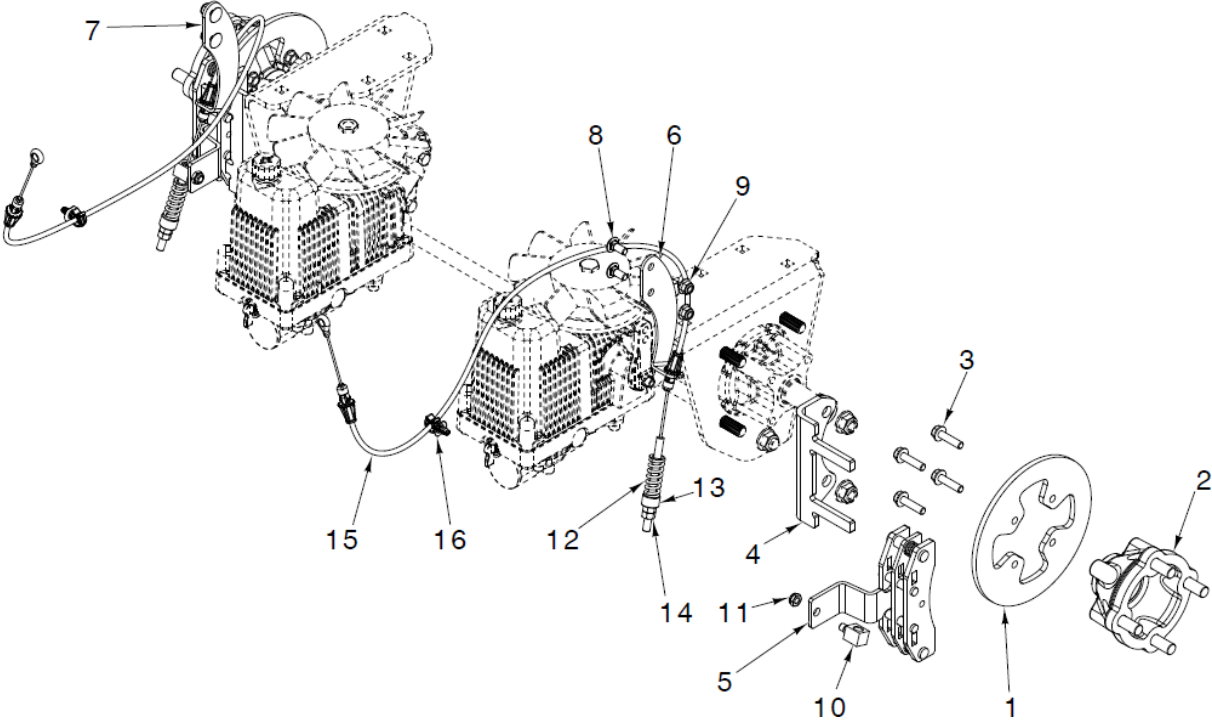

## BRAKE

Z454, 967984701-00, 2019-12

Ref	Part No	Description	Remark	QTY KIT
1	597 53 72-01	ROTOR	ROTOR BRAKE	2
2	595 96 77-02	HUB	HUB CASTING W/ STUDS	1
3	525 54 40-02	BOLT	"BOLT 5/16-18UNC X 1,25 " Grade 5"	1
4	597 53 70-01	BRACKET	"BRACKET MTG, CALIPER HTE10"	2
5	597 53 69-01	CALIPER	"CALIPER BRAKE, PARK"	2
6	597 53 71-01	BRACKET	"BRACKET, CABLE, BRAKE LH"	1
7	597 53 71-02	BRACKET	"BRACKET, CABLE, BRAKE RH"	1
8	595 90 16-01	BOLT	"BOLT 5/16-18UNC X 0,75 " Grade 5"	1
9	594 94 44-01	NUT	NUT HEXAGON FLANGE 5/16-18	1
10	525 85 14-02	SWIVEL	SWIVEL BRAKE CLEAR ZINC	2
11	596 43 36-01	NUT	NUT 5/16-18 INSERT 5/16-18 X 1/4	1
12	597 82 69-01	SPRING	SPRING 2.00L X .50ID; 150LB_IN	1
13	539 92 35-15	SPACER	SPACER	1
14	596 04 09-01	HEXAGON NUT	HEX NUT 5/16-24 IN GRF	1
15	597 77 35-01	CABLE	"CABLE BRAKE, PARKING DISC"	2
16	592 85 74-01	CLIP	"CLIP CABLE, 1/4 BLACK FIR TREE"	1

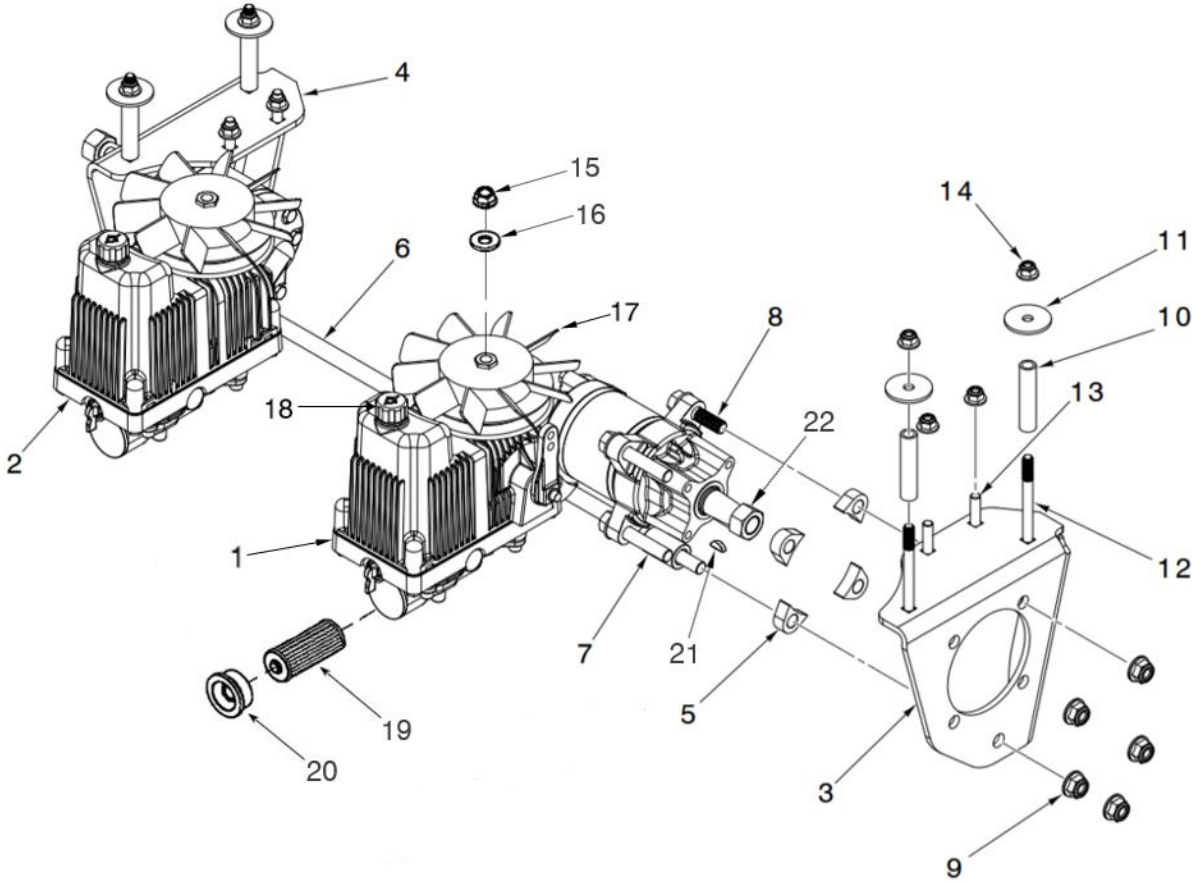

## TRANSMISSION

Z454, 967984701-00, 2019-12

Ref	Part No	Description	Remark	QTY KIT
1	594 09 03-01	TRANSMISSION	10CC PUMP	1
2	594 09 03-02	TRANSMISSION	10CC PUMP	1
3	596 69 19-03	BRACKET	"BRACKET MTG, XMSN LH, BLK"	1
4	596 69 19-04	BRACKET	"BRACKET MTG, XMSN RH, BLK"	1
5	596 69 25-01	SPACER		1
6	594 09 11-01	CROSSBAR	SPACER TRANSMISSION	1
7	582 53 95-02	BOLT		1
8	597 00 20-01	SCREW		8
9	521 99 11-02	NUT	"BOLT FLANGE , 1/2-13 X 2.75 GRD 5"	8
10	594 09 08-01	SPACER	"SCREW HHFS 1/2-13, 2 IN"	4
11	596 91 73-01	WASHER		1
12	525 84 86-01	RHSNB	RHSNB 3/8-16 x 4	4
13	596 13 61-01	BOLT	"BOLT 3/8-16UNC X 1,5 " Grade 5 ZPB"	4
14	521 99 65-02	NUT	NUT HEX LOCK FLANGE 3/8-16	4
15	599 37 15-01	RETAINER		1
16	599 37 14-01	RETAINER		1
17	599 37 13-01	FAN		1
18	596 48 79-01	DIPSTICK		1
19	599 37 01-01	FILTER		1
20	599 37 02-01	CAP ASSY		1
21	599 37 12-01	KEY		1
22	599 37 03-01	AXLE	Nut	1

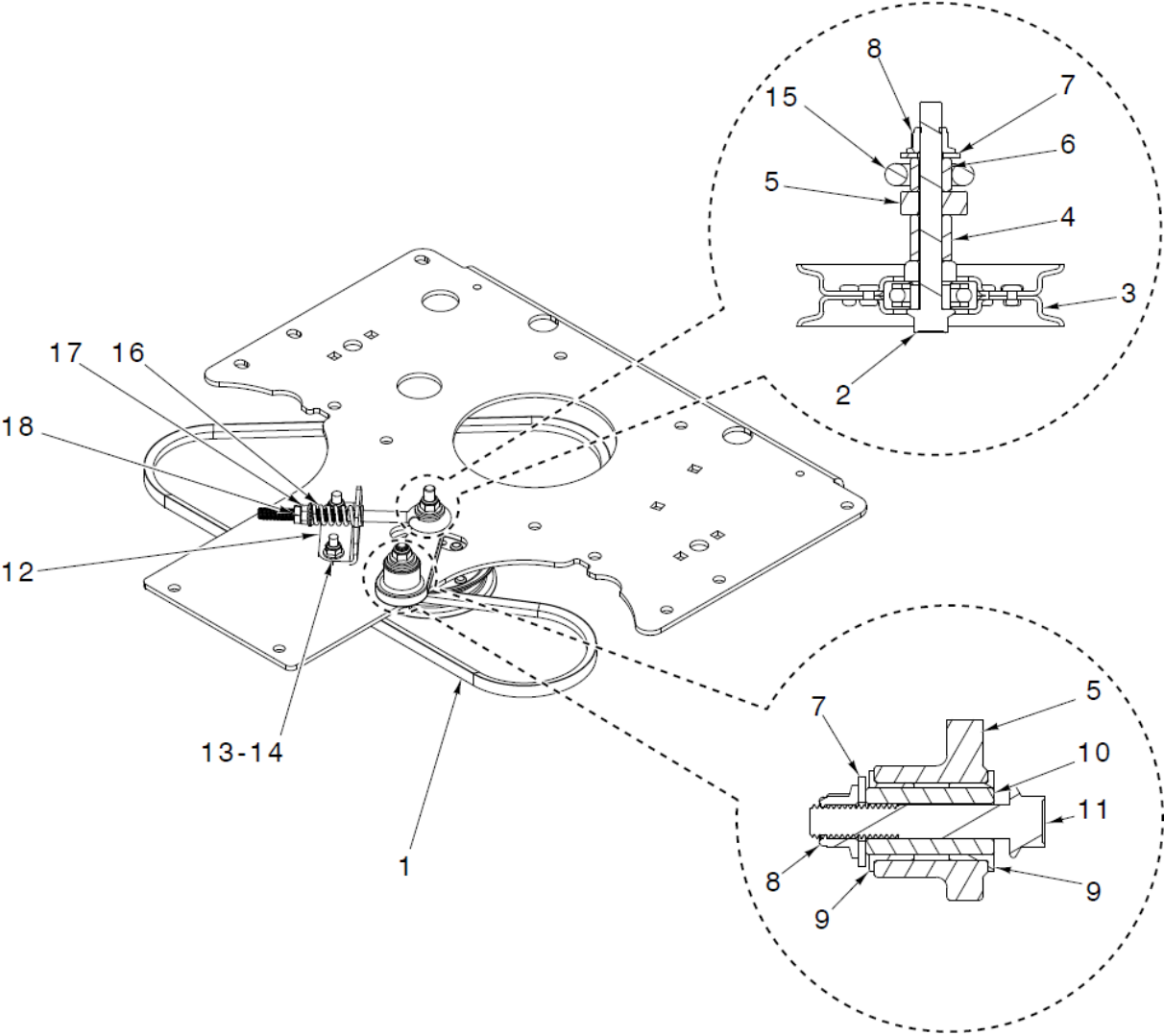



## DRIVE

Z454, 967984701-00, 2019-12

Ref	Part No	Description	Remark	QTY KIT
1	594 09 88-01	BELT	"BELT GROUND DRIVE, HA 60.75"	1
2	525 82 21-01	BOLT	BOLT 3/8-16 X 3.5 HHFS GD 5	1
3	596 48 14-01	PULLEY	PULLEY PULLEY.IDLER.FLAT.3.	1
4	594 09 99-02	SPACER	SPACER HG .781	1
5	594 09 91-01	ARM	ARM IDLER Z400_300	1
6	594 09 99-01	SPACER	SPACER PRKR .557	1
7	596 43 37-01	WASHER	WASHER 3/8 FLAT STD ZD 0.453 X 1.030 X 0.104 IN ST	1
8	521 99 65-02	NUT	NUT HEX LOCK FLANGE 3/8-16 St	4
9	501 60 37-01	BEARING	"BEARING FLANGED 3/4""ID X 1/2""L"	2
10	594 10 02-01	SPACER	"SPACER PIVOT, TENSION ARM"	1
11	577 09 83-01	HHFS	HHFS 3/8-16 X 2.25 GD 8	1
12	594 10 03-01	BRACKET	"BRACKET ANCHOR, TENSIONER"	1
13	595 90 15-01	BOLT	BOLT CUP HEAD 5/16-18 x 1.02 IN	1
14	594 94 44-01	NUT	NUT HEX FLANGE 5/16- 18 St ZPB	1
15	594 10 04-01	LINKAGE	LINKAGE TENSIONER	1
16	532 15 13-32	SPRING	SPRING	1
17	596 58 35-01	WASHER	WASHER HEX LOCK NUT WITH FLANGE 3/8-16 X 0.765 IN ST	1
18	596 43 35-01	NUT	NUT 3/8-16 HEX JAM 3/8- 16 X .562 IN	1

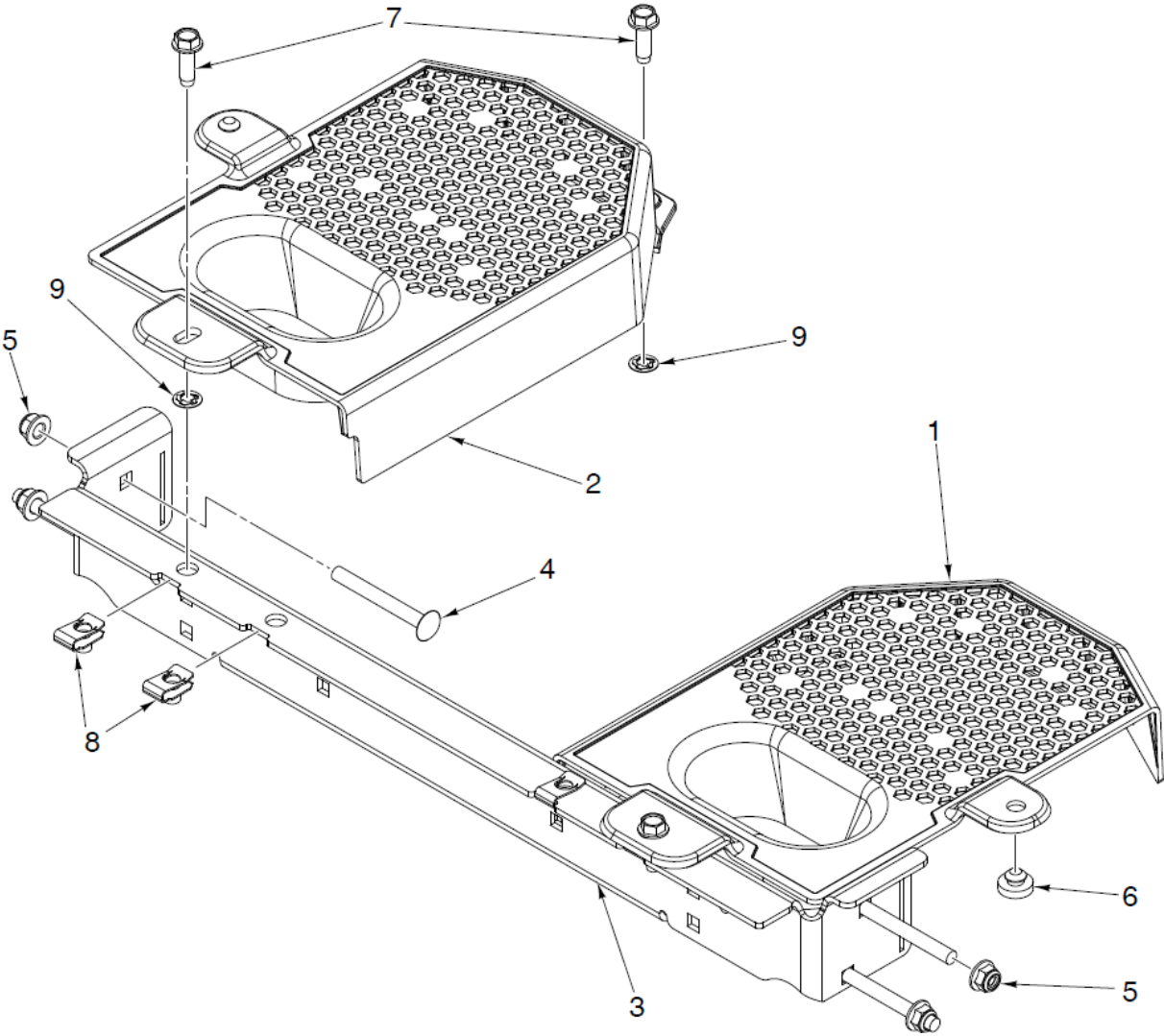

## CROSS MEMBER &amp; FAN COVERS

Z454, 967984701-00, 2019-12

Ref	Part No	Description	Remark	QTY KIT
1	598 46 84-02	MODULE	KIT LH FAN SHIELD	1
2	598 46 84-01	MODULE	KIT RH FAN SHIELD	1
3	596 97 27-02	BRACKET	CROSS MEMBER	1
4	874 49 05-48	BOLT	BOLT HEX 5/16-18X3	4
5	594 94 44-01	NUT	NUT HEXAGON FLANGE 5/16-18	4
6	539 10 25-87	ABSORBER	ABSORBER VIBRATION GROMMET	2
7	596 43 38-01	SCREW	BOLT HHFS 5/16-18 X 1	4
8	539 10 47-63	CLIP	U-CLIP 5/16-18 NUT RETAINER	4
9	532 42 30-63	WASHER	"WASHER 5/16""	4

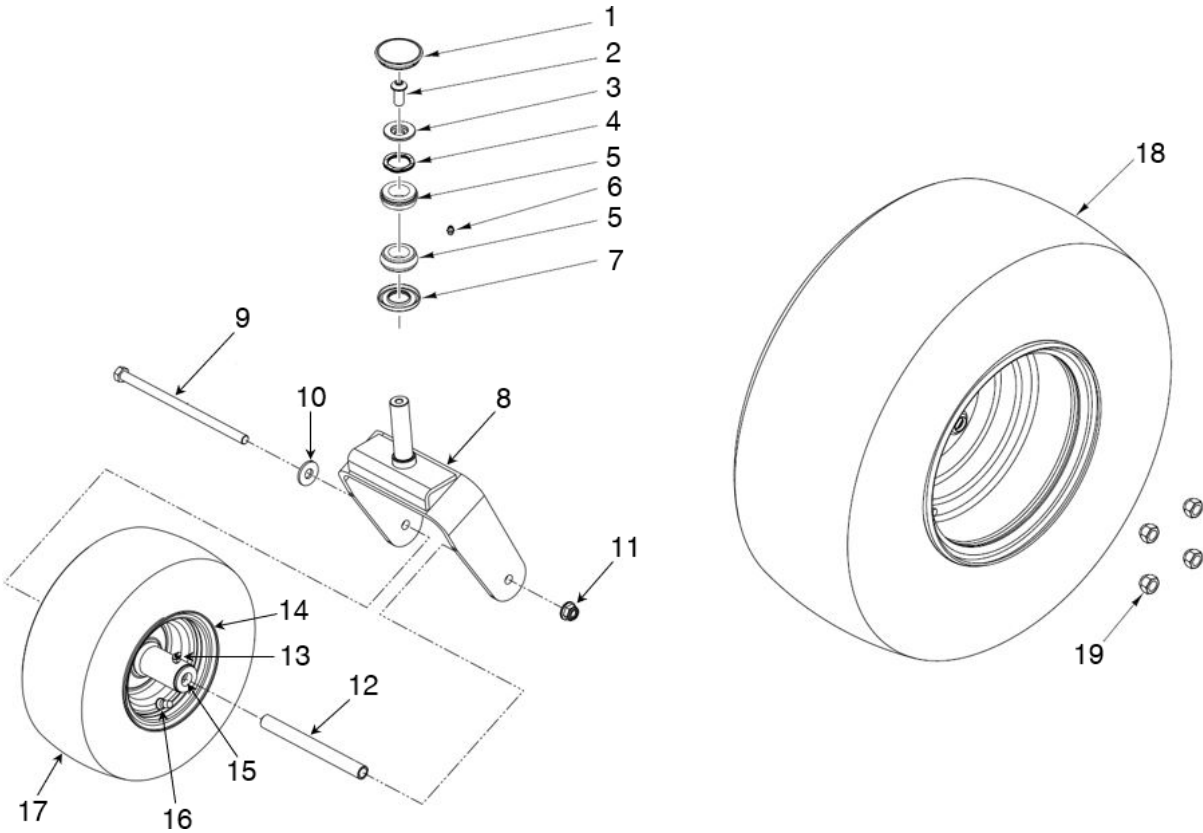

## WHEELS &amp; TIRES

Z454, 967984701-00, 2019-12

Ref	Part No	Description	Remark	QTY KIT
1	590 70 00-01	CAP	CAP DUST YELLOW ZINC	2
2	591 45 73-01	SCREW	SCREW Torx 7/16-14UNC X 1 "	2
3	591 42 51-01	CAP	CAP SPRING. MZ/MZT CASTER RAW	2
4	590 68 16-01	SPRING	SPRING NESTED WAVE	2
5	539 10 25-43	BEARING	BEARING TAPER ROLLER CONE	4
6	539 10 14-74	NIPPLE	NIPPLE ZERK	2
7	539 10 28-51	SEALING	SEAL	2
8	590 67 46-02	FORK		2
9	539 10 55-17	BOLT		2
10	819 18 22-12	WASHER		2
11	521 99 11-01	NUT		2
12	575 33 49-01	SPACER		2
13	539 10 33-00	NIPPLE		2
14	581 19 95-01	WHEEL ASSY	FRONT	2
15	539 10 24-84	BEARING		4
15	539 10 53-07	ROLLER BEARING		4
16	539 91 22-34	VALVE		4
17	539 10 55-22	TIRE	FRONT	2
18	580 74 70-01	TIRE	REAR	2
19	587 65 39-02	NUT		8
	582 74 63-01	TIRE	REAR	2

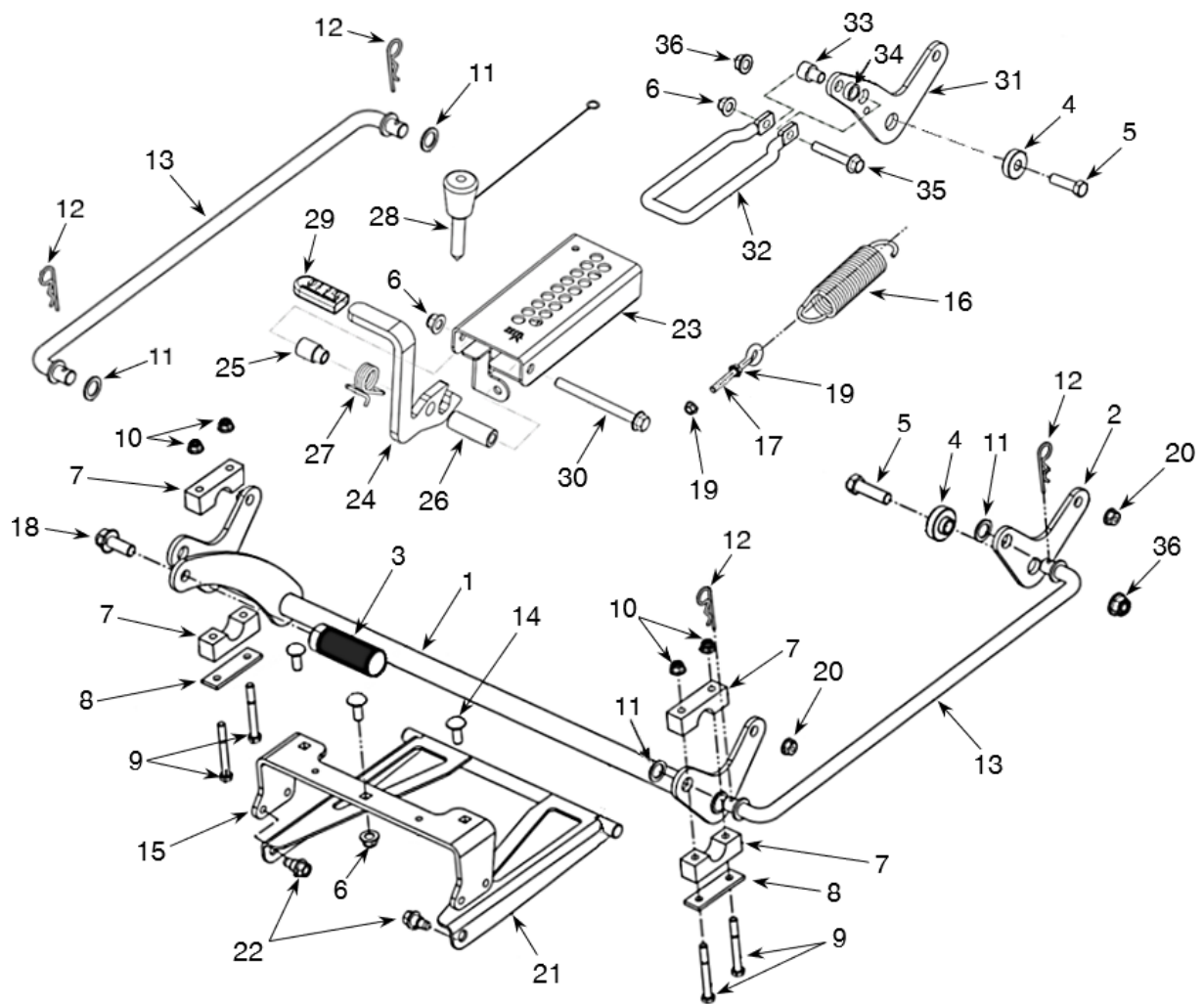

## MOWER LIFT / DECK LIFT

Z454, 967984701-00, 2019-12

Ref	Part No	Description	Remark	QTY KIT
1	592 80 90-02	SHAFT	"SHAFT DECK LIFT, WELDMENT"	1
2	593 07 77-04	ARM	"ARM BELL CRANK, REAR LH"	1
3	510 40 83-02	PEDAL	PEDAL DECK HEIGHT	1
4	586 70 17-02	SPACER	SPACER IDLER METAL POWDER	2
5	596 43 58-01	BOLT	"BOLT E 1/2-13UNC X 1,75 ""	2
6	521 99 65-02	NUT	NUT HEXAGON LOCK 3/8-16	3
7	539 10 48-08	SUPPORT	SUPPORT PILLOW BLOCK	4
8	584 39 27-02	PLATE	PLATE REINFORCEMENT	2
9	596 21 86-01	BOLT	"BOLT 5/16-18UNC X 2,75 " Grade 5"	4
10	594 94 44-01	NUT	NUT HEXAGON FLANGE 5/16-18	4
11	596 93 34-01	WASHER	WASHER PLAIN 21/32 X 1 X 16GA IN	4
12	596 27 31-01	PIN	PIN HAIRPIN COTTER #4	4
13	591 06 69-01	ROD	ROD BELL CRANK CONNECTOR	2
14	595 31 68-01	BOLT	BOLT 3/8-16UNC X 1 " Grade 5	3
15	582 51 94-02	BRACKET	BRACKET DECK DRAWBAR MOUNT	1
16	596 84 80-01	SPRING	SPRING EXTENSION	1
17	596 24 08-01	BOLT	BOLT EYELET BOLT 5/16-18 X 3-1/2	1
18	593 90 34-01	BOLT	"BOLT 1/2-13UNC X 1,25 ""	1
19	596 03 92-01	LOCK NUT	LOCK NUT HEX 5/16-18 IN	2
20	873 90 06-00	NUT	NUT LOCK FLG 3/8-16	4
21	591 06 74-02	DRAWBAR		1
22	532 19 65-39	BOLT		1
23	590 93 43-02	HEIGHT ADJUSTER		1
24	589 45 42-01	LEVER		1
25	594 03 73-01	PIVOT		1
26	510 40 84-02	SPACER		1
27	590 93 75-01	SPRING		1
28	592 91 42-03	PIN		1
29	539 13 28-51	GRIP. TRANSPORT-RELEASE		1
30	521 99 66-02	SCREW		1
31	593 07 77-03	ARM		1
32	590 93 47-01	LINK ROD		1
33	594 03 72-01	PIVOT		1
34	596 51 52-01	SPACER		1
35	596 43 83-01	BOLT		1
36	521 99 11-02	NUT		1

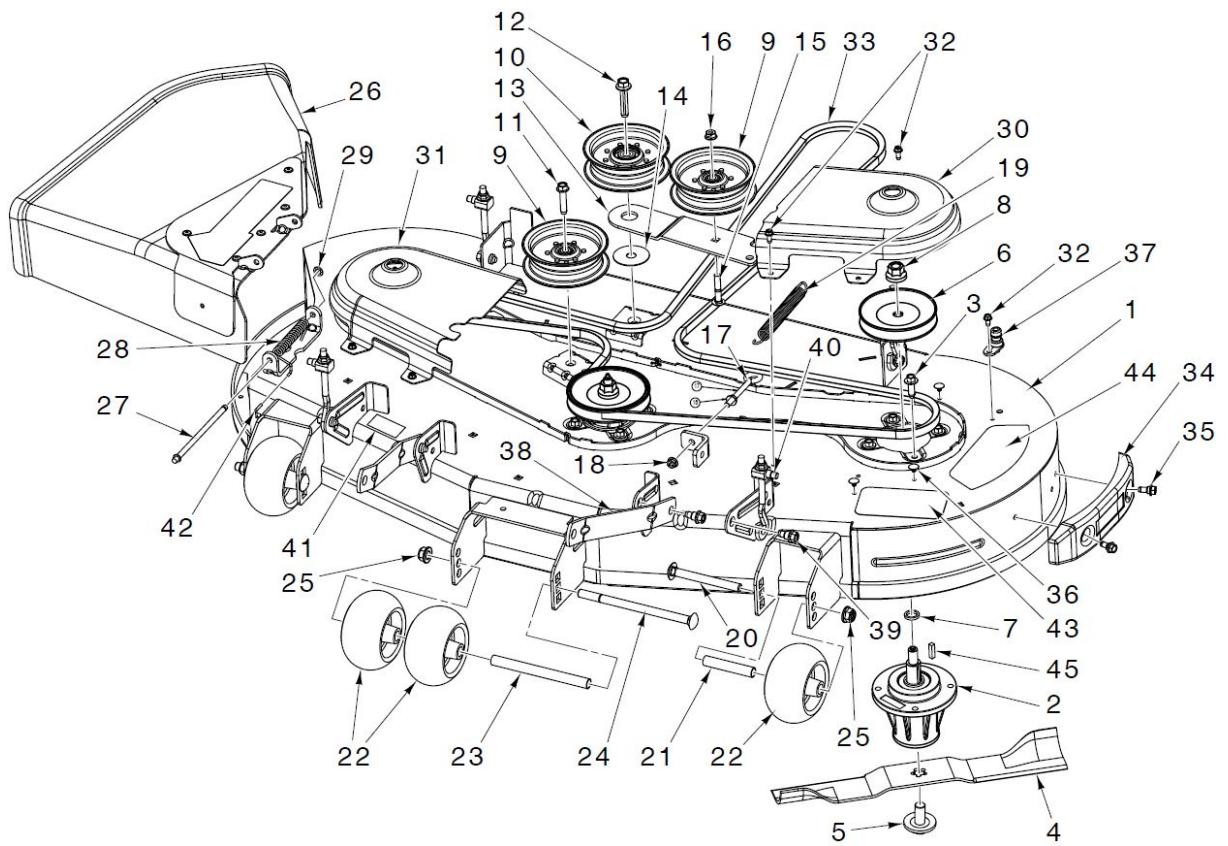



## MOWING DECK

Z454, 967984701-00, 2019-12

Ref	Part No	Description	Remark	QTY KIT
1	591 12 01-01	SERVICE KIT		1
2	596 79 45-02	MANDREL		3
3	584 95 39-01	BOLT		12
4	582 06 25-02	BLADE		3
5	539 11 90-07	SCREW		3
6	590 80 51-04	PULLEY		3
7	532 18 76-90	WASHER		3
8	539 13 06-53	NUT - FLANGE 3/4-16		3
9	532 19 61-06	PULLEY		2
10	532 19 61-04	PULLEY		1
11	596 56 40-03	BOLT		1
12	588 43 83-01	SCREW		1
13	582 21 96-02	ARM		1
14	532 17 85-15	WASHER		1
15	596 13 63-01	BOLT		1
16	873 90 06-00	NUT		1
17	596 24 08-01	BOLT		1
18	596 03 92-01	LOCK NUT		1
19	532 19 72-51	SPRING		1
20	510 02 23-02	SCREW		2
21	574 19 64-02	TUBE		2
22	574 16 96-01	ROLLER		4
23	574 19 65-02	TUBE		1
24	594 94 45-01	BOLT		1
25	521 99 11-02	NUT		3
26	590 63 22-01	DEFLECTOR ASSY		1
27	532 13 14-91	SHAFT		1
28	587 35 47-01	SPRING		1
29	532 11 04-52	NUT		1
30	590 30 44-03	COVER		1
31	590 30 42-03	COVER		1
32	532 13 77-29	SCREW		6
33	582 23 65-02	BELT		1
34	590 73 25-01	BUMPER ASSY		1
35	532 17 01-65	BOLT		2
36	589 81 33-01	PLUG		1
37	532 41 55-98	HOSE COUPLING		1
38	587 14 05-02	ARM		1
39	532 19 65-39	BOLT		1
40	588 78 34-01	LINK ASSY		4
41	591 16 39-01	DECAL		1
42	532 10 53-04	HUB CAP		2
43	539 12 13-22	FOOT PAD		1
44	590 88 51-01	DECAL		1
45	539 10 53-08	KEY		3

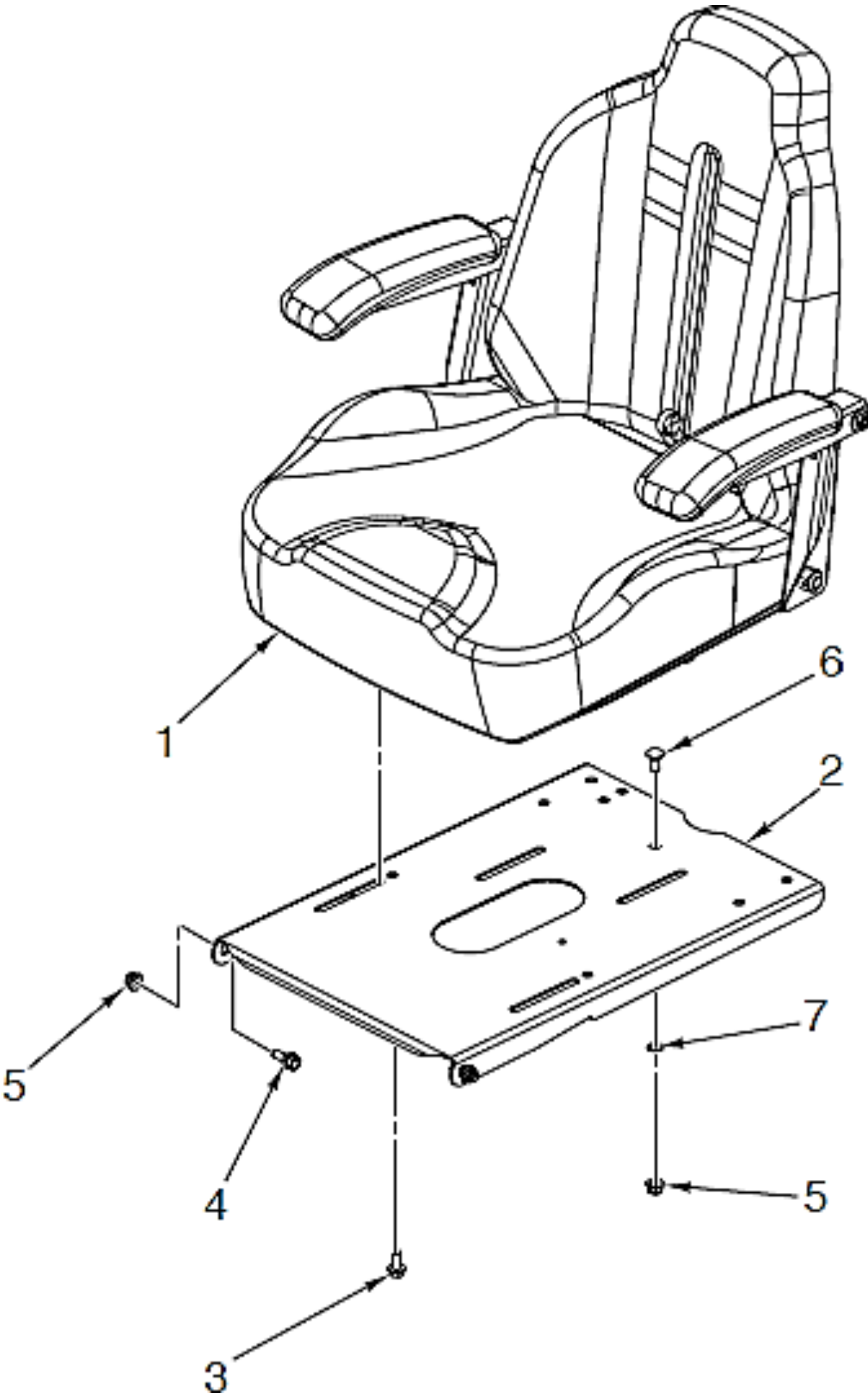

## SEAT

Z454, 967984701-00, 2019-12

Ref	Part No	Description	Remark	QTY KIT
1	579 86 61-06	SEAT ASSY	SEAT	1
2	595 08 06-02	SUPPORT	"SUPPORT SEAT, Z300/Z400"	1
3	592 85 87-02	BOLT	BOLT 5/16-18 X .75 HEX FLANGE	4
4	539 13 08-96	BOLT	SCREW 5/16-18 HEX HD GD5	2
5	594 94 44-01	NUT	NUT HEXAGON FLANGE 5/16-18	3
6	595 90 16-01	BOLT	"BOLT 5/16-18UNC X 0,75 " Grade 5"	1
7	532 42 30-63	WASHER	"WASHER 5/16""	1
	532 19 27-49	SWITCH.SEAT.DP W/RAMPS	NOT SHOWN	1
	579 86 61-08	ARMREST PAD		1

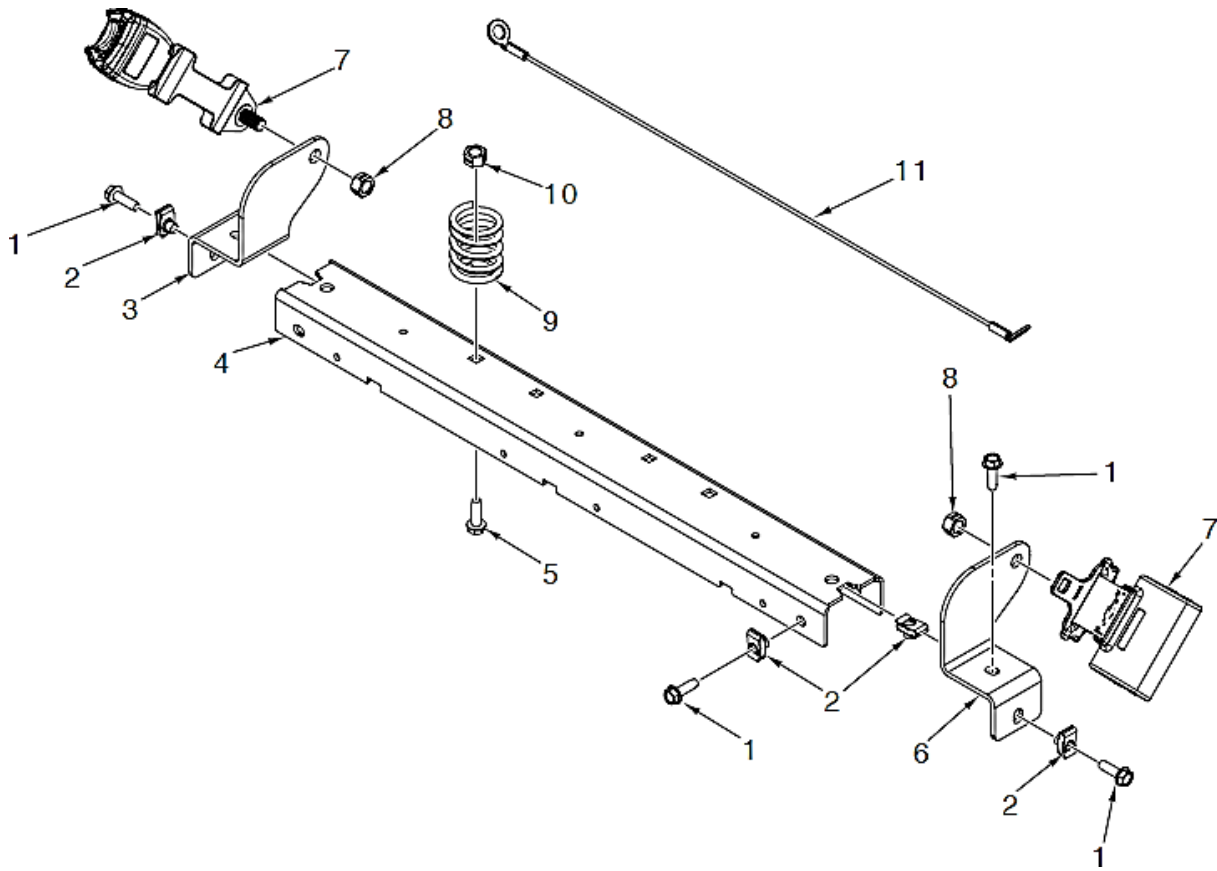

## SEAT BELT &amp; BRACKET

Z454, 967984701-00, 2019-12

Ref	Part No	Description	Remark	QTY KIT
1	596 43 38-01	SCREW	SCREW HEX HEAD 5/16-18 X 1 IN	1
2	539 10 47-63	CLIP	U-CLIP 5/16-18 NUT RETAINER	6
3	595 52 95-02	BRACKET	BRACKET SEAT BELT RH	1
4	595 52 93-02	BRACKET	BRACKET REAR SEAT	1
5	595 31 68-01	BOLT	BOLT 3/8-16UNC X 1 "	1
6	595 52 94-02	BRACKET	BRACKET SEAT BELT LH	1
7	596 32 27-02	SEAT	SEAT BELT Z400	1
8	539 99 03-94	NUT LOCKING	LOCKING NUT HEX 7/16F	1
9	587 61 33-02	SPRING	SPRING COMPRESSION	1
10	521 99 65-02	NUT	NUT HEX LOCK 3/8-16 St	4
11	595 31 33-01	CABLE	CABLE LANYARD BLACK	1

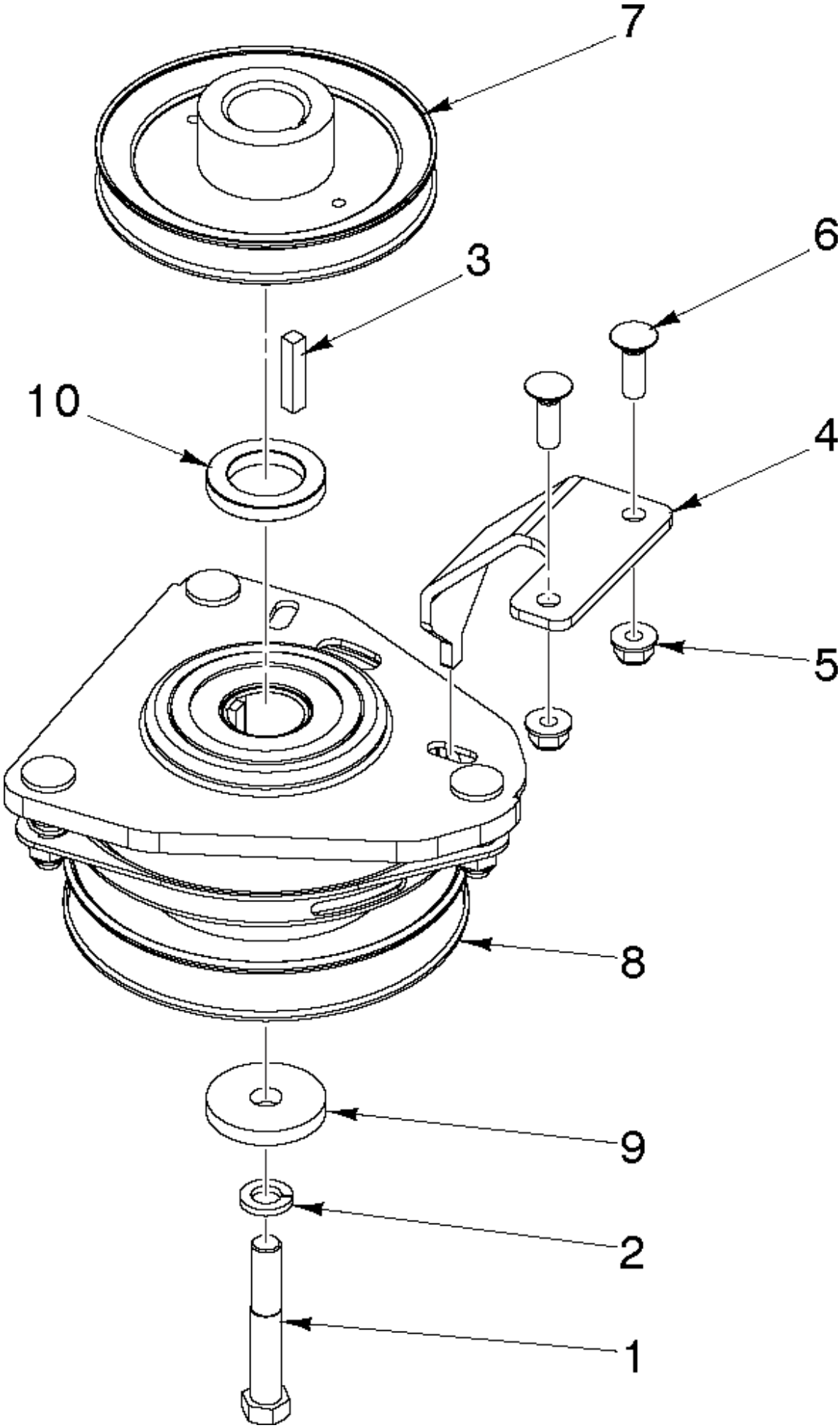

## CLUTCH

Z454, 967984701-00, 2019-12

Ref	Part No	Description	Remark	QTY KIT
1	581 33 28-07	BOLT	BOLT 2-3/4 INCH	1
2	596 23 89-01	WASHER	LOCK WASHER .455 X .776 X 7/16 IN	1
3	539 91 27-57	KEY	KEY, 1/4 SQ X 1-1/4	1
4	594 08 24-01	BRACKET	BRACKET CLUTCH STOP	1
5	594 94 44-01	NUT	NUT HEXAGON FLANGE 5/16-18	2
6	595 90 15-01	BOLT	BOLT CUP HEAD 5/16-18 x 1.02 IN	2
7	585 81 37-01	PULLEY	PULLEY DRIVE	1
8	532 17 93-35	CLUTCH	CLUTCH ELECTRIC	1
9	596 77 03-01	WASHER	WASHER 0.469X1.75 IN	1
10	525 31 39-02	SPACER	SPACER 1/4 X 1.135	1

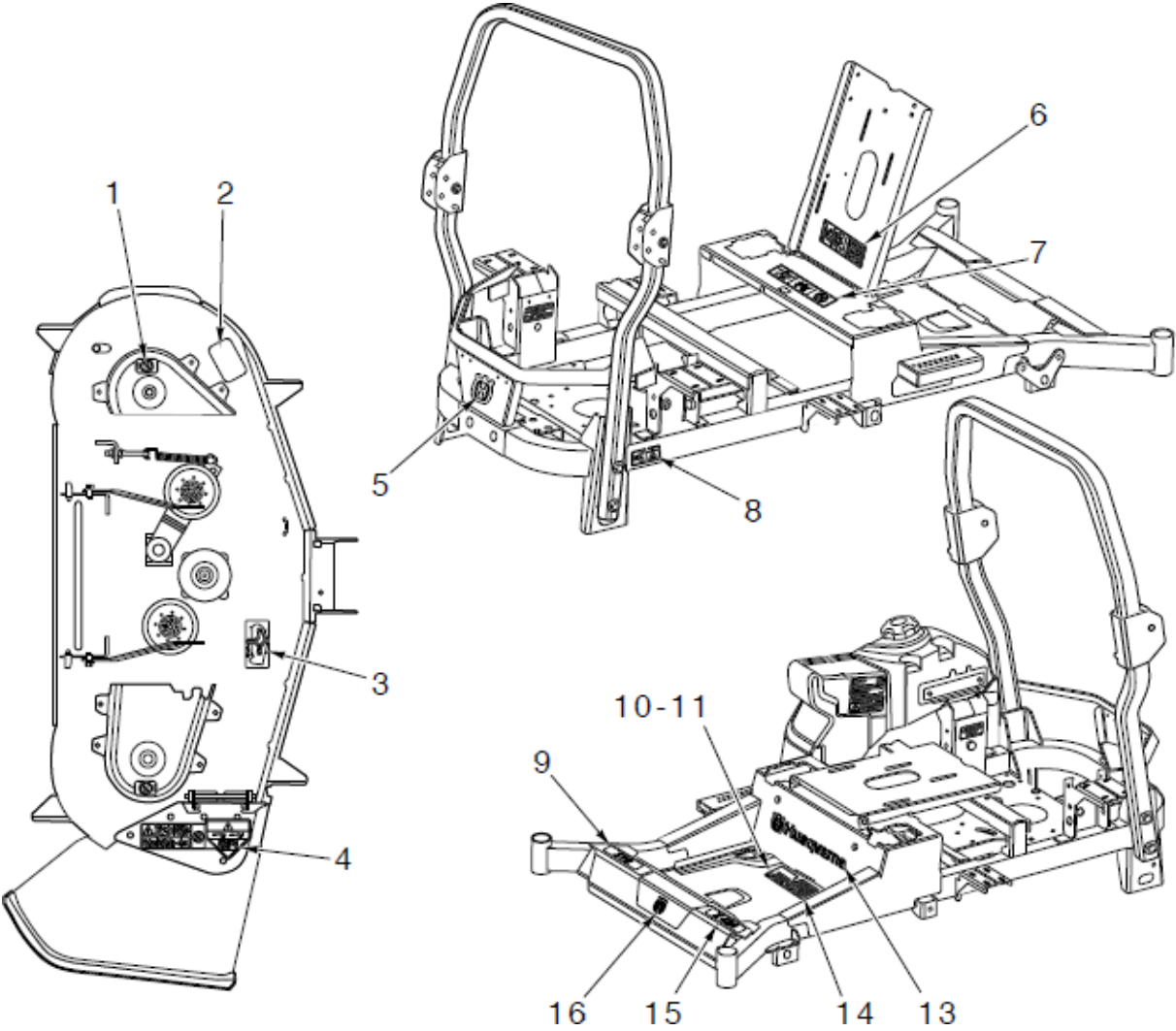



## DECALS

Z454, 967984701-00, 2019-12

Ref	Part No	Description	Remark	QTY KIT
1	589 35 79-01	DECAL		1
2	539 12 13-22	FOOT PAD		1
3	591 16 39-01	DECAL		1
4	586 97 88-01	DECAL		1
5	574 45 50-01	DECAL		1
6	590 84 68-01	DECAL		1
7	539 10 57-45	DECAL		1
8	539 10 57-44	DECAL		1
9	597 87 84-01	DECAL		1
10	590 20 94-01	DECAL		1
11	590 20 95-01	DECAL		1
13	591 35 74-01	DECAL		1
14	590 20 92-02	DECAL		1
15	597 74 34-01	DECAL		1
16	532 42 86-77	DECAL		1
	588 04 98-01	DECAL		1