

# ILLUSTRATED PARTS LIST

**MFG. ID NO. 96041043700**

**CUSTOMER CATALOG NO. TS 348XD**

**PRODUCT NO. 960 41 04-37**

**47**

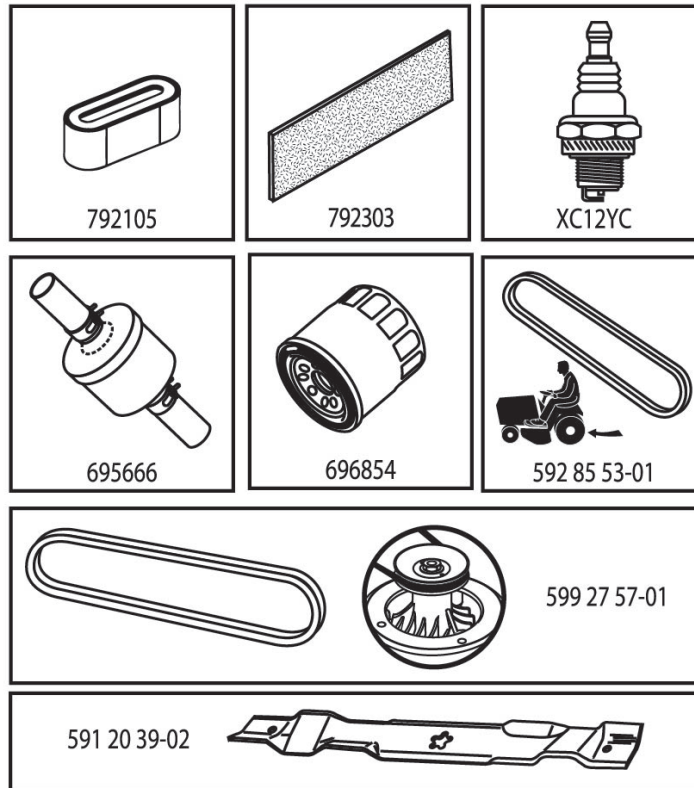

594919701

**TRACTOR - - MODEL NO. TS 348XD (96041043700), PRODUCT NO. 960 41 04-37  
DECALS 27**

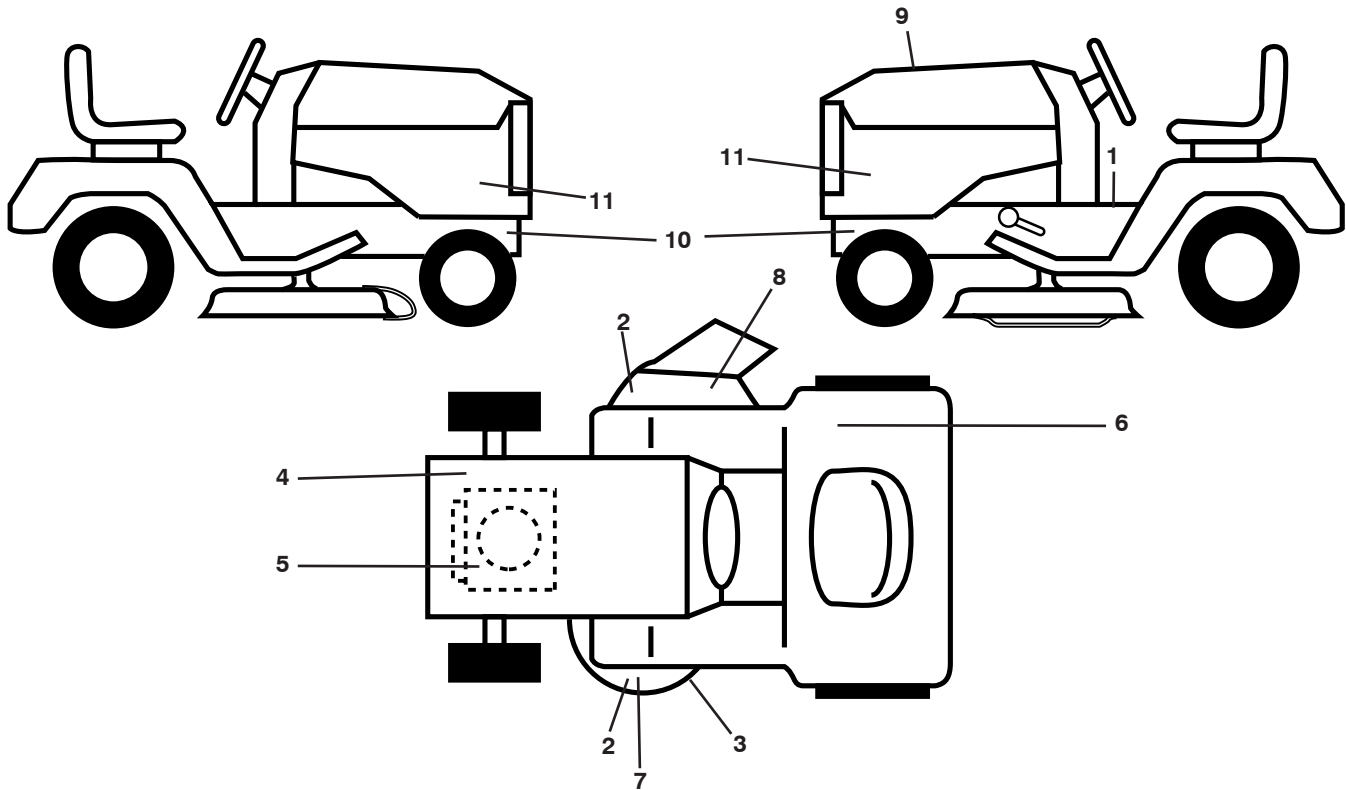

KEY NO.	PART NO.	DESCRIPTION
1	586 04 73-02	Decal, Warning
2	589 35 79-01	Decal, No Step
3	581 58 00-02	Decal, Mower Sch.
4	594 72 71-01	Decal, B&S Endurance
5	581 57 97-01	Decal, Engine Warning
6	588 04 98-01	Decal, Fend, Noise, Level
7	590 88 50-01	Decal, Deck Clearcut
8	586 97 88-01	Decal, Deflect. Warning
9	594 91 97-01	Decal, Replacement
10	581 57 96-01	Decal, Chassis Hot Muffler
11	591 44 85-01	Decal, Panel Side
--	581 72 48-01	Decal, Bypass

KEY NO.	PART NO.	DESCRIPTION
--	581 72 46-01	Decal, 6Mil Drawbar
--	581 57 98-01	Decal, Warning Service/Fire
--	532 43 98-82	Pad, Footrest, LH
--	532 43 98-81	Pad, Footrest, RH
--	114 17 17-20	Manual, Operator's (Euro)
--	114 17 18-10	Manual, Operator's (Scan)
--	114 17 20-50	Manual, Operator's (Eblock)
--	114 17 19-40	Manual, Operator's (Balt)
--	114 18 77-53	Manual, Operator's (Ukr)
--	114 18 78-76	Manual, Operator's (Turk)

**WHEELS AND TIRES**

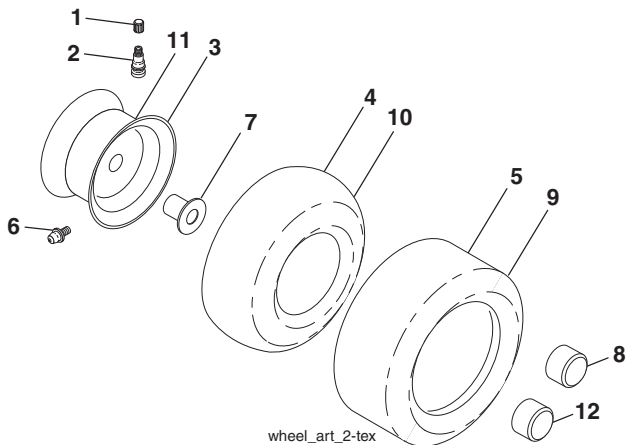

KEY NO.	PART NO.	DESCRIPTION
1	532 05 91-92	Cap, Valve, Tire
2	532 06 51-39	Stem, Valve
3	532 18 18-39	Rim Assembly, Front
4	532 00 81-34	Tube, Front (Service Item Only)
5	593 14 51-01	Tire, Front 16 x 6.5-8
6	532 00 02-78	Fitting, Grease (Front Wheel Only)
7	532 00 90-40	Bearing, Flange (Front Wheel Only)
8	532 17 50-39	Cap, Axle, Front
9	593 14 52-01	Tire, Rear 23 x 10.5-12
10	532 00 71-54	Tube, Rear (Service Item Only)
11	593 14 48-01	Rim Assembly, Rear
12	501 50 31-01	Cap, Hub, GT, PM, Black, Rear
--	532 14 43-34	Sealant, Tire (10 oz. Tube)

**NOTE:** All component dimensions given in U.S. inches  
1 inch = 25.4 mm

# TRACTOR - - MODEL NO. TS 348XD (96041043700), PRODUCT NO. 960 41 04-37 SCHEMATIC **38**

SCH27

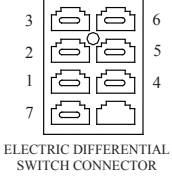
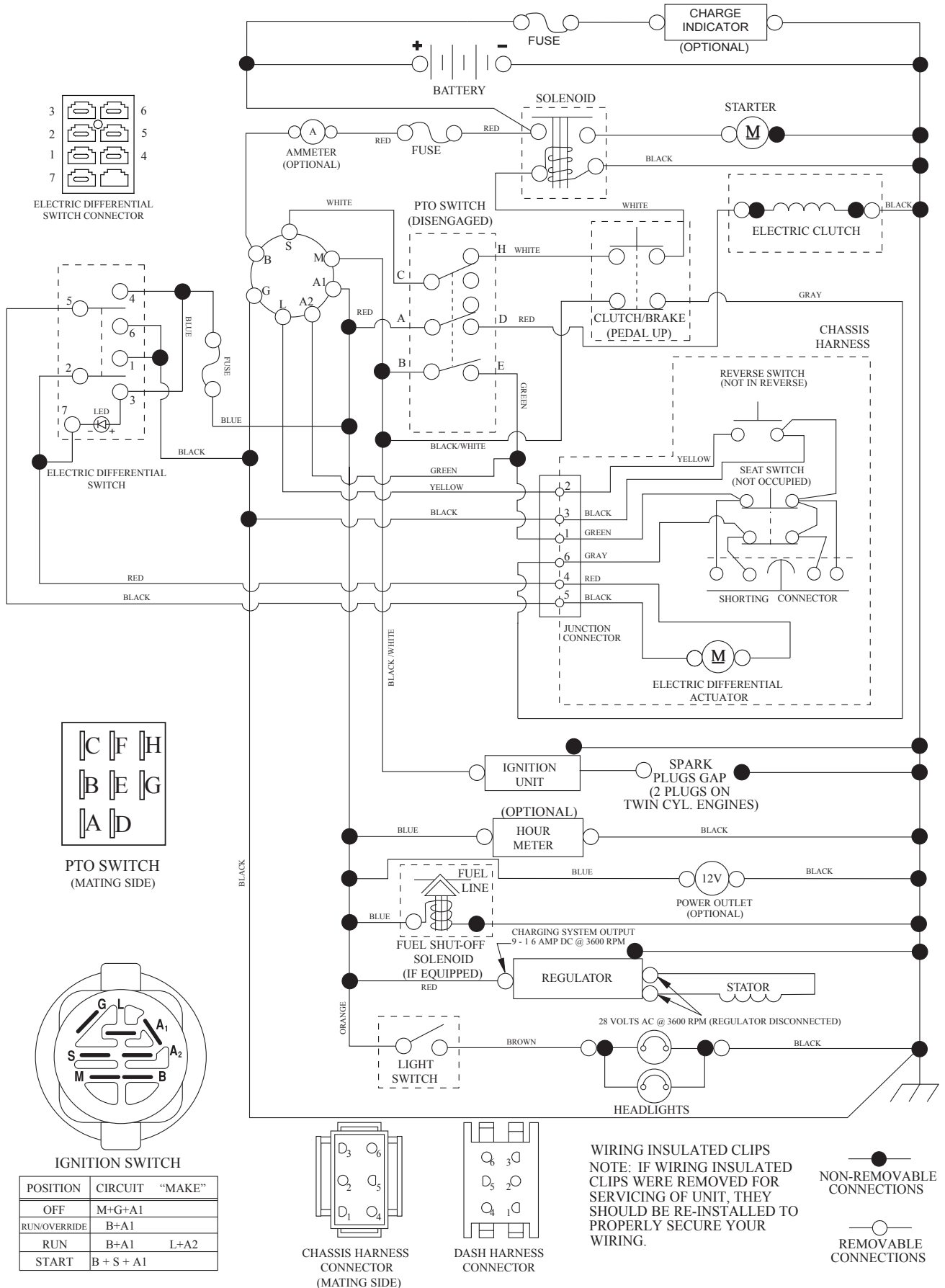

ELECTRIC DIFFERENTIAL SWITCH CONNECTOR

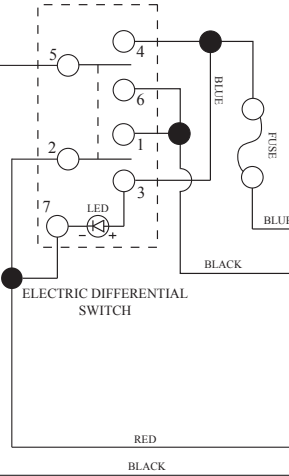

ELECTRIC DIFFERENTIAL SWITCH

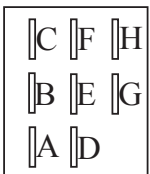

PTO SWITCH (MATING SIDE)

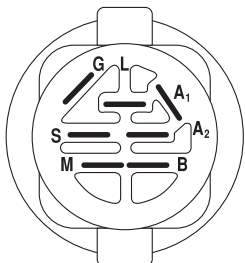

IGNITION SWITCH

POSITION	CIRCUIT "MAKE"
OFF	M+G+A1
RUN/OVERRIDE	B+A1
RUN	B+A1 L+A2
START	B + S + A1

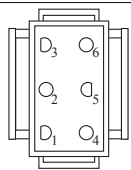

CHASSIS HARNESS CONNECTOR (MATING SIDE)

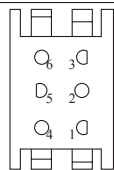

DASH HARNESS CONNECTOR

WIRING INSULATED CLIPS  
NOTE: IF WIRING INSULATED CLIPS WERE REMOVED FOR SERVICING OF UNIT, THEY SHOULD BE RE-INSTALLED TO PROPERLY SECURE YOUR WIRING.

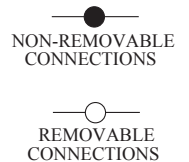

**TRACTOR - - MODEL NO. TS 348XD (96041043700), PRODUCT NO. 960 41 04-37**  
**ELECTRICAL 32**

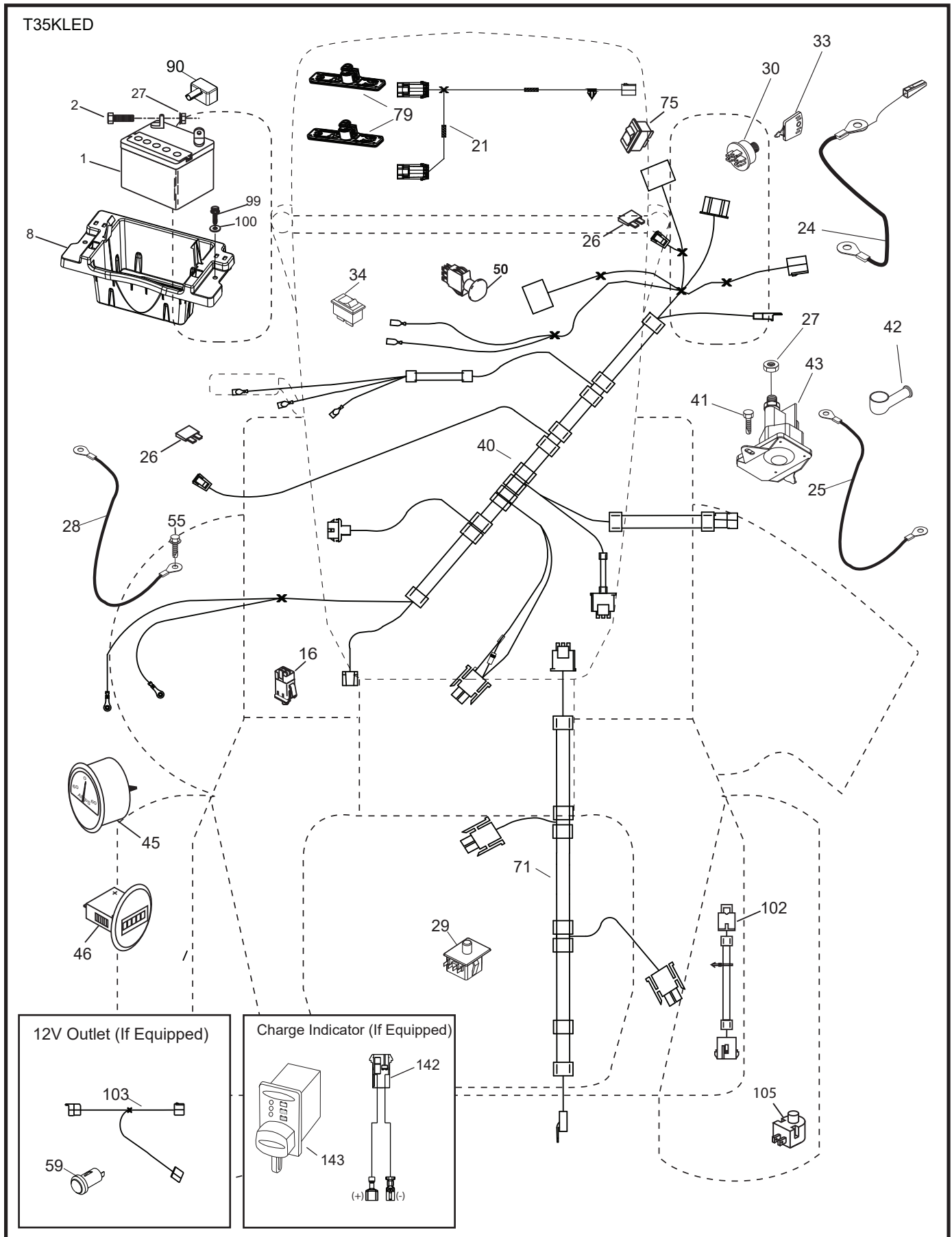

**TRACTOR - - MODEL NO. TS 348XD (96041043700), PRODUCT NO. 960 41 04-37  
ELECTRICAL 32**

<b>KEY NO.</b>	<b>PART NO.</b>	<b>DESCRIPTION</b>
1	532 16 34-65	Battery
2	874 76 04-12	Bolt Hex Hd 1/4-20 unc x 3/4
8	587 20 51-01	Battery Box
16	532 17 61-38	Switch Interlock
21	585 43 64-02	Harness Light
24	585 55 56-01	Cable, Frbatt w/Wire, 8 Ga. 8
25	585 55 55-01	Cable Starter
26	532 17 51-58	Fuse
27	596 13 36-01	Locknut, Keps 1/4-20
28	532 41 65-88	Cable Ground
29	532 19 27-49	Switch Seat
30	532 19 33-50	Switch Ign
33	532 41 19-35	Key/Chain
34	532 11 07-12	Switch Light/Reset
40	595 07 52-02	Harness, Dash, K66, Eld, Efm, Rnd
41	817 72 04-08	Screw 1/4-20 unc x 1/2
42	532 13 15-63	Cover Terminal Red
43	582 04 28-02	Solenoid
45	587 55 39-06	Gauge, Ammeter
46	587 55 40-06	Gauge, Hr Meter
50	582 10 76-02	Switch PTO
55	817 06 05-12	Screw Thdrol 5/16-18 x 3/4
71	580 51 30-01	Harness, Chassis, Frtbatt, K66, LED
75	580 36 64-01	Switch On/On
79	597 52 30-01	Light, Husgt3, LED Bat
90	532 43 53-95	Cover Terminal Battery
99	817 67 04-12	Screw Hexwsh Thdrol 1/4-20 x 3/4
100	596 13 53-01	Washer, PLain, 9/32 x7/8, Clr, Zn
102	532 40 44-54	Harness Pigtail
105	532 40 75-68	Switch Reverse

**NOTE:** All component dimensions given in U.S. inches  
1 inch = 25.4 mm

TRACTOR - - MODEL NO. TS 348XD (96041043700), PRODUCT NO. 960 41 04-37  
CHASSIS AND ENCLOSURES **39**

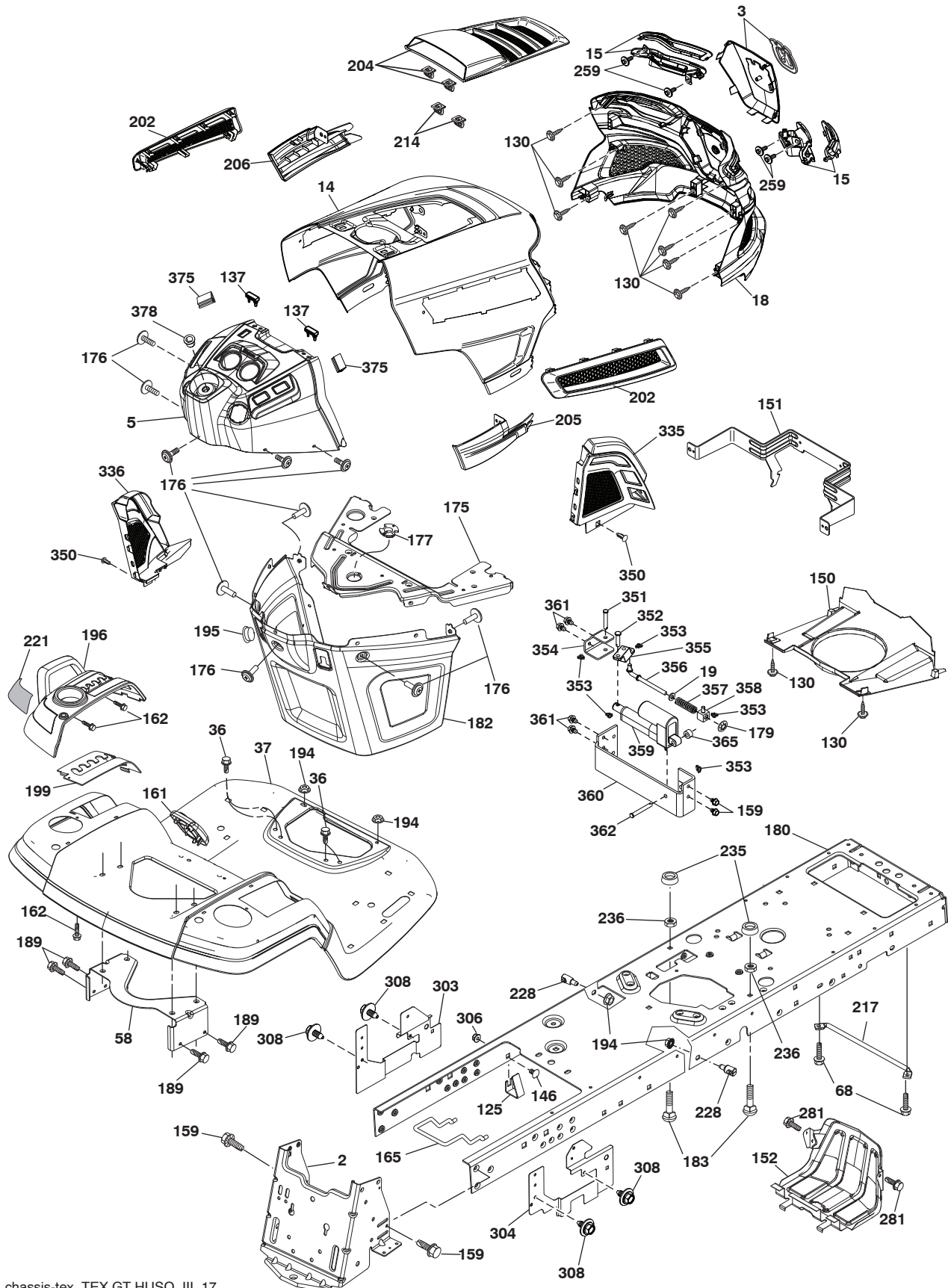

chassis-tex\_TEX GT HUSQ\_III\_17

**TRACTOR - - MODEL NO. TS 348XD (96041043700), PRODUCT NO. 960 41 04-37  
CHASSIS AND ENCLOSURES 39**

KEY NO.	PART NO.	DESCRIPTION	KEY NO.	PART NO.	DESCRIPTION
2	580 43 44-01	Drawbar	204	597 40 80-01	Kit, Top Vent (includes top vent and clip retainers)
3	597 68 82-01	Kit, Grille Applique, (includes applique cover and emblem badge)	205	532 43 97-30	Skirt Hood Side RH
5	590 74 88-30	Dash, Upper Asm, Gt2, D_R, Pto, Etc.	206	532 43 97-29	Skirt Hood Side LH
14	532 44 11-77	Hood	214	532 19 91-45	Clip Retainer
15	597 86 79-01	Kit, SVC, Hus GT3, LED Headlights (includes LH/RH lens and LH/RH housing)	217	532 40 91-67	Rod Pivot
18	597 40 71-02	Grille, Subasm, Husq, Gt3, LED	221	532 19 89-09	Reflector LH
19	596 13 32-01	Washer, 13/32 x 13/16 x 12 Ga.	228	593 82 40-01	Stud w/"D" Anti-Rotation
36	817 06 05-12	Screw 5/16-18 x 3/4	235	596 56 42-01	Spacer, Fender, Clr, Zn
37	532 44 12-08	Fender, Pnt, Tx, Gt, Ch/Fw/DL, Husq	236	873 93 05-00	Nut Center Lock 5/16-18 unc
58	532 19 43-14	Bracket Fender	259	596 43 40-01	Screw #10 x 0.500, BOS, Thread
68	596 03 07-01	Screw, Hexagon, 5/16-18 x 1/2	281	817 00 06-16	Screw 3/8-16 x 1
125	581 68 48-01	Clip Fuel Line	303	589 00 81-02	Shield Lower LH
130	596 32 17-01	Screw #10 x 0.750, BOS, Thread	304	589 00 90-02	Shield Lower RH
137	532 40 75-90	Bumper Dash	306	873 90 06-00	Nut Lock
146	581 85 79-01	Bolt	308	532 17 18-77	Bolt 5/16-18 unc x 3/4 SEMS
150	532 43 97-74	Duct Heat Hood	335	532 44 82-04	Cover RH Lower
151	532 43 66-70	Bracket Pivot Hood	336	532 44 53-09	Cover LH Lower
152	532 43 98-70	Shield Browning	350	532 44 51-43	Clip X-mas Tree
159	817 00 06-12	Screw 3/8-16 x 3/4	351	532 42 17-34	Pin Clevis .375 x 2.125
161	532 43 99-29	Window, Fuel, Husqgt 498	352	532 44 86-34	Clevis .375 x 2.125
162	596 13 41-01	Screw, Hex, Tap 1/4-15 x 1/2	353	532 17 80-62	Clip Retainer .0375
165	532 19 43-30	Bracket Support Tank	354	593 19 69-01	Support Bellcrank
175	590 60 77-02	Crossmember	355	532 44 86-36	Bellcrank Pivot Lock Diff
176	532 40 07-76	Screw 10-24 x 5/8 Wshd Qdrx	356	532 44 86-93	Link Lock Diff
177	532 19 52-28	Bushing Steering	357	532 44 86-84	Spring Compression
179	532 16 89-37	Nut Push	358	580 36 66-01	Swivel Guide
180	593 34 63-01	Chassis	359	584 39 34-01	Actuator Electric
182	532 40 68-59	Dash Lower	360	532 44 86-18	Bracket Actuator
183	595 30 57-01	Screw, Hexagon, 5/16-18 x 1-1/4	361	596 56 40-02	Bolt, HHD, 3/8-16 x 0.655, Clr, Zn
189	817 00 05-12	Screw 5/16-18 x 3/4	362	532 44 86-33	Clevis .375 x 2.42
194	596 13 57-01	Nut, Lock, Prvl, Torq 5/16-18 x .68	365	532 44 73-68	Nylon Spacer .375 x .4375L
195	532 40 41-37	Plug Hole Dash	375	586 90 82-01	Dash Clip-On Bumper
196	532 43 97-16	Console, Decklift, Husqgt, 7 Pos, .498	378	590 84 98-01	Bushing Flange
199	532 19 82-59	Plate Deck Lift	- -	532 43 18-82	Kit Guard Brush
202	597 86 77-01	Kit, Side Vents, LH/RH (includes LH/RH side vents)			

**NOTE:** All component dimensions given in U.S. inches  
1 inch = 25.4 mm

TRACTOR - - MODEL NO. TS 348XD (96041043700), PRODUCT NO. 960 41 04-37  
DRIVE **40**

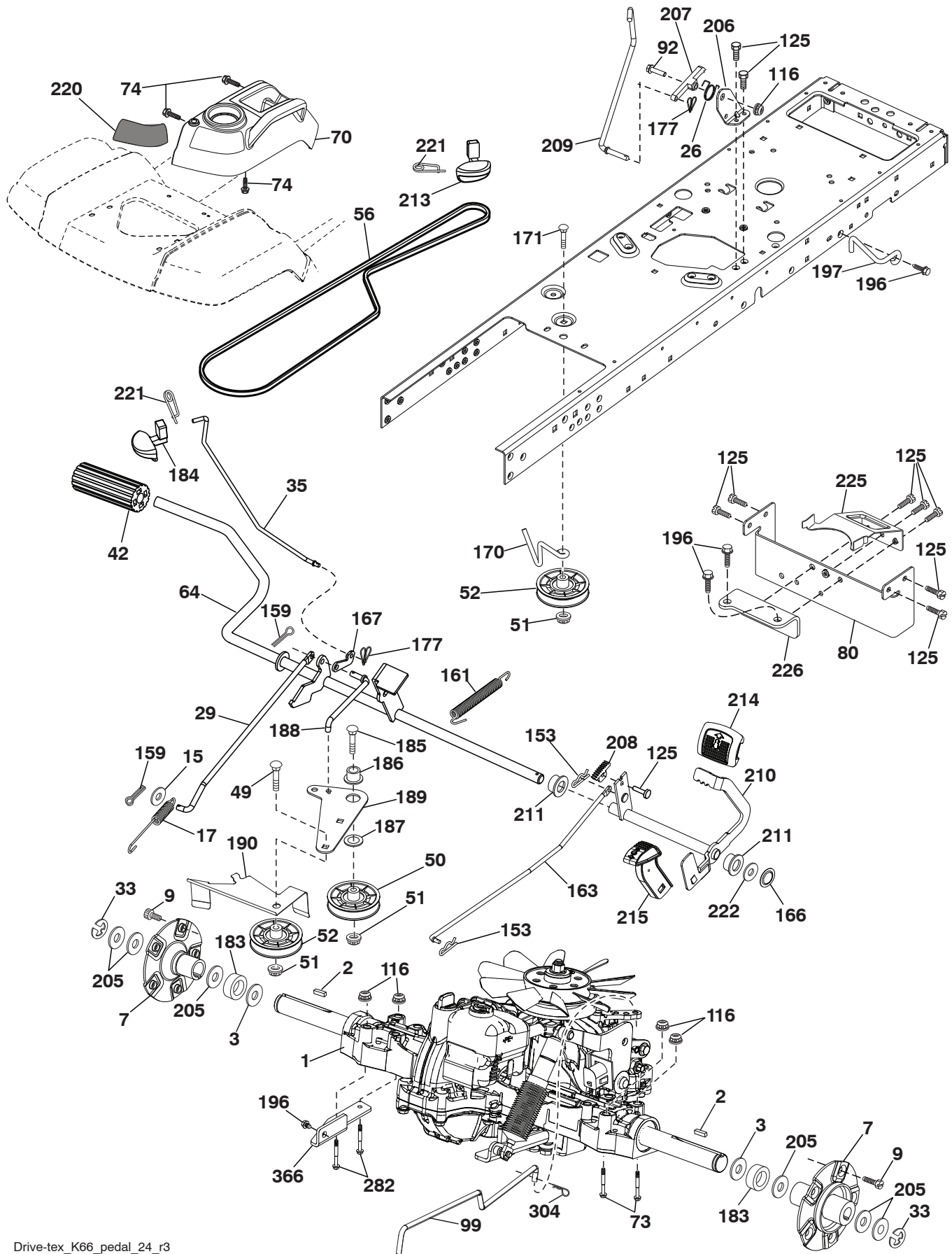



**TRACTOR - - MODEL NO. TS 348XD (96041043700), PRODUCT NO. 960 41 04-37  
DRIVE **40****

KEY NO.	PART NO.	DESCRIPTION	KEY NO.	PART NO.	DESCRIPTION
1	---	Transaxle, Tufftorq K66ELD (580402201) (Order parts from transaxle manufacturer.)	171	596 13 63-01	Bolt, Cup Head, 3/8-16 x 2
2	539 91 27-57	Key .25 x 1.25	177	587 22 53-01	Pin, Cotter, Locking, Bowtie, 1 In.
3	532 00 75-63	Washer Thrust Axle Hardened	183	587 58 74-01	Spacer
7	586 93 54-02	Hub Asm. Wheel	184	587 65 37-01	Handle Parking Brake
9	596 21 87-01	Bolt, Fit, Shank, 7/16-14 x 1-3/8"	185	872 11 06-22	Bolt Rdhd 3/8-16 unc x 2-3/4 G5
15	596 56 53-01	Washer, 3/8 x 0.08 in., St. Clr, Zinc	186	532 19 43-21	Spacer Retainer
17	532 40 10-72	Spring, Brake	187	596 13 55-01	Washer, 13/32 x 2, Clear, Zinc
26	532 19 96-79	Spring Return Cruise	188	582 21 70-01	Link Clutch Ground Drive Long
29	532 40 72-45	Rod, Brake	189	532 19 43-17	Bellcrank Ground Drive
33	812 00 00-53	Ring E	190	532 19 43-18	Keeper Bellcrank Ground Drive
35	583 86 45-02	Rod, Brake, Park	196	817 00 06-16	Screw 3/8-16 x 1
42	532 00 88-83	Cover, Pedal, Blk, Round	197	585 65 86-02	Bracket Clutch Anti-Rotation
49	596 13 62-01	Bolt, Cup Head, 3/8-16 x 3/4	205	532 12 38-00	Washer 1-1/32 x 1-5/8 x 16 Ga.
50	532 19 43-27	Pulley Idler Flat	206	532 44 85-96	Bracket Mount Latch Cruise
51	873 90 06-00	Lock Nut 3/8-16	207	587 03 14-02	Latch Control Cruise
52	532 19 43-26	Idler V-Groove	208	596 56 41-01	Gear
56	592 85 53-01	V-Belt, Drive	209	596 86 98-01	Rod, Control, Cruise, Husq, Tex
64	532 19 78-65	Shaft Asm. Pedal Brake Control	210	532 19 78-60	Rocker Asm. Pedal Control
70	532 43 96-61	Console Asm	211	532 12 01-83	Bearing Nylon
73	595 31 66-01	Bolt, HHD w/Flange, 5/16-18 Gr. 5	213	532 40 31-19	Knob Control Cruise
74	596 13 41-01	Screw, Hex, Tap, 1/4-15 x 1	214	532 42 12-63	Pedal Forward
80	589 33 34-02	Strap Torque	215	586 60 65-02	Pedal Reverse
92	595 30 57-01	Screw, Hexagon, 5/16-18 x 1-1/4	220	532 19 89-08	Reflector RH
99	582 40 47-01	Spring Bypass	221	532 40 31-87	Retainer Spring Clip Handle
116	596 13 57-01	Nut, Lock, Prvl, Torq, 5/16-18 x .68	222	879 21 20-10	Washer 21/32 x 1-1/4 x 10 Ga.
125	817 00 05-12	Screw 5/16-18 x 3/4	225	532 40 73-11	Keeper Belt
153	532 00 44-97	Retainer, Spring 1", Zinc	226	532 40 71-09	Bracket Mount Torque
159	596 02 95-01	Pin, Cotter 1/8 dia x 3/4	282	874 49 05-48	Bolt 5/16-18 x 3.0 G5
161	532 10 57-09	Spring, Return, Clutch	304	532 42 33-03	Pin
163	532 40 72-46	Rod Pedal Control	366	580 62 62-02	Bracket Reinforcement
166	532 42 91-64	Nut Push .625			
167	532 40 52-57	Latch Brake Parking			
170	532 19 43-22	Keeper V-Idler Centerspan			

**NOTE:** All component dimensions given in U.S. inches  
1 inch = 25.4 mm

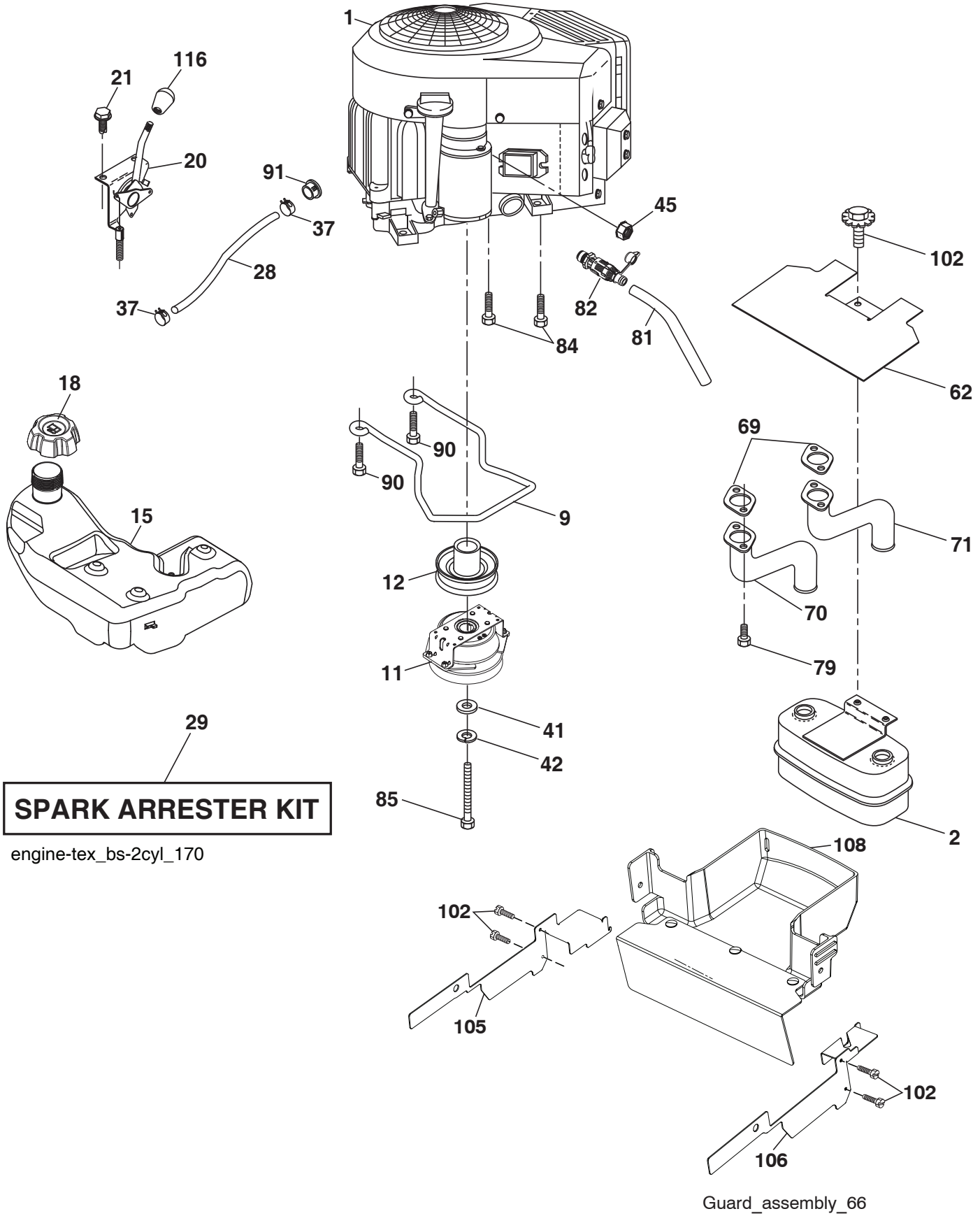

**TRACTOR - - MODEL NO. TS 348XD (96041043700), PRODUCT NO. 960 41 04-37  
ENGINE 24**

<b>KEY NO.</b>	<b>PART NO.</b>	<b>DESCRIPTION</b>
1	- - - - -	Engine B&S Model No. 44U877-0023-B1 (594083601)(Order parts from engine manufacturer.)
2	589 81 87-01	Muffler, Asm, Twin
9	501 83 26-02	Keeper Asm. Belt Engine
11	587 24 14-01	Clutch Electric
12	532 19 43-43	Pulley Engine
15	532 19 34-99	Tank, Fuel, 4 Gal.
18	584 24 87-02	Cap Asm
20	532 42 43-41	Control Throttle
21	596 32 17-01	Screw #10 x 0.750, BOS Thread
28	532 40 11-35	Fuel Line
29	532 13 71-80	Spark Arrester Kit
37	532 12 34-87	Clamp Hose
41	532 12 61-97	Washer 1-1/2 OD x 15/32 ID x .250
42	596 23 89-01	Washer, 7/16 in., Clr, Zn
45	596 13 36-01	Locknut, Keps, 1/4-20
62	532 43 40-17	Shield Heat Muffler
69	532 16 53-91	Gasket
70	581 88 11-01	Tube Exhaust LH
71	581 88 10-01	Tube Exhaust RH
79	596 13 42-02	Screw, Socket, 5/16-18 x 1, Clr, Zn
81	532 14 84-56	Oil Tube Drain
82	532 42 82-87	Valve Oil Drain
84	817 06 06-20	Screw 3/8-16 x 1-1/4
85	501 60 69-01	Bolt 7/16-20 x 3.0 x Gr. 5
90	817 00 06-16	Screw 3/8-16 x 1
91	532 18 74-95	Bushing
102	817 00 05-12	Screw 5/16 x 3/4
105	591 20 49-02	Shield Chassis LH
106	591 20 50-02	Shield Chassis RH
108	592 72 71-01	Cover Engine Pulley
116	539 13 26-24	Knob Soft Touch

**NOTE:** All component dimensions given in U.S. inches  
1 inch = 25.4 mm

TRACTOR - - MODEL NO. TS 348XD (96041043700), PRODUCT NO. 960 41 04-37  
STEERING ASSEMBLY **41**

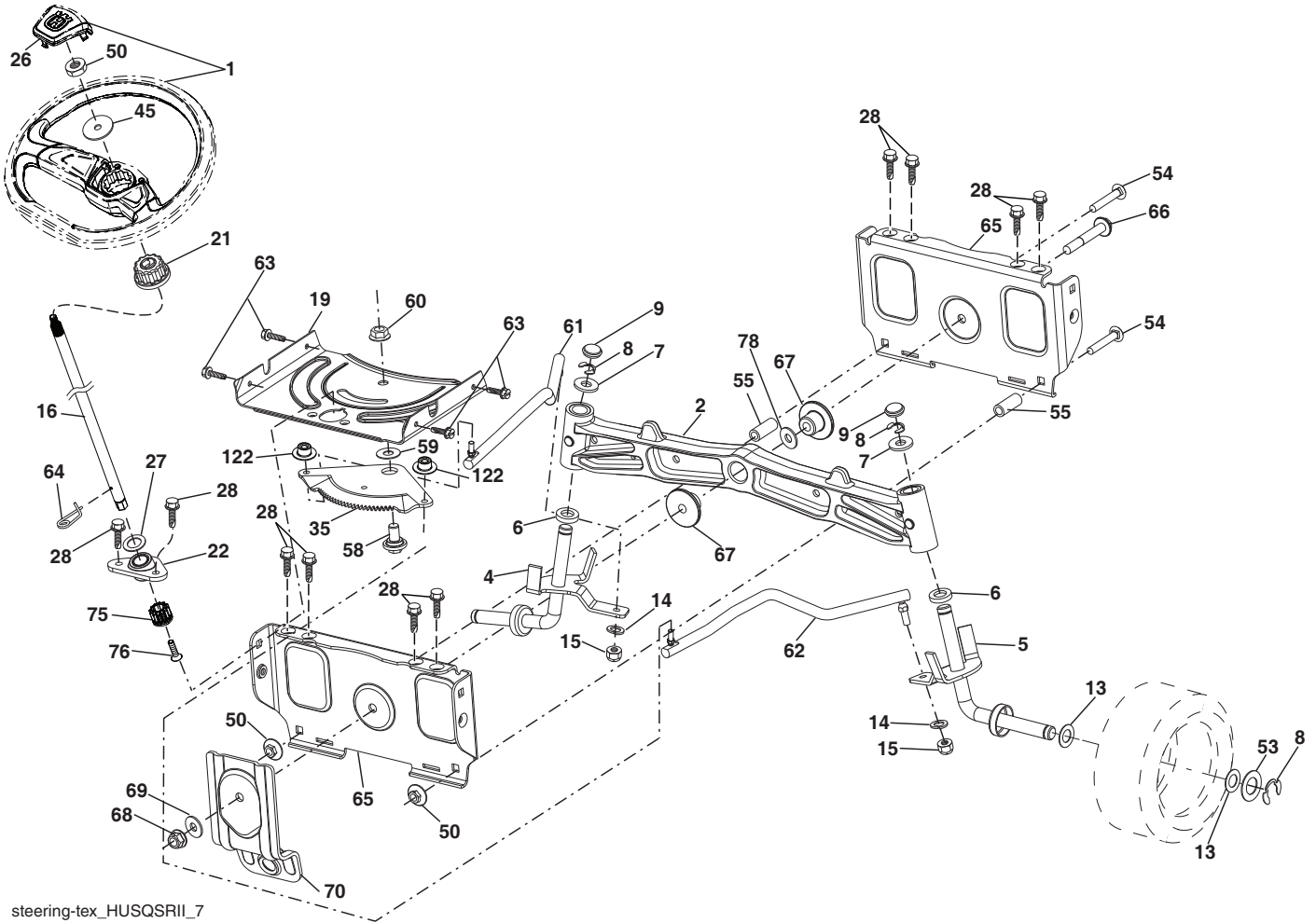

steering-tex\_HUSQSR11\_7

**TRACTOR - - MODEL NO. TS 348XD (96041043700), PRODUCT NO. 960 41 04-37  
STEERING ASSEMBLY 41**

KEY NO.	PART NO.	DESCRIPTION
1	597 86 61-01	Wheel, Steering, Kit (includes steering wheel and cap)
2	532 19 59-68	Axle Asm., Front
4	532 40 31-72	Spindle Asm. LH
5	532 40 31-73	Spindle Asm. RH
6	532 00 62-66	Washer Thrust, .75 x 1.230
7	532 12 17-48	Washer 25/32 x 1-5/8 x 16 Ga.
8	812 00 00-29	Ring, Clip #T5304-75
9	532 12 12-32	Cap, Spindle
13	532 12 17-49	Washer 25/32 x 1-1/4 x 16 Ga.
14	596 23 87-01	Washer, Spring, Lock, .381 ID x .680
15	873 54 06-00	Nut, Crown Lock 3/8-24 unf
16	587 01 60-02	Steering Shaft
19	532 19 47-29	Plate Steering
21	586 84 02-01	Adapter Wheel Steering
22	585 02 99-01	Bearing
26	594 94 91-01	Cap, Wheel, Steer, Husq2, MS498
27	596 93 34-01	Washer, Plain
28	817 00 06-12	Screw 3/8-16 x 3/4
35	532 19 47-32	Gear, Sector Plate
45	587 01 64-01	Washer 3/8 ID 2-3/8 OD 12 Ga. PLTD
50	873 90 06-00	Nut Lock Flg 3/8-16 unc
53	532 18 89-67	Washer Hardened .793 x 1.637 x .060
54	874 76 06-36	Bolt Hex 3/8-16 unc x 2-1/4
55	532 41 47-36	Bolt Hex 3/8-16 unc x 2-1/4
58	532 19 47-47	Bolt Shoulder Sector Pivot CFM
59	532 19 47-48	Washer Thrust Sector Steering
60	873 97 10-00	Nut Flange Lock 5/8-11
61	597 07 02-02	Draglink, LH, Adj
62	597 07 03-02	Draglink, RH, Adj
63	817 00 05-12	Screw 5/16-18 x 3/4
64	532 19 98-49	Retainer Clip Spring Steering
65	532 19 47-34	Brace Axle Front
66	871 02 07-48	Bolt Hex Fghd 7/16-14 x 3 Serr
67	532 19 47-37	Bushing PM Front Axle
68	873 90 07-00	Nut Lock Flange 7/16-14 Gr. 5
69	532 19 91-62	Washer 1.5 x .505 x .118
70	585 33 88-01	Bracket Deck Susp. Front
75	580 68 37-01	Pinion
76	580 68 36-01	Screw Head Sock
78	532 05 70-79	Washer Thrust
122	532 44 49-62	Cap Gear Sector

**NOTE:** All component dimensions given in U.S. inches  
1 inch = 25.4 mm

TRACTOR - - MODEL NO. TS 348XD (96041043700), PRODUCT NO. 960 41 04-37  
MOWER DECK 44

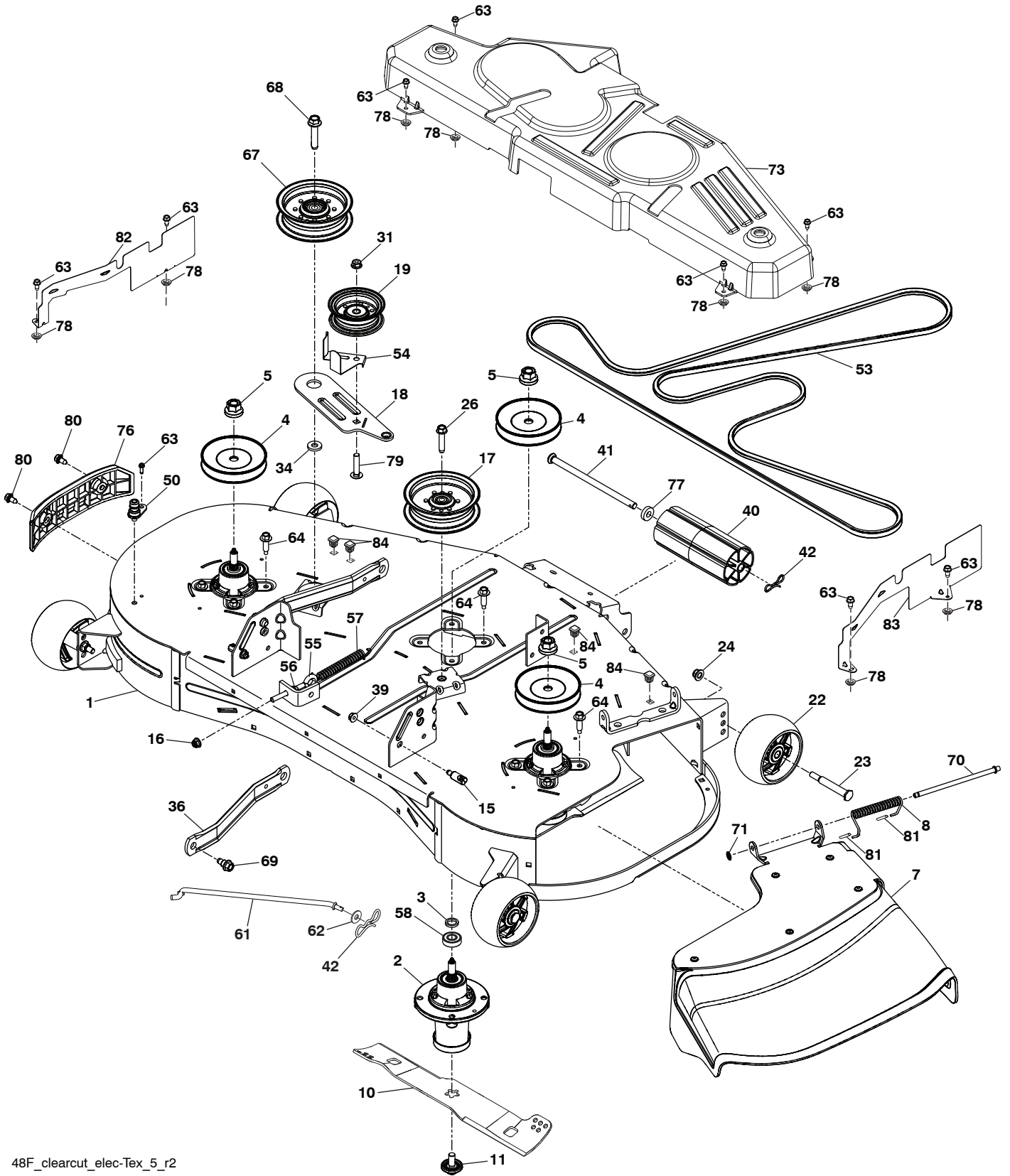

48F\_clearcut\_elec-Tex\_5\_r2

**TRACTOR - - MODEL NO. TS 348XD (96041043700), PRODUCT NO. 960 41 04-37  
MOWER DECK 44**

KEY NO.	PART NO.	DESCRIPTION	KEY NO.	PART NO.	DESCRIPTION
1	583 81 00-01	Kit, SVC 48F	54	532 14 10-43	Guard, Belt
2	539 13 18-98	Housing Assembly	55	596 24 08-01	Bolt, Eyelet, 5/16-18 x 3-1/2
3	532 18 76-90	Washer-Spacer	56	596 03 92-01	Nut, Lock, Hex, 5/16-18, Clear, Zin
4	532 17 34-34	Pulley, Mandrel	57	587 35 84-01	Spring Extn.
5	596 13 48-01	Nut, Hex, 9/16-18 x 1.010	58	532 11 04-85	Ball Bearing
7	593 64 97-01	Deflector Asm. 48"	61	596 27 44-01	Rod, Anti-Sway, Tex, Clr, Zinc
8	587 35 47-01	Spring - Torsion	62	596 13 32-01	Washer, 13/32 x 13/16 x 12 Ga.
10	591 20 39-02	Blade	63	596 63 73-01	Screw, Hex w/Collar, 1/4-20 x 5/8
11	532 19 30-03	Bolt Washer Assy 7/16-20	64	584 95 39-01	BoltHexWasherHead.313-18x1.19
15	593 82 40-01	Stud w/"D" Anti-Rotation	67	532 19 61-06	Pulley Idler
16	594 94 44-01	Nut, Hexagon, Flange, 5/16-18	68	596 56 40-03	Bolt, Hex, 3/8-16 x 1.78, Clr, Zinc
17	532 19 61-04	Pulley, Idler Spec. Hub	69	532 19 65-39	Bolt Shoulder
18	588 81 22-02	Arm Idler	70	595 29 70-01	Rod, Hinge
19	532 19 31-97	Pulley, Idler	71	532 11 04-52	Nut Push
22	589 52 73-01	Wheel, Gauge	73	591 20 46-01	Cover Mandrel
23	596 43 44-04	Bolt, Shoulder, 3/8-16 x 3-5/8"	76	582 54 11-03	Bumper Side Trim
24	521 99 65-02	Nut 3/8-16 Hex Flg Nyloc	77	582 36 05-01	Bushing Nose Roller
26	588 43 83-01	Screw 7/16-14 x 2.125 Wsh	78	532 42 30-62	Palnut 1/4
31	873 90 06-00	Nut Lock Flng 3/8-16 unc	79	596 13 62-01	Bolt, Cup Head, 3/8-16 x 3/4
34	532 17 85-15	Washer, Flat Hardened	80	532 17 01-65	Bolt 5/16
36	532 19 51-85	Arm, Susp., Rear	81	532 10 53-04	Cap Sleeve
39	596 13 57-01	Nut, Lock, Prvl, Torq, 5/16-18 x .68	82	591 20 47-02	Shield Deck LH
40	532 17 60-66	Roller, Nose, 48"	83	591 20 48-02	Shield Deck RH
41	594 09 25-01	Rod, Roller, Narrow, Nose, V2	84	596 95 22-01	Plug, Hole, Square
42	532 19 42-08	Pin Cotter			
50	532 41 55-98	Washout Port			
53	599 27 57-01	Belt Drive, 48 FCS, Tractor			

**NOTE:** All component dimensions given in U.S. inches  
1 inch = 25.4 mm

**TRACTOR - - MODEL NO. TS 348XD (96041043700), PRODUCT NO. 960 41 04-37**  
**MOWER LIFT 45**

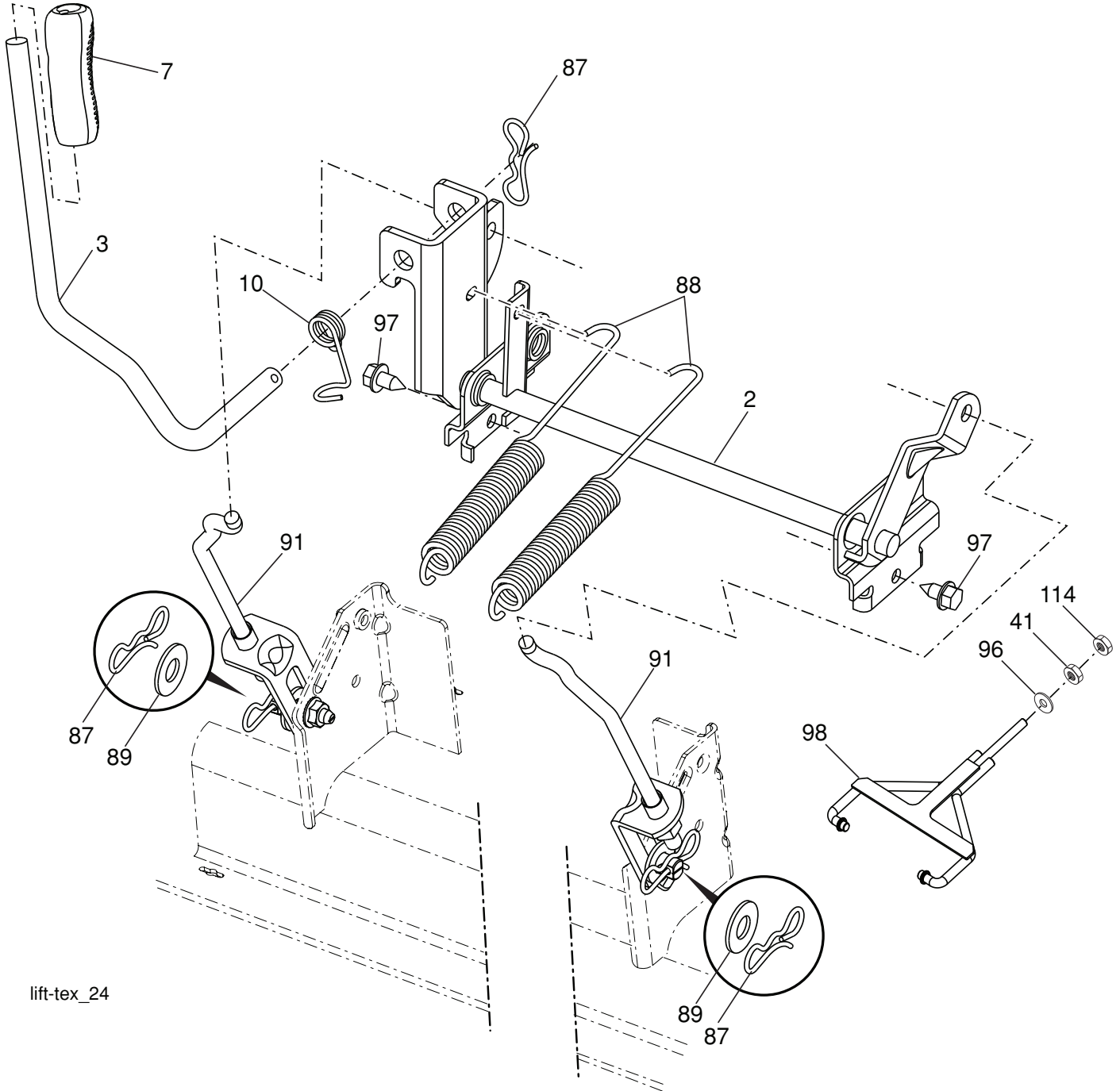

lift-tex\_24

KEY NO.	PART NO.	DESCRIPTION
2	532 42 20-27	Shaft Asm., Lift
3	596 27 06-01	Lever, Lift, Handle, Clear, Zinc
7	580 96 23-01	Grip, Lever
10	532 19 63-14	Spring Torsion
41	589 46 49-02	Nut, Lift, Link, Clr, Zn
87	532 19 42-09	Pin Cotter 7/16 Bow Tie Lock
88	532 19 53-04	Spring Lift Assist
89	819 19 19-12	Washer Clear Zinc

KEY NO.	PART NO.	DESCRIPTION
91	589 46 48-05	Link, Asm, Lift, Rear, 10.540
96	593 84 21-01	Bushing
97	817 00 06-12	Screw 3/8-16 x .75
98	574 82 25-01	Link Lift Susp. Front Mower
114	873 36 07-00	Nut Jam 7/16-20

**NOTE:** All component dimensions given in U.S. inches  
 1 inch = 25.4 mm



**TRACTOR - - MODEL NO. TS 348XD (96041043700), PRODUCT NO. 960 41 04-37  
SEAT ASSEMBLY 42**

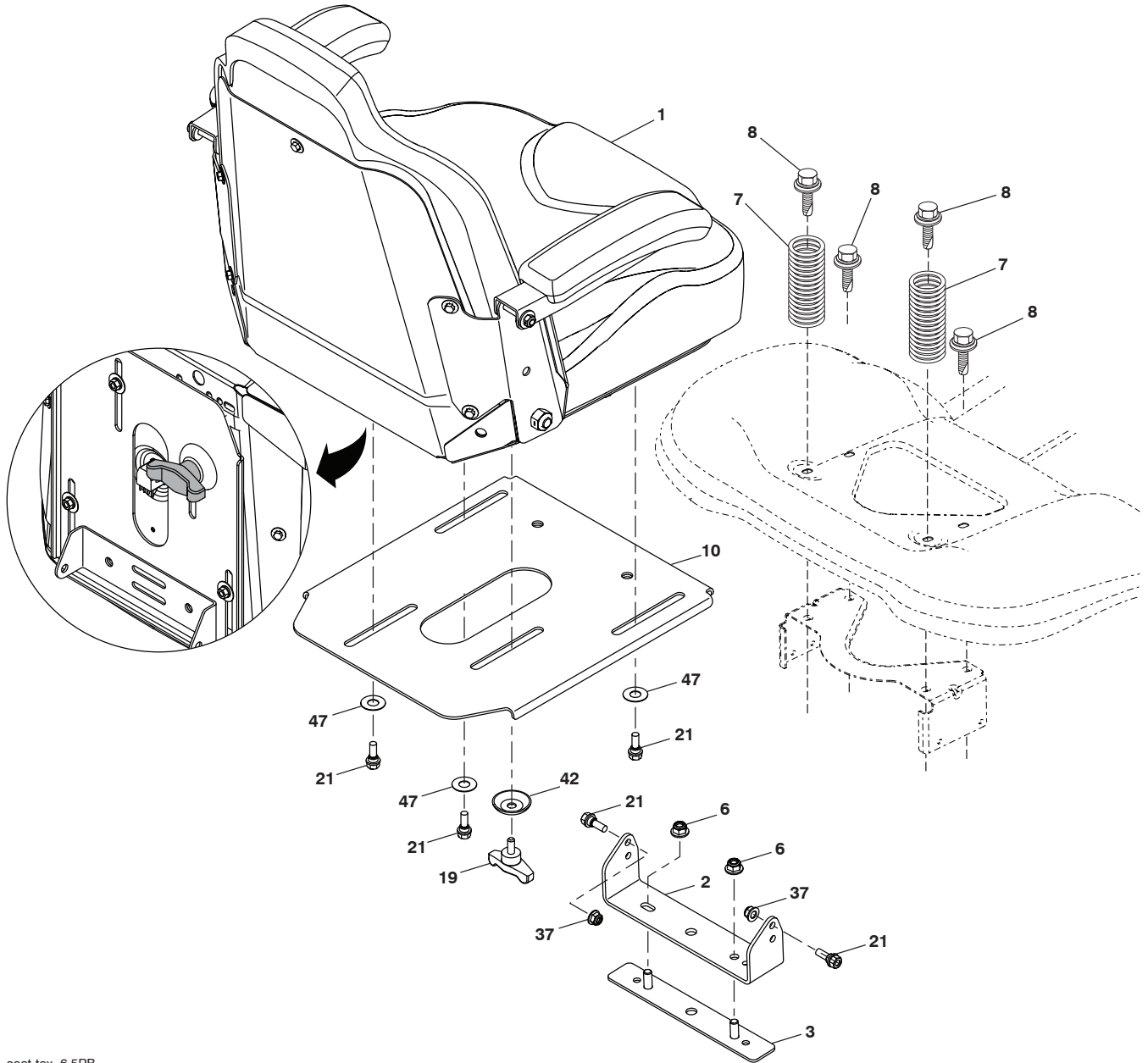

seat-tex\_6.5PB

KEY NO.	PART NO.	DESCRIPTION
1	590 33 73-01	Seat
2	590 33 66-02	Bracket Pivot Fender
3	590 77 76-02	Bracket Pivot Seat
6	521 99 65-02	Nut, Lock 3/8-16 unc
7	590 81 23-01	Spring, Seat Cprsn
8	532 17 18-77	Bolt 5/16-18 x 3/4 w/Sems
10	590 48 17-02	Pan, Seat
19	590 69 15-01	Knob Seat

KEY NO.	PART NO.	DESCRIPTION
21	596 23 11-01	Bolt, Hex, Washer, 5/16-18 x .910
37	594 94 44-01	Nut, Hexagon, Flange, 5/16-18
42	532 19 93-71	Washer
47	590 35 11-01	Washer Nylon .05 x 1.12 x .033

**NOTE:** All component dimensions given in U.S. inches  
1 inch = 25.4 mm

