

ILLUSTRATED PARTS LIST

MODEL NO. 96051018800

CUSTOMER CATALOG NO. TC 130

PRODUCT NO. 960 51 01-88

47

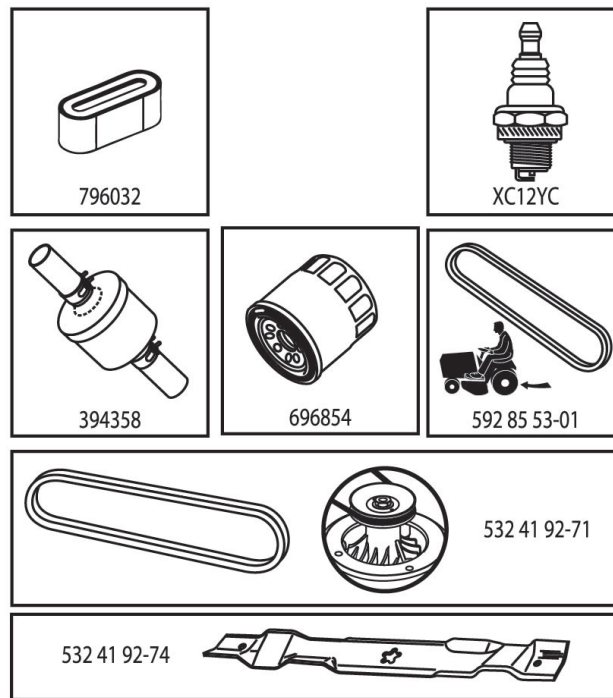

596011801

TRACTOR - MODEL NO. TC 130 (96051018800), PRODUCT NO. 960 51 01-88
DECALS 27

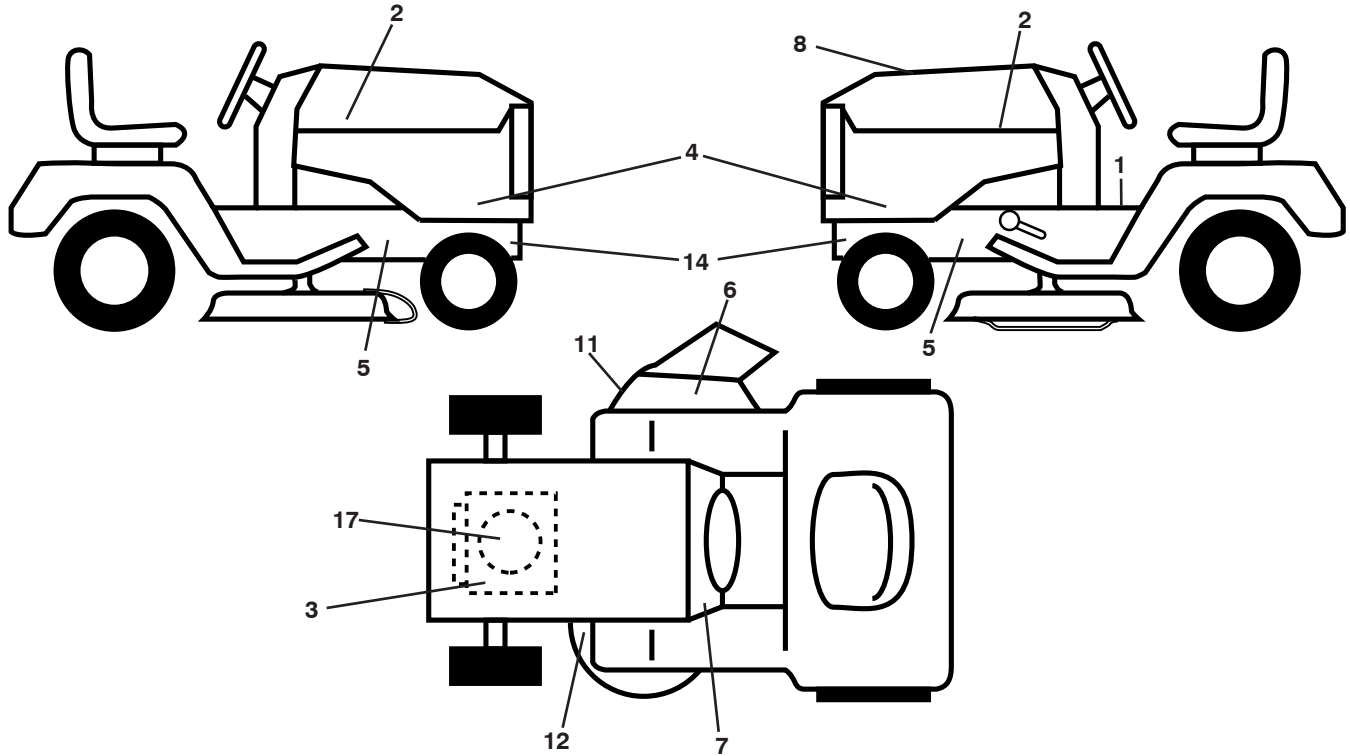

KEY NO.	PART NO.	DESCRIPTION
1	586 35 06-01	Decal Saddle Fnndr
2	501 13 14-01	Decal, Hood Logo
3	581 57 97-01	Decal, Warning Eng. Symbols
4	587 39 64-01	Decal, Hood Panel
5	581 57 96-01	Decal, Chassis Hot Muffler
6	584 90 46-01	Decal, Deck/Deflect. Warning
7	586 06 62-01	Decal, Snowflake
8	596 01 18-01	Decal, Rpl
11	581 57 94-01	Decal, Warning DFlect/Ctfngr
12	581 58 00-04	Decal, Mower V-Belt Schematic
14	581 57 98-01	Decal, Warning

KEY NO.	PART NO.	DESCRIPTION
17	587 38 50-01	Decal, BS Engine
--	581 72 48-01	Decal, Bypass
--	532 44 14-09	Pad, Footrest, LH
--	532 44 14-10	Pad, Footrest, RH
--	114 20 52-20	Manual Oper. Euro
--	114 20 53-10	Manual Oper. Scan
--	114 20 54-50	Manual Oper. E-Bloc
--	114 20 55-40	Manual Oper. Baltic
--	114 20 57-53	Manual Oper. Ukr
--	114 20 56-76	Manual Oper. Turk

WHEELS AND TIRES

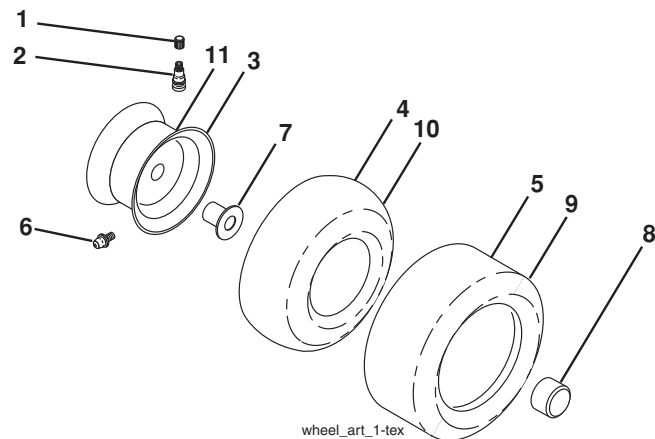

KEY NO.	PART NO.	DESCRIPTION
1	532 05 91-92	Cap Valve Tire
2	532 06 51-39	Stem Valve
3	532 42 52-61	Rim Asm 6 x 3.25 Front
4	532 42 16-52	TubeFront13x5-6(ServiceItemOnly)
5	532 12 34-10	Tire Front 13 x 5-6
6	532 00 02-78	Fitting Grease (Front Wheel Only)
7	532 00 90-40	Bearing Flange (Front Wheel Only)
8	532 17 50-39	Cap Axle Blk 1 50 x 1 00
9	532 10 62-30	Tire Rear 16 x 6.5-8
10	532 00 71-54	Tube Rear (Service Item Only)
11	532 42 52-62	Rim Asm 8 x 5.375 Rear
--	532 14 43-34	Sealant, Tire (10 oz. Tube)

NOTE: All component dimensions given in U.S. inches
 1 inch = 25.4 mm

TRACTOR - MODEL NO. TC 130 (96051018800), PRODUCT NO. 960 51 01-88

SCHEMATIC **38**

SCH17

NOTE
YOUR TRACTOR IS EQUIPPED WITH A SPECIAL ALTERNATOR SYSTEM. THE LIGHTS ARE NOT CONNECTED TO THE BATTERY, BUT HAVE THEIR OWN ELECTRICAL SOURCE. BECAUSE OF THIS, THE BRIGHTNESS OF THE LIGHTS WILL CHANGE WITH ENGINE SPEED. AT IDLE THE LIGHTS WILL DIM. AS THE ENGINE SPEED IS INCREASED, THE LIGHTS WILL BECOME THEIR BRIGHTEST.

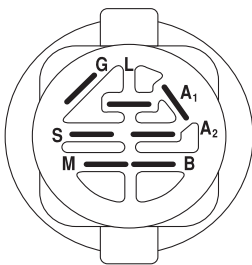

IGNITION SWITCH

POSITION	CIRCUIT	"MAKE"
OFF	M+G+A1	
RUN/OVERRIDE	B+A1	
RUN	B+A1	L+A2
START	B + S + A1	

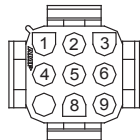

CHASSIS HARNESS CONNECTOR (C1) (MATING SIDE)

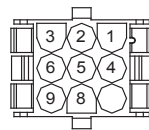

DASH HARNESS CONNECTOR (C1) (MATING SIDE)

WIRING INSULATED CLIPS
NOTE: IF WIRING INSULATED CLIPS WERE REMOVED FOR SERVICING OF UNIT, THEY SHOULD BE RE-INSTALLED TO PROPERLY SECURE YOUR WIRING.

● NON-REMOVABLE CONNECTIONS

○ REMOVABLE CONNECTIONS

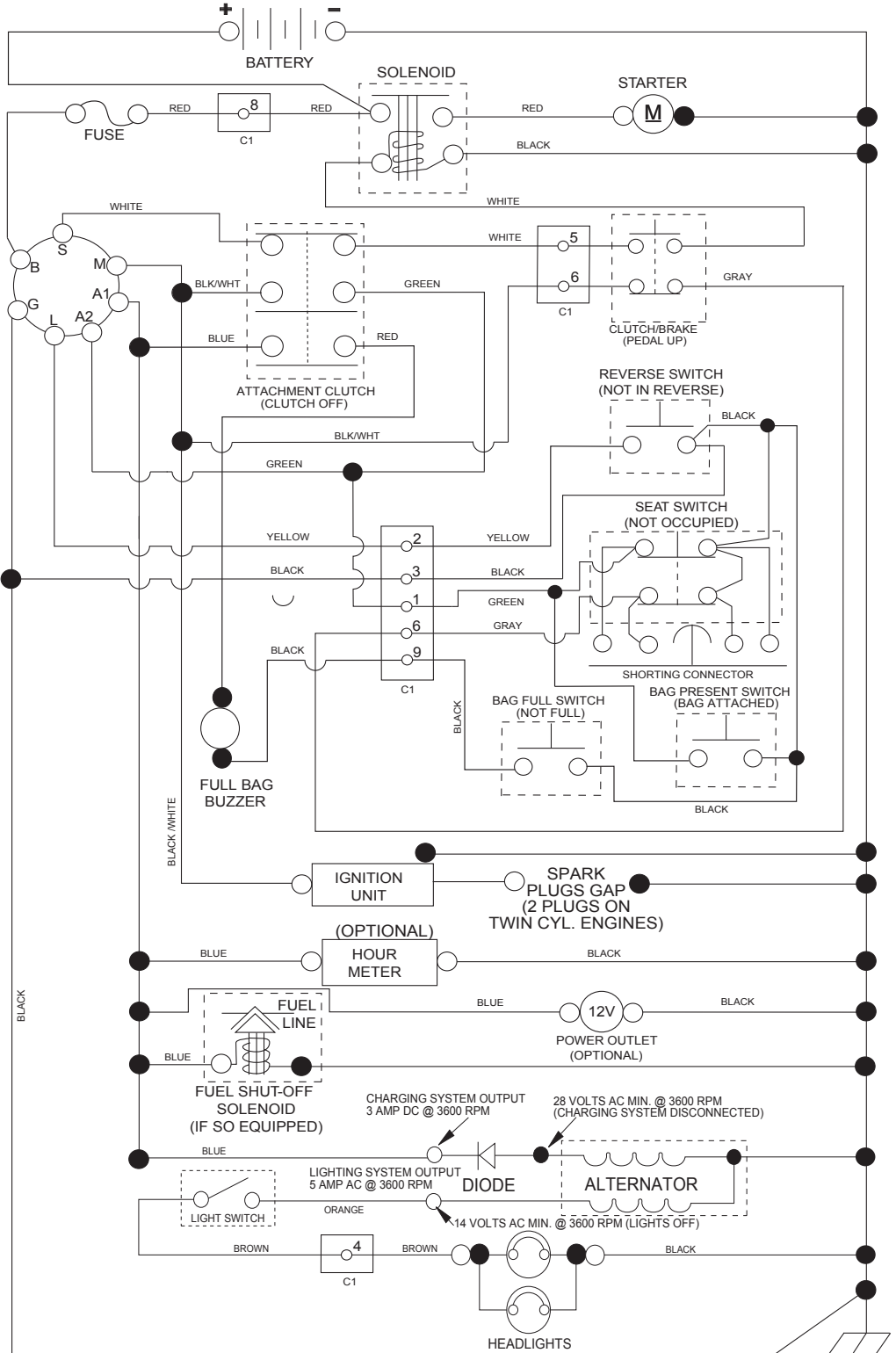

TRACTOR - MODEL NO. TC 130 (96051018800), PRODUCT NO. 960 51 01-88
ELECTRICAL 32

S02S

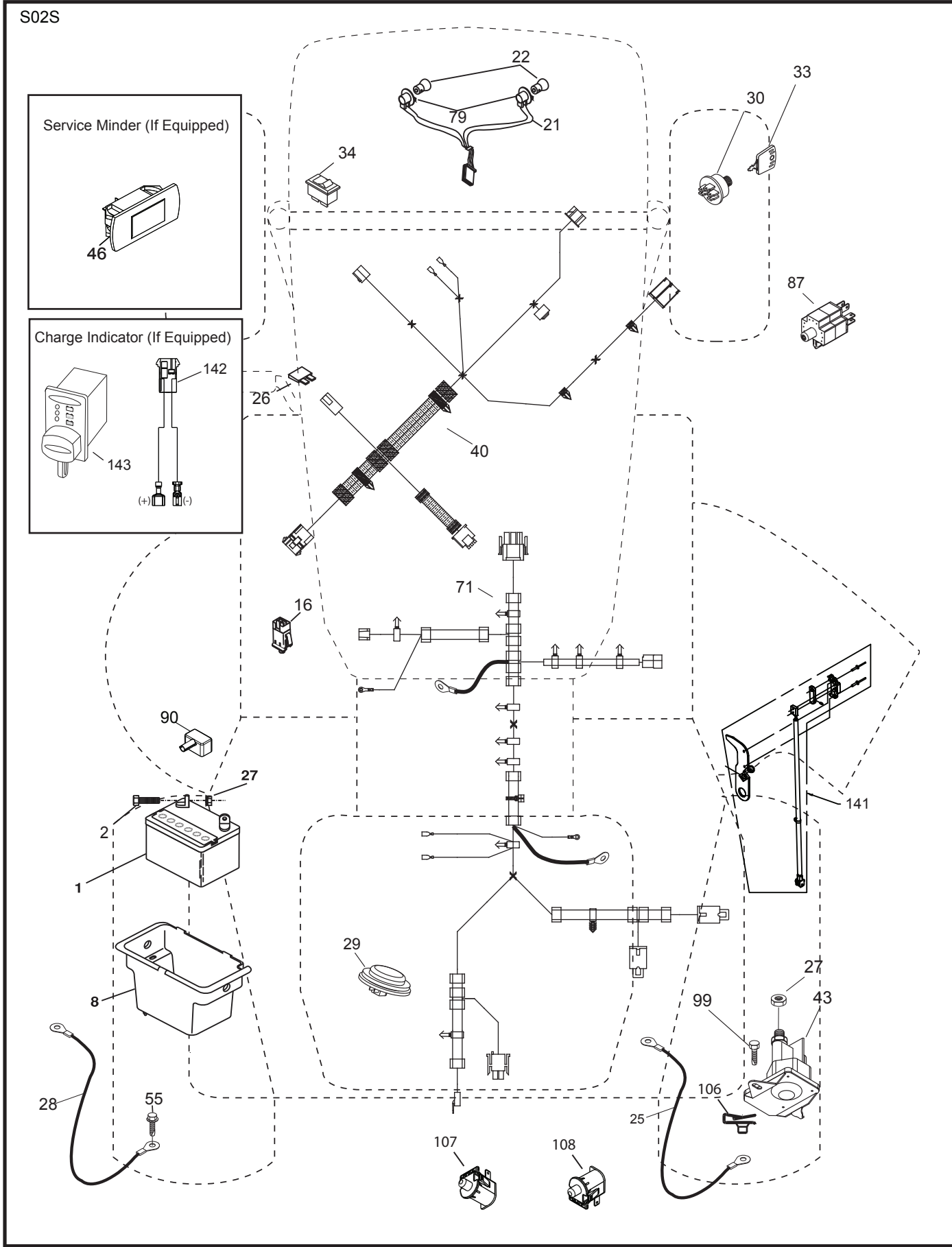
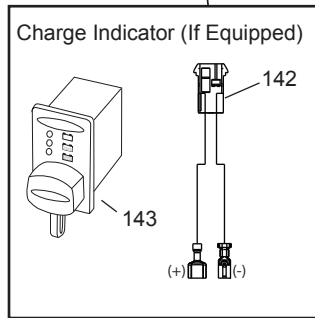
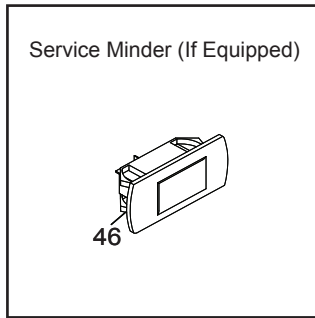

TRACTOR - MODEL NO. TC 130 (96051018800), PRODUCT NO. 960 51 01-88
ELECTRICAL 32

KEY NO.	PART NO.	DESCRIPTION
1	532 16 34-65	Battery
2	874 76 04-12	Bolt Hex Head 1/4-20 x 3/4
8	532 41 97-91	Box Battery
16	532 17 61-38	Switch Interlock Push-In
21	532 40 02-52	Harness Socket Light w/4152J
22	532 00 41-52	Bulb Light
25	532 41 66-94	Cable Starter
26	532 17 51-58	Fuse
27	596 13 36-01	Locknut Keps 1/4-20
28	532 42 16-86	Cable, Ground
29	532 40 15-45	Switch, Seat
30	532 19 33-50	Switch, Ign
33	532 41 19-35	Key/Chain
34	532 11 07-12	Switch Light/Reset
40	585 84 99-01	Harness Ign. Dash
43	582 04 28-02	Solenoid
46	594 91 91-01	Hourmeter, Srvminder, Rect
55	817 06 05-12	Screw Thdrol 5/16-18 x 3/4 TYTT
71	501 13 34-01	Harness Ign. Chassis
79	532 17 52-42	Socket Asm. Bulb
87	532 42 10-60	Switch Railmount NO-NC-NC
90	532 43 53-95	Cover Terminal
99	817 67 04-12	Screw 1/4-20 x 3/4
106	532 17 48-14	Nut Speed 1/4-20
107	532 42 10-61	Switch Snapmount No #2
108	532 42 10-62	Switch Snapmount NC
141	532 41 69-77	Kit T2 ROS
142	583 85 78-01	Charge Port Pigtail
143	532 44 80-59	Charge Port

NOTE: All component dimensions given in U.S. inches
1 inch = 25.4 mm

TRACTOR - MODEL NO. TC 130 (96051018800), PRODUCT NO. 960 51 01-88
CHASSIS AND ENCLOSURES 39

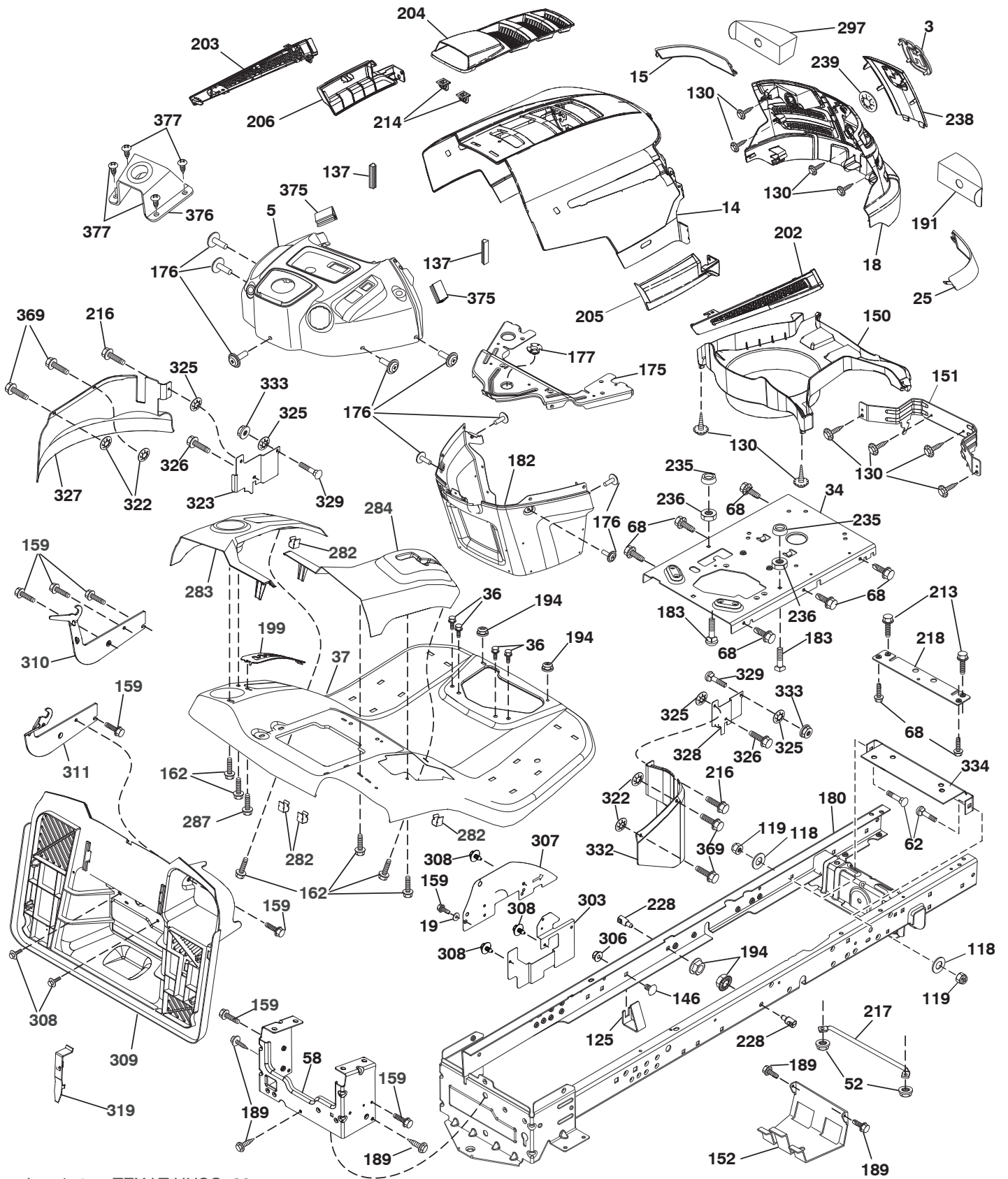

chassis-tex_TEX LT HUSQ_90

TRACTOR - MODEL NO. TC 130 (96051018800), PRODUCT NO. 960 51 01-88
CHASSIS AND ENCLOSURES 39

KEY NO.	PART NO.	DESCRIPTION	KEY NO.	PART NO.	DESCRIPTION
3	581 05 63-01	Logo	213	596 03 05-01	Bolt, Hex, Hd, 5/16-18 unc x 3/4
5	585 52 98-05	Dash	214	532 19 91-45	Clip Retainer
14	532 44 12-67	Hood	216	817 67 05-08	Screw Thdrol. 5/16-18 x 1/2
15	532 44 14-28	Lens LH	217	532 40 91-67	Rod Pivot Hood
18	532 44 13-68	Grille	218	532 19 63-95	X-Piece Hood Stop
19	596 13 32-01	Washer, 13/32 x 13/16 x 12 Ga.	228	593 82 40-01	Stud w/"D" Anti-Rotation
25	532 44 14-27	Lens RH	235	596 56 42-01	Spacer, Fender, Clr, Zn
34	580 91 09-01	Plate Engine	236	873 93 05-00	Nut Lock 5/16-18 unc
36	817 06 05-12	Screw 5/16-18 x 3/4	238	532 44 13-74	Trim
37	532 44 13-69	Fender	239	532 40 48-83	Clip Tinnerman
52	596 04 05-01	Nut, Lock Hex, Prvl, 5/16-18	282	532 41 41-10	Clip Retainer
58	532 41 22-80	Drawbar Upper	283	532 44 05-31	Console Deck Lift
62	596 72 82-01	Bolt, Carri, 3/8-16 x 1" Gr. 5	284	532 44 05-30	Console Shift
68	596 03 07-01	Screw, Hexagon, 5/16-18 x 1/2	287	817 60 04-06	Screw Hex Washhead 1/4-20 x 3/8
118	596 56 53-01	Washer, 3/8 x 0.08 in., St, Clr, Zinc	297	532 40 66-65	Insert Reflective LH
119	596 32 26-01	Nut, Crownlock, 3/8-16 unc	303	589 00 76-02	Shield Lwr LH
125	581 68 48-01	Clip Fuel Line	306	873 90 06-00	Nut Lock
130	596 32 17-01	Screw #10 x 0.750, Bos Thread	307	587 49 45-01	Shield Upper
137	532 40 75-90	Bumper Dash	308	532 17 18-77	Bolt 5/16-18 unc x 3/4
146	581 85 79-01	Bolt	309	532 43 02-46	Backplate Bagger SRD
150	532 40 66-62	Air Duct	310	532 44 54-28	Bracket Hangar Bag LH
151	532 40 78-07	Bracket Pivot	311	532 44 54-30	Bracket Hangar Bag RH
152	532 19 95-35	Shield Browning	319	532 17 46-62	Bracket Actuator Bagger
159	817 00 06-12	Screw Hexwsh Thdr 3/8-16 x 3/4	322	532 42 30-62	Palnut 1/4
162	596 13 41-01	Screw, Hex, Tap 1/4-15 x 1/2	323	532 43 14-88	Guard French
175	532 19 94-72	Crossmember	325	532 42 30-63	Palnut 5/16
176	532 40 07-76	Screw 10-24 x 5/8	326	817 06 04-10	Screw Hex
177	532 19 52-28	Bushing Steering	327	532 43 14-83	French Guard
180	532 41 46-85	Chassis	328	532 43 14-87	French Guard
182	532 40 71-76	Dash Lower	329	596 13 64-01	Bolt, Cup Head, 5/16-18 x 5/8
183	595 30 57-01	Screw Hexagon, 5/16-18 x 1-1/4	332	532 43 14-82	French Guard
189	817 00 05-12	Screw 5/16-18 x 3/4	333	596 58 37-02	Nut w/Nonmetal, Ins., Blk, Zinc
191	532 41 65-01	Insert Reflective RH	334	532 44 25-37	Bracket Engine
194	596 13 57-01	Nut, Lock Prvl., Torq, 5/16-18 x .68	369	596 43 40-01	Screw #10 x 0.500, Bos Thread
199	532 41 87-39	Plate Deck Lift	375	586 90 82-01	Dash Clip-On Bumper
202	532 44 13-42	Vent Side Hood RH	376	589 45 87-01	Mount Asm Huslt Upper Str
203	532 44 13-43	Vent Side Hood LH	377	589 45 53-01	Screw 10 x 1/2 ZN PL
204	532 44 13-75	Vent Top Hood			
205	532 44 13-44	Skirt Side RH			
206	532 44 13-45	Skirt Side LH			

NOTE: All component dimensions given in U.S. inches
1 inch = 25.4 mm

TRACTOR - MODEL NO. TC 130 (96051018800), PRODUCT NO. 960 51 01-88
DRIVE **40**

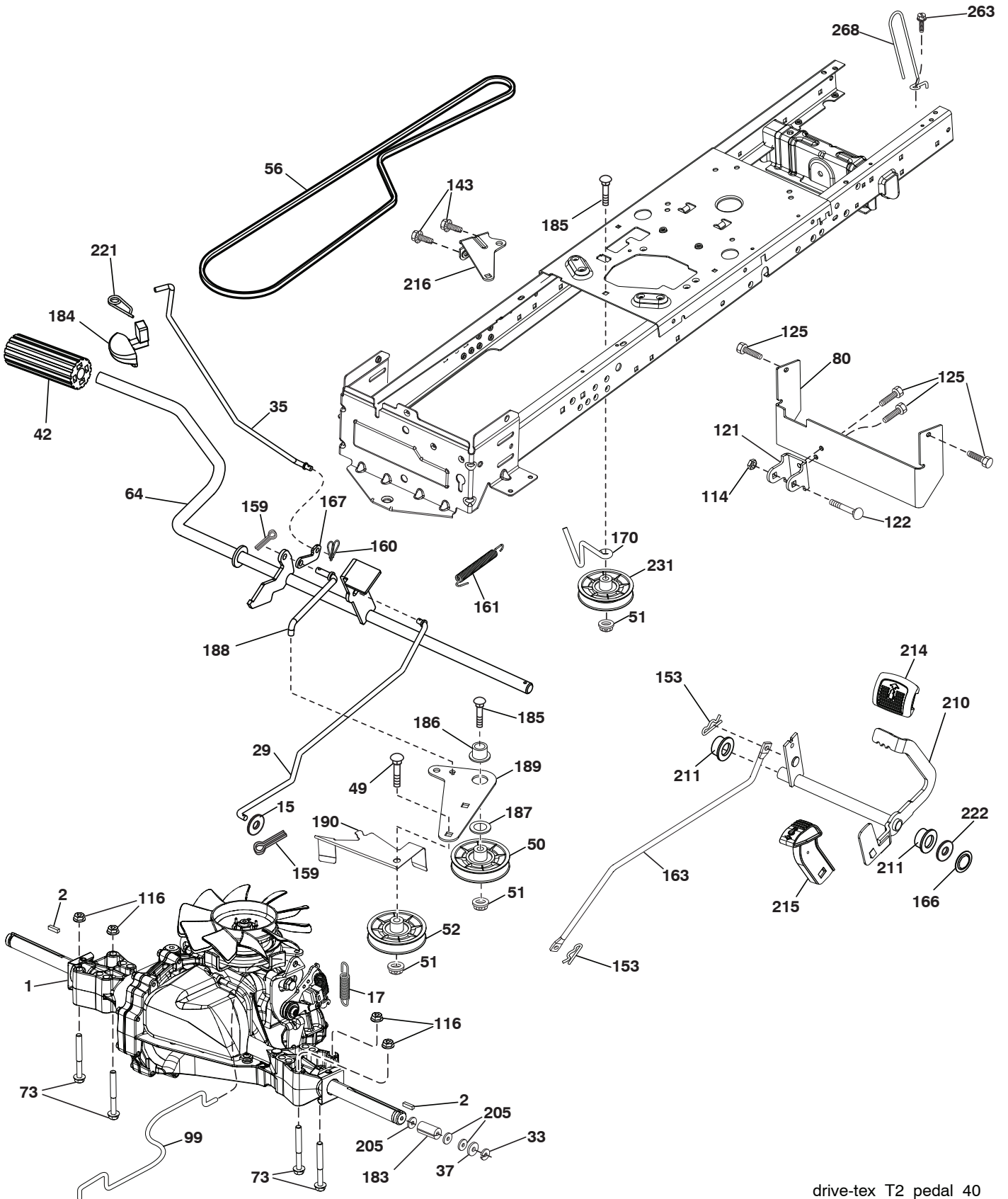

drive-tex_T2_pedal_40

**TRACTOR - MODEL NO. TC 130 (96051018800), PRODUCT NO. 960 51 01-88
DRIVE **40****

KEY NO.	PART NO.	DESCRIPTION	KEY NO.	PART NO.	DESCRIPTION
1	-----	Transaxle, Hydro Gear T2-BDBE-1X2B-18X1 (587392201) (Order parts from transaxle manufacturer.)	160	596 02 94-01	Clip, Retainer "M"
2	532 12 35-83	Key Square	161	532 10 57-09	Spring, Return, Clutch
15	596 56 53-01	Washer 3/8 x 0.08 in., St. Clr, Zinc	163	594 00 72-01	Rod Control
17	532 19 72-96	Spring, Brake	166	532 42 91-64	Nut Push .625
29	532 42 32-39	Rod, Brake	167	532 40 52-57	Latch Brake Parking
33	812 00 00-01	Ring E	170	532 41 34-30	Keeper Belt Centerspan
35	596 87 48-01	Rod, Control, Park, Txlt, Clr, Zinc	183	532 15 69-72	Spacer Axle
37	532 12 17-49	Washer 25/32 x 1-1/4 x 16 Ga.	184	532 41 14-84	Handle Parking Brake
42	532 00 88-83	Cover, Foot Pedal	185	872 11 06-22	Bolt
49	596 13 62-01	Bolt, Cup Head, 3/8-16 x 3/4	186	532 19 43-21	Spacer Retainer
50	532 19 43-27	Pulley Idler Flat	187	596 13 55-01	Washer 13/32 x 2, Clear, Zinc
51	873 90 06-00	Lock Nut 3/8-16	188	582 21 70-01	Link Clutch Ground Drive, Long
52	532 19 43-26	Idler V-Groove Offset	189	532 19 43-17	Bellcrank Ground Drive
56	592 85 53-01	V-Belt, Drive	190	532 19 43-18	Keeper Bellcrank Ground Drive
64	532 19 78-65	Shaft Asm. Pedal Brake Control	205	532 12 17-48	Washer 25/32 x 1-5/8 x 16 Ga.
73	595 31 66-01	Bolt, Hhd w/Flange 5/16-18 Gr. 5	210	532 40 09-80	Rocker Asm. Pedal Control
80	581 55 07-01	Strap Torque	211	532 12 01-83	Bearing Nylon
99	532 40 84-18	Rod Spring Bypass	214	532 42 12-63	Pedal Pad Forward
114	596 58 37-02	Nut w/Nonmetal, Ins., Blk, Zinc	215	586 60 65-02	Pedal Reverse
116	596 13 57-01	Nut, Lock, Prvl, Torq, 5/16-18 x .68	216	532 19 61-31	Bracket Pulley Idler
121	532 17 56-11	Bracket Strap Torque	221	532 40 31-87	Retainer Spring Clip Handle
122	872 01 05-20	Bolt 5/16-18 x 2.50	222	879 21 20-10	Washer 21/32 x 1-1/4 10 Ga.
125	817 00 05-12	Screw 5/16-18 x 3/4	231	532 40 72-87	Idler V-Groove
143	596 03 07-01	Screw Hexagon, 5/16-18 x 1/2	263	817 00 06-12	Screw Hexwsh THDR 3/8-16 x 3/4
153	532 00 44-97	Retainer Spring 1"	268	596 88 78-01	Guard, Muffler, B&S, Ohv
159	596 02 95-01	Pin, Cotter, 1/8 Dia. x 3/4			

NOTE: All component dimensions given in U.S. inches
1 inch = 25.4 mm

TRACTOR - MODEL NO. TC 130 (96051018800), PRODUCT NO. 960 51 01-88
ENGINE 24

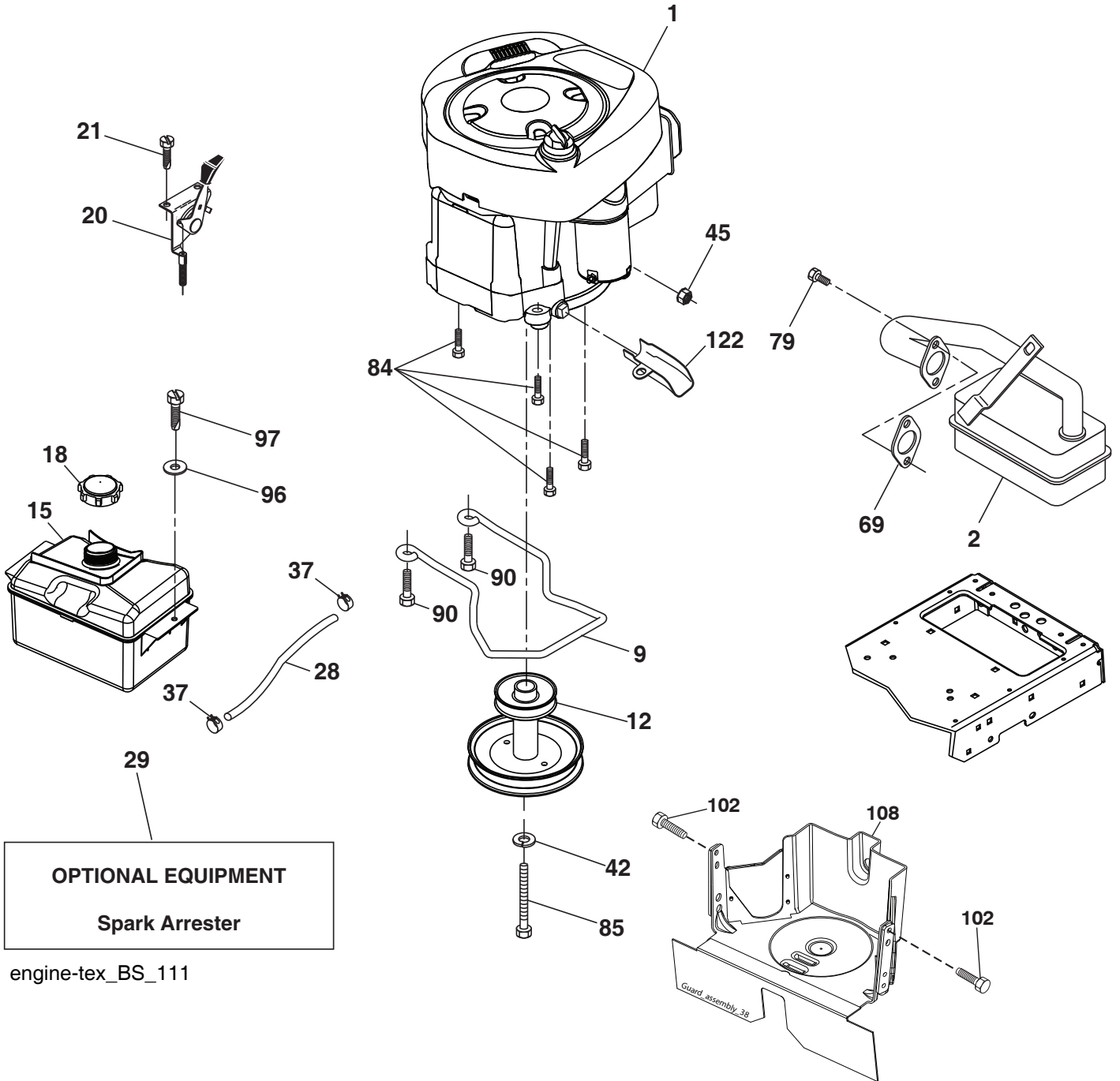

engine-tex_BS_111

**TRACTOR - MODEL NO. TC 130 (96051018800), PRODUCT NO. 960 51 01-88
ENGINE 24**

KEY NO.	PART NO.	DESCRIPTION
1	---	Engine BS Model No. 21R777-0100-B5 (597359501) (Order Parts from engine manufacturer.)
2	532 17 97-58	Muffler
9	582 54 03-02	Keeper Belt Engine
12	532 14 01-86	Pulley Engine
15	581 28 99-01	Tank Fuel 1.5
18	532 43 02-20	Cap Asm
20	587 24 26-01	Control Throttle
21	596 32 17-01	Screw #10 x 0.750, Bos Thread
28	532 13 70-40	Fuel Line
29	532 13 71-80	Spark Arrester Kit
37	532 12 34-87	Clamp Hose
42	596 23 89-01	Washer 7/16 in., Clr, Zn
45	596 13 36-01	Locknut, Keps, 1/4-20
69	532 16 52-91	Gasket
79	596 13 42-02	Screw, Socket, 5/16-18 x 1, Clr, Zn.
84	817 06 06-20	Screw 3/8-16 x 1-1/4
85	501 60 65-01	Bolt Hex 7/16-20 x 4 Gr. 5-1.5
90	817 00 06-16	Screw 3/8-16 x 1
96	596 13 53-01	Washer, Plain 9/32 x 7/8, Clr, Zn
102	817 00 05-12	Screw 5/16-18 x 3 x 4
108	587 17 95-12	Pulley Cover Engine w/SHLD 30"
122	532 42 19-22	Extension Drain Oil

NOTE: All component dimensions given in U.S. inches
1 inch = 25.4 mm

Engine Power Rating Information

The gross power rating for individual gas engine models is labeled in accordance with SAE (Society of Automotive Engineers) code J1940 (Small Engine Power & Torque Rating Procedure), and rating performance has been obtained and corrected in accordance with SAE J1995 (Revision 2002-05). Torque values are derived at 3060 RPM; horsepower values are derived at 3600 RPM. Actual gross engine power will be lower and is affected by, among other things, ambient operating conditions and engine-to-engine variability. Given both the wide array of products on which engines are placed and the variety of environmental issues applicable to operating the equipment, the gas engine will not develop the rated gross power when used in a given piece of power equipment (actual "on-site" or net power). This difference is due to a variety of factors including, but not limited to, accessories (air cleaner, exhaust, charging, cooling, carburetor, fuel pump, etc.), application limitations, ambient operating conditions (temperature, humidity, altitude), and engine-to-engine variability. Due to manufacturing and capacity limitations, Briggs & Stratton may substitute an engine of higher rated power for this Series engine.

TRACTOR - MODEL NO. TC 130 (96051018800), PRODUCT NO. 960 51 01-88
STEERING ASSEMBLY [41]

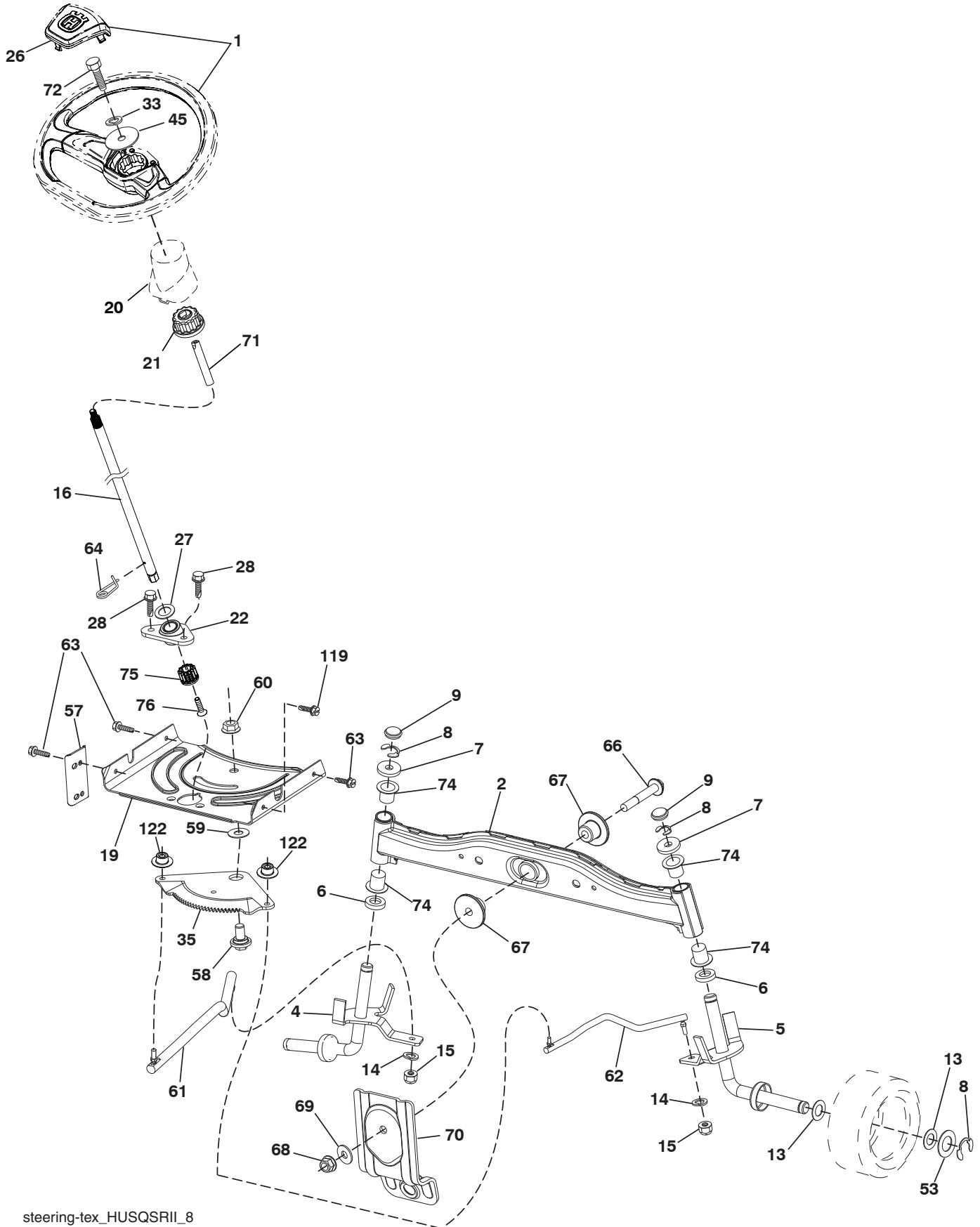

steering-tex_HUSQSR11_8

TRACTOR - MODEL NO. TC 130 (96051018800), PRODUCT NO. 960 51 01-88
STEERING ASSEMBLY 41

KEY NO.	PART NO.	DESCRIPTION
1	597 86 61-01	Wheel, Steering Kit (Includes Steering Cap)
2	532 41 81-68	Axle Asm., Front
4	532 41 68-45	Spindle Asm., LH
5	532 41 68-46	Spindle Asm., RH
6	532 00 62-66	Washer, Thrust, .75 x 1.230
7	532 12 17-48	Washer 25/32 x 1-5/8 x 16 Ga.
8	812 00 00-29	Ring, Klip #T5304-75
9	532 12 12-32	Cap, Spindle
13	532 12 17-49	Washer, 25/32 x 1-1/4 x 16 Ga.
14	596 23 87-01	Washer, Spring Lock, 381 ID x .680
15	873 54 06-00	Nut, Crown Lock 3/8-24 unf
16	585 86 92-02	Steering Shaft
19	532 19 47-29	Plate Steering
20	532 44 14-25	Boot, Steering
21	532 18 67-37	Adapter, Steering Wheel
22	585 02 98-02	Bearing
26	594 94 91-01	Cap, Steering Wheel, Husq2, Gray
27	596 93 34-01	Washer Plain
28	817 00 06-12	Screw 3/8-16 x 3/4
33	596 23 88-01	Washer, Lock, 5/16 Sqr End, Zn
35	532 19 47-32	Gear, Sector Plate
45	596 04 00-01	Washer 11/32 x 2-3/8" Clr, Zn
53	532 18 89-67	Washer Hardened .793 x 1.637 x .060
57	532 40 74-65	Bracket Upstop
58	532 19 47-47	Bolt Shoulder Sector Pivot CFM
59	532 19 47-48	Washer Thrust Sector Steering
60	873 97 10-00	Nut Flange Lock 5/8-11
61	597 04 78-02	Draglink, LH
62	597 04 79-02	Draglink, RH
63	817 00 05-12	Screw 5/16-18 x 3/4
64	532 19 98-49	Retainer Clip Spring Steering
66	871 02 07-48	Bolt Hex Fghd 7/16-14 x 3 Serr
67	532 19 47-37	Bushing PM Front Axle
68	873 90 07-00	Nut Lock Flange 7/16-14 Gr. 5
69	532 19 91-62	Washer 1.5 x .505 x .118
70	532 41 70-65	Bracket Deck Susp. Front
71	532 19 07-52	Shaft Extension Steering
72	596 03 97-01	Bolt, Hex Head, 5/16-18 unc x 4" Gr. 5
74	532 00 33-66	Bearing, Col, Strg, Blk
75	580 68 37-01	Pinion
76	580 68 36-01	Screw Head Sock
119	532 17 01-65	Bolt Shoulder 5/16-18
122	532 44 49-62	Cap Gear Sector

NOTE: All component dimensions given in U.S. inches
1 inch = 25.4 mm

TRACTOR - MODEL NO. TC 130 (96051018800), PRODUCT NO. 960 51 01-88
MOWER DECK 44

KEY NO.	PART NO.	DESCRIPTION	KEY NO.	PART NO.	DESCRIPTION
1	532 43 44-87	Kit, SVC, Weldment	33	587 81 97-01	Kit, Mandrel, Nongreaseable, Tall (includes mandrel and bolts)
2	593 82 40-01	Stud w/"D" Anti-Roation			Blade
3	596 13 57-01	Nut, Lock, Prvl, Torq, 5/16-18 x .68	35	532 41 92-74	Washer, 3/8 x 0.08 in., St. Clr, Zinc
4	532 41 76-45	Bracket Clutch Cable	37	596 56 53-01	Bolt Shoulder
5	817 00 05-10	Bolt 5/16-18	38	532 19 65-39	Screw 7/16-20 x 1 Hex
6	532 41 88-63	Arm Susp Mower Rear Srd	39	584 30 93-01	Keeper Belt Engine LH
7	596 32 17-01	Screw #10 x 0.750, Bos Thread	40	532 41 92-70	Keeper Belt Engine RH
8	532 42 02-52	Arm Idler 30"Srd	41	532 41 92-65	Screw Hexwsh THDR 3/8-16 x 3/4 BL
9	532 19 90-92	Spacer Retainer	42	817 00 06-12	Pulley Mandrel 6 5 Pd 30"
10	817 00 06-16	Screw 3/8 - 16 X 1 Smgml Tap/R Blk	43	532 41 68-77	Handle Clutch Cable
11	532 13 77-29	Screw Thd Roll 1/4 - 20 X 5/8	67	532 40 30-12	Bolt Hex Wsh Hd .313-18 x 1.19
12	532 19 94-70	Arm Brake Mower	68	584 95 39-01	Clutch Asm. Manual
13	596 13 61-01	Bolt, Cup Head, 3/8-16 x 1-1/2	70	532 40 12-46	Chute Upper SRD 30R
14	532 15 60-85	Keeper Belt Idler	72	532 41 72-36	Chute Lower SRD 30R
15	532 14 67-63	Pulley Idler V-Groove Dim 4.25	73	532 42 52-74	Pin, Hair, Cotter, 1/8 x 1-3/4
16	873 90 06-00	Nut Lock FIG 3/8 - 16 unc	74	596 91 96-01	Washout Port
17	596 13 48-01	Nut, Hex 9/16-18 x 1.010	76	532 41 55-98	Deck Guard
21	532 41 69-10	Belt Keeper Mandrel	78	532 42 25-66	Screw, Hex, Tap 1/4-15 x 1/2
22	596 48 14-01	Pulley, Idler, Flat , 3, Clear, Zinc	79	596 13 41-01	Palnut 1/4"
23	596 56 40-03	Bolt, Hex, 3/8-16 x 1.78 Clr, Zinc	80	532 42 30-62	Cable Clutch w/Spring
24	596 13 49-01	Washer, Plain, 3/8 x 7/8	152	532 43 51-11	Replacement Mower Complete
25	532 42 02-53	Keeper Belt 30"Srd	- -	532 44 09-58	
26	532 42 02-55	Cover Mandrel Asm.			
27	532 41 92-71	V-Belt Drive			
29	593 88 51-01	Rod, Hinge, 30			
32	532 40 18-72	Spring Mower Drive			

NOTE: All component dimensions given in U.S. inches
1 inch = 25.4 mm

TRACTOR - MODEL NO. TC 130 (96051018800), PRODUCT NO. 960 51 01-88
MOWER LIFT 45

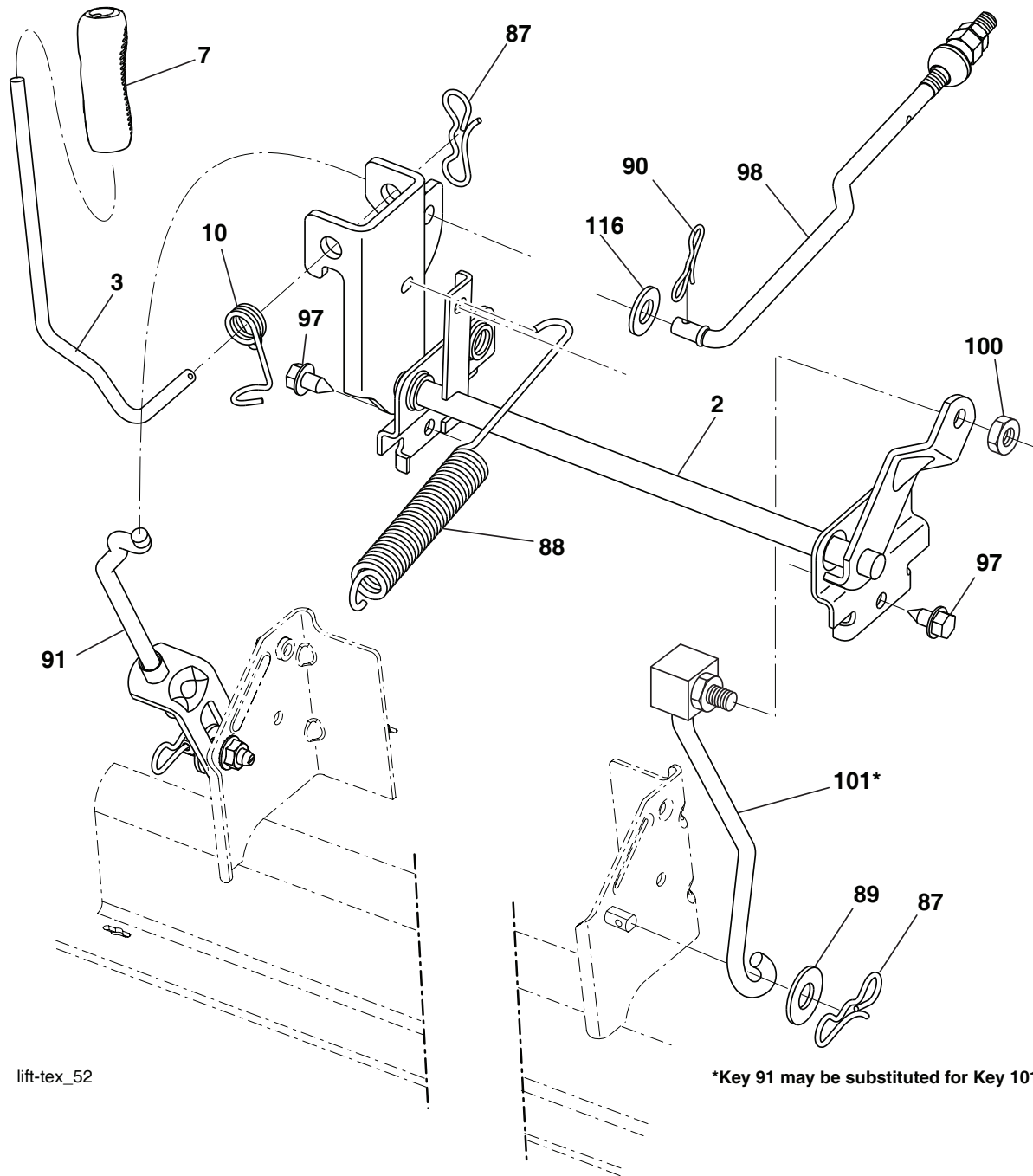

lift-tex_52

*Key 91 may be substituted for Key 101

KEY NO.	PART NO.	DESCRIPTION
2	532 42 20-27	Shaft Asm., Lift
3	594 01 80-01	Lever, Lift, Handle
7	580 96 23-01	Grip, Lever
10	532 19 63-14	Spring Torsion
87	532 19 42-09	Pin Cotter 7/16 Bow Tie Lock
88	532 41 07-10	Spring Lift Assist
89	819 19 19-12	Washer Clear
90	532 19 42-08	Pin Cotter 5/16 Bow Tie Lock
91	589 46 48-03	Link Assy, Lift, Rear

KEY NO.	PART NO.	DESCRIPTION
97	817 00 06-12	Screw 3/8-16 x 3/4
98	581 50 69-02	Link Assy, Front, Mwr, Susp
100	595 30 59-01	Nut, Hex, Locknut, 3/8-16
101	532 40 70-03	Link Asm. Lift
116	594 97 65-01	Washer, Round, 15-32 x 15/16 x .065

NOTE: All component dimensions given in U.S. inches
 1 inch = 25.4 mm

TRACTOR - MODEL NO. TC 130 (96051018800), PRODUCT NO. 960 51 01-88
SEAT ASSEMBLY 42

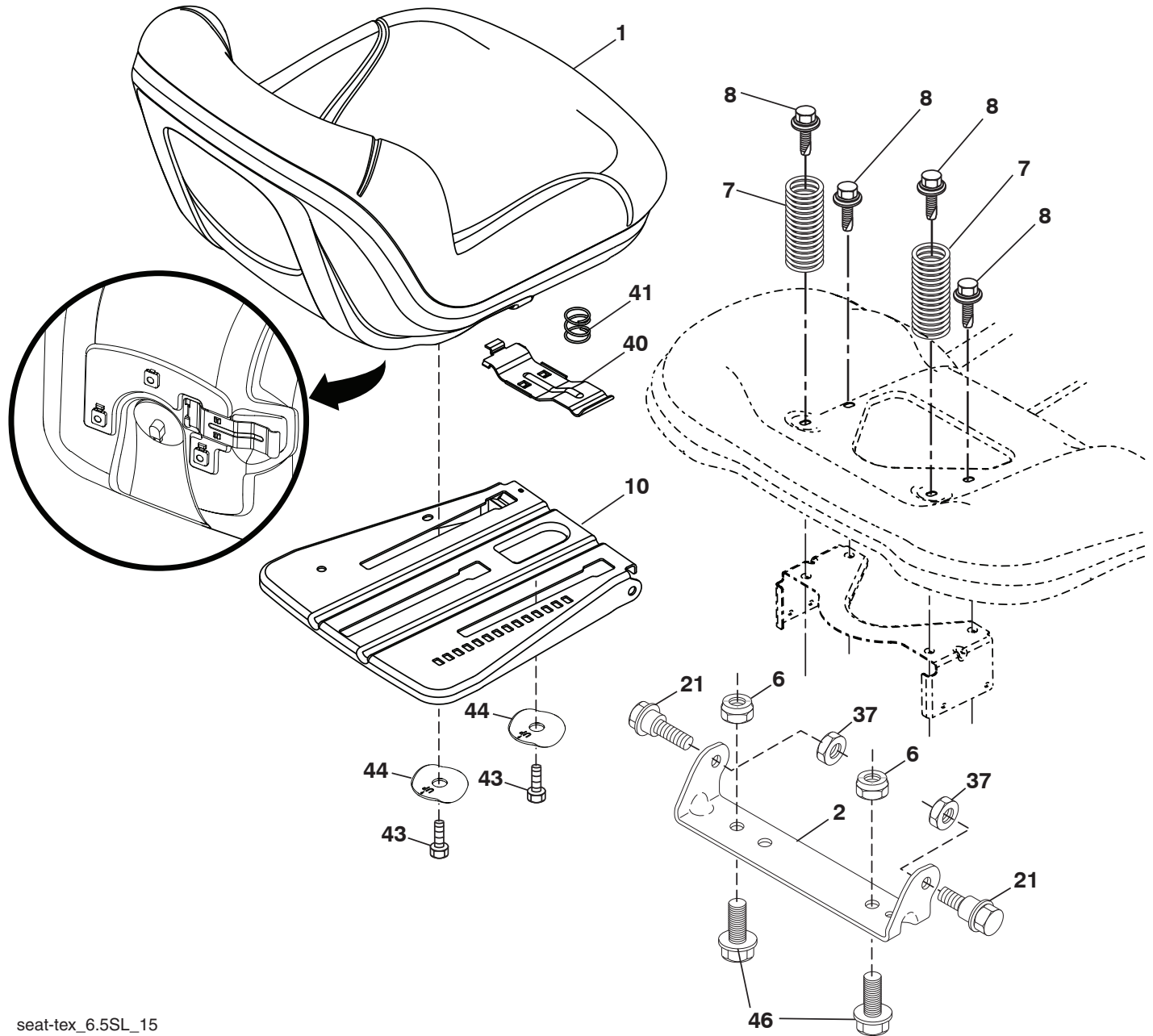

seat-tex_6.5SL_15

KEY NO.	PART NO.	DESCRIPTION
1	532 43 97-09	Seat
2	532 18 01-66	Bracket Pivot Fender
6	873 80 06-00	Nut, Lock w/Ins. 3/8-16 unc
7	589 48 35-01	Spring, Seat Cprsn
8	532 17 18-77	Bolt 5/16-18 unc x 3/4 w/Sems
10	596 65 74-02	Plate, Seat, Slide, 3 Pt., MS431
21	587 90 78-01	Bolt, Shoulder 5/16-18 x 5/8
37	596 58 37-02	Nut w/Nonmetal, Ins., Blk, Zinc

KEY NO.	PART NO.	DESCRIPTION
40	532 19 76-61	Handle Slide Seat
41	532 19 82-00	Spring Latch Seat
43	874 76 06-12	Bolt 3/8-16 x 3/4
44	501 05 18-01	Washer Wing
46	588 09 04-01	Bolt 3/8-16 x 1, 1.25 OD Wshr

NOTE: All component dimensions given in U.S. inches
 1 inch = 25.4 mm

TRACTOR - MODEL NO. TC 130 (96051018800), PRODUCT NO. 960 51 01-88
BAGGER 46

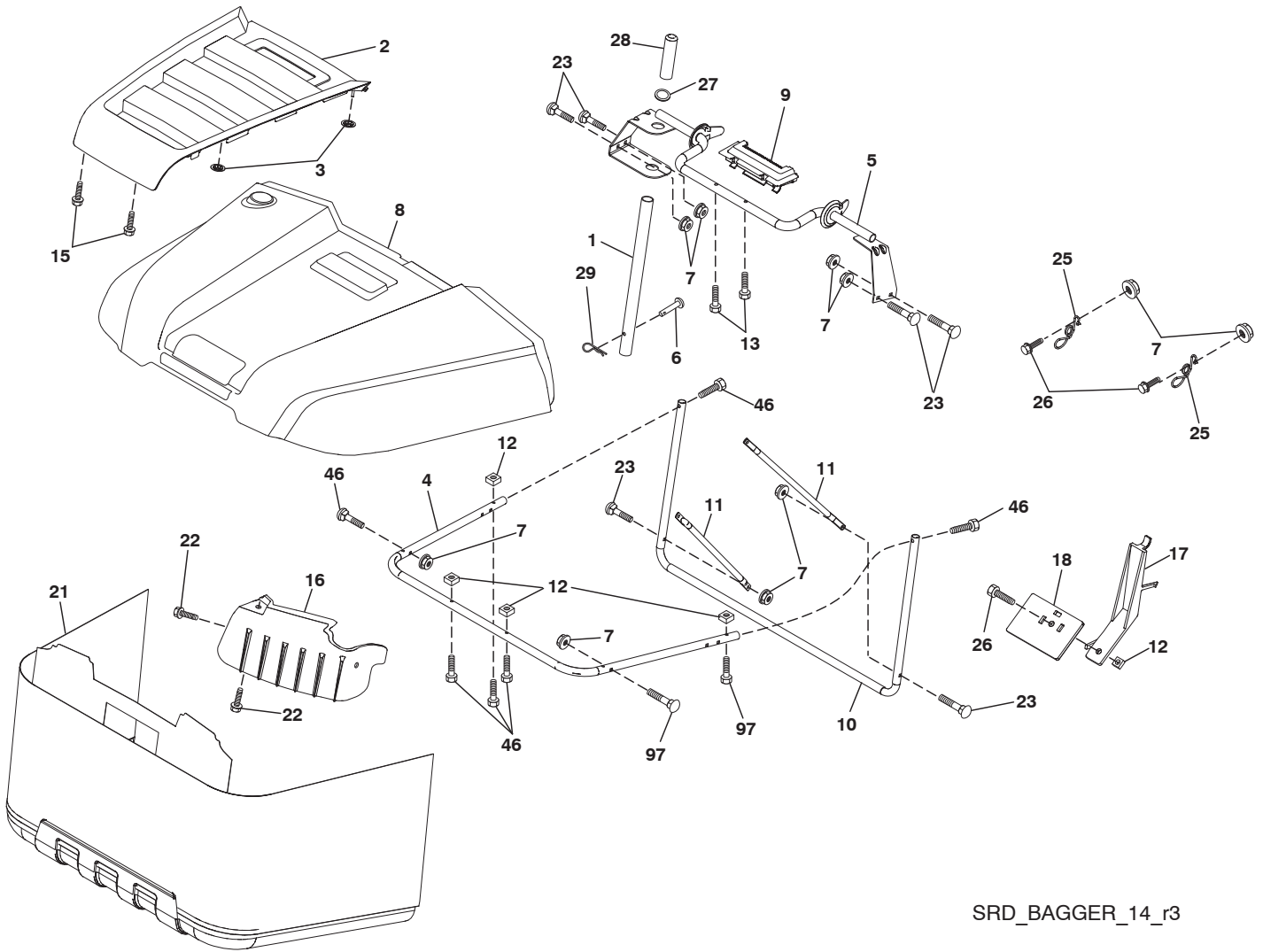

SRD_BAGGER_14_r3

**TRACTOR - MODEL NO. TC 130 (96051018800), PRODUCT NO. 960 51 01-88
BAGGER 46**

KEY NO.	PART NO.	DESCRIPTION
1	532 42 86-10	Tube Handle Bagger SRD
2	532 44 13-58	Applique
3	532 41 38-08	Nut Push
4	579 78 54-01	Frame Asm Bagger Top
5	532 41 76-32	Frame Asm Top Bagger SRD
6	532 12 68-75	Drilled Rivit
7	873 90 04-00	Nut Hex Flange 1/4-20 unc
8	532 44 12-61	Bagger Top
9	532 41 76-29	Insert Handle Bagger
10	532 41 71-90	Frame Front
11	532 41 71-88	Tubing Brace Bagger
12	532 42 17-93	Nut Square 1/4
13	532 42 17-80	Screw 1/4 x 1.150 HXWSH
15	532 42 18-01	Screw #8 Flat Head Drill Tip
16	532 42 15-66	Deflector Bagger
17	532 42 17-49	Lever Bagger Full
18	532 42 17-50	Paddle Bagger Full
21	532 42 99-81	Bag Asm SRD
22	596 13 41-01	Screw, Hex, Tap 1/4-15 x 1/2
23	872 04 04-10	Bolt Carr 1/4-20 unc x 1-1/4
25	532 42 16-14	Spring Latch Bagger
26	817 49 04-12	Screw Hex Thdrol 1/4-20 x 3/4
27	532 42 12-62	Grommet, Rubber SRD
28	532 16 57-87	Grip Handle Black
29	532 19 42-08	Pin Cotter 5/16 Bow Tie Lock
46	501 40 66-01	Screw Hx Cap 1/4-20 x 1.5
97	590 10 57-01	Screw Torx Butn HD 1/4-20-1.5"

NOTE: All component dimensions given in U.S. inches
1 inch = 25.4 mm

