

ILLUSTRATED PARTS LIST

MFG. ID NO. 96051019100

CUSTOMER CATALOG NO. TC 242T

PRODUCT NO. 960 51 01-91

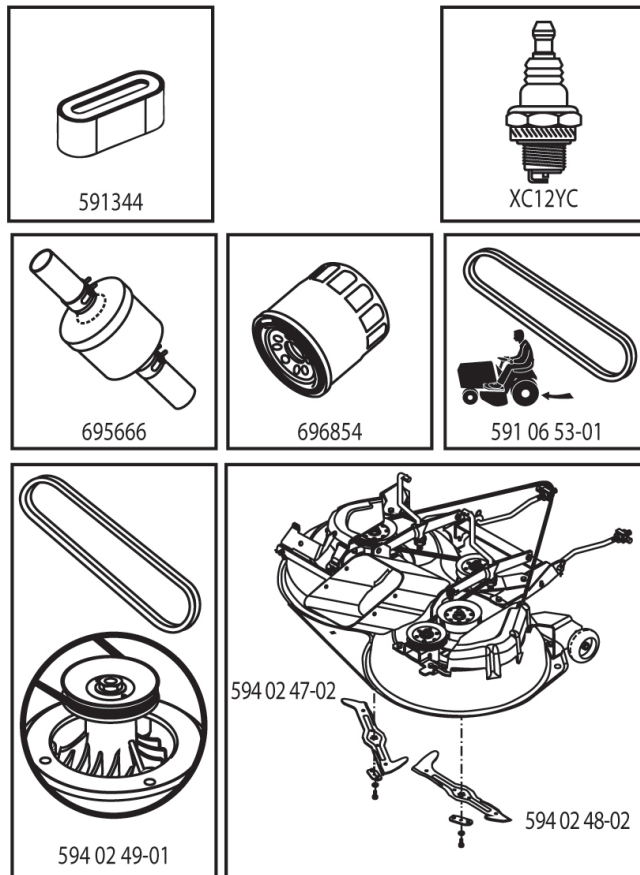

47

598374701

**TRACTOR - MODEL NO. TC 242T (96051019100), PRODUCT NO. 960 51 01-91
DECALS 27**

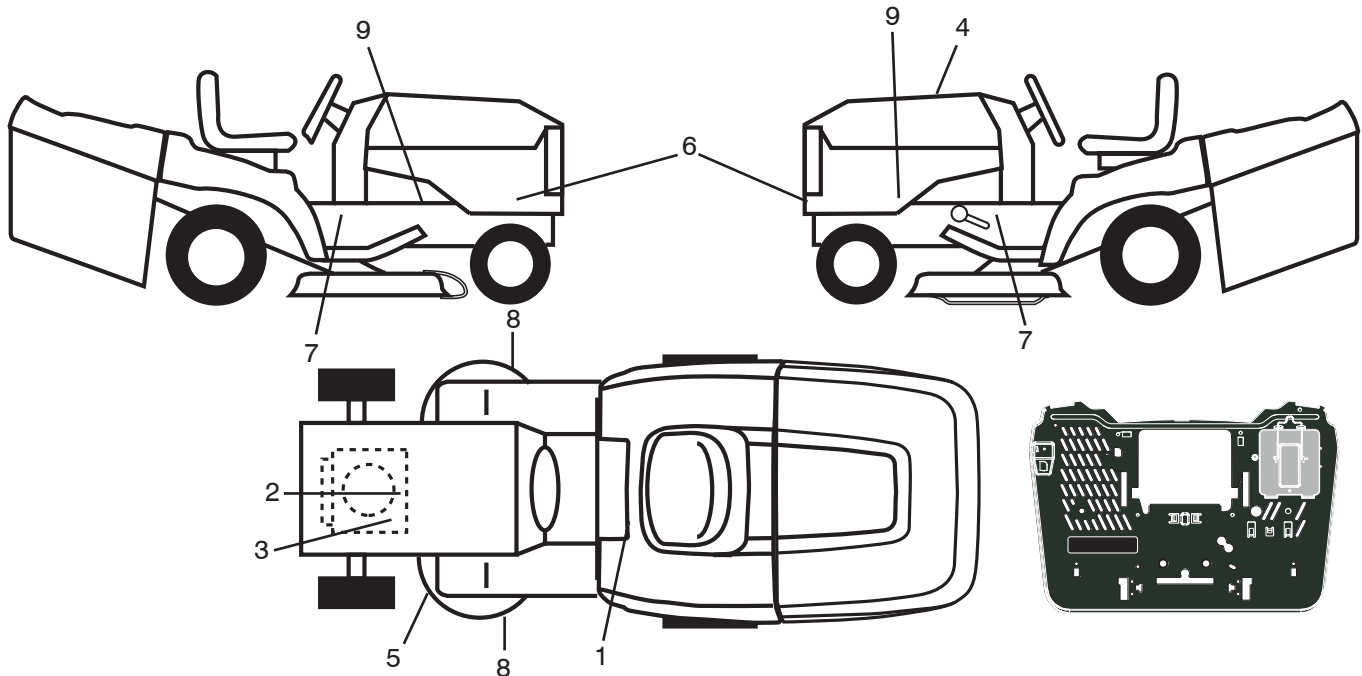

KEY NO.	PART NO.	DESCRIPTION
1	586 35 06-01	Decal, Warning
2	581 57 97-01	Decal, Warning Eng. Sym.
3	587 38 53-01	Decal, Engine
4	598 37 47-01	Decal, Replacement
5	597 47 53-01	Decal, Deck Belt
6	597 90 89-01	Decal, Side Panel
7	581 57 98-01	Decal, Warning
8	581 57 91-01	Decal, Mower Cut Finger Symbol
9	581 57 96-01	Decal, Chassis Hot Muffler
--	532 44 46-19	Decal, Bypass

KEY NO.	PART NO.	DESCRIPTION
--	532 44 14-09	Pad Footrest LH
--	532 44 14-10	Pad Footrest RH
--	532 44 54-93	Decal, Backplate Warning
--	114 18 99-20	Manual Operator's (Euro)
--	114 19 00-10	Manual Operator's (Scan)
--	114 19 01-50	Manual Operator's (E-Bloc)
--	114 19 02-40	Manual Operator's (Baltic)
--	114 19 03-76	Manual Operator's (Turkish)
--	114 19 04-53	Manual Operator's (Ukrainian)

WHEELS AND TIRES

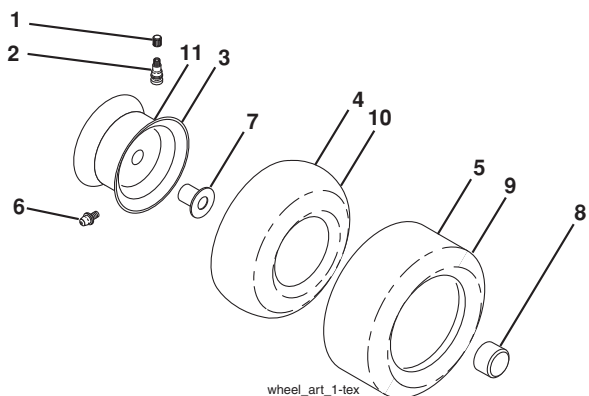

KEY NO.	PART NO.	DESCRIPTION
1	532 05 91-92	Cap Valve Tire
2	532 06 51-39	Stem Valve
3	532 13 83-36	Rim Front
4	532 05 99-04	Tube Front (Service Item Only)
5	532 10 62-22	Tire Front 15 x 6-6
6	532 00 02-78	Fitting Grease (Front Wheel Only)
7	532 00 90-40	Bearing Flange (Front Wheel Only)
8	532 17 50-39	Cap Axle Blk 1 50 x 1 00
9	532 12 46-35	Tire Rear 18 x 8.5-8
10	532 00 71-52	Tube Rear (Service Item Only)
11	532 13 83-37	Rim Asm 8" Rear
--	532 14 43-34	Sealant, Tire (10 oz. Tube)

NOTE: All component dimensions given in U.S. inches
1 inch = 25.4 mm

TRACTOR - MODEL NO. TC 242T (96051019100), PRODUCT NO. 960 51 01-91

SCHEMATIC 38

SCH17

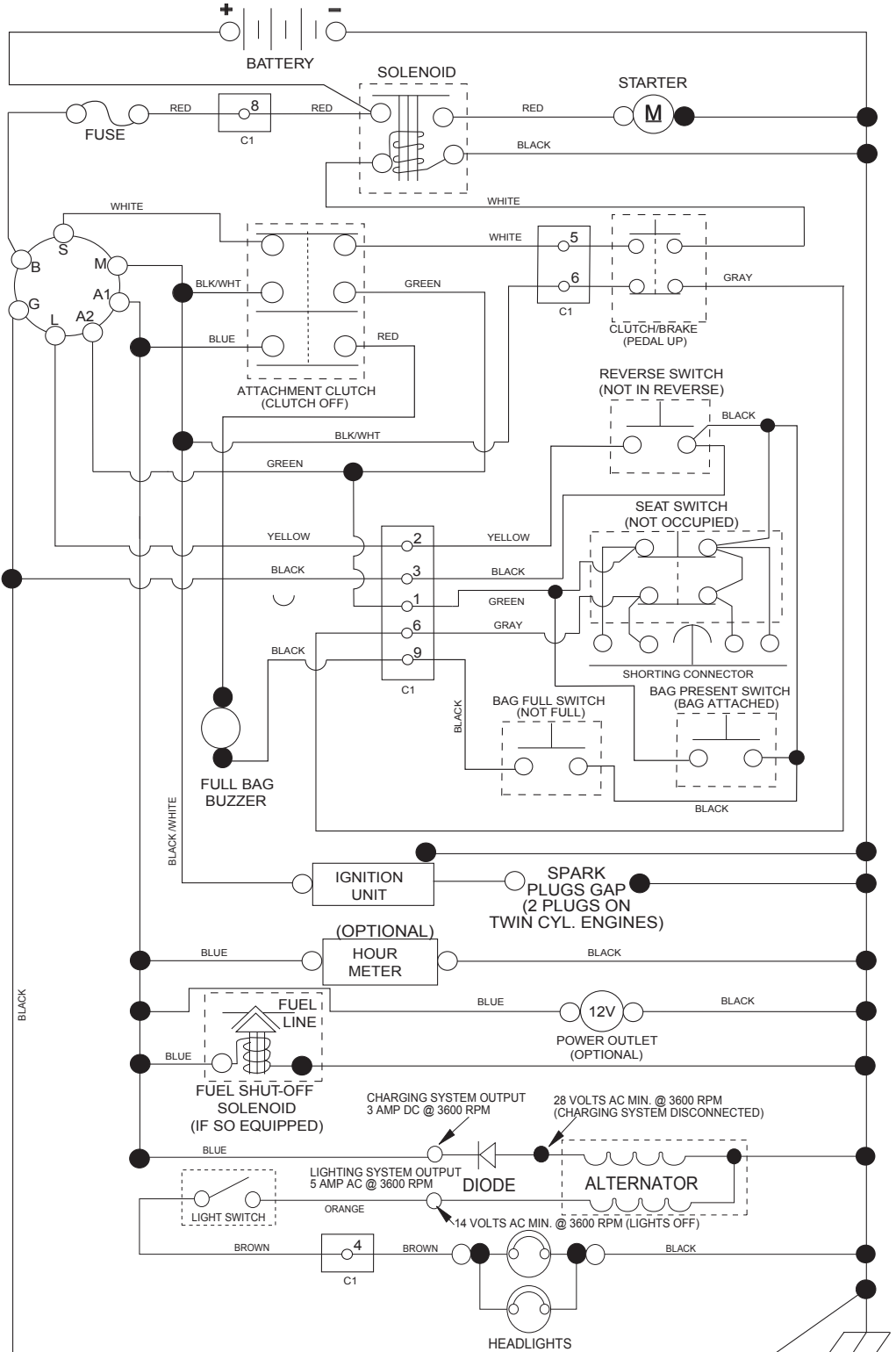

NOTE
YOUR TRACTOR IS EQUIPPED WITH A SPECIAL ALTERNATOR SYSTEM. THE LIGHTS ARE NOT CONNECTED TO THE BATTERY, BUT HAVE THEIR OWN ELECTRICAL SOURCE. BECAUSE OF THIS, THE BRIGHTNESS OF THE LIGHTS WILL CHANGE WITH ENGINE SPEED. AT IDLE THE LIGHTS WILL DIM. AS THE ENGINE SPEED IS INCREASED, THE LIGHTS WILL BECOME THEIR BRIGHTEST.

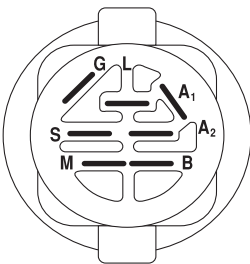

IGNITION SWITCH

POSITION	CIRCUIT	"MAKE"
OFF	M+G+A1	
RUN/OVERRIDE	B+A1	
RUN	B+A1	L+A2
START	B + S + A1	

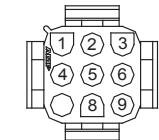

CHASSIS HARNESS CONNECTOR (C1) (MATING SIDE)

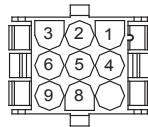

DASH HARNESS CONNECTOR (C1) (MATING SIDE)

WIRING INSULATED CLIPS
NOTE: IF WIRING INSULATED CLIPS WERE REMOVED FOR SERVICING OF UNIT, THEY SHOULD BE RE-INSTALLED TO PROPERLY SECURE YOUR WIRING.

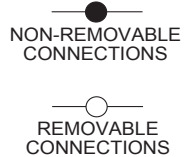

TRACTOR - MODEL NO. TC 242T (96051019100), PRODUCT NO. 960 51 01-91
ELECTRICAL 32

TC03SM

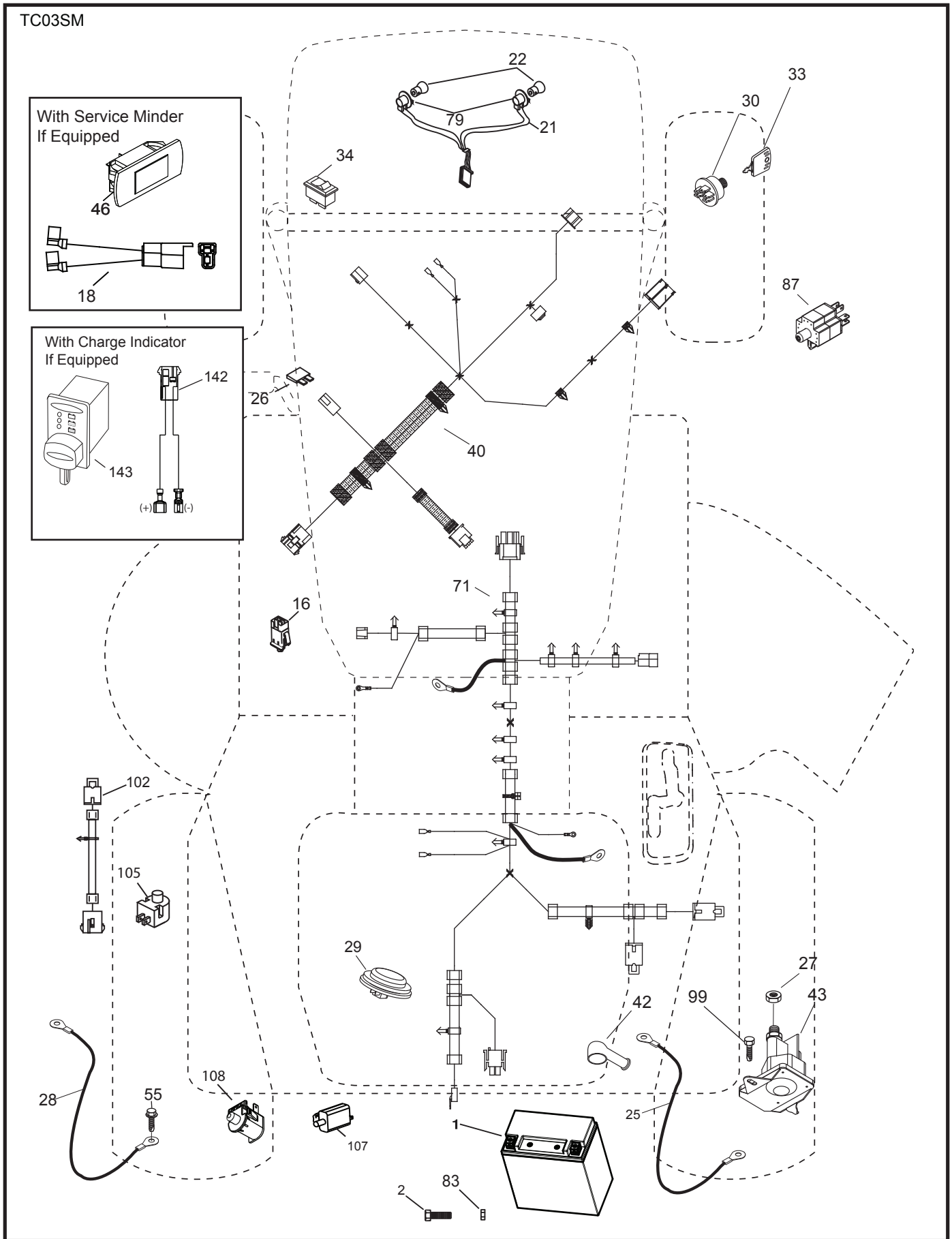

**TRACTOR - MODEL NO. TC 242T (96051019100), PRODUCT NO. 960 51 01-91
ELECTRICAL 32**

KEY NO.	PART NO.	DESCRIPTION
1	532 43 71-57	Battery
2	596 32 01-01	Bolt, Hex. M6 x 1 x 12.4 mm 8.8
16	532 17 61-38	Switch Interlock Push-In
21	532 40 02-52	Harness Light w/4152J
22	532 00 41-52	Bulb Light
25	589 32 37-01	Cable Starter
26	532 17 51-58	Fuse
27	596 13 36-01	Locknut, KEPS, 1/4-20
28	589 32 36-01	Cable, Ground
29	532 19 27-49	Switch, Seat
30	532 19 33-50	Switch, Ign
33	532 41 19-35	Key/Chain
34	532 11 07-12	Switch Light/Reset
40	532 42 10-02	Harness Ign. Dash
42	532 13 15-63	Cover Terminal Red
43	582 04 28-02	Solenoid w/Brass Plunger, AN
46	594 91 91-01	Hourmeter, SRVCMNOR
55	817 06 05-12	Screw Thdrol 5/16-18 x 3/4 TYTT
71	587 26 87-01	Harness Ignition Chassis
79	532 17 52-42	Socket Asm. Bulb
83	594 08 65-01	Nut, Square, M6 x 1
87	532 42 10-60	Switch
99	817 00 05-12	Screw 5/16-18 x 3/4
102	532 44 12-62	Harness Jumper
105	532 40 75-68	Switch Reverse
107	532 18 03-79	Switch Full Bagger
108	589 50 03-01	Switch Snapmount

NOTE: All component dimensions given in U.S. inches
1 inch = 25.4 mm

TRACTOR - MODEL NO. TC 242T (96051019100), PRODUCT NO. 960 51 01-91
CHASSIS AND ENCLOSURES 39

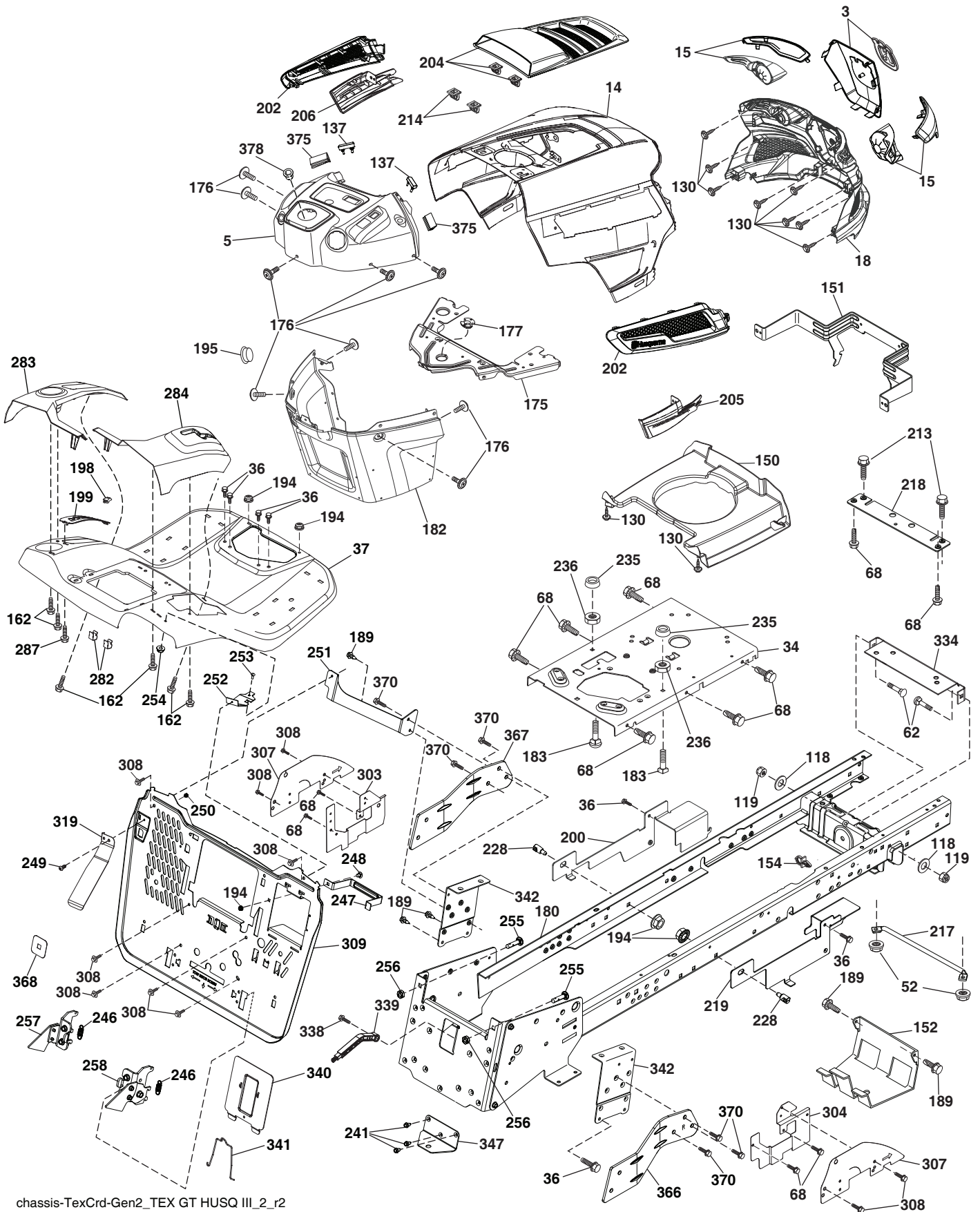

chassis-TexCrd-Gen2_TEX GT HUSQ III_2_r2

**TRACTOR - MODEL NO. TC 242T (96051019100), PRODUCT NO. 960 51 01-91
CHASSIS AND ENCLOSURES 39**

KEY PART NO. NO.	DESCRIPTION	KEY PART NO. NO.	DESCRIPTION
3	597 68 82-01	228	593 82 40-01
	Kit, Grille Applique, (includes applique cover and emblem badge)	235	596 56 42-01
5	590 74 88-23	236	873 93 05-00
14	532 44 11-77	241	593 33 76-01
15	597 86 78-01	246	591 44 90-01
	Incandescent headlight kit (includes LH/RH lens and LH/RH housing)	247	582 55 26-02
		248	872 11 05-04
18	597 40 71-01	249	586 93 60-01
34	593 94 44-02	250	596 04 08-01
36	817 06 05-12	251	589 31 89-04
37	532 44 14-19	252	581 99 22-04
52	596 04 05-01	253	596 23 84-01
62	596 72 82-01	254	873 90 04-00
68	596 03 07-01	255	589 39 22-03
118	596 56 53-01	256	532 19 70-33
119	596 32 26-01	257	589 74 66-02
130	596 32 17-01	258	589 74 67-02
137	532 40 75-90	282	532 41 41-10
150	532 43 97-74	283	532 44 72-12
151	532 43 66-70	284	532 44 72-20
152	532 19 95-35	287	817 60 04-06
154	532 14 50-06	303	597 72 39-02
162	596 13 41-01	304	597 72 40-02
175	590 60 77-02	307	587 49 45-01
176	532 40 07-76	308	532 17 18-77
177	532 19 52-28	309	582 55 25-02
180	593 89 88-01	319	581 31 39-07
182	586 73 86-02	334	532 44 25-37
183	595 30 57-01	338	594 09 39-01
189	817 00 05-12	339	532 43 66-41
194	596 13 57-01	340	582 55 27-02
195	532 40 41-37	341	582 06 08-01
198	532 44 15-52	342	582 82 68-02
199	532 41 87-39	347	532 44 28-87
200	594 02 62-02	366	581 31 46-02
202	597 86 77-01	367	581 31 45-02
	Kit, Side Vents, LH/RH (includes LH/RH side vents)	368	581 42 48-01
204	597 40 80-01	370	817 12 06-16
	Kit, Top Vent (includes top vent and clip retainers)	375	586 90 82-01
205	532 43 97-30	378	590 84 98-01
206	532 43 97-29	--	597 33 48-01
213	596 03 05-01		
214	532 19 91-45		
217	532 40 91-67		
218	532 19 63-95		
219	594 02 63-02		

NOTE: All component dimensions given in U.S. inches
1 inch = 25.4 mm

**TRACTOR - MODEL NO. TC 242T (96051019100), PRODUCT NO. 960 51 01-91
DRIVE **40****

KEY NO.	PART NO.	DESCRIPTION	KEY NO.	PART NO.	DESCRIPTION
1	---	Transaxle, Tufftorq K46DF (446488) (Order parts from trans-axle manufacturer.)	186	532 19 43-21	Spacer Retainer
2	532 12 35-83	Key Square	188	582 21 70-01	Link Clutch
6	532 12 40-28	Bushing Snap	189	532 43 36-11	Bellcrank Ground Drive
17	532 43 62-27	Spring Brake K46	195	580 45 69-01	Bracket Rod Brake CRD Tex
27	596 24 10-01	Screw, Hex, Thread Roll, 5-16 x 18	203	596 20 41-01	Washer, 1 1/32 x 1 1/16 x 14
29	532 44 27-95	Rod, Brake	205	532 12 17-48	Washer 25/32 x 1-5/8 x 16 Ga.
30	596 14 02-01	Washer, 406ID x OD x .065	210	532 40 09-80	Rocker Asm. Pedal Control
33	812 00 00-01	Ring E	211	532 12 01-83	Bearing Nylon
35	583 86 45-02	Rod, BRK, Parking, GT Husq	214	532 42 12-63	Pedal Forward
37	532 18 89-67	Washer Harden .793 x 1.063 x .060	215	586 60 65-02	Pedal Reverse
38	532 16 96-13	Nyliner Bushing	221	532 40 31-87	Retainer Spring Clip Handle
42	532 00 88-83	Cover, Foot Pedal	222	879 21 20-10	Washer 21/32 x 1-1/4 10 Ga.
49	596 13 62-01	Bolt, Cup, Head, 3/8-16 x 3/4	226	532 40 15-64	Bracket Strap Torque
50	532 19 43-27	Idler Flat	227	596 13 59-01	Bolt, Hex, 5/16-18 x 3/4, CLR, Zinc
51	873 90 06-00	Lock Nut 3/8-16	279	593 89 84-01	Link & Stud-Link, SUBASM
52	532 19 43-26	Idler V-Groove	280	596 03 99-01	Washer, Plain, 11/32 x 5/8, CLR
56	591 06 53-01	V-Belt, Drive	309	532 16 55-81	Plate Fstnr Cross Shf
61	532 44 51-51	Pulley Transaxle K46	311	532 16 98-45	Washer Nylon
64	532 19 78-65	Shaft Asm. Pedal Brake Control	312	532 16 56-14	Hub Tapered
73	595 31 66-01	Bolt, HHD w/Flange, 5/16-18 Gr. 5	313	596 04 07-01	Bolt, Hex, 1/4-20 x 1
90	532 44 36-05	Keeper Belt Clutching	314	532 44 47-13	Keeper Belt
99	532 44 39-47	Rod Spring Bypass	315	817 58 05-20	Screw Thdrol 5/16-18 x 4.25
103	596 43 63-01	Nut, Hex, 5/16-18 x 0.577" Gr.5, Zn	335	532 19 95-34	Pulley V-Idler
116	596 13 57-01	Nut, Lock, PRVL, TORQ, 5/16-18x.68	336	587 25 96-02	Bolt, 5/16-18 x 1-3/4, Flanged
125	817 00 05-12	Screw 5/16-18 x 3/4	339	532 43 68-67	Strap Torque K46 CRD Tex
140	596 02 98-01	Spring, Lock, Washer, Square Ends	342	532 18 26-82	Keeper Belt 2.5" STL V-Idlr CRD
143	596 03 07-01	Screw, Hexagon, 5/16-18 x 1/2	343	594 94 44-01	Nut, Hexagon, Flange, 5/16-18
159	596 02 95-01	Pin, Cotter, 1/8 dia x 3/4	351	532 43 69-98	Bracket 97 CRD Deck Sway
160	596 02 94-01	Clip, Retainer "M"	352	532 43 56-45	Bracket Idler CRD Tex
161	532 10 57-09	Spring, Return, Clutch	355	532 43 56-69	Bracket
163	594 08 41-02	Rod, CNTRL, Shift Pedal	359	596 56 40-02	Bolt, HHD, 3/8-16 x 0.655 CLR, ZN
166	532 42 91-64	Nut Push	360	532 44 47-14	Nut 5/16-24 unf
167	532 40 52-57	Latch Brake Parking	362	532 43 68-12	Idler Flat
175	532 42 93-59	Shaft Asm Crossshift Rear CRD	363	532 44 27-80	Spacer .343 x .63 x .62
177	587 22 53-01	Pin, Cotter, Locking, Bowtie, 1 In.	364	532 44 30-32	Bracket Idler CRD Tex
183	532 13 70-57	Spacer Axle	372	582 65 49-01	Keeper Belt Transaxle
184	587 65 37-01	Handle Parking Brake			
185	872 11 06-22	Bolt 3/8-16 unc x 2-3/4 Gr. 5			

NOTE: All component dimensions given in U.S. inches
1 inch = 25.4 mm

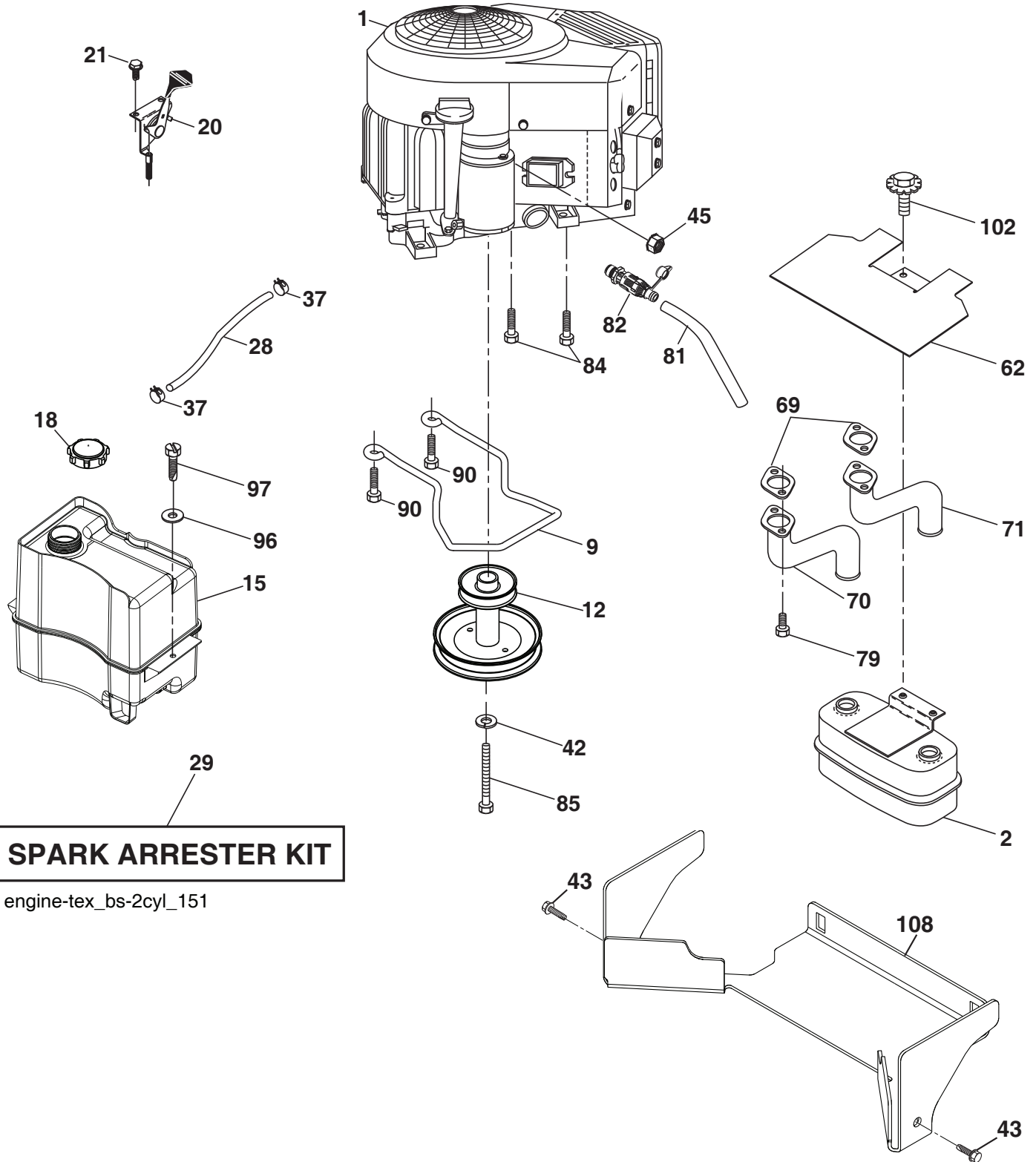

SPARK ARRESTER KIT

engine-tex_bs-2cyl_151

**TRACTOR - MODEL NO. TC 242T (96051019100), PRODUCT NO. 960 51 01-91
ENGINE 24**

KEY NO.	PART NO.	DESCRIPTION
1	-----	Engine B&S Model No. 40N777-0009-B5 (597818301) (Order parts from engine manufacturer.)
2	589 81 87-01	Muffler
9	501 83 26-02	Keeper Belt Engine
12	586 72 89-01	Pulley Engine
15	581 29 01-01	Tank Fuel
18	532 43 02-20	Fuel Cap
20	587 24 25-01	Control Throttle
21	596 32 17-01	Screw, #10 x .075, BOS, Thread
28	532 13 70-40	Fuel Line
29	532 13 71-80	Spark Arrester Kit
37	532 12 34-87	Clamp Hose
42	596 23 89-01	Washer 7/16in, CLR, ZN
43	817 06 05-12	Screw 5/16-18 x 3/4 Thdrol
45	596 13 36-01	Locknut, KEPS, 1/4-20
62	532 43 40-17	Shield Heat Muffler
69	532 16 53-91	Gasket
70	581 88 11-01	Tube Exhaust LH
71	581 88 10-01	Tube Exhaust RH
79	596 13 42-02	Screw, Socket, 5/16-18 x 1, CLR, Zn
81	532 14 84-56	Tube Drain Oil Easy
82	532 42 82-87	Valve Oil Drain
84	817 06 06-20	Screw
85	501 60 65-01	Bolt Hex 7/16-20 x 4 x Gr. 5-1.5 Thr
90	817 00 06-16	Screw 3/8-16 x 1
96	596 13 53-01	Washer, Plain, 9/32 X 7/8, Clr, Zn
97	817 67 04-12	Screw 1/4-20 x 3/4
102	817 00 05-12	Screw 5/16-18 x 3/4
108	594 02 64-02	Shield, Clutch

NOTE: All component dimensions given in U.S. inches
1 inch = 25.4 mm

TRACTOR - MODEL NO. TC 242T (96051019100), PRODUCT NO. 960 51 01-91
STEERING ASSEMBLY 41

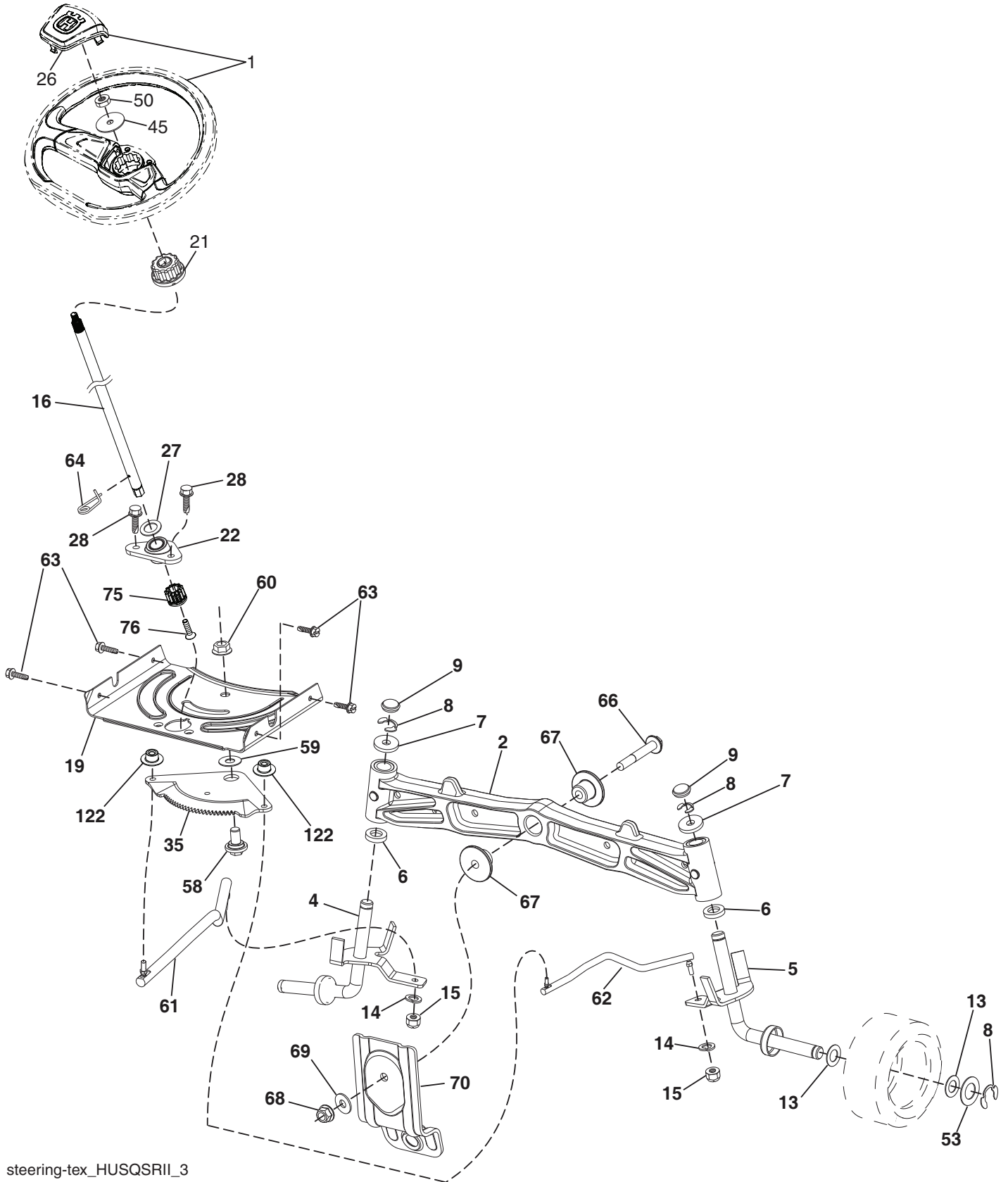

steering-tex_HUSQSR11_3

**TRACTOR - MODEL NO. TC 242T (96051019100), PRODUCT NO. 960 51 01-91
STEERING ASSEMBLY **41****

KEY NO.	PART NO.	DESCRIPTION
1	597 86 61-01	Wheel, Steering, Kit (includes steering wheel and cap)
2	532 19 59-68	Axle Asm.
4	532 40 30-87	Spindle, LH
5	532 40 30-88	Spindle, RH
6	532 00 62-66	Washer Thrust 0.75 x 1.23
7	532 12 17-48	Washer 25/32 x 1-5/8 x 16 Ga.
8	812 00 00-29	Ring, Klip #T5304-75
9	532 12 12-32	Cap, Spindle
13	532 12 17-49	Washer 25/32 x 1-1/4 x 16 Ga.
14	596 23 87-01	Washer, Spring, Lock, 381ID x .680
15	873 54 06-00	Nut, Crown Lock 3/8-24 unf
16	587 01 60-02	Steering Shaft
19	532 19 47-29	Plate Steering
21	586 84 02-01	Adapter Wheel Steering
22	585 02 98-02	Bearing
26	594 94 91-01	Cap, Wheel, Steering
27	596 93 34-01	Washer, Plain
28	817 00 06-12	Screw 3/8-16 x 3/4
35	532 19 47-32	Gear, Sector Plate
45	587 01 64-01	Washer 3/8 ID 2-3/8 OD 12 Ga. PLTD
50	873 90 06-00	Nut Lock Flg 3/8-16 unc
53	532 18 89-67	Washer Hardened .793 x 1.637 x .060
58	532 19 47-47	Bolt Shoulder Sector Pivot CFM
59	532 19 47-48	Washer Thrust Sector Steering
60	873 97 10-00	Nut Flange Lock 5/8-11
61	597 04 78-02	Linkage Asm., Draglink, LH
62	597 04 79-02	Linkage Asm., Draglink, RH
63	817 00 05-12	Screw 5/16-18 x 3/4
64	532 19 98-49	Retainer Clip Spring Steering
66	871 02 07-48	Bolt Hex Fghd 7/16-14 x 3 Serr
67	532 19 47-37	Bushing PM Front Axle
68	873 90 07-00	Nut Lock Flange 7/16-14 Gr. 5
69	532 19 91-62	Washer 1.5 x .505 x .118
70	585 33 88-01	Bracket Deck Susp. Front
75	580 68 37-01	Pinion
76	580 68 36-01	Screw Head Sock
122	532 44 49-62	Cap Gear

NOTE: All component dimensions given in U.S. inches
1 inch = 25.4 mm

TRACTOR - MODEL NO. TC 242T (96051019100), PRODUCT NO. 960 51 01-91
MOWER DECK 44

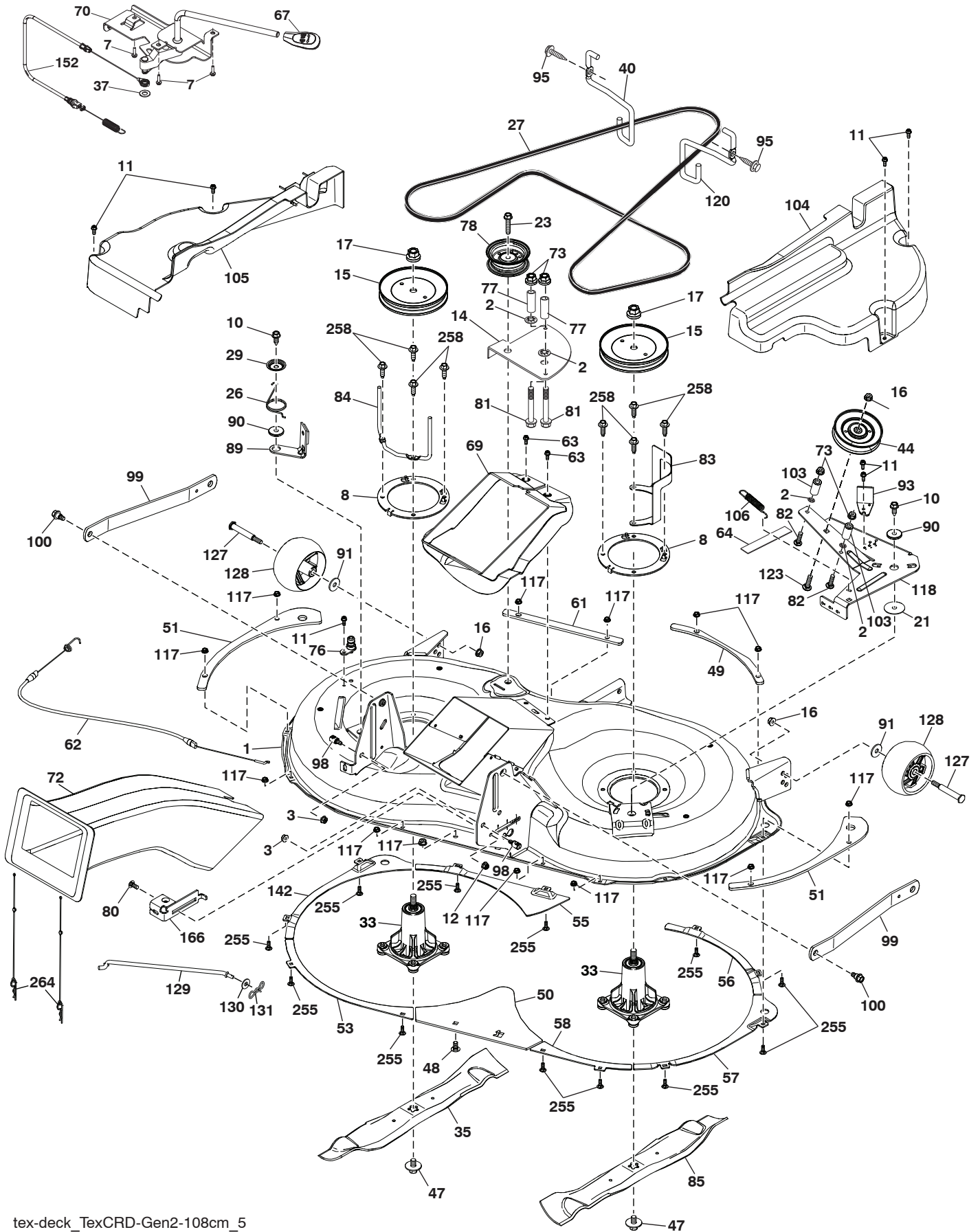

TRACTOR - MODEL NO. TC 242T (96051019100), PRODUCT NO. 960 51 01-91
MOWER DECK 44

KEY NO.	PART NO.	DESCRIPTION	KEY NO.	PART NO.	DESCRIPTION
1	597 95 92-01	Kit, SVC, Deck Weldment	73	582 47 86-02	Nut, Flg. Nylock 1/4-20 Gr.
2	532 42 30-62	Palnut 1/4	76	532 41 55-98	Washout Port
3	596 13 57-01	Nut, Lock, Prvl, Torq, 5/16-18 x .68	77	599 24 41-01	Spacer, Keeper
7	596 32 17-01	Screw #10 x .075, BOS, Thread	78	532 19 31-97	Pulley, Idler 48"Primary
8	595 96 02-02	Mandrel Reinforcement Plate	80	595 90 16-01	Bolt, Cup, 5/16-18 x 3/4, Clr, Znc
10	817 00 06-16	Screw, 3/8-16x1, Smgml, Tap/R, Blk	81	874 76 04-32	Bolt, Fin. Hex 1/4-20 x 2
11	532 13 77-29	Screw, Thd, Roll, 1/4-20 x 5/8	82	596 13 40-01	Bolt, Rdhd. Shrt. Nk. 1/4-20x 1-1/2
12	594 94 44-01	Nut, Hexagon, Flange, 5/16-18	83	595 53 33-02	Belt Keeper
14	599 24 40-02	Plate, Belt, Keeper	84	589 67 61-02	Belt Keeper
15	532 19 59-45	Pulley, Mandrel, 5.438 Pd, Zinc	85	594 02 48-02	Blade RH
16	873 90 06-00	Nut, Lock, Flg, 3/8-16 unc	89	599 24 42-02	Brake, Lever, Asm.
17	596 13 48-01	Nut, Hex, 9/16-18 x 1 .010	90	532 19 90-92	Spacer, Retainer
21	532 10 65-13	Washer, Wear, 16 Ga, Harden	91	596 13 49-01	Washer, Plain, 3/8 x 7/8
23	596 56 40-03	Bolt, Hex, 3/8-16 x 1.78, Clr, Zinc	93	532 19 94-70	Arm, Brake, Mower, 38" LH, Tex
26	532 19 84-10	Spring, Torsion, Brake	95	817 00 06-12	Screw Hexwsh 3/8-16 x 3/4
27	594 02 49-01	Belt	98	593 82 40-01	Stud, w/"D"Anti-Rotation
29	532 19 72-56	Spring, Torsion, Retainer	99	594 92 82-02	Arm, Deck, Suspension, MS 431
33	598 85 62-01	Kit, Mandrel, Non Grease, Rev (includes mandrel and bolts)	100	532 19 65-39	Bolt Shoulder
35	594 02 47-02	Blade LH	103	599 24 41-02	Spacer, Keeper
37	596 56 53-01	Washer 3/8x0.08in., ST, CLR, Zinc	104	594 02 59-01	Cover, Mandrel, Assy, RH
40	595 53 32-01	Keeper Belt Engine LH	105	594 02 58-01	Cover, Mandrel, Assy, LH
44	532 19 31-95	Pulley	106	599 69 85-01	Spring Extension
47	584 30 93-01	Screw, Sems, 7/16-20 x 1, Hex, Head	117	873 90 04-00	Nut, Hex, Flange, 1/4-20
48	596 13 60-01	Bolt, Cup, Head, 3/8-16 x 3/4	118	599 83 25-02	Arm, Tensioner
49	594 02 51-02	Plate, 108Cm, FR, RR, Reinforcment	120	597 64 68-01	Kepr Belt Engine RH
50	595 83 96-02	Plate, Rear, Containment, MS 431	123	596 13 61-01	Bolt, Cup, Head, 3/8-16 x 1-1/2"
51	594 02 50-02	Plate, 108cm, Side, Reinforcement	127	596 43 44-04	Bolt, Shoulder, 3/8-16 x 3-5/8"
53	597 25 25-02	Plate, 108cm, LH, RR, Containment	128	589 52 73-01	Wheel, Gauge, Wide (Rally)
55	597 25 27-02	Plate, 108cm, LH, FR, Containment	129	532 44 32-37	Rod Anti-Sway
56	597 25 28-02	Plate, 108cm, RH, FR, Containment	130	596 13 32-01	Washer 13/32 x 13/16 x 12 Ga.
57	597 25 24-02	Plate, 108cm, RH, Containment, 431	131	532 19 42-08	Pin Cotter 5/16 Bow Tie Lock
58	597 25 26-02	Plate, 108cm, RH, RR, Containment	142	597 25 23-02	Plate, 108cm, LH, Containmentx431
61	594 02 52-02	Plate, 108cm, FR, LH, reinfors, 431	152	594 03 30-01	Cable, Clutch Asm
62	594 03 29-01	Cable, Asmbrake	166	594 02 46-02	Bracket, Tension, Adjmnt x 431
63	585 51 78-01	Screw, Thd, Roll, 1/4-20 x 5/8	255	596 23 84-01	1/4-20 x 3/4 in., Gr 5, Bolt
64	532 42 54-17	Vibration, Pad	258	584 95 39-01	Bolt, Hex, Washr, Hed, .313-18x1, 19
67	532 40 30-12	Handle, Clutch, Cable	264	589 39 29-02	Retainer Asm., Chute, CRD 2.5, Tex
69	597 25 22-01	Lower, Chute, Sealing Collar	- -	597 95 93-01	Replacement Mower Complete
70	532 19 99-72	Clutch Asm., Manual			
72	581 45 41-04	Chute, Slotted, Holes, Tex, CRD, II			

NOTE: All component dimensions given in U.S. inches
1 inch = 25.4 mm

TRACTOR - MODEL NO. TC 242T (96051019100), PRODUCT NO. 960 51 01-91
MOWER LIFT 45

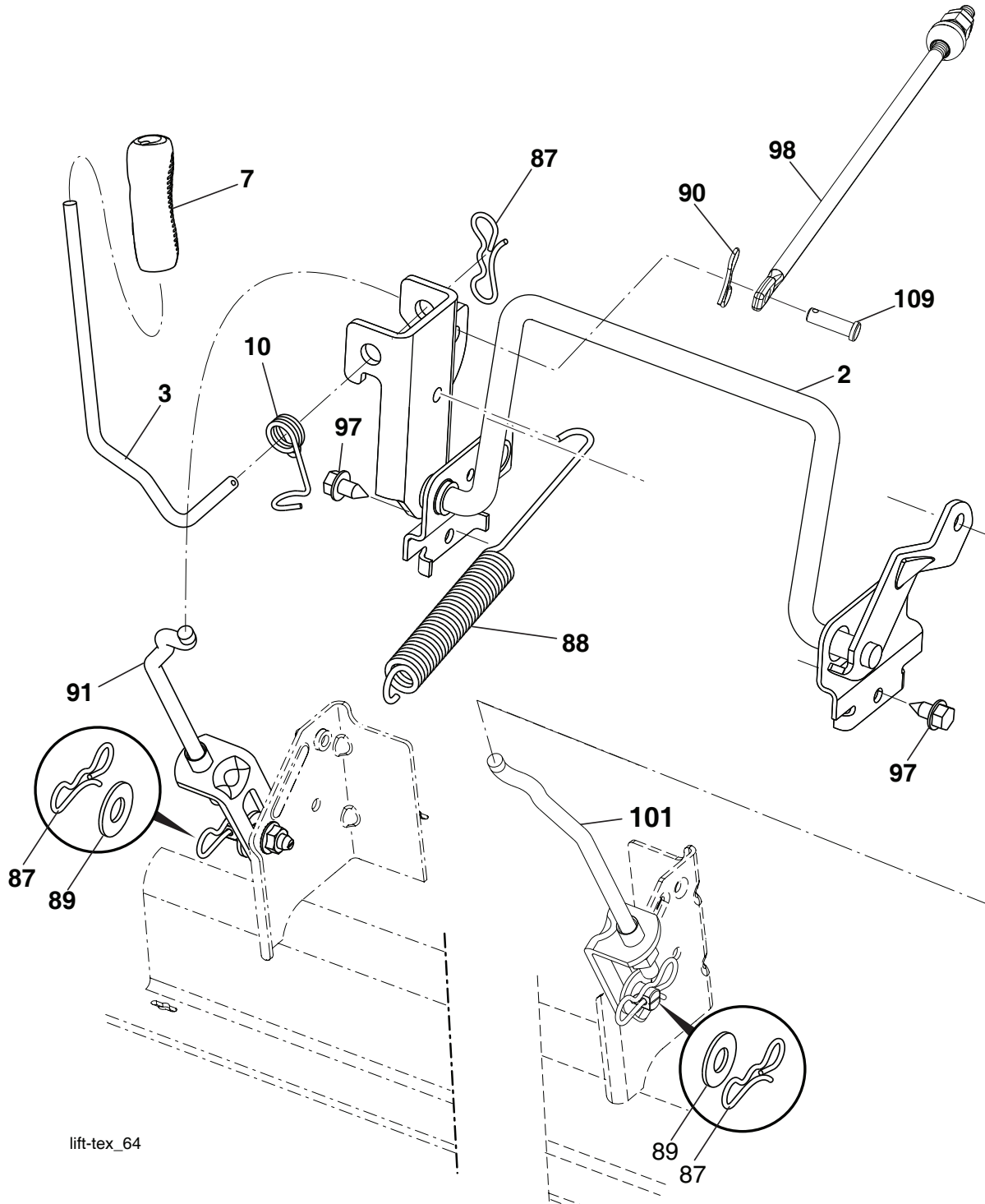

lift-tex_64

KEY NO.	PART NO.	DESCRIPTION
2	532 43 69-96	Deck Lift Weldment
3	594 01 80-01	Lever, Lift, Handle
7	580 96 23-01	Grip, Lever
10	532 19 63-14	Spring Torsion
87	532 19 42-09	Pin Cotter 7/16 Bow Tie Lock
88	532 44 54-96	Spring Lift Assist
89	819 19 19-12	Washer Clear Zinc
90	532 19 42-08	Pin Cotter 5/16 Bow Tie Lock

KEY NO.	PART NO.	DESCRIPTION
91	589 46 48-06	Link, Assy, Lift, Rear
97	596 56 40-01	Hex, Bolt w/Collar, 3/8-16 x 0.53
98	595 96 07-02	Link, Asm
101	589 46 48-07	Link, Asm. Lift, Rear
109	539 10 92-32	Pin, Clevis 3/8 x 1 1/4

NOTE: All component dimensions given in U.S. inches
 1 inch = 25.4 mm

**TRACTOR - MODEL NO. TC 242T (96051019100), PRODUCT NO. 960 51 01-91
SEAT ASSEMBLY 42**

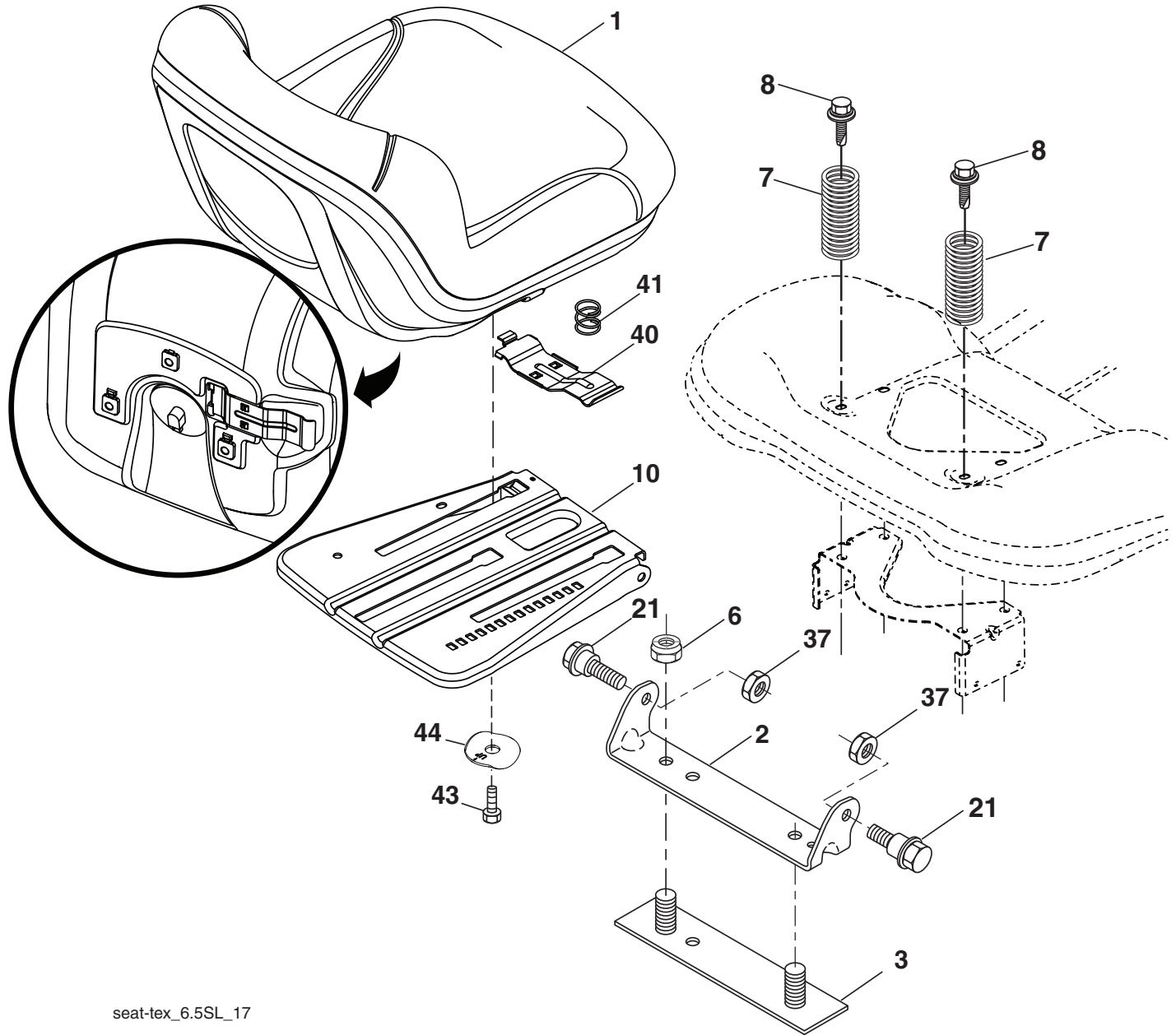

seat-tex_6.5SL_17

KEY NO.	PART NO.	DESCRIPTION
1	532 43 98-22	Seat
2	532 18 01-66	Bracket Pivot Fender
3	532 14 06-75	Strap, Asm Fender
6	873 80 06-00	Nut, Lock w/Ins. 3/8-16 unc
7	589 48 35-01	Spring, Seat Cprsn
8	532 17 18-77	Bolt 5/16-18 unc x 3/4 w/Sems
10	596 65 74-02	Seat Plate
21	587 90 78-01	Bolt, Shoulder 5/16-18 x 5/8

KEY NO.	PART NO.	DESCRIPTION
37	596 58 37-02	Nut w/Nonmetal, Ins, Blk, Zinc
40	595 08 81-02	Handle Slide Seat
41	532 19 82-00	Spring Latch Seat
43	874 76 06-12	Bolt Fin Hex 3/8-16 unc x 3/4
44	501 05 18-01	Washer Winged

NOTE: All component dimensions given in U.S. inches
1 inch = 25.4 mm

TRACTOR - MODEL NO. TC 242T (96051019100), PRODUCT NO. 960 51 01-91
BAGGER 46

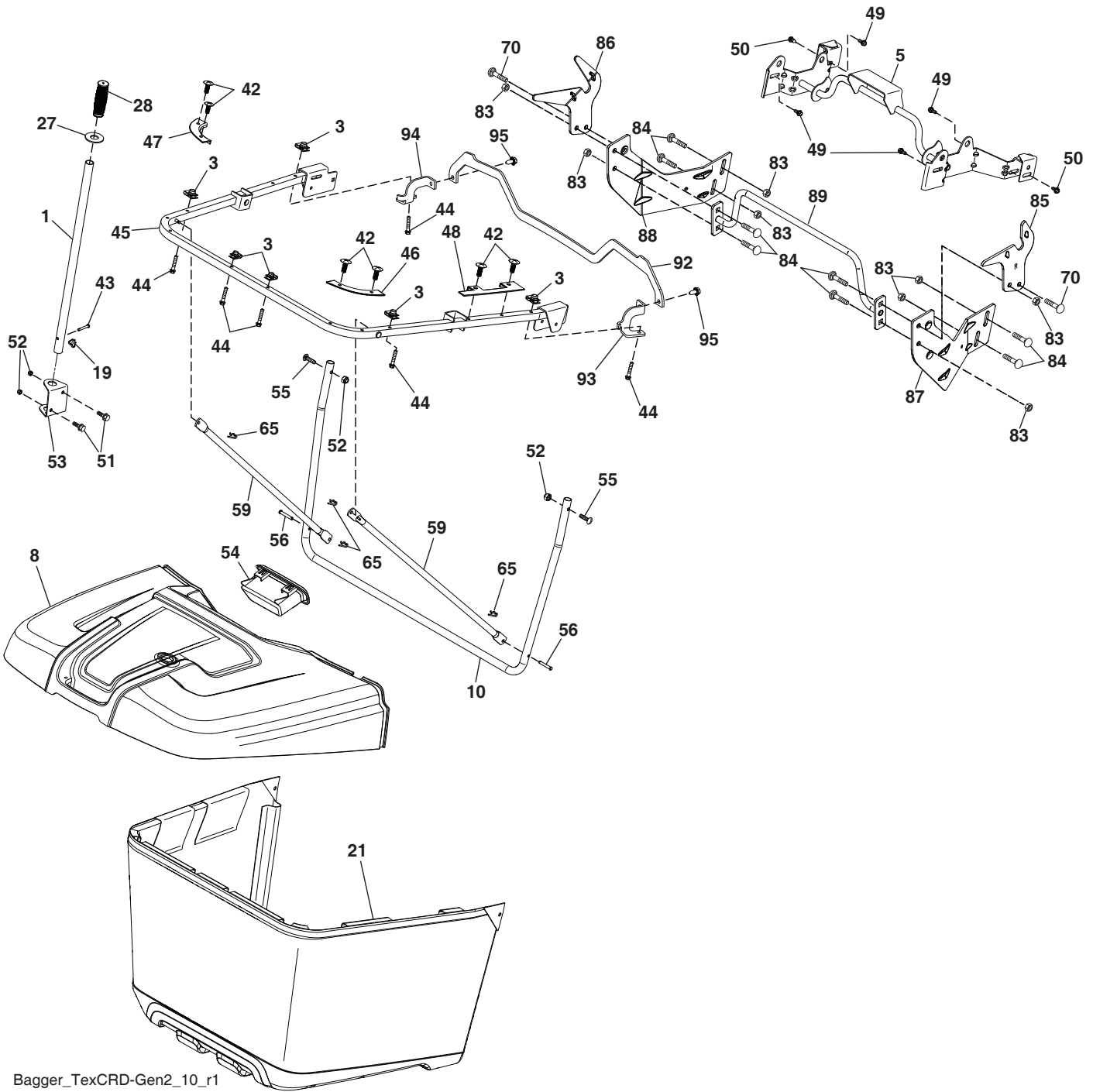

Bagger_TexCRD-Gen2_10_r1

**TRACTOR - MODEL NO. TC 242T (96051019100), PRODUCT NO. 960 51 01-91
BAGGER 46**

KEY NO.	PART NO.	DESCRIPTION
1	532 42 86-10	Tube Handle Bagger
3	532 17 48-14	Nut Push
5	532 44 37-62	Frame Asm Top Bagger
8	587 58 86-01	Cover Bagger
10	532 44 37-55	Frame Front
19	532 19 42-08	Cotter Pin 5/16 Bow Tie
21	581 33 71-03	Bag Asm
27	532 44 55-29	Grommet Rubber
28	532 16 57-87	Grip Handle Black
42	532 44 04-28	Christmas Tree Clip
43	532 12 68-75	Clevis Pin
44	532 19 96-87	Bolt 1/4-20 1.50
45	532 44 37-54	Upper U Frame Weldment
46	532 44 55-41	Bagger Corner Close-Out RH
47	532 44 40-79	Bagger Corner Close-Out LH
48	532 44 40-80	Top Bagger Side Close-Out
49	532 17 18-73	Bolt Shoulder 5/16-18 TT
50	532 17 18-77	Bolt 5/16-18 unc x 3/4 w/SEMS
51	872 11 05-06	Bolt RDHDSQNK 5/16-18 unc x 3/4
52	596 58 37-02	Nut W/Nonmetal, Ins, Blk, Zinc
53	532 44 41-95	Bracket Dump Handle
54	532 44 72-18	Bagger TOP Front Handle
55	596 03 08-01	Bolt, 5/16-18 x 1/2 Gr. 5 CLR ZN
56	532 42 03-06	Pin Clevis 1.83 OD x 1.26 long
59	532 44 47-63	Bagger Spread Tube
65	532 00 44-97	Clip Retainer
70	817 00 06-12	Bolt 3/8-16 x 3/4
83	873 80 06-00	Nut Lock Hex w/Ins 3/8-16
84	596 72 82-01	Bolt, Carri, 3/8-16 x 1", Gr. 5
85	581 31 44-02	Bracket RH Pivot
86	581 31 43-02	Bracket LH Pivot
87	581 31 48-02	Bracket RH
88	581 31 47-02	Bracket LH
89	581 31 51-04	Tube Asm.
92	586 05 23-02	Bracket Top Support
93	586 05 24-02	Bracket Support RH
94	586 05 25-02	Bracket Support LH
95	817 00 05-12	Screw 5/16-18 x 3/4
--	501 70 56-01	Bagger Dump Kit (Includes Key#'s 85, 86, 87, 88, & 89)
--	586 74 49-01	Bagger Complete Kit (Includes Key#'s 1, 5, 10, 19, 21, 27, 28, 42, 43, 46, 47, 48, 49, 50, 52, 54, 56, 59, 65)

NOTE: All component dimensions given in U.S. inches
1 inch = 25.4 mm

