

Repair Parts Manual
Manual De Repuestos
TS 146X / 96043030100

Please read the operator's manual carefully and make sure you understand the instructions before using the machine.

Por favor lea cuidadosamente y comprenda estas instrucciones antes de usar esta maquina.



English/Spanish

114 17 02-49 Rev. 3



HOW TO USE THIS MANUAL

This manual is designed to provide the customer with a means to identify the parts on his/her tractor when ordering repair parts. The illustrations may or may not represent the actual assemblies; therefore, it is not recommended to use this manual as a guide to assemble or disassemble the tractor. Some hardware and parts are drawn larger in order to more readily identify them.

Each tractor has its own model number. The model number for your tractor can be found on the fender under the seat.

Support / Help

If you require assistance or have questions concerning the application, operation, maintenance or parts for your product:

- Visit our website: www.husqvarna.com
- Call Us Toll Free: 1-800-487-5951

When ordering parts, always give the following information:

- Product - "TRACTOR"
- MODEL NUMBER - "TS 146X" (96043030100)"
- Part Number
- Part Description

TABLE OF CONTENTS

SCHEMATIC	3
ELECTRICAL	4-5
CHASSIS	6-7
DRIVE	8-9
ENGINE	10-11
STEERING	12-13
MOWER DECK	14-15
MOWER LIFT	16
SEAT	17
DECALS	18

COMO UTILIZAR ESTE MANUAL

Este manual está diseñado para brindarle al comprador un medio para identificar las piezas del tractor para cuando necesite hacer el pedido de un repuesto. Las ilustraciones pueden o no representar los ensambles reales; por lo tanto, no se recomienda utilizar este manual como una guía para ensamblar o desarmar el tractor. Algunos accesorios y piezas están dibujados en tamaños más grandes para identificarlos con mayor facilidad.

Cada tractor tiene su propio número de modelo. El número de modelo del tractor se encuentra en el guardabarros debajo del asiento.

Soporte / Ayuda

Si necesita asistencia o tiene alguna pregunta acerca de la aplicación, operación, mantenimiento o piezas de su producto:

- Visite nuestro sitio web: www.husqvarna.com
- Llámenos de manera gratuita al: 1-800-487-5951

Cuando haga el pedido de una pieza, siempre brinde la siguiente información:

- Producto: "TRACTOR"
- NÚMERO DE MODELO: "TS 146X" (96043030100)"
- Número de pieza
- Descripción de la pieza

ÍNDICE

DIAGRAMA	19
DIAGRAMA ELÉCTRICO	20-21
CHASIS	22-23
TRANSMISIÓN	24-25
MOTOR	26-27
DIRECCIÓN	28-29
PLATAFORMA DE LA CORTADORA DE CÉSPED	30-31
ELEVACIÓN DE LA CORTADORA DE CÉSPED	32
ASIENTO	33
CALCOMANÍAS	34

TRACTOR - MODEL NO. TS 146X (96043030100), PRODUCT NO. 960 43 03-01 SCHEMATIC

SCH11

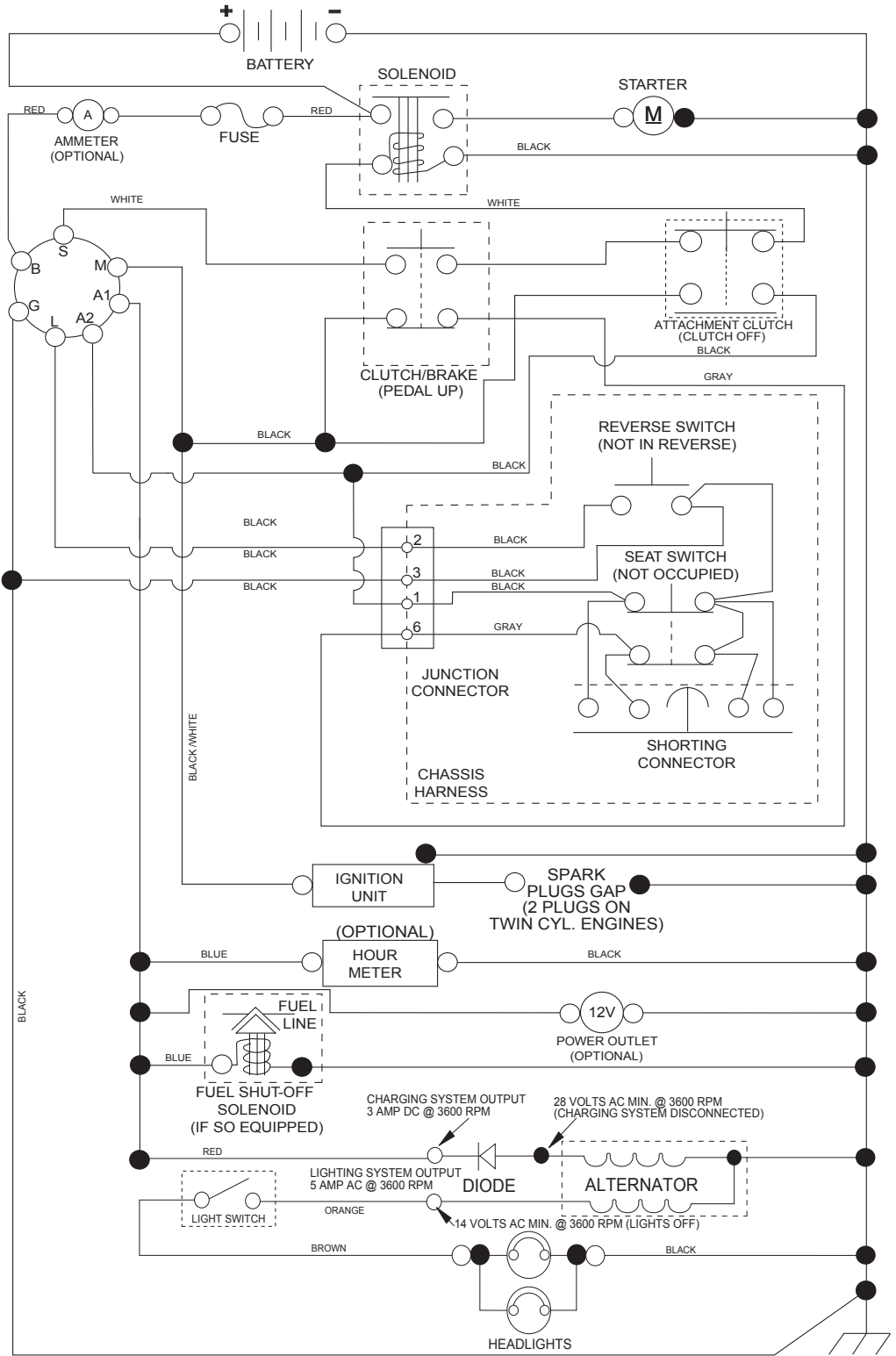

NOTE
YOUR TRACTOR IS EQUIPPED WITH A SPECIAL ALTERNATOR SYSTEM. THE LIGHTS ARE NOT CONNECTED TO THE BATTERY, BUT HAVE THEIR OWN ELECTRICAL SOURCE. BECAUSE OF THIS, THE BRIGHTNESS OF THE LIGHTS WILL CHANGE WITH ENGINE SPEED. AT IDLE THE LIGHTS WILL DIM. AS THE ENGINE IS SPEEDED UP, THE LIGHTS WILL BECOME THEIR BRIGHTEST.

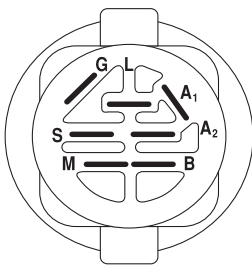

IGNITION SWITCH

POSITION	CIRCUIT	"MAKE"
OFF	M+G+A1	
RUN/OVERRIDE	B+A1	
RUN	B+A1	L+A2
START	B + S + A1	

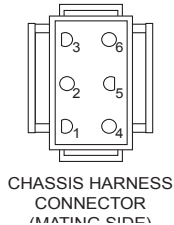

CHASSIS HARNESS CONNECTOR (MATING SIDE)

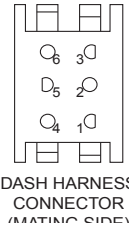

DASH HARNESS CONNECTOR (MATING SIDE)

WIRING INSULATED CLIPS
NOTE: IF WIRING INSULATED CLIPS WERE REMOVED FOR SERVICING OF UNIT, THEY SHOULD BE RE-INSTALLED TO PROPERLY SECURE YOUR WIRING.

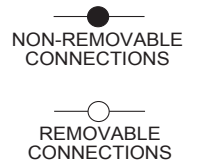

**TRACTOR - MODEL NO. TS 146X (96043030100), PRODUCT NO. 960 43 03-01
ELECTRICAL**

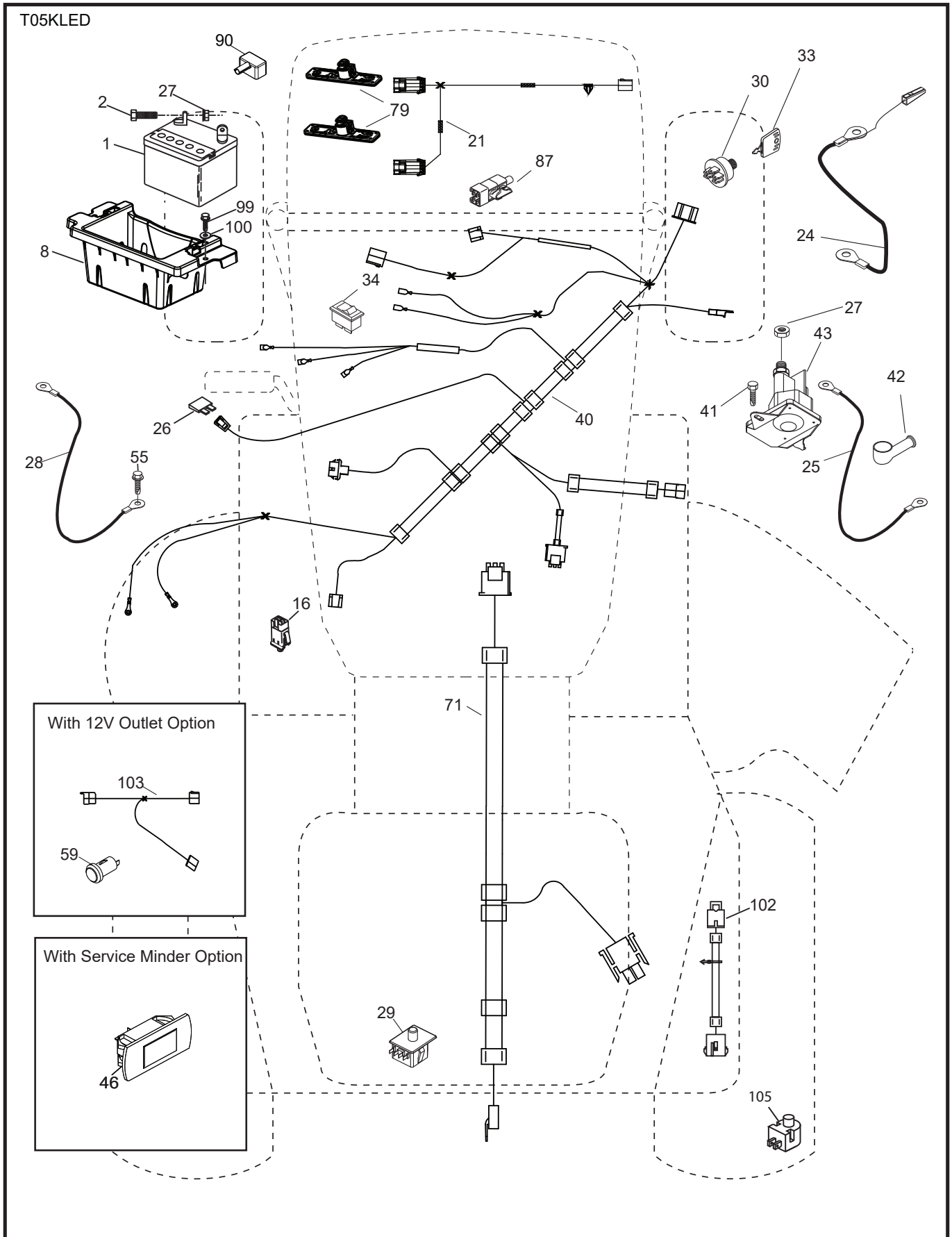

**TRACTOR - MODEL NO. TS 146X (96043030100), PRODUCT NO. 960 43 03-01
ELECTRICAL**

KEY NO.	PART NO.	DESCRIPTION
1	532 16 34-65	Battery
2	874 76 04-12	Bolt Hex Head 1/4-20 x 3/4
8	587 20 51-01	Battery, Tray
16	532 17 61-38	Switch Interlock Push-In
21	585 43 64-02	Harness, LED Lights
24	585 55 56-01	Cable, FR Batt
25	585 55 55-01	Cable Starter
26	532 17 51-58	Fuse
27	596 13 36-01	Locknut, Keps, 1/4-20
28	532 41 65-88	Cable, Ground
29	532 19 27-49	Switch, Seat
30	532 19 33-50	Switch, Ign
33	532 41 19-33	Key/Chain
34	532 11 07-12	Switch Light/Reset
40	501 13 30-01	Harness Ign. Dash
41	817 72 04-08	Screw, Thd., Cut 1/4-20 x 1/2
42	532 13 15-63	Cover, Terminal
43	582 04 28-02	Solenoid
46	594 91 91-01	Hourmeter, SRVminder
55	817 06 05-12	Screw Thdrol 5/16-18 x 3/4 TYTT
71	532 19 42-76	Harness Ign. Chassis
79	597 52 30-01	Light, LED Bar
87	532 19 78-02	Switch Interlock
90	532 43 53-95	Cover Terminal
99	817 67 04-12	Screw Hexwsh
100	596 13 53-01	Washer, Plain, 9/32 X 7/8, Clr, Zn
102	532 40 44-54	Harness Pigtail
105	532 40 75-68	Switch Reverse

NOTE: All component dimensions given in U.S. inches
1 inch = 25.4 mm

**TRACTOR - MODEL NO. TS 146X (96043030100), PRODUCT NO. 960 43 03-01
CHASSIS**

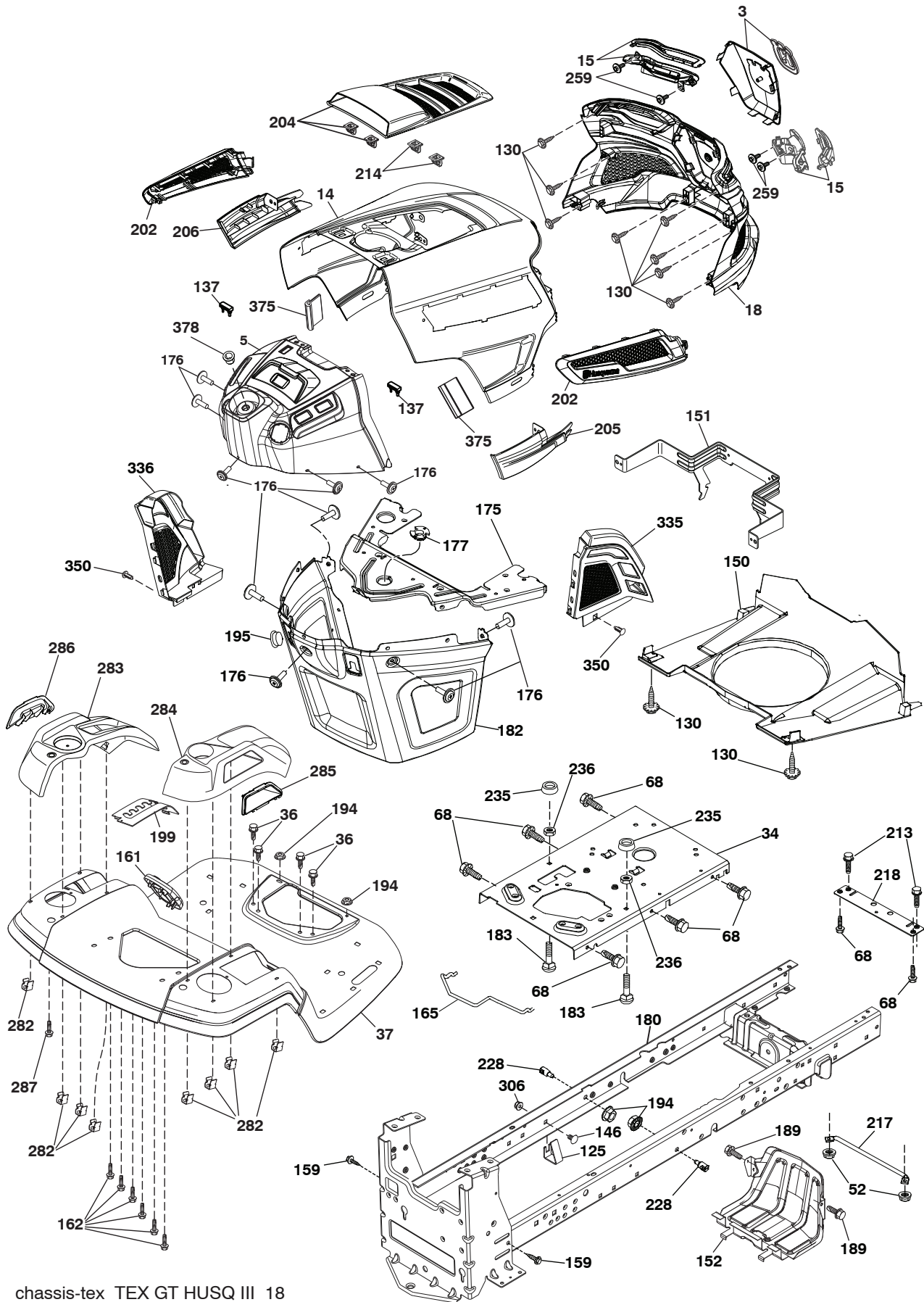

chassis-tex_TEX GT HUSQ III_18

TRACTOR - MODEL NO. TS 146X (96043030100), PRODUCT NO. 960 43 03-01 CHASSIS

KEY NO.	PART NO.	DESCRIPTION	KEY NO.	PART NO.	DESCRIPTION
3	597 68 82-01	Kit, Grille Applique, (includes applique cover and emblem badge)	195	532 40 41-37	Plug Hole Dash Lower
5	590 74 88-23	Dash	199	532 41 34-85	Plate Deck Lift
14	532 44 11-77	Hood	202	597 86 77-01	Kit, Side Vents, LH/RH (includes LH/RH side vents)
15	597 86 79-01	Kit, SVC, Hus GT3, LED Headlights (includes LH/RH lens and LH/RH housing)	204	597 40 80-01	Kit, Top Vent (includes top vent and clip retainers)
18	597 40 71-02	Grille	205	532 43 97-30	Skirt Hood Side RH
34	580 91 08-01	Plate Engine	206	532 43 97-29	Skirt Hood Side LH
36	817 06 05-12	Screw 5/16-18 x 3/4	213	596 03 05-01	Screw, Hex, Hd, 5/16-18 unc x 3/4
37	532 44 11-78	Fender	214	532 19 91-45	Clip Retainer Tinner
52	596 04 05-01	Nut, Lock, Hex, Prvl, 5/16-18	217	532 40 91-67	Rod Pivot
68	596 03 07-01	Screw, Hexagon, 5/16-18 x 1/2	218	532 19 63-95	X-Piece Hood Stop
125	581 68 48-01	Clip Fuel Line	228	532 19 51-61	Stud Fastner
130	596 32 17-01	Screw, #10 x 0.750, Bos, Thread	235	596 56 42-01	Spacer, Fender, Clr, Zn
137	532 40 75-90	Bumper Dash	236	873 93 05-00	Nut Lock 5/16-18 unc
146	581 85 79-01	Bolt RDH SHT SQNK 3/8-16 x 5/8	259	596 43 40-01	Screw #10.10 x 0.500, Bos Thread
150	532 43 97-74	Air Duct	282	532 41 41-10	Clip, Retainer, Console
151	532 43 66-70	Bracket Pivot	283	532 43 98-61	Console, Deck Lift, Fuel
152	532 43 98-70	Shield Browning	284	532 43 98-23	Console, Pedal Shift
159	817 00 06-12	Screw Hexwsh Thrd 3/8-16 x 3/4	285	532 41 63-15	Insert, Shift, Console
161	532 43 97-81	Fuel Window	286	532 41 63-17	Insert, Deck Lift, Console
162	596 13 41-01	Screw, Hex, Tap, 1/4-15 x 1/2	287	817 60 04-06	Screw 1/4-20 x 3/8
165	532 19 68-26	Support, Rear Tank	306	873 90 06-00	Nut Lock Flange 3/8-16 unc
175	590 60 77-02	Crossmember	335	532 44 82-04	Cover RH
176	532 40 07-76	Screw 10-24 x 5/8	336	532 44 53-09	Cover LH
177	532 19 52-28	Bushing Steering	350	532 44 51-43	Clip X-mas Tree
180	532 19 54-57	Chassis	375	586 90 82-01	Dash Clip-On Bumper
182	532 40 68-59	Dash Lower	378	590 84 98-01	Bushing, Flange, Plastic
183	595 30 57-01	Screw, Hexagon, 5/16-18 x 1-1/4			
189	817 00 05-12	Screw 5/16-18 x 3/4			
194	596 13 57-01	Nut, Lock, Prvl, Torq, 5/16-18 x .68			

NOTE: All component dimensions given in U.S. inches
1 inch = 25.4 mm

**TRACTOR - MODEL NO. TS 146X (96043030100), PRODUCT NO. 960 43 03-01
DRIVE**

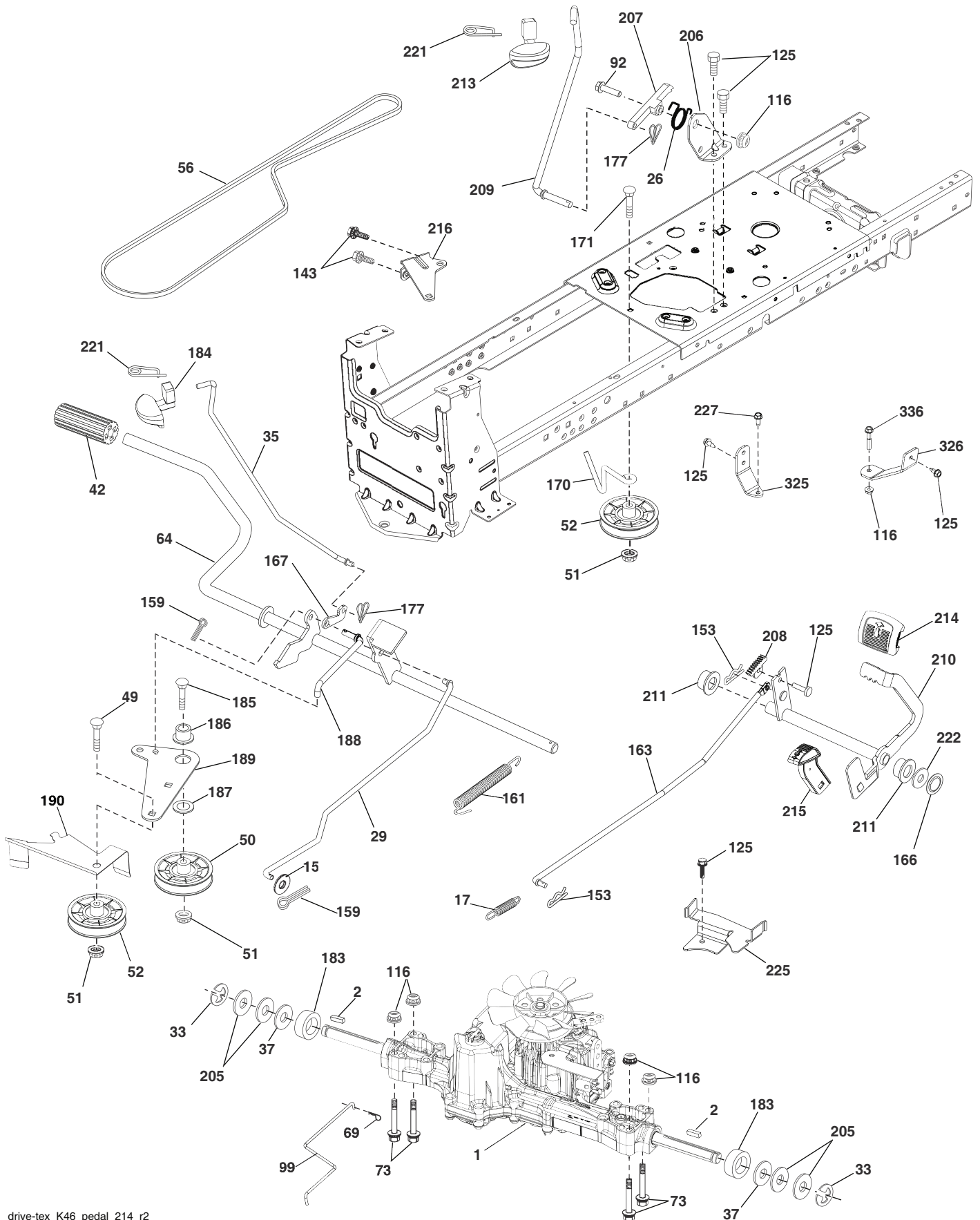

drive-tex_K46_pedal_214_r2

TRACTOR - MODEL NO. TS 146X (96043030100), PRODUCT NO. 960 43 03-01 DRIVE

KEY NO.	PART NO.	DESCRIPTION	KEY NO.	PART NO.	DESCRIPTION
1	---	Transaxle, Tufftorq K46BT (426120) (Order parts from transaxle manufacturer.)	177	587 22 53-01	Pin, Cotter, Locking, Bowtie, 1 In.
2	532 12 35-83	Key Square	183	532 13 70-57	Spacer Axle
15	819 13 13-16	Washer 13/32 x 13/16 x 16 Ga.	184	587 65 37-01	Handle Parking Brake
17	532 41 36-78	Spring, Brake	185	872 11 06-22	Bolt
26	532 19 96-79	Spring Return Cruise	186	532 19 43-21	Spacer Retainer
29	532 40 38-06	Rod, Brake	187	596 13 55-01	Washer, 13/32 x 2, Clear, Zinc
33	812 00 00-01	Ring E	188	582 21 70-01	Link Clutch Ground Drive, Long
35	590 60 59-02	Rod, Brake, Park	189	532 19 43-17	Bellcrank Ground Drive
37	532 18 89-67	Washer .793 x 1.637 x 060	190	532 19 43-18	Keeper Bellcrank Ground Drive
42	532 00 88-83	Cover, Foot Pedal	205	532 12 17-48	Washer 25/32 x 1-5/8 x 16 Ga.
49	596 13 62-01	Bolt, Cup, Head, 3/8-16 x 3/4	206	532 44 85-96	Bracket Mount Latch Cruise
50	532 19 43-27	Pulley Idler Flat	207	587 03 14-02	Latch Control Cruise
51	873 90 06-00	Lock Nut 3/8-16	208	596 56 41-01	Gear Sector Control Cruise
52	532 19 43-26	Idler V-Groove	209	590 52 78-02	Rod Control Cruise
56	592 85 52-01	V-Belt, Drive	210	532 40 09-80	Rocker Asm. Pedal Control
64	532 19 78-65	Shaft Asm. Pedal Brake Control	211	532 12 01-83	Bearing Nylon
69	532 42 33-03	Hairpin Soft Zink .059 x 1.125	213	532 40 31-19	Knob Control Cruise
73	596 13 65-01	Bolt, Hex, Head, 5/16-18 x 1-1/2	214	532 42 12-63	Pedal Forward
92	595 30 57-01	Screw, Hexagon, 5/16-18 x 1-1/4	215	586 60 65-02	Pedal Reverse
99	582 40 45-01	Rod Spring Bypass	216	532 19 61-31	Bracket Pulley Idler
116	596 13 57-01	Nut, Lock, Prvl, Torq, 5/16-18 x .68	221	532 40 31-87	Retainer Spring Clip Handle
125	817 00 05-12	Screw 5/16-18 x 3/4	222	879 21 20-10	Washer 21/32 x 1-1/4 10 Ga.
143	596 03 07-01	Screw, Hexagon, 5/16-18 x 1/2	225	532 40 33-19	Keeper Belt Transaxle
153	532 00 44-97	Retainer Spring 1"	227	596 13 59-01	Bolt, Hex, 5/16-18 x 3/4, Clr, Znc
159	596 02 95-01	Pin, Cotter, 1/8 Dia x 3/4	325	585 66 85-02	Torque Strap K46 LT RH
161	532 10 57-09	Spring, Return, Clutch	326	585 67 08-02	Bracket TRQ STP 46 20" Tire RH
163	593 86 10-01	Rod, Control, K46/K57R	336	587 25 96-02	Bolt 5/16 - 18 x 1-3/4 Flanged
166	532 42 91-64	Nut Push			
167	532 40 52-57	Latch Brake Parking			
170	532 19 43-22	Keeper V-Idler			
171	596 13 63-01	Bolt, Cup, Head, 3/8-16 x 2			

NOTE: All component dimensions given in U.S. inches
1 inch = 25.4 mm

**TRACTOR - MODEL NO. TS 146X (96043030100), PRODUCT NO. 960 43 03-01
ENGINE**

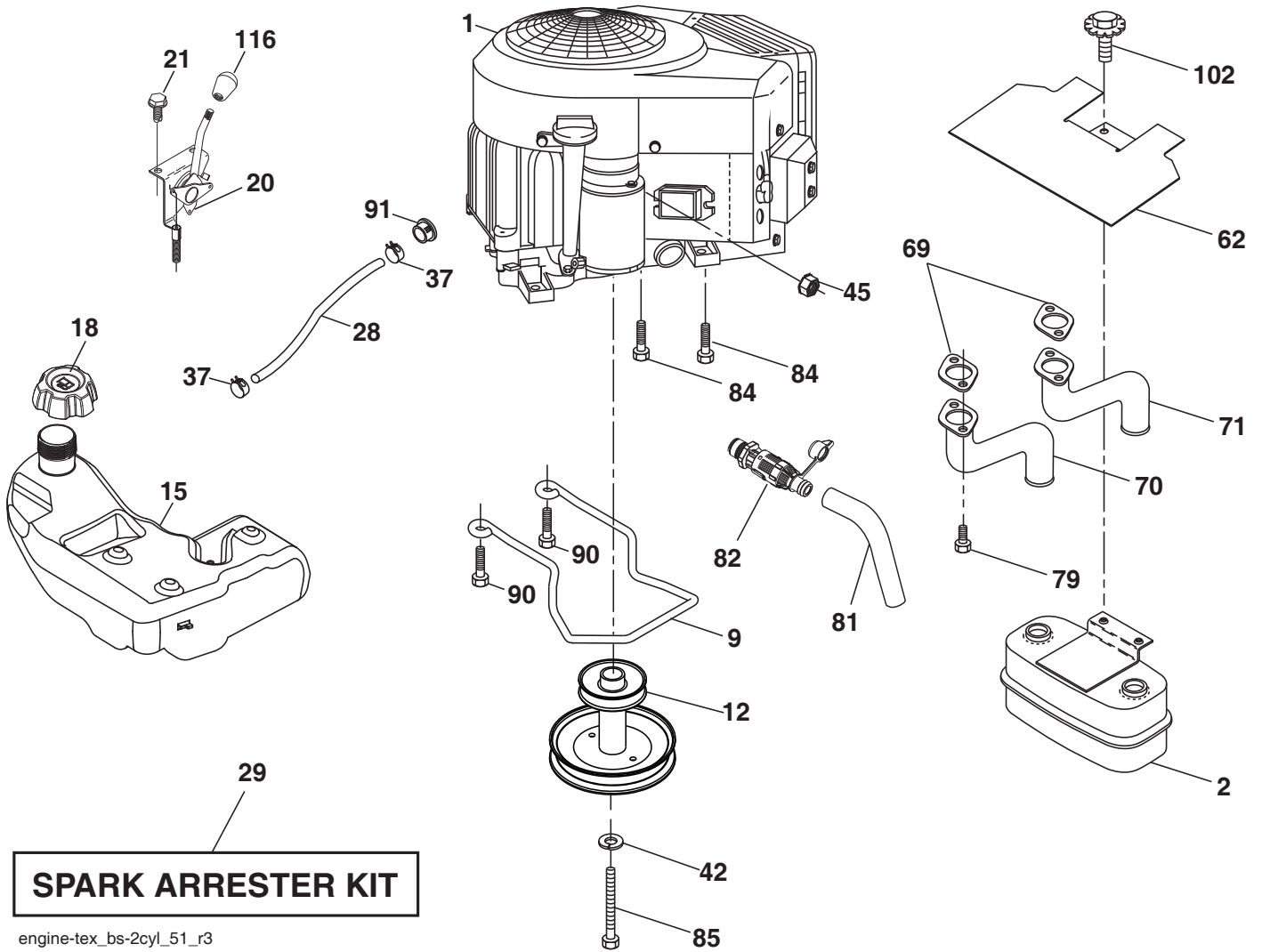

TRACTOR - MODEL NO. TS 146X (96043030100), PRODUCT NO. 960 43 03-01 ENGINE

KEY NO.	PART NO.	DESCRIPTION
1	- - - - -	Engine B&S Model No.40N677-0027-G1 (501709001)(Order parts from engine manufacturer.)
2	589 81 87-01	Muffler
9	501 83 26-02	Keeper Belt Engine
12	586 72 89-01	Pulley Engine
15	532 43 80-28	Tank Fuel
18	585 12 48-01	Cap Fuel
20	587 24 27-01	Throttle, Pro, Rstart, 38
21	596 32 17-01	Screw, #10 x 0.750, Bos, Thread
28	532 40 11-35	Fuel Line
29	532 13 71-80	Spark Arrester Kit
37	532 12 34-87	Clamp Hose
42	596 23 89-01	Washer, 7/16 In, Clr, Zn
45	596 13 36-01	Locknut, Keps, 1/4-20
62	532 43 40-17	Shield Heat Muffler
69	532 16 53-91	Gasket
70	581 88 11-01	Exhaust Tube LH
71	581 88 10-01	Exhaust Tube RH
79	596 13 42-02	Screw, Socket, 5/16-18 x 1, Clr, Zn
81	532 14 84-56	Tube Drain Oil Easy
82	532 42 82-87	Valve Drain Oil
84	817 06 06-20	Screw 3/8-16 x 1-1/4
85	501 60 65-01	Bolt 7/16-20 x 4 x Gr. 5-1.5
90	817 00 06-16	Screw 3/8-16 x 1
91	532 18 74-95	Bushing 1.375 OD
102	817 00 05-12	Screw 5/16-18 x 3/4
116	539 13 26-24	Knob

NOTE: All component dimensions given in U.S. inches
1 inch = 25.4 mm

For engine service and replacement parts, call the toll free number for your engine manufacturer listed below:

Briggs & Stratton 1-800-233-3723

Engine Power Rating Information

The gross power rating for individual gas engine models is labeled in accordance with SAE (Society of Automotive Engineers) code J1940 (Small Engine Power & Torque Rating Procedure), and rating performance has been obtained and corrected in accordance with SAE J1995 (Revision 2002-05). Torque values are derived at 3060 RPM; horsepower values are derived at 3600 RPM. Actual gross engine power will be lower and is affected by, among other things, ambient operating conditions and engine-to-engine variability. Given both the wide array of products on which engines are placed and the variety of environmental issues applicable to operating the equipment, the gas engine will not develop the rated gross power when used in a given piece of power equipment (actual "on-site" or net power). This difference is due to a variety of factors including, but not limited to, accessories (air cleaner, exhaust, charging, cooling, carburetor, fuel pump, etc.), application limitations, ambient operating conditions (temperature, humidity, altitude), and engine-to-engine variability. Due to manufacturing and capacity limitations, Briggs & Stratton may substitute an engine of higher rated power for this Series engine.

TRACTOR - MODEL NO. TS 146X (96043030100), PRODUCT NO. 960 43 03-01
STEERING ASSEMBLY

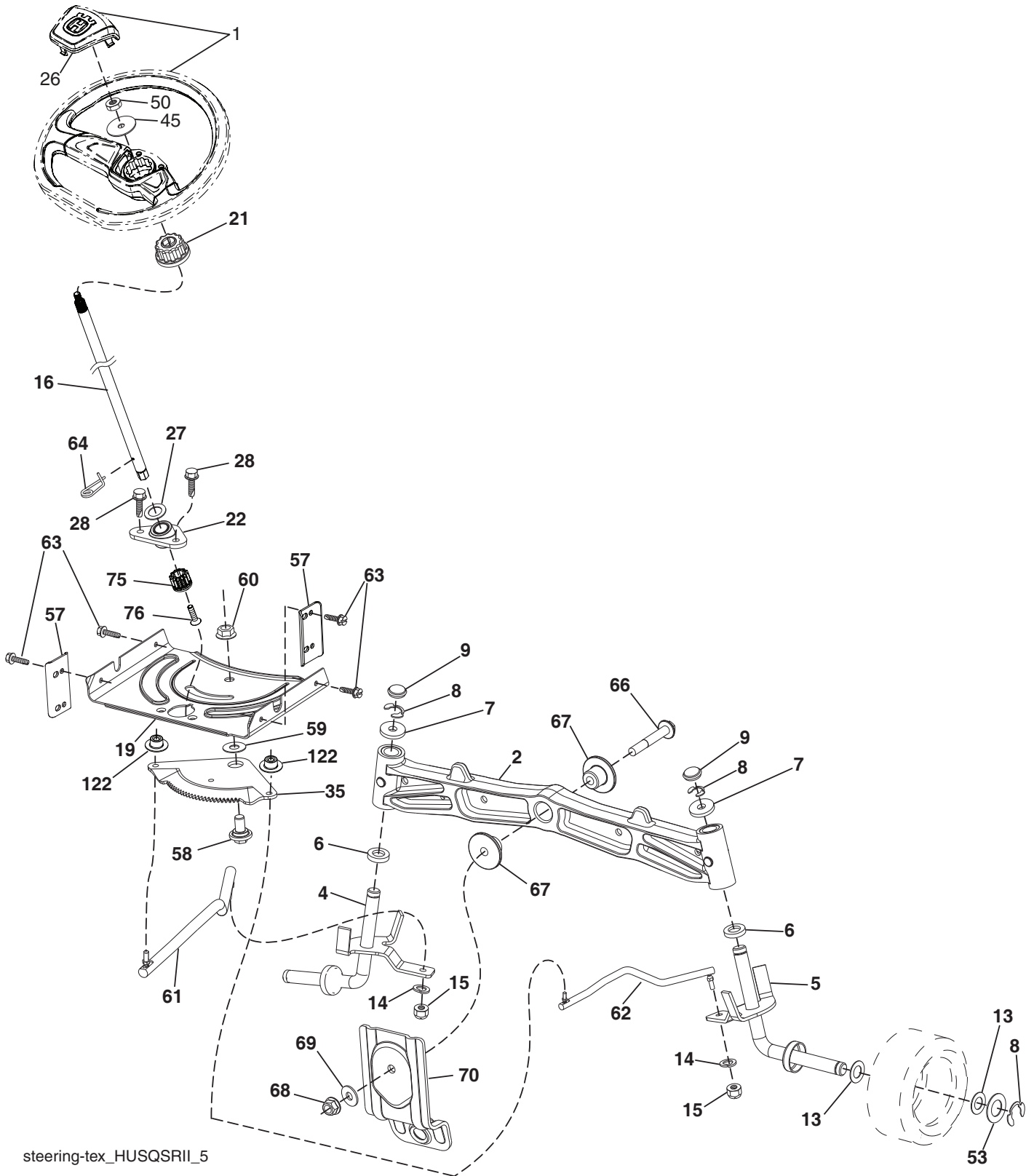

steering-tex_HUSQSR11_5

**TRACTOR - MODEL NO. TS 146X (96043030100), PRODUCT NO. 960 43 03-01
STEERING ASSEMBLY**

KEY NO.	PART NO.	DESCRIPTION
1	597 86 61-01	Wheel, Steering, Kit (includes steering wheel and cap)
2	532 19 59-68	Axle Cast Iron
4	532 40 30-87	Spindle Asm., LH
5	532 40 30-88	Spindle Asm., RH
6	532 00 62-66	Washer, Thrust .75 x 1.230
7	532 12 17-48	Washer 25/32 x 1-5/8 x 16 Ga.
8	812 00 00-29	Ring, Klip #T5304-75
9	532 12 12-32	Cap, Spindle
13	532 12 17-49	Washer 25/32 x 1-1/4 x 16 Ga.
14	596 23 87-01	Washer, Spring, Lock, 381ID x .680
15	873 54 06-00	Nut, Crown Lock 3/8-24 unf
16	587 01 60-02	Steering Shaft
19	532 19 47-29	Plate Steering
21	586 84 02-01	Adapter Wheel Steering
22	585 02 98-02	Bearing
26	594 94 91-01	Cap, Wheel, Steering
27	596 93 34-01	Washer, Plain
28	817 00 06-12	Screw 3/8-16 x 3/4
35	532 19 47-32	Gear, Sector Plate
45	587 01 64-01	Washer 3/8 ID 2-3/8 OD 12 Ga. PLTD
50	873 90 06-00	Nut Lock Flg 3/8-16 unc
53	532 18 89-67	Washer Hardened .793 x 1.637 x .060
57	532 40 74-65	Bracket Upstop
58	532 19 47-47	Bolt Shoulder Sector Pivot CFM
59	532 19 47-48	Washer Thrust Sector Steering
60	873 97 10-00	Nut Flange Lock 5/8-11
61	597 07 02-02	Draglink, LH, Adj, Std, Clrzn
62	597 07 03-02	Draglink, RH, Adj, Std, Clrzn
63	817 00 05-12	Screw 5/16-18 x 3/4
64	532 19 98-49	Retainer Clip Spring Steering
66	871 02 07-48	Bolt Hex Fghd 7/16-14 x 3 Serr
67	532 19 47-37	Bushing PM Front Axle
68	873 90 07-00	Nut Lock Flange 7/16-14 Gr. 5
69	532 19 91-62	Washer 1.5 x .505 x .118
70	585 33 88-01	Bracket Deck Susp. Front
75	580 68 37-01	Pinion
76	580 68 36-01	Screw Head Sock
122	532 44 49-62	Cap Gear

NOTE: All component dimensions given in U.S. inches
1 inch = 25.4 mm

TRACTOR - MODEL NO. TS 146X (96043030100), PRODUCT NO. 960 43 03-01
MOWER DECK

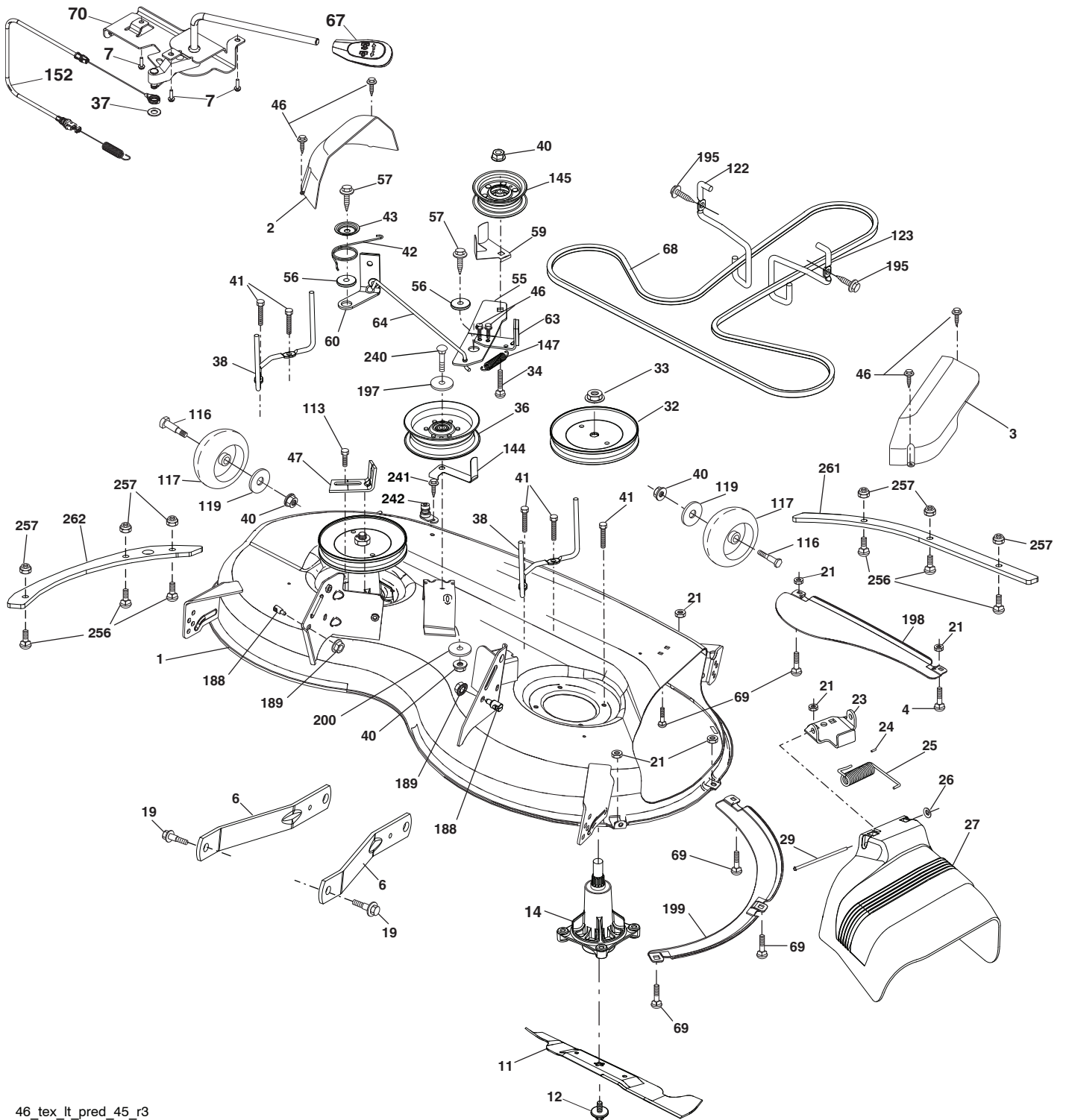

46_tex_lt_pred_45_r3

**TRACTOR - MODEL NO. TS 146X (96043030100), PRODUCT NO. 960 43 03-01
MOWER DECK**

KEY PART NO. NO.	DESCRIPTION	KEY PART NO. NO.	DESCRIPTION		
1	586 35 23-01	Kit SVC Deck Weldment	64	532 40 51-38	Linkage Brake
2	532 40 55-06	Cover Mandrel RH	67	532 40 30-12	Handle, Clutch Cable
3	532 40 55-07	Cover Mandrel LH	68	532 40 51-43	V-Belt
4	596 03 05-01	Screw, Hex, Hd, 5/16-18 unc x 3/4	69	596 13 64-01	Bolt, Cup, Head, 5/16-18 x 5/8
6	532 19 51-86	Arm Suspension	70	532 19 99-72	Clutch Asm. Cable
7	596 32 17-01	Screw, #10 x 0.750, Bos, Thread	113	817 00 05-10	Screw 5/16-18
11	532 40 53-80	Blade Mower Hi Lift	116	596 43 44-04	Bolt, Shoulder, 3/8-16 x 3-5/8"
12	584 30 93-01	Screw Sems 7/16-20 x 1 Hx Hd	117	589 52 73-01	Wheel, Gauge
14	587 81 97-01	Kit, Mandrel, Nongreaseable, Tall (includes mandrel and bolts)	119	596 13 49-01	Washer, Plain, 3/8 x 7/8
19	532 19 65-39	Bolt, Shoulder	122	532 19 72-58	Keeper Belt Eng. LH
21	596 04 05-01	Nut, Lock, Hex, Prvl, 5/16-18	123	532 19 72-59	Keeper Belt Eng. RH
23	532 19 25-57	Bracket, Deflector	144	532 19 92-04	Keeper Belt
24	532 10 53-04	Cap, Sleeve	145	532 19 31-97	Pulley Idler
25	532 19 70-26	Spring, Torsion, Deflector	147	532 40 18-72	Spring Return
26	532 11 04-52	Nut, Push	152	584 24 35-01	Cable Clutch Manual w/Spr.
27	532 40 53-57	Shield, Deflector	188	532 19 51-61	Stud Fastener
29	595 29 70-01	Rod, Hinge	189	596 13 57-01	Nut, Lock, Prvl, Torq, 5/16-18 x .68
32	532 19 74-73	Pulley, Mandrel	195	817 00 06-12	Screw 3/8-16 x 3/4
33	596 13 48-01	Nut, Hex, 9/16-18 x 1.010	197	596 13 32-01	Washer, 13/32 x 13/16 x 12 Ga.
34	596 13 61-01	Bolt, Cup, Head, 3/8-16 x 1-1/2"	198	532 40 31-49	Baffle Center Front
36	532 19 73-79	Pulley, Idler, Flat	199	532 40 31-50	Baffle Front RH
37	819 13 13-16	Washer 13/32 x 13/16 x 16 Ga.	200	532 41 35-24	Washer 13/32 x 1 x 1/2 11 Ga.
38	589 67 61-02	Keeper Belt LH Mandrel	240	874 52 06-36	Bolt 3/8-16 unc x 2-1/4 Gr. 5
40	873 90 06-00	Nut, Lock Flg. 3/8-16 unc	241	532 15 29-27	Screw
41	584 95 39-01	BoxHexWasherHead313-18x1.19	242	532 41 55-98	Washout Port
42	532 19 84-10	Spring Torsion Brake	256	596 23 84-01	Bolt, Carr. 1/4-20 x 3/4 Gr. 5 Clrzn
43	532 19 72-56	Spring Torsion Retainer	257	873 90 04-00	Nut Hex Flange 1/4-20 unc
46	532 13 77-29	Screw	261	589 48 18-05	Plate Reinforcement Front
47	532 19 72-50	Bracket Clutch Cable	262	589 48 20-05	Plate Reinforcement Side
55	532 19 72-49	Arm, Idler	--	532 41 64-05	Quick Connect Coupling
56	532 19 90-92	Spacer, Retainer	--	586 05 90-01	Replacement Mower, Complete
57	817 00 06-16	Screw Hexwsh Thd 3/8-16 x 1			
59	532 14 10-43	Guard, Tuv Idler (94)			
60	532 19 94-71	Arm Brake Mower LH			
63	532 19 94-77	Arm Brake Mower			

NOTE: All component dimensions given in U.S. inches
1 inch = 25.4 mm

**TRACTOR - MODEL NO. TS 146X (96043030100), PRODUCT NO. 960 43 03-01
MOWER LIFT**

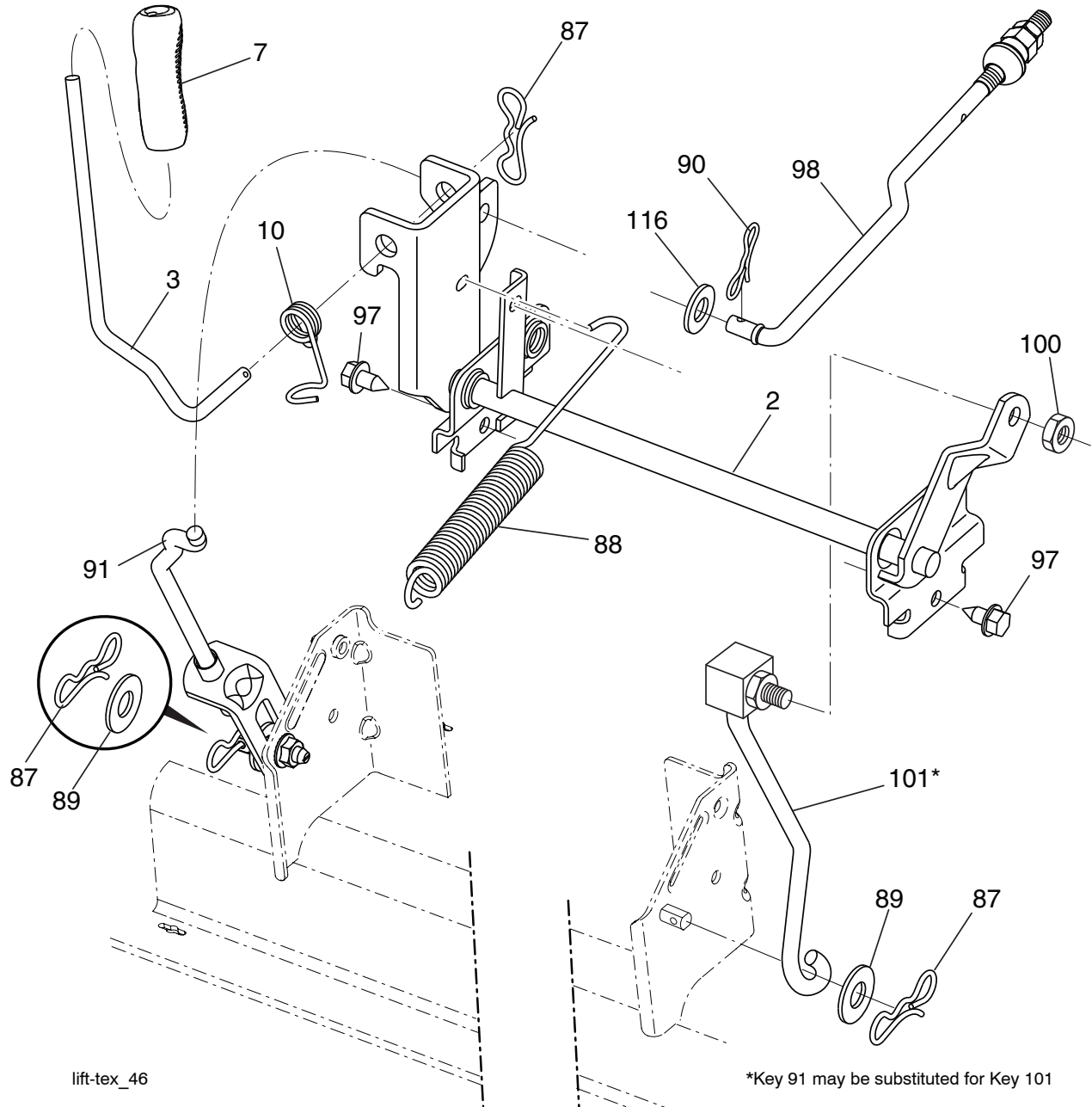

lift-tex_46

*Key 91 may be substituted for Key 101

KEY NO.	PART NO.	DESCRIPTION
2	532 42 20-27	Shaft Asm., Lift
3	594 01 80-01	Lever, Lift, Handle
7	580 96 23-01	Grip, Lever
10	532 19 63-14	Spring Torsion
87	532 19 42-09	Pin Cotter 7/16 Bow Tie Lock
88	532 41 07-10	Spring Lift Assist
89	819 19 19-12	Washer Clear Zinc
90	532 19 42-08	Pin Cotter 5/16 Bow Tie Lock
91	589 46 48-03	Link, Assy, Lift, Rear

KEY NO.	PART NO.	DESCRIPTION
97	817 00 06-12	Screw 3/8-16 x .75 Smsgml Tap/R.Z
98	581 50 69-03	Link, Assy, Front, Mwr, Susp
100	595 30 59-01	Nut, Hex, Locknut, 3/8-16
101	532 40 70-03	Link Asm. Fixed
116	594 97 65-01	Washer 15/32 x 15/16 16 x .065

NOTE: All component dimensions given in U.S. inches
1 inch = 25.4 mm

TRACTOR - MODEL NO. TS 146X (96043030100), PRODUCT NO. 960 43 03-01 SEAT ASSEMBLY

*OPTIONAL

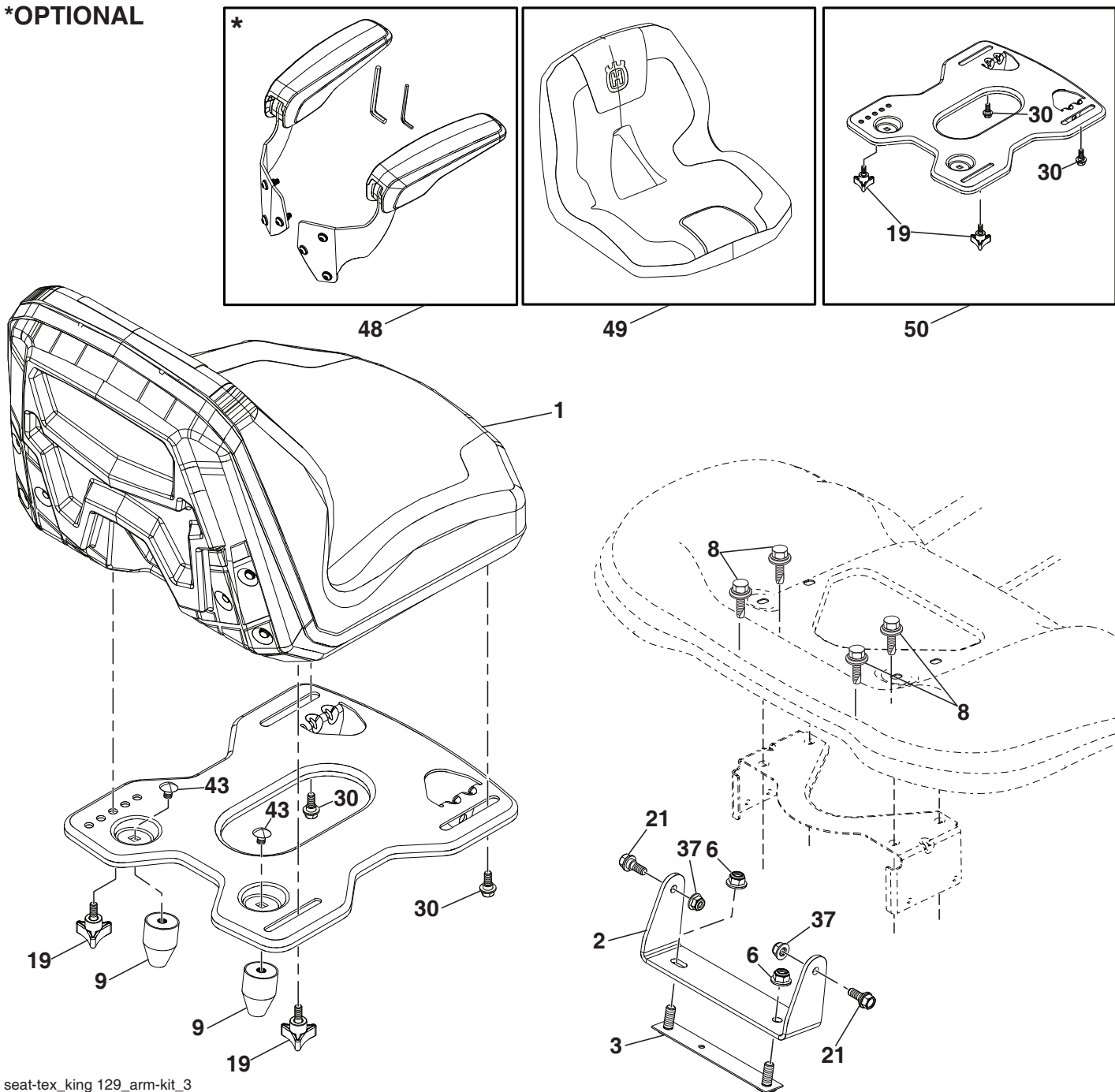

seat-tex_king 129_arm-kit_3

KEY NO.	PART NO.	DESCRIPTION
1	597 65 81-01	Seat, SK150/129 w/o Armrests (includes seat cover key# 49)
2	597 32 99-02	Bracket, PNT, PVT, FNDR, Seat EDIP
3	590 77 76-02	Bracket Asm, Reinf. FNDR, EDIP
6	521 99 65-02	Nut, Hex, Lock w/Flange 3/8-16
8	532 17 18-77	Bolt 5/16-18 unc x 3/4 w/Sems
9	597 78 51-01	Bumper, Rubber, Isolator
19	597 78 31-01	Knob, 3 Wing 5/16-18, CLR, ZN
21	596 24 07-01	Bolt, Hex 5/16-18 x 21/32

KEY NO.	PART NO.	DESCRIPTION
30	597 78-18-01	Bolt, Hex, Should 5/16-18 unc ZPB
37	594 94 44-01	Nut, Hexagon, Flange 5/16-18
43	597 86 93-01	Bolt, Carri, Cqur 3/8 x .45, CLR, ZN
48	597 65 82-03	Service Kit, 15", Seat Arm
49	597 95 94-01	Cover, Husq. 15", (SK129) Seat
50	598 00 16-01	Service, Kit, Seat Pan (includes all components illustrated in box for Key# 50)

NOTE: All component dimensions given in U.S. inches
1 inch = 25.4 mm

**TRACTOR - MODEL NO. TS 146X (96043030100), PRODUCT NO. 960 43 03-01
DECALS**

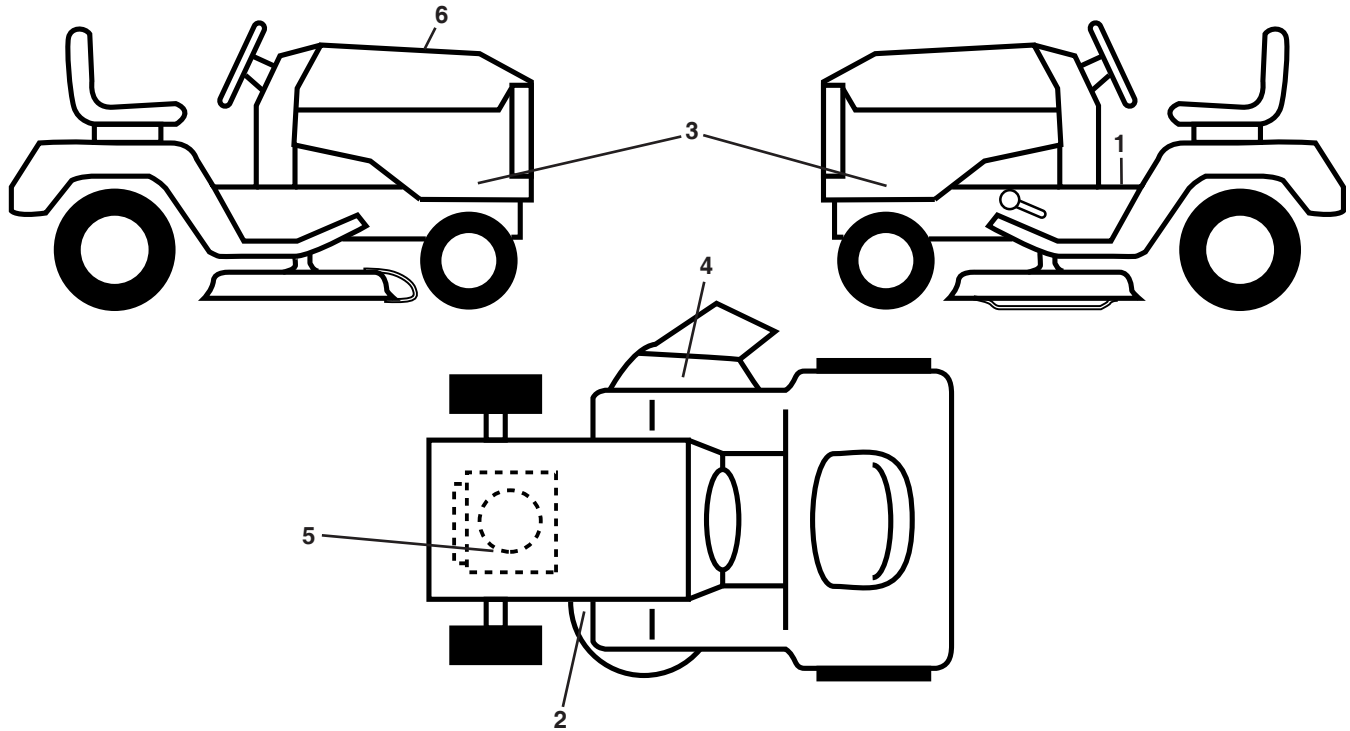

KEY NO.	PART NO.	DESCRIPTION	KEY NO.	PART NO.	DESCRIPTION
1	581 57 90-01	Decal, Fender Warning	--	532 43 96-81	Pad, Footrest, LH
2	581 58 00-01	Decal, Mower V-Belt Schematic	--	532 43 96-82	Pad, Footrest, RH
3	597 92 98-01	Decal, Hood Panel SD	--	114 20 19-49	Manual, Operators (English/Spanish)
4	584 90 46-01	Decal, Deflect. Warning	--	114 20 20-32	Manual, Operators (French)
5	586 00 06-01	Decal, Engine B&S	--	114 17 02-49	Manual, Parts (English/Spanish)
6	598 00 18-01	Decal, Replacement	--	114 17 03-32	Manual, Parts (French)
--	581 72 48-01	Decal, Bypass	--	587 71 00-26	Manual, QSG (English/Spanish)
			--	587 71 01-26	Manual, QSG (English/French)

WHEELS AND TIRES

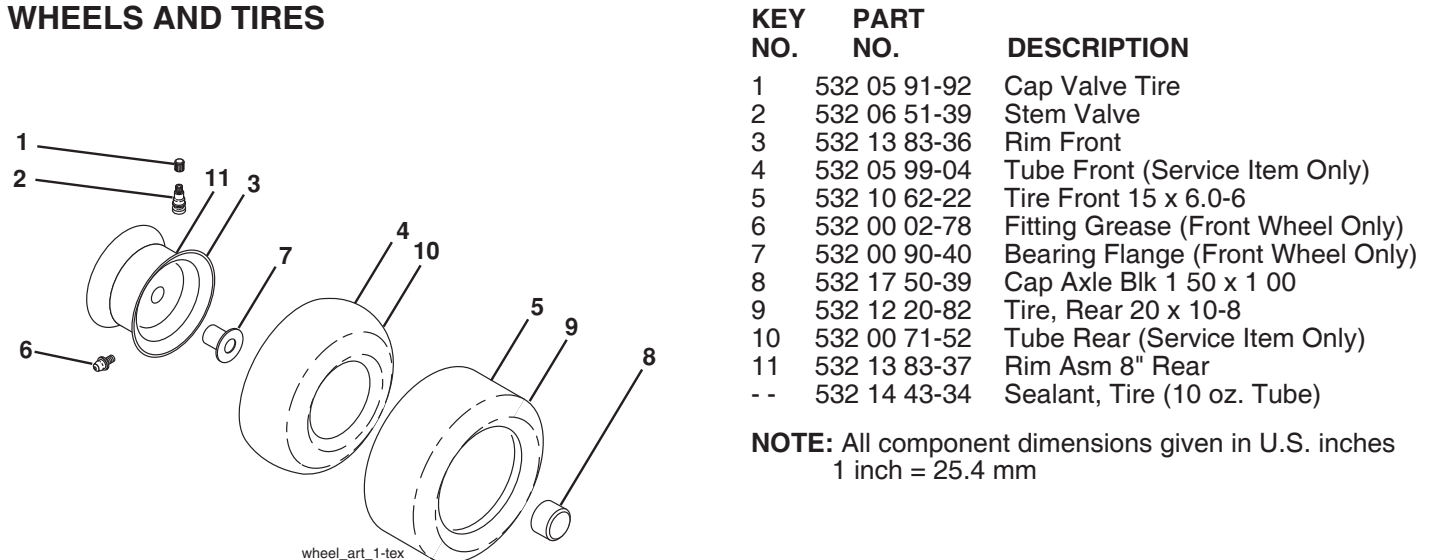

KEY NO.	PART NO.	DESCRIPTION
1	532 05 91-92	Cap Valve Tire
2	532 06 51-39	Stem Valve
3	532 13 83-36	Rim Front
4	532 05 99-04	Tube Front (Service Item Only)
5	532 10 62-22	Tire Front 15 x 6.0-6
6	532 00 02-78	Fitting Grease (Front Wheel Only)
7	532 00 90-40	Bearing Flange (Front Wheel Only)
8	532 17 50-39	Cap Axle Blk 1 50 x 1 00
9	532 12 20-82	Tire, Rear 20 x 10-8
10	532 00 71-52	Tube Rear (Service Item Only)
11	532 13 83-37	Rim Asm 8" Rear
--	532 14 43-34	Sealant, Tire (10 oz. Tube)

NOTE: All component dimensions given in U.S. inches
1 inch = 25.4 mm

TRACTOR - MODELO NO. TS 146X (96043030100), PRODUCTO NO. 960 43 03-01

DIAGRAMA

SCH11-s

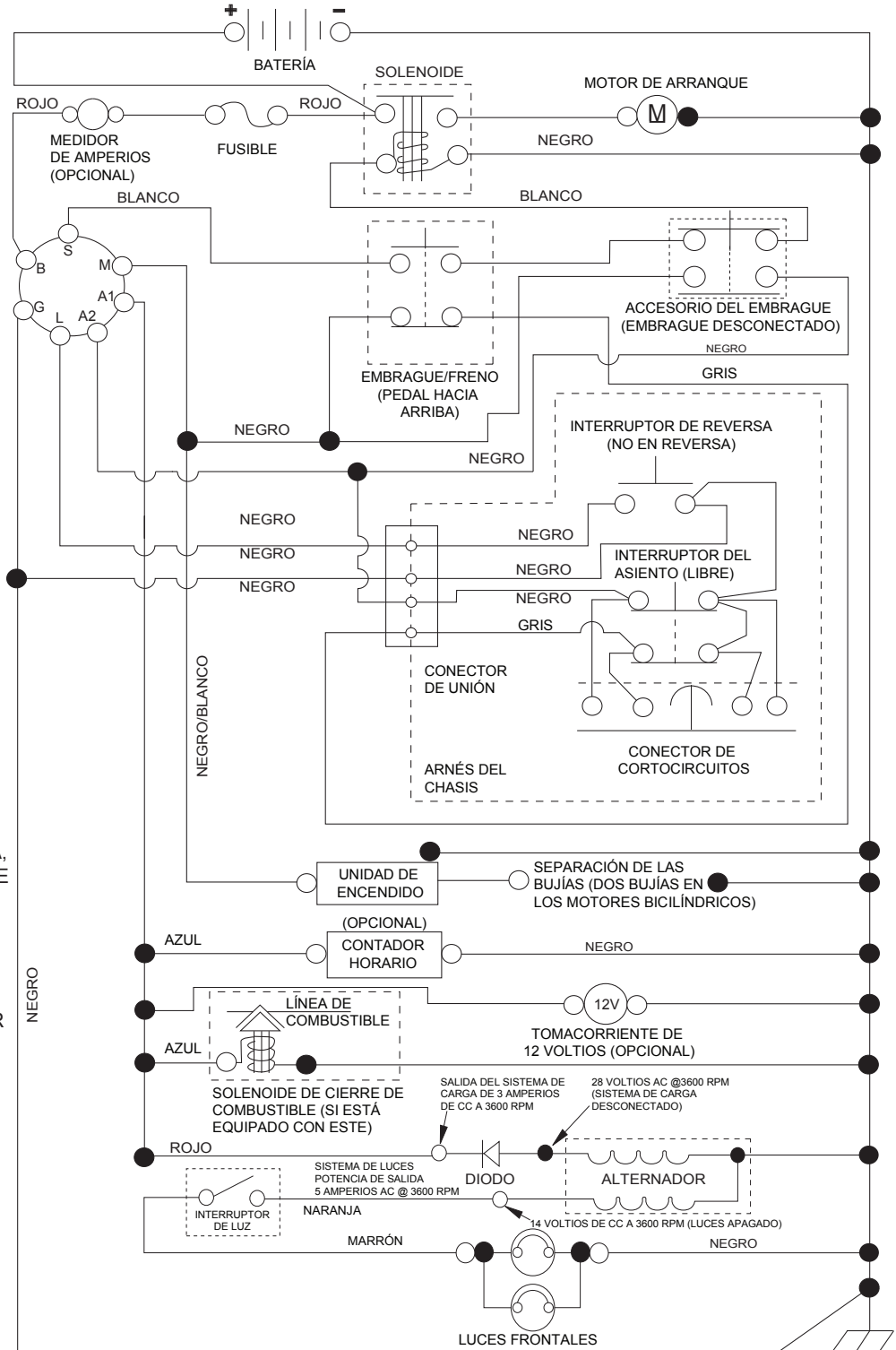

NOTAS:
 QUE SU TRACTOR ES EQUIPADO CON UN SISTEMA ESPECIAL DE ALTERNADOR. LAS LUCES NO SON CONECTADAS A LA BATERIA, PERO TIENEN SU PROPIA FUENTE ELECTRICA. A CAUSA DE ESTO, EL BRILLO DE LAS LUCES CAMBIARA CON LA VELOCIDAD DE MOTOR. EN LENTO, LAS LUCES NO SON COMO BRILLANTES. CUANDO EL MOTOR ES ACELERADO, LA LUZ CONSEGUIRÁ MÁS BRILLANTE.

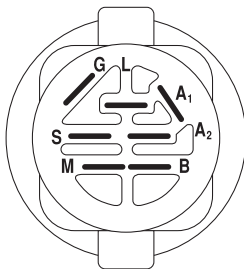

INTERRUPTOR DE ENCENDIDO

POSICIÓN	CIRCUITO «MARCA»
APAGADO	M+G+A1
PONER EN FUNCIONAMIENTO/ANULAR	B+A1
PONER EN FUNCIONAMIENTO	B+A1 L+A2
ARRANCAR	B + S + A1

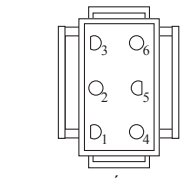

CONEXIÓN DEL ARNÉS DEL CHASIS (LATERAL QUE COINCIDA)

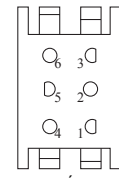

CONEXIÓN PARA EL ARNÉS DEL TABLERO (LATERAL QUE COINCIDA)

NOTA SOBRE LAS ABRAZADERAS DE AISLAMIENTO DEL CABLEADO: SI SE QUITAN LAS ABRAZADERAS DE AISLAMIENTO DEL CABLEADO PARA HACER EL MANTENIMIENTO DE LA UNIDAD, SE LAS DEBERÁ INSTALAR NUEVAMENTE PARA PROTEGER EL CABLEADO ADECUADAMENTE.

● CONEXIONES NO DESMONTABLES

○ CONEXIONES DESMONTABLES

TRACTOR - MODELO NO. TS 146X (96043030100), PRODUCTO NO. 960 43 03-01
DIAGRAMA ELÉCTRICO

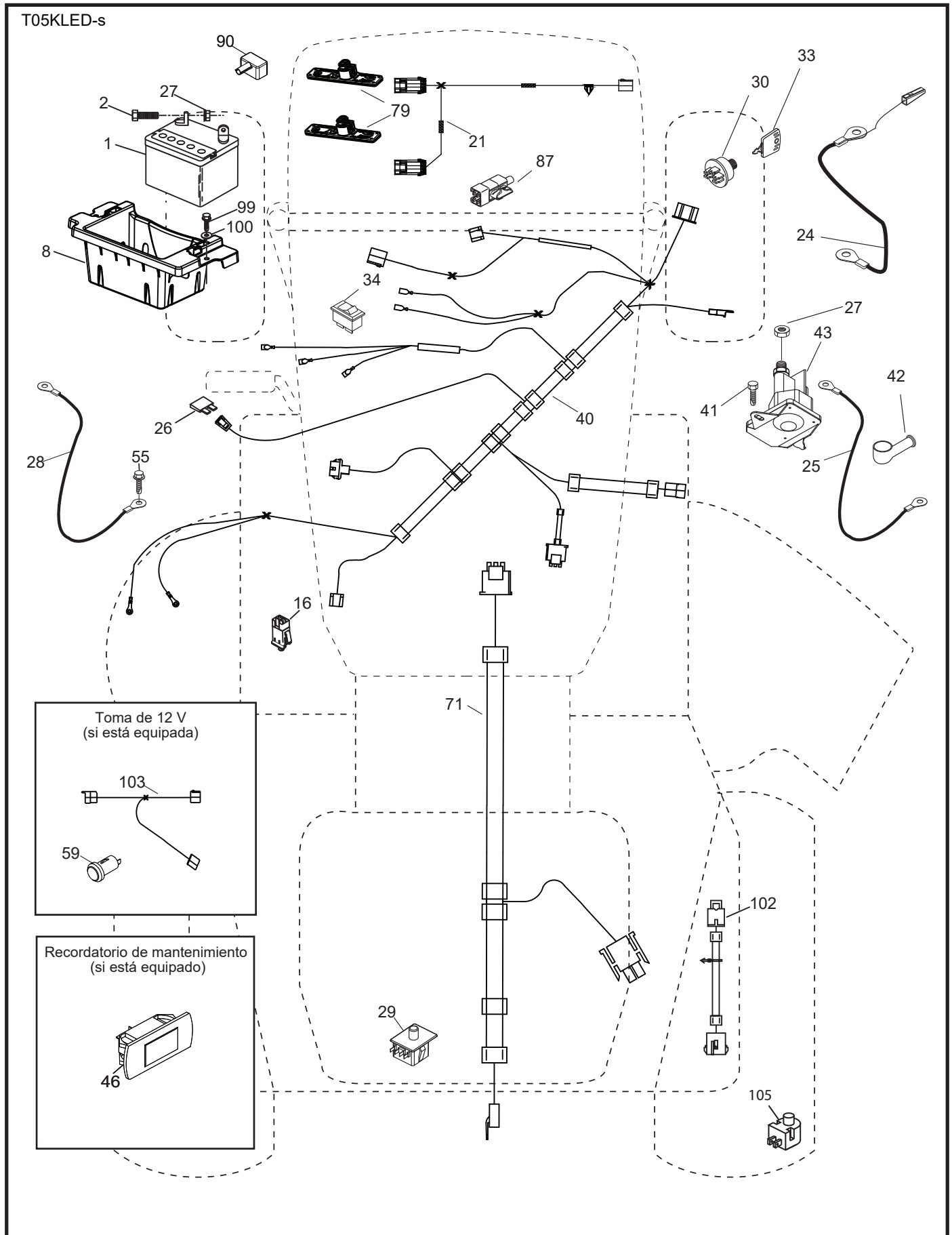

**TRACTOR - MODELO NO. TS 146X (96043030100), PRODUCTO NO. 960 43 03-01
DIAGRAMA ELÉCTRICO**

CÓDIGO PIEZA		DESCRIPCIÓN
No.	No.	
1	532 16 34-65	Batería
2	874 76 04-12	Perno de cabeza hexagonal de 1/4-20 x 3/4
8	587 20 51-01	Bandeja de batería
16	532 17 61-38	Interruptor corta corriente a presión
21	585 43 64-02	Arnés del luces LED
24	585 55 56-01	Cable de batería
25	585 55 55-01	Cable
26	532 17 51-58	Fusible
27	596 13 36-01	Tuerca de bloqueo, Keps,1/4-20
28	532 41 65-88	Cable a tierra
29	532 19 27-49	Interruptor del asiento
30	532 19 33-50	Interruptor de encendido
33	532 41 19-33	Llave/cadena
34	532 11 07-12	Interruptor de luz/de restauración
40	501 13 30-01	Cableado del tablero de encendido
41	817 72 04-08	Tornillo 1/-20 x 1/2
42	532 13 15-63	Cubierta del terminal
43	582 04 28-02	Solenoide
46	594 91 91-01	Horómetro, recordatorio de SRV
55	817 06 05-12	Tornillo de 5/16-18 x 3/4
71	532 19 42-76	Cableado de encendido
79	597 52 30-01	Luces de tira de LED
87	532 19 78-02	Interruptor corta corriente del cable de embrague
90	532 43 53-95	Tapa de los bornes de la batería
99	517 67 04-12	Tornillo
100	596 13 53-01	Arandela, 9/32 x 7/8.Clr.zn
102	532 40 44-54	Cableado
105	532 40 75-68	Interruptor

NOTA: Las dimensiones de todos los componentes están expresadas en pulgadas americanas. 1 pulgada = 25,4 mm

TRACTOR - MODELO NO. TS 146X (96043030100), PRODUCTO NO. 960 43 03-01
CHASIS

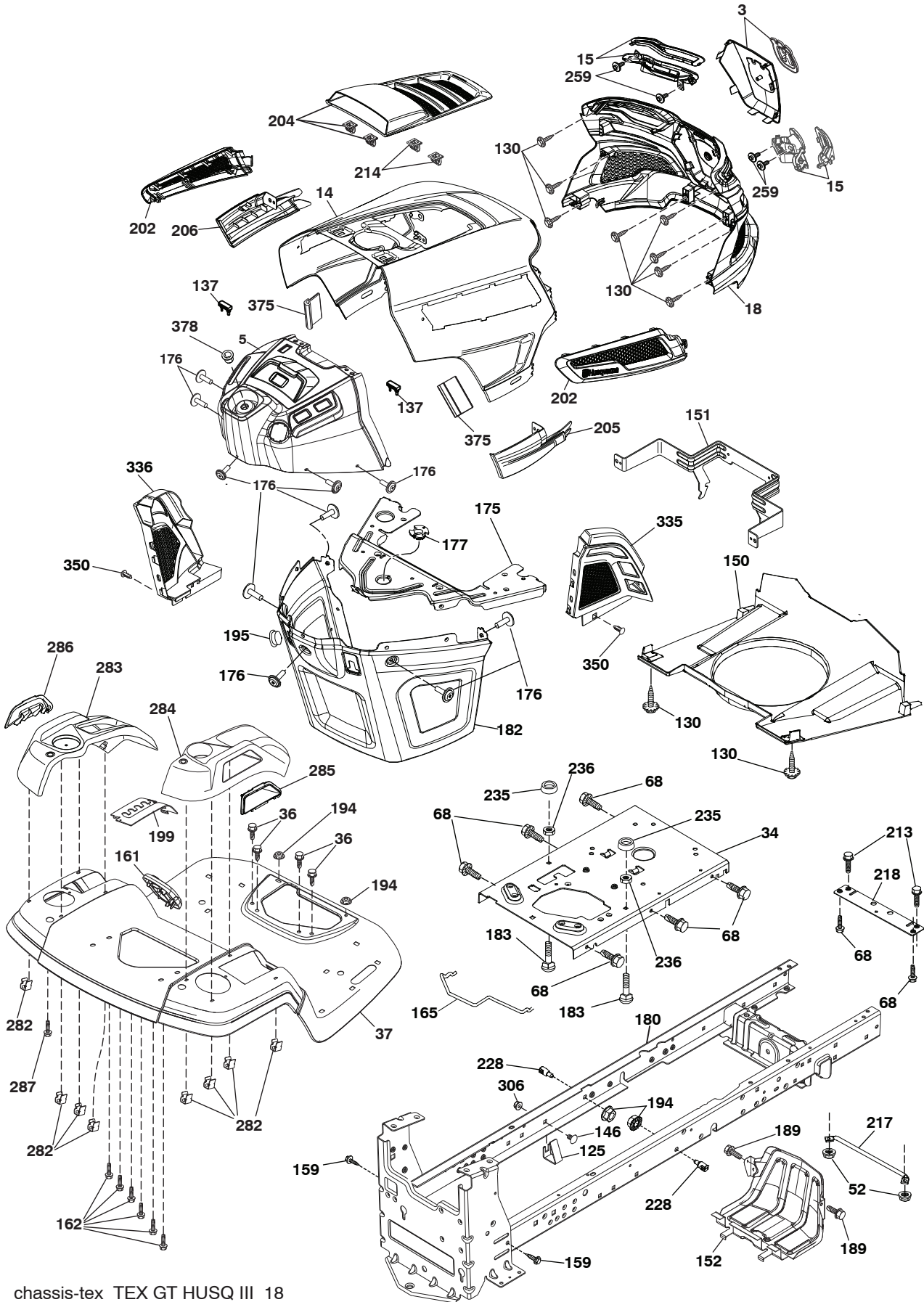

chassis-tex_TEX GT HUSQ III_18

TRACTOR - MODELO NO. TS 146X (96043030100), PRODUCTO NO. 960 43 03-01

CHASIS

CÓDIGO PIEZA		DESCRIPCIÓN	CÓDIGO PIEZA		DESCRIPCIÓN
No.	No.		No.	No.	
3	597 68 82-01	Kit de logotipo (Incluye aplique y emblema.)	199	532 41 34-85	Chapa cubierta
5	590 74 88-23	Tablero	202	597 86 77-01	Kit, ventilación lateral, LI y LD (incluye ventilaciones laterales LH / LD)
14	532 44 11-77	Capota			
15	597 86 79-01	Kit HUS GT3 faro LED (incluye lente LI/LD y carcasa LI/LD)	204	597 40 80-01	Kit, ventilación parte superior, LI y LD (incluye ventilaciones laterales LH / LD)
18	597 40 71-02	Parrilla			
34	580 91 08-01	Chapa Motor	205	532 43 97-30	Camisa de Capota (LD)
36	817 06 05-12	Tornillo de 5/16-18 x 3/4	206	532 43 97-29	Camisa de Capota (LI)
37	532 44 11-78	Guardabarros	213	596 03 05-01	Tornillo, Hex, Hd, 5/16-18 unc x 3/4
52	596 04 05-01	Tuerca, cerradura, hex., Prvl, 5/16-18	214	532 19 91-45	Cierre
68	596 03 07-01	Tornillo, hexágono, 5/16-18 x 1/2	217	532 40 91-67	Varilla giratoria
125	581 68 48-01	Línea de combustible	218	532 19 63-95	Tope
130	596 32 17-01	Tornillo, #10 x 0.750, Bos	228	532 19 51-61	Sujetador del travesaño
137	532 40 75-90	Cubierta Tablero	235	596 56 42-01	Espaciador, guardabarros, Clr, Zn
146	581 85 79-01	Perno de RDHD SHT SQNK 3/8-16 x 5/8	236	873 93 05-00	Tuerca de presión 5/16-18 unc
150	532 43 97-74	Cubierta térmica del conducto	259	596 43 40-01	Tornillo #10.10 x 0.500, Bos
151	532 43 66-70	Soporte	282	532 41 41-10	Pinzas de retención
152	532 43 98-70	Protector contra oscurecimiento	283	532 43 98-61	Consola de control
159	817 00 06-12	Tornillo 3/8-16 x 3/4	284	532 43 98-23	Consola cubierta de levantamiento
161	532 43 97-81	Combustible de ventana	285	532 41 63-15	Consola de inserto (LI)
162	596 13 41-01	Tornillo, Hex, Tap, 1/4-15 x 1/2	286	532 41 63-17	Consola de inserto (LD)
165	532 19 68-26	Soporte trasero	287	817 60 04-06	Tornillo 1/4 - 20 x 3/8
175	590 60 77-02	Travesaño	306	873 90 06-00	Tuerca de presión 3/8-16 unc
176	532 40 07-76	Tornillo de 10-24 x 5/8	335	532 44 82-04	Cubierta LD
177	532 19 52-28	Buje de dirección	336	532 44 53-09	Cubierta LI
180	532 19 54-57	Chasis	350	532 44 51-43	Clip del árbol de navidad
182	532 40 68-59	Tablero inferior	375	586 90 82-01	Cubierta Capota
183	595 30 57-01	Tornillo, hexágono, 5/16-18 x 1-1/4	378	590 84 98-01	Buje de con brida el plastico
189	817 00 05-12	Tornillo 5/16-18 x 3/4			
194	596 13 57-01	Bloqueo de la tuerca, Prvl, Torq, 5/16-18 x .68			
195	532 40 41-37	Tapón			

NOTA: Las dimensiones de todos los componentes están expresadas en pulgadas americanas. 1 pulgada = 25,4 mm

**TRACTOR - MODELO NO. TS 146X (96043030100), PRODUCTO NO. 960 43 03-01
TRANSMISIÓN**

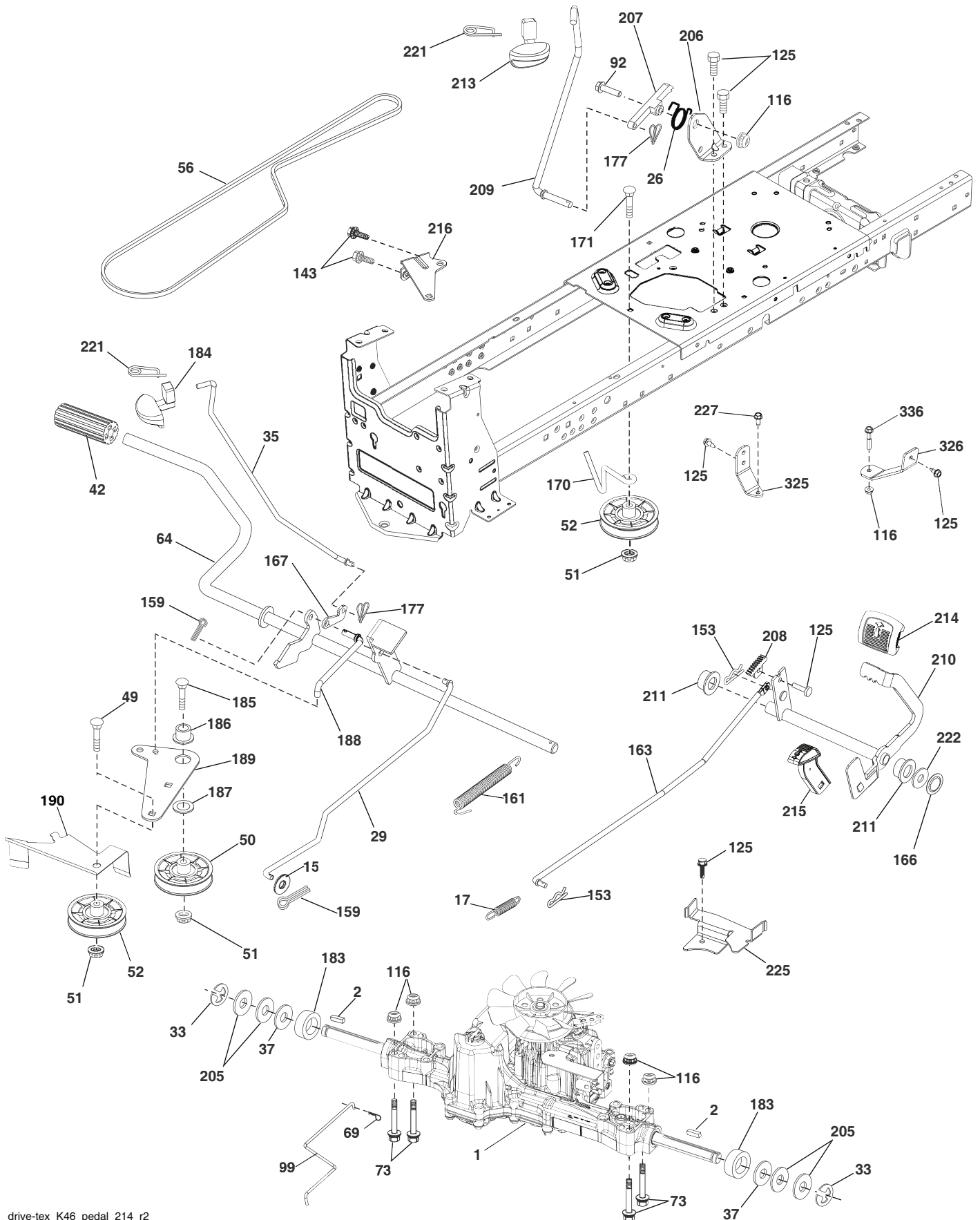

drive-tex_K46_pedal_214_r2

TRACTOR - MODELO NO. TS 146X (96043030100), PRODUCTO NO. 960 43 03-01

TRANSMISIÓN

CÓDIGO No.	PIEZA No.	DESCRIPCIÓN	CÓDIGO No.	PIEZA No.	DESCRIPCIÓN
1	---	Transeje, TUFFTORQ K46BT (426120) (Haga el pedido de las piezas al fabricante del transeje.)	177	587 22 53-01	Abrazadera de retención 1 In.
2	532 12 35-83	Cuña	183	532 13 70-57	Separador del eje
15	819 13 13-16	Arandela de 13/32 x 13/16 x calibre 16	184	587 65 37-01	Manija del freno de mano
17	532 41 36-78	Resorte de freno	185	872 11 06-22	Perno
26	532 19 96-79	Crucero con retorno de muelle	186	532 19 43-21	Espaciador de retención
29	532 40 38-06	Varilla del freno	187	596 13 55-01	Arandela, 13/32 x 2, claro, Zinc
33	812 00 00-01	Aro E	188	582 21 70-01	Mecanismo de desplazamiento de la varilla de mando del embrague del largo
35	590 60 59-02	Varilla del freno de mano	189	532 19 43-17	Palanca acodada del mecanismo de desplazamiento
37	532 18 89-67	Arandela	190	532 19 43-18	Sujetador de la palanca acodada del mecanismo de desplazamiento
42	532 00 88-83	Cubierta del pedal	205	532 12 17-48	Arandela de 25/32 x 1-5/8 calibre 16
49	596 13 62-01	Perno, cabeza de copa, 3/8-16 x 3/4	206	532 44 85-96	Soporte de montaje del bloqueo del crucero
50	532 19 43-27	Polea loca plana	207	587 03 14-02	Bloqueo del control del crucero
51	873 90 06-00	Tuerca de presión de 3/8-16	208	596 56 41-01	Engranaje del sector de control del crucero
52	532 19 43-26	Polea loca con ranura en V con un desplazamiento	209	590 52 78-02	Varilla de control del crucero
56	592 85 52-01	Correa trapezoidal de la transmisión	210	532 40 09-80	Ensamble del control del pedal
64	532 19 78-65	Ensamble del eje Control del pedal de freno	211	532 12 01-83	Rodamiento de nylon
69	532 42 33-03	Clavija	213	532 40 31-19	Perilla de control del crucero
73	596 13 65-01	Perno, cabeza hexagonal, 5/16-18 x 1-1/2	214	532 42 12-63	Forro del pedal para avanzar
92	595 30 57-01	Tornillo, hexágono, 5/16-18 x 1-1/4	215	586 60 65-02	Forro del pedal para retroceder
99	582 40 45-01	Varilla del ensamble con resorte de desviación	216	532 19 61-31	Soporte del Polea
116	596 13 57-01	Bloqueo de la tuerca, Prvl, Torq, 5/16-18 x .68	221	532 40 31-87	Abrazadera de retención del resorte de la manija
125	817 00 05-12	Tornillo de 5/16-18 x 3/4	222	879 21 20-10	Arandela de 21/32 x 1-1/4 calibre 10
143	596 03 07-01	Tornillo, hexágono, 5/16-18 x 1/2	225	532 40 33-19	Sujetador de la correa
153	532 00 44-97	Retén del resorte	227	596 13 59-01	Perno hexagonal, 5/16-18 x 3/4, Clr, Znc
159	596 02 95-01	Alfiler, chaveta 1/8 Dia x 3/4	325	585 66 85-02	Soporte
161	532 10 57-09	Resorte de retorno del embrague	326	585 67 08-02	Soporte
163	593 86 10-01	Barra de control, K46/K57R	336	587 25 96-02	Perno 5/16 - 18 x 1-3/4
166	532 42 91-64	Tuerca de presión			
167	532 40 52-57	Pestillo del freno de mano			
170	532 19 43-22	Sujetador de la correa			
171	596 13 63-01	Perno, cabeza de copa, 3/8-16 x 2			

NOTA: Las dimensiones de todos los componentes están expresadas en pulgadas americanas. 1 pulgada = 25,4 mm

**TRACTOR - MODELO NO. TS 146X (96043030100), PRODUCTO NO. 960 43 03-01
MOTOR**

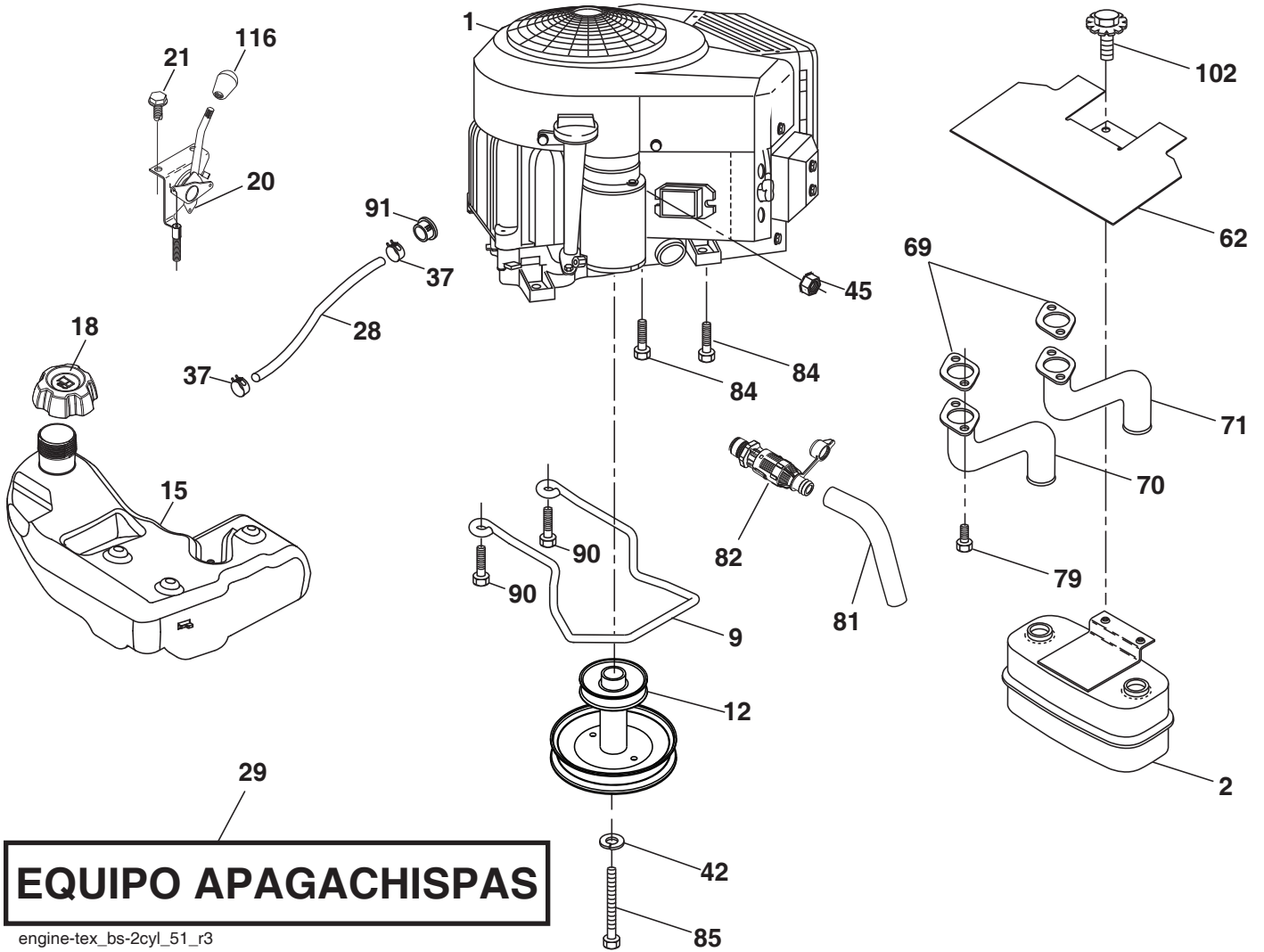

TRACTOR - MODELO NO. TS 146X (96043030100), PRODUCTO NO. 960 43 03-01 MOTOR

CÓDIGO No.	PIEZA No.	DESCRIPCIÓN
1	-----	Motor B&S modelo No. 40N677-0027-G1 (501709001) (Haga el pedido de las piezas al fabricante del motor.)
2	589 81 87-01	Silenciador
9	501 83 26-02	Ensamble del sujetador de la correa del motor
12	586 72 89-01	Polea del motor
15	532 43 80-28	Tanque de combustible
18	585 12 48-01	Ensamble de la tapa
20	587 24 27-01	Acelerador, 38
21	596 32 17-01	Tornillo, #10 x 0.750, Bos
28	532 40 11-35	Línea de combustible
29	532 13 71-80	Equipo apagachispas
37	532 12 34-87	Abrazadera de la manguera
42	596 23 89-01	Aredala, 7/16 In, Clr, Zn
45	596 13 36-01	Tuerca de bloqueo, Keps, 1/4-20
62	532 43 40-17	Protector
69	532 16 53-91	Junta
70	581 88 11-01	Tubo de escape LI
71	581 88 10-01	Tubo de escape LD
79	596 13 42-02	Tornillo, zócalo, 5/16-18 x 1, Clr, Zn
81	532 14 84-56	Tubo de fácil drenaje de aceite
82	532 42 82-87	Conector del drenaje de aceite
84	817 06 06-20	Tornillo 3/8-16 x 1-1/4
85	501 60 65-01	Perno 7/16-20 x 4 x Gr. 5-1.5
90	817 00 06-16	Tornillo 3/8-16 x 1
91	532 18 74-95	Buje
102	817 00 05-12	Tornillo 5/16-18 x 3/4
116	539 13 26-24	Botón

NOTA: Las dimensiones de todos los componentes están expresadas en pulgadas americanas. 1 pulgada = 25,4 mm

Para las piezas del servicio y de recambio del motor, llame el número gratis para su fabricante del motor enumerado abajo:

Briggs & Stratton 1-800-233-3723

Información de Clasificación de Potencia del Motor

La clasificación de potencia para un modelo de motor a gas en particular se designa de acuerdo al código J1940 de SAE (Sociedad de Ingenieros Automotrices) (Procedimiento de Clasificación de Potencia & Torque del Motor Pequeño), y la clasificación de desempeño ha sido obtenida y corregida de acuerdo con el código J1995 de SAE (Revisión 2002-05). Los valores de torque se obtienen a 3060 RPM; los valores de potencia se obtienen a 3600 RPM. La potencia bruta actual del motor será inferior y está afectada, entre otras cosas, por las condiciones ambientales operativas y la variabilidad de motor a motor. Dado ambos un amplio conjunto de productos en los cuales son puestos nuestros motores, y la variedad de emisiones ambientales aplicables al operar el equipo, el motor a gas no desarrollará la potencia nominal cuando sea usado en una parte del equipo acoplado (potencia real "en el-sitio" o potencia neta). Esta diferencia se debe a una variedad de factores que incluyen, pero que no están limitados a, accesorios (filtro de aire, sistema de escape, sistema de carga, sistema de enfriamiento, carburador, bomba de combustible, etc.) limitaciones de la aplicación, condiciones ambientales de operación (temperatura, humedad, altitud), y la variabilidad de motor a motor. Debido a las limitaciones, Briggs & Stratton puede sustituir este motor con clasificación de potencia más alta por esta serie de motor.

TRACTOR - MODELO NO. TS 146X (96043030100), PRODUCTO NO. 960 43 03-01
ENSAMBLE DE LA DIRECCIÓN

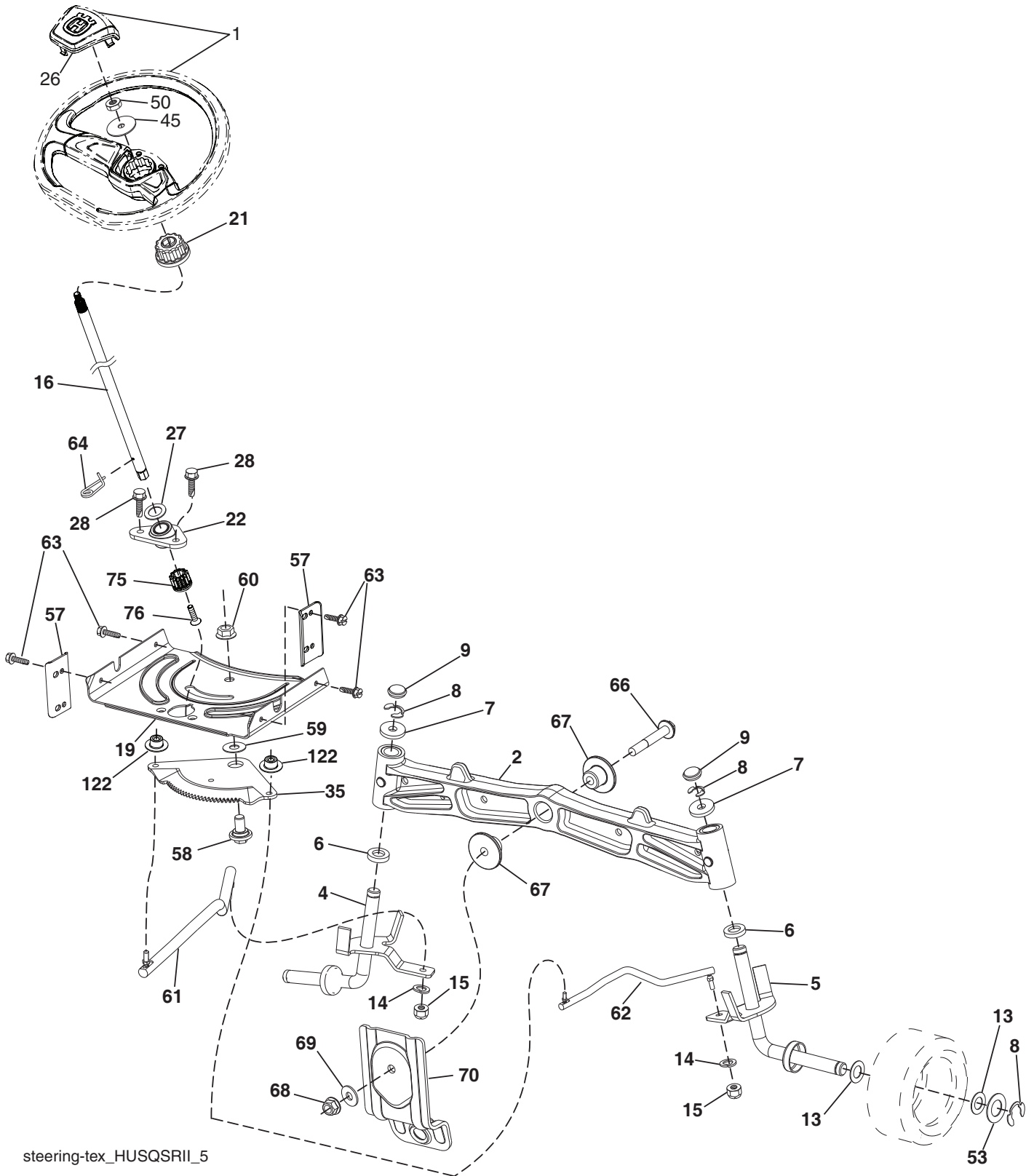

steering-tex_HUSQSR11_5

**TRACTOR - MODELO NO. TS 146X (96043030100), PRODUCTO NO. 960 43 03-01
ENSAMBLE DE LA DIRECCIÓN**

CÓDIGO No.	PIEZA No.	DESCRIPCIÓN
1	597 86 61-01	Kit, rueda, dirección (Incluye volante y tapa del volante)
2	532 19 59-68	Eje
4	532 40 30-87	Ensamble del husillo izquierdo
5	532 40 30-88	Ensamble del husillo derecho
6	532 00 62-66	Arandela .75 x 1.230
7	532 12 17-48	Arandela de 25/32 x 1-5/8 calibre 16
8	812 00 00-29	Abrazadera del aro No. T5304-75
9	532 12 12-32	Tapa del husillo
13	532 12 17-49	Arandela de 25/32 x 1-1/4 calibre 16
14	596 23 87-01	Arandela, resorte, cerradura, 381ID x, 680
15	873 54 06-00	Tuerca corona de presión de 3/8-24 unf
16	587 01 60-02	Eje de dirección
19	532 19 47-29	Placa de dirección
21	586 84 02-01	Adaptador del volante de dirección
22	585 02 98-02	Rodamiento
26	594 94 91-01	Inserto del volante de dirección
27	596 93 34-01	Arandela
28	817 00 06-12	Tornillo de 3/8-16 x 3/4
35	532 19 47-32	Engranaje del sector de la placa
45	587 01 64-01	Arandela 3/8 ID 2-3/8 OD calibre 12 PLTD
50	873 90 06-00	Tuerca 3/8-16 unc
53	532 18 89-67	Arandela reforzada de 793 x 1637 x 0,060
57	532 40 74-65	Tope superior del soporte
58	532 19 47-47	Perno de tope del sector del pivote CFM
59	532 19 47-48	Arandela de empuje del sector de dirección
60	873 97 10-00	Tuerca de presión con brida de 5/8-11
61	597 07 02-02	Barra de acoplamiento, LI, Adj, Std, Clrzn
62	597 07 03-02	Barra de acoplamiento, LD, Adj, Std, Clrzn
63	817 00 05-12	Tornillo de 5/16-18 x 3/4
64	532 19 98-49	Abrazadera de retención del resorte de la dirección
66	871 02 07-48	Perno de cabeza 7/16-14 x 3
67	532 19 47-37	Buje PM del eje delantero
68	873 90 07-00	Tuerca de presión con brida de 7/16-14 grado 5
69	532 19 91-62	Arandela de 1,5 x 0,505 x 0,118
70	585 33 88-01	Soporte de la plataforma delantera
75	580 68 37-01	Piñón
76	580 68 36-01	Tornillo
122	532 44 49-62	Tapas

NOTA: Las dimensiones de todos los componentes están expresadas en pulgadas americanas. 1 pulgada = 25,4 mm

TRACTOR - MODELO NO. TS 146X (96043030100), PRODUCTO NO. 960 43 03-01
PLATAFORMA DE LA CORTADORA DE CÉSPED

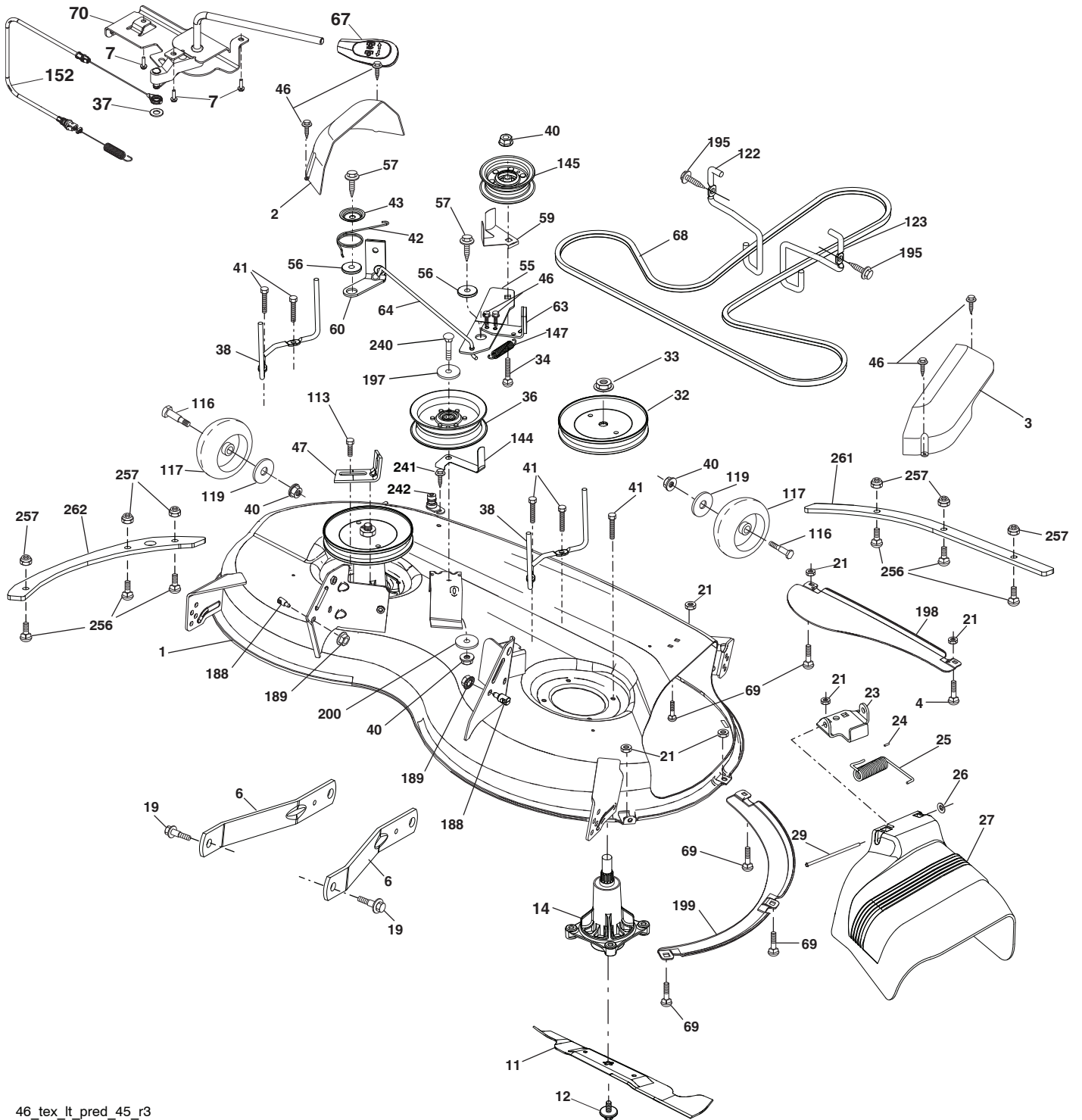

46_tex_lt_pred_45_r3

**TRACTOR - MODELO NO. TS 146X (96043030100), PRODUCTO NO. 960 43 03-01
PLATAFORMA DE LA CORTADORA DE CÉSPED**

CÓDIGO No.	PIEZA No.	DESCRIPCIÓN	CÓDIGO No.	PIEZA No.	DESCRIPCIÓN
1	586 35 23-01	Carcasa de la cortadora de césped	63	532 19 94-77	Brazo del freno de la cortadora de césped
2	532 40 55-06	Cubierta derecha del mandril	64	532 40 51-38	Varillaje del freno
3	532 40 55-07	Cubierta izquierda del mandril	67	532 40 30-12	Manija del cable de embrague
4	596 03 05-01	Tornillo hexagonal, Hd, 5/16-18 unc x 3/4	68	532 40 51-43	Correa trapezoidal
6	532 19 51-86	Brazo de la suspensión	69	596 13 64-01	Perno, cabeza de copa, 5/16-18 x 5/8
7	596 32 17-01	Tornillo , #10 x 0.750, Bos	70	532 19 99-72	Ensamble del embrague Manual
11	532 40 53-80	Cuchilla de la cortadora	113	817 00 05-10	Tornillo de 5/16-18
12	584 30 93-01	Tornillo 7/16-20 x 1	116	596 43 44-04	Perno, hombro, 3/8-16 x 3-5/8"
14	587 81 97-01	Conjunto, mandril, no engrasable, alto (incluye mandril asm y pernos)	117	589 52 73-01	Calibrador de la rueda
19	532 19 65-39	Perno de tope	119	596 13 49-01	Arandela, 3/8 x 7/8
21	596 04 05-01	Bloqueodelatuerca, Hex, Prvl, 5/16-18	122	532 19 72-58	Sujetador izquierdo de la correa del motor
23	532 19 25-57	Soporte del deflector	123	532 19 72-59	Sujetador derecho de la correa del motor
24	532 10 53-04	Tapa de la manga	144	532 19 92-04	Sujetador de la correa
25	532 19 70-26	Resorte de torsión del deflector	145	532 19 31-97	Polea loca
26	532 11 04-52	Tuerca de presión	147	532 40 18-72	Retorno del resorte
27	532 40 53-57	Protector del deflector	152	584 24 35-01	Cable de embrague manual con resorte
29	595 29 70-01	Varilla, bisagra	188	532 19 51-61	Sujetador del travesaño
32	532 19 74-73	Polea del mandril	189	596 13 57-01	Bloqueo de la tuerca, Prvl, Torq, 5/16-18 x .68
33	596 13 48-01	Tuerca hexagonal, 9/16-18 x 1.010	195	817 00 06-12	Tornillo de 3/8-16 x 3/4
34	596 13 61-01	Perno, cabeza de copa, 3/8-16 x 1-1/2"	197	596 13 32-01	Arandela, 13/32 x 13/16 x 12 Ga
36	532 19 73-79	Polea loca	198	532 40 31-49	Deflector delantero central
37	819 13 13-16	Arandela de 13/32 x 13/16 x calibre 16	199	532 40 31-50	Deflector delantero derecho
38	589 67 61-02	Sujetador de la correa izquierda del mandril	200	532 41 35-24	Arandela de 13/32 x 1 x 1/2 calibre 11
40	873 90 06-00	Tuerca de presión con brida de 3/8-16 unc	240	874 52 06-36	Perno 3/8-16 unc x 2-1/4
41	584 95 39-01	Arandela 313-18 x 1.19	241	532 15 29-27	Tornillo
42	532 19 84-10	Resorte de torsión del freno	242	532 41 55-98	Puerto de Lavado de la Cubierta
43	532 19 72-56	Resorte de torsión de retención	256	596 23 84-01	Perno 1/4-20 x 3/4 grado 5 Clrzn
46	532 13 77-29	Tornillo	257	873 90 04-00	Tuerca 1/4 x 20 unc
47	532 19 72-50	Soporte del cable de embrague	261	589 48 18-05	Frente de refuerzo de placa
55	532 19 72-49	Brazo de la polea	262	589 48 20-05	Lado de refuerzo de la placa
56	532 19 90-92	Espaciador de retención	--	532 41 64-05	Accesorio del conexion
57	817 00 06-16	Tornillo hexagonal con arandela de 3/8-16 x 1	--	586 05 90-01	Reemplazo de la cortadora de césped, completa
59	532 14 10-43	Dispositivo de protección de la polea (94)			
60	532 19 94-71	Brazo izquierdo del freno de la cortadora de césped			

NOTA: Las dimensiones de todos los componentes están expresadas en pulgadas americanas. 1 pulgada = 25,4 mm

**TRACTOR - MODELO NO. TS 146X (96043030100), PRODUCTO NO. 960 43 03-01
ELEVACIÓN DE LA CORTADORA DE CÉSPED**

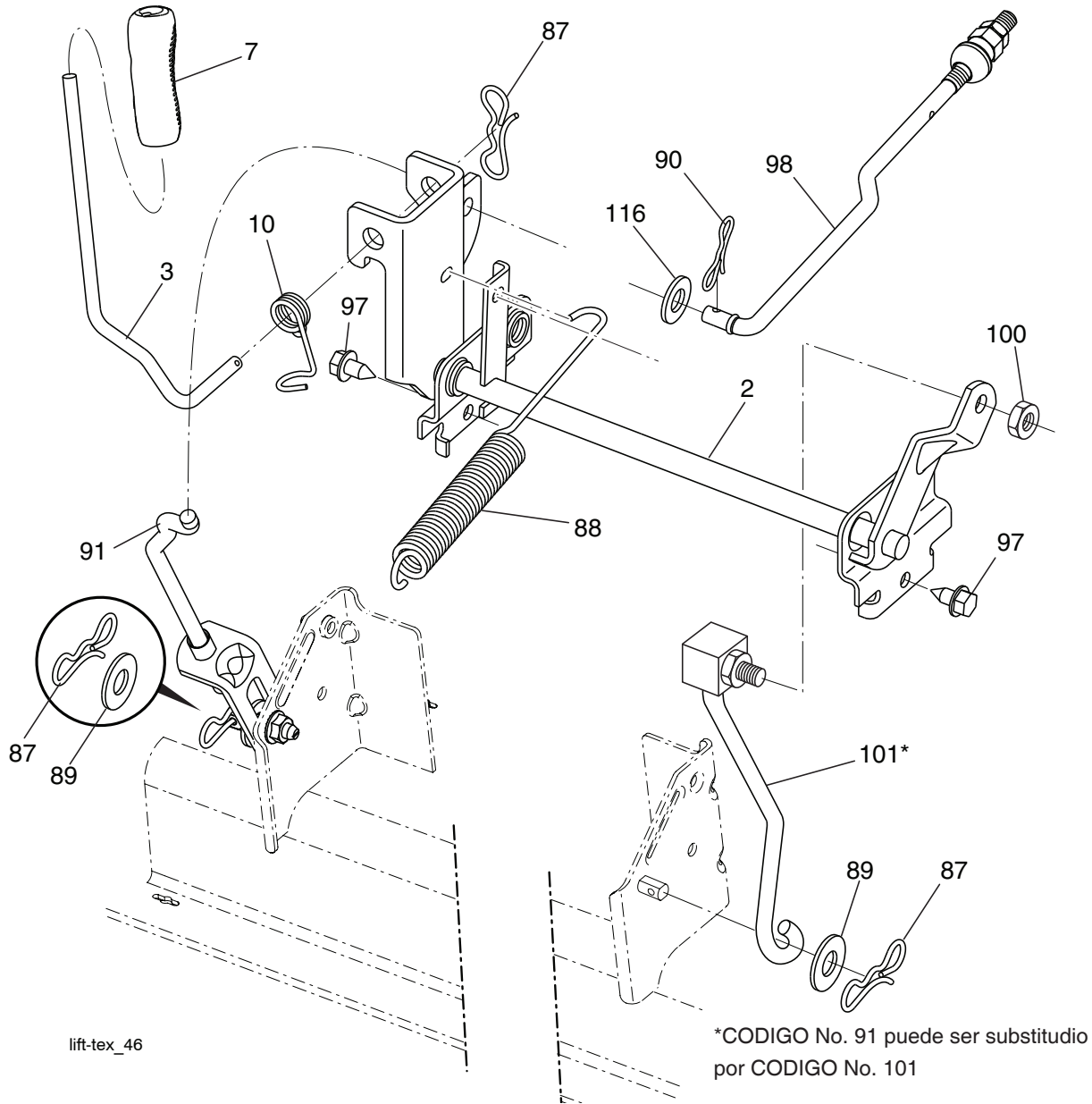

lift-tex_46

*CODIGO No. 91 puede ser substituido por CODIGO No. 101

CÓDIGO No.	PIEZA No.	DESCRIPCIÓN
2	532 42 20-27	Ensamble del eje de la elevación
3	594 01 80-01	Palanca, elevador, manija
7	580 96 23-01	Mango de la palanca
10	532 19 63-14	Resorte de torsión
87	532 19 42-09	Pasador de chaveta de 7/16 con bloqueo en forma de mariposa
88	532 41 07-10	Resorte de ayuda de la elevación
89	819 19 19-12	Arandela de zinc transparente
90	532 19 42-08	Pasador de chaveta de 5/16 con bloqueo en forma de mariposa
91	589 46 48-03	Enlace, montaje, elevador, trasero
97	817 00 06-12	Tornillo de 3/8-16 x 0,75

CÓDIGO No.	PIEZA No.	DESCRIPCIÓN
98	581 50 69-03	Enlace, montaje, frente, Mwr, Susp
100	595 30 59-01	Tuerca hexagonal, contratuerca, 3/8-16
101	532 40 70-03	Ensamble del acoplamiento Elevación fijo
116	594 97 65-01	Arandela 15/32 x 15/16 16 x .065

NOTA: Las dimensiones de todos los componentes están expresadas en pulgadas americanas. 1 pulgada = 25,4 mm

TRACTOR - MODELO NO. TS 146X (96043030100), PRODUCTO NO. 960 43 03-01 ENSAMBLE DEL ASIENTO

*OPCIONAL

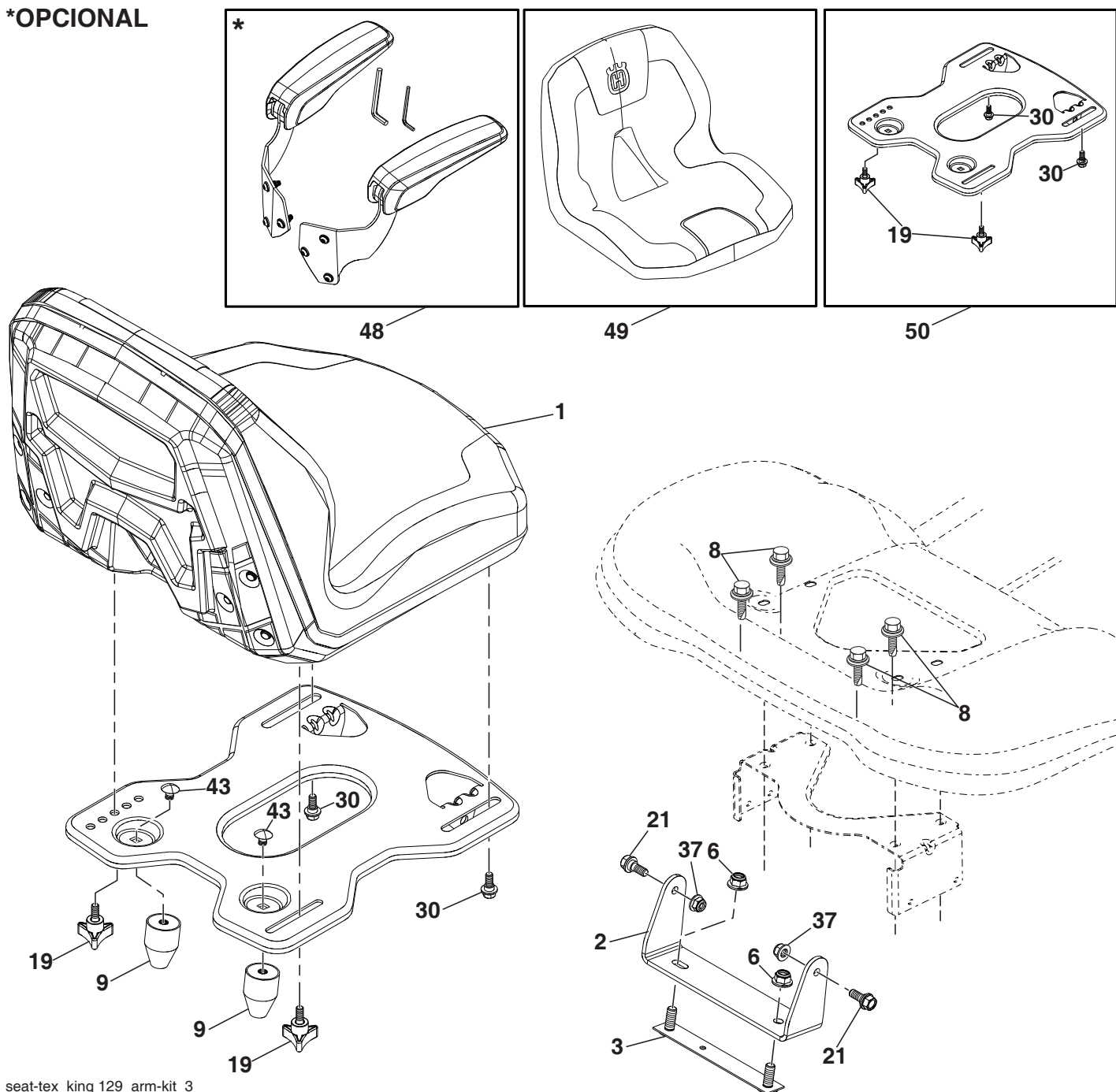

seat-tex_king 129_arm-kit_3

CÓDIGO No.	PIEZA No.	DESCRIPCIÓN
1	597 65 81-01	Asiento, SK150/129 w/o apoyabrazos
2	597 32 99-02	Soporte PNT, PVT, FNDR, asiento, EDIP
3	590 77 76-02	Refuerzo de montaje de soporte, FNDR, EDIP
6	521 99 65-02	Tuerca, hexagonal, bloqueo w/brida
8	532 17 18-77	Perno 5/16-18 unc x 3/4 w/Sems
9	597 78 51-01	Parachoques, caucho, aislador
19	597 78 31-01	Pomo, 3 alas 5/16-18, CLR, ZN
21	596 24 07-01	Perno hexagonal 5/16-18 x 21/32
30	597 78 18-01	Perno hexagonal hombro 5/16-18 unc ZPB
37	594 94 44-01	Tuerca hexagonal brida 5/16-18

CÓDIGO No.	PIEZA No.	DESCRIPCIÓN
43	597 86 93-01	Perno de carro cuadrado 3/8 x .45 CLR, ZN
48	597 65 82-03	Kit de servicio brazo de asiento de 15"
49	597 95 94-01	Funda de asiento Husqvarna 5 pulgadas (Sk129)
50	598 00 16-01	Kit de placa de montaje del asiento (incluye todos los componentes ilustrados en la caja para la Clave# 50)

NOTA: Las dimensiones de todos los componentes están expresadas en pulgadas americanas. 1 pulgada = 25,4 mm

**TRACTOR - MODELO NO. TS 146X (96043030100), PRODUCTO NO. 960 43 03-01
CALCOMANÍAS**

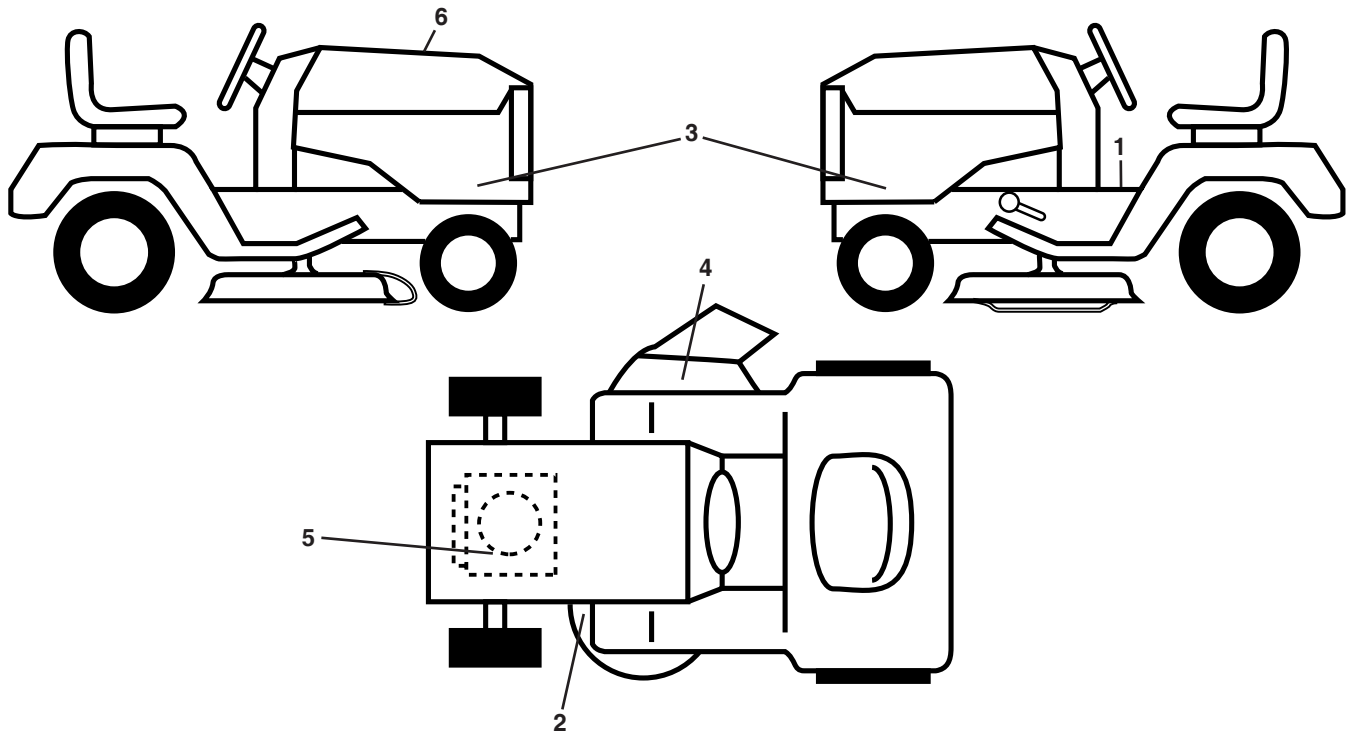

**CÓDIGO PIEZA
No. No.**

CÓDIGO PIEZA No.	No.	DESCRIPCIÓN
1	581 57 90-01	Calcomanía para el advertencia
2	581 58 00-01	Calcomanía del diagrama de la cortadora de césped
3	597 92 98-01	Calcomanía para el panel capota
4	584 90 46-01	Calcomanía advertencia
5	586 00 06-01	Calcomanía de motor B&S
6	598 00 18-01	Calcomanía de reemplazo
--	581 72 48-01	Calcomanía para la desviación
--	532 43 96-81	Forro del apoyo para los pies (LI)

**CÓDIGO PIEZA
No. No.**

CÓDIGO PIEZA No.	No.	DESCRIPCIÓN
--	532 43 96-82	Forro del apoyo para los pies (LD)
--	114 20 19-49	Manual de Operario (Inglés/Español)
--	114 20 20-32	Manual de Operario (Français)
--	114 17 02-49	Manual de Repuestos (Inglés/Español)
--	114 17 03-32	Manual de Repuestos (Français)
--	587 71 00-26	Guía de inicio rápido (Inglés/Español)
--	587 71 01-26	Guía de inicio rápido (Inglés/Francés)

RUEDAS Y NEUMÁTICOS

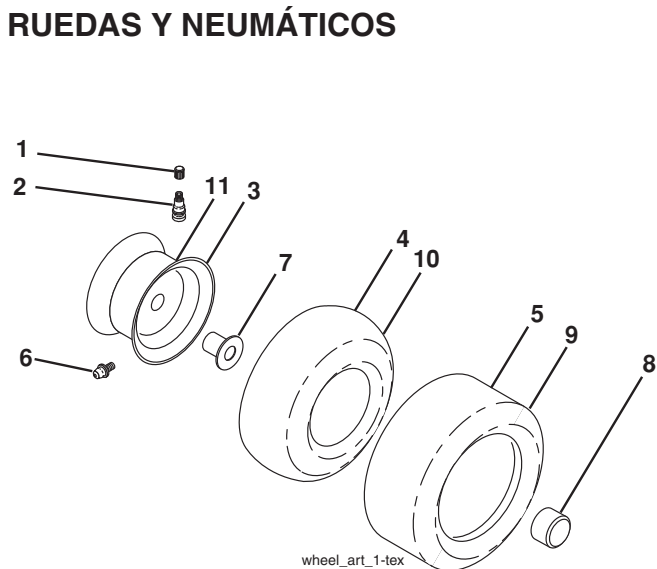

**CÓDIGO PIEZA
No. No.**

CÓDIGO PIEZA No.	No.	DESCRIPCIÓN
1	532 05 91-92	Tapa de la válvula del neumático
2	532 06 51-39	Vástago de la válvula
3	532 13 83-36	Ensamble de las llantas delanteras
4	532 05 99-04	Cámara delantera (Mantenimiento sólo)
5	532 10 62-22	Neumático delantero 15 x 6.0-6
6	532 00 02-78	Accesorio para engrasar (solo para la rueda delantera)
7	532 00 90-40	Rodamiento de la brida (solo para la rueda delantera)
8	532 17 50-39	Tapa del eje 1 50 x 1 00
9	532 12 20-82	Neumático delantero 20 x 10-8
10	532 00 71-52	Cámara trasera (Mantenimiento sólo)
11	532 13 83-37	Ensamble trasero de la llanta 8"
--	532 14 43-34	Sellador para neumáticos (tubo de 10 onzas [283 gr])

NOTA: Las dimensiones de todos los componentes están expresadas en pulgadas americanas. 1 pulgada = 25,4 mm

SERVICE NOTES/AVISO



www.husqvarna.com