

Repair Parts Manual
Manual De Repuestos
TS 248XD/ 96043030900

Please read the operator's manual carefully and make sure you understand the instructions before using the machine.

Por favor lea cuidadosamente y comprenda estas instrucciones antes de usar esta maquina.



English/Spanish

114 19 14-49 Rev. 2



HOW TO USE THIS MANUAL

This manual is designed to provide the customer with a means to identify the parts on his/her tractor when ordering repair parts. The illustrations may or may not represent the actual assemblies; therefore, it is not recommended to use this manual as a guide to assemble or disassemble the tractor. Some hardware and parts are drawn larger in order to more readily identify them.

Each tractor has its own model number. The model number for your tractor can be found on the fender under the seat.

Support / Help

If you require assistance or have questions concerning the application, operation, maintenance or parts for your product:

- Visit our website: www.husqvarna.com
- Call Us Toll Free: 1-800-487-5951

When ordering parts, always give the following information:

- Product - "TRACTOR"
- MODEL NUMBER - "TS 248XD" (96043030900)"
- Part Number
- Part Description

TABLE OF CONTENTS

SCHEMATIC	3
ELECTRICAL.....	4-5
CHASSIS	6-7
DRIVE.....	8-9
ENGINE.....	10-11
STEERING	12-13
MOWER DECK.....	14-15
MOWER LIFT.....	16
SEAT	17
DECALS.....	18

COMO UTILIZAR ESTE MANUAL

Este manual está diseñado para brindarle al comprador un medio para identificar las piezas del tractor para cuando necesite hacer el pedido de un repuesto. Las ilustraciones pueden o no representar los ensambles reales; por lo tanto, no se recomienda utilizar este manual como una guía para ensamblar o desarmar el tractor. Algunos accesorios y piezas están dibujados en tamaños más grandes para identificarlos con mayor facilidad.

Cada tractor tiene su propio número de modelo. El número de modelo del tractor se encuentra en el guardabarros debajo del asiento.

Soporte / Ayuda

Si necesita asistencia o tiene alguna pregunta acerca de la aplicación, operación, mantenimiento o piezas de su producto:

- Visite nuestro sitio web: www.husqvarna.com
- Llámenos de manera gratuita al: 1-800-487-5951

Cuando haga el pedido de una pieza, siempre brinde la siguiente información:

- Producto: "TRACTOR"
- NÚMERO DE MODELO: "TS 248XD" (96043030900)"
- Número de pieza
- Descripción de la pieza

ÍNDICE

DIAGRAMA.....	19
DIAGRAMA ELÉCTRICO.....	20-21
CHASIS	22-23
TRANSMISIÓN	24-25
MOTOR.....	26-27
DIRECCIÓN	28-29
PLATAFORMA DE LA CORTADORA DE CÉSPED.....	30-31
ELEVACIÓN DE LA CORTADORA DE CÉSPED.....	32
ASIENTO.....	33
CALCOMANÍAS.....	34

TRACTOR - MODEL NO. TS 248XD(96043030900), PRODUCT NO. 960 43 03-09 SCHEMATIC

SCH12

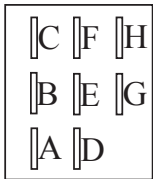
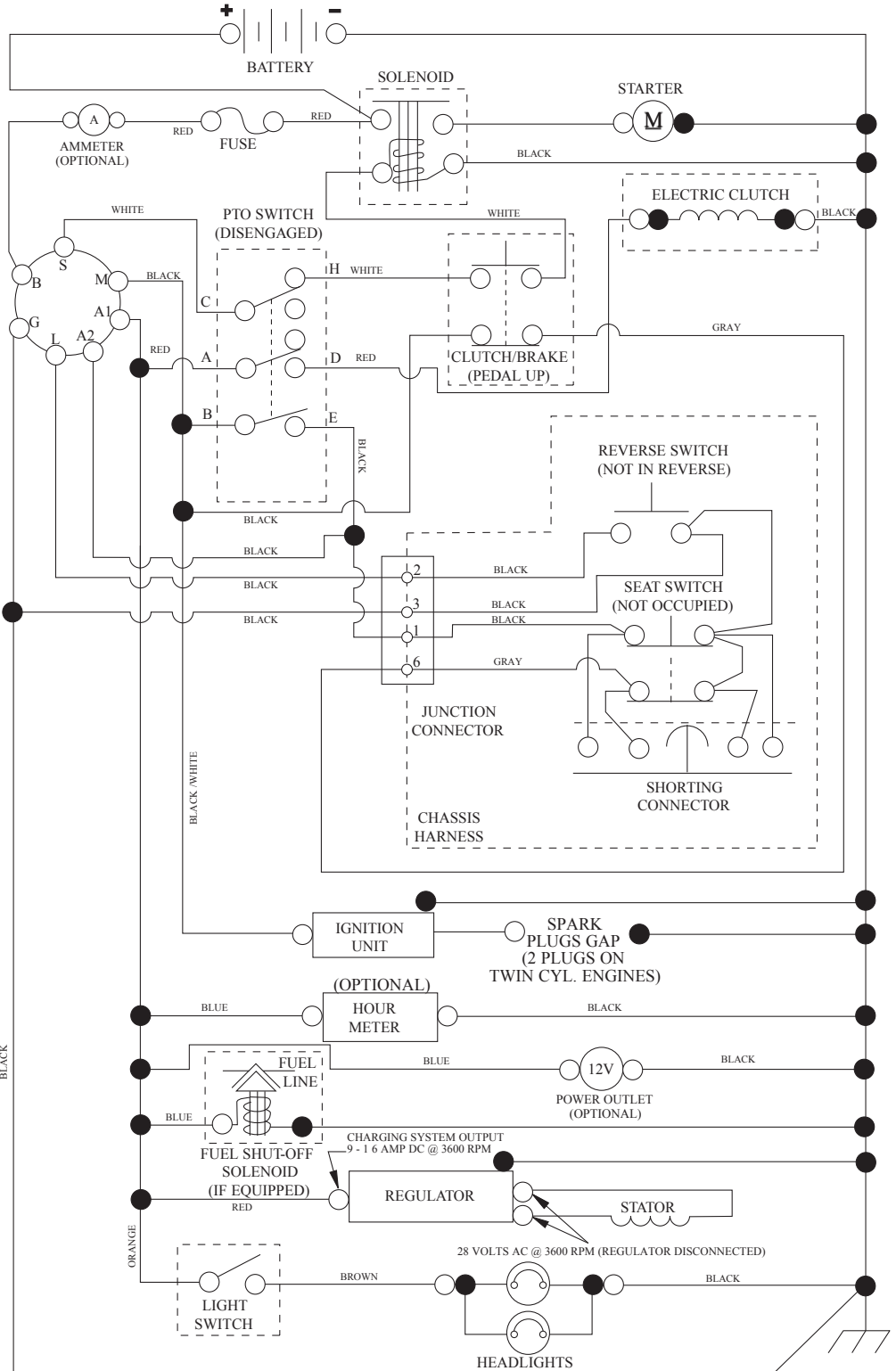

PTO SWITCH (MATING SIDE)

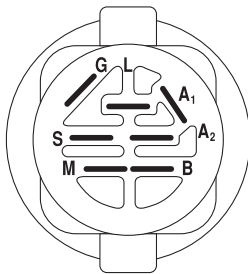

IGNITION SWITCH

POSITION	CIRCUIT	"MAKE"
OFF	M+G+A1	
RUN/OVERRIDE	B+A1	
RUN	B+A1	L+A2
START	B + S + A1	

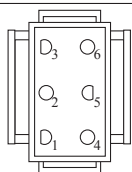

CHASSIS HARNESS CONNECTOR (MATING SIDE)

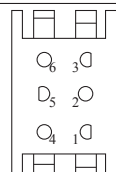

DASH HARNESS CONNECTOR

WIRING INSULATED CLIPS
NOTE: IF WIRING INSULATED CLIPS WERE REMOVED FOR SERVICING OF UNIT, THEY SHOULD BE RE-INSTALLED TO PROPERLY SECURE YOUR WIRING.

● NON-REMOVABLE CONNECTIONS

○ REMOVABLE CONNECTIONS

**TRACTOR - MODEL NO. TS 248XD(96043030900), PRODUCT NO. 960 43 03-09
ELECTRICAL**

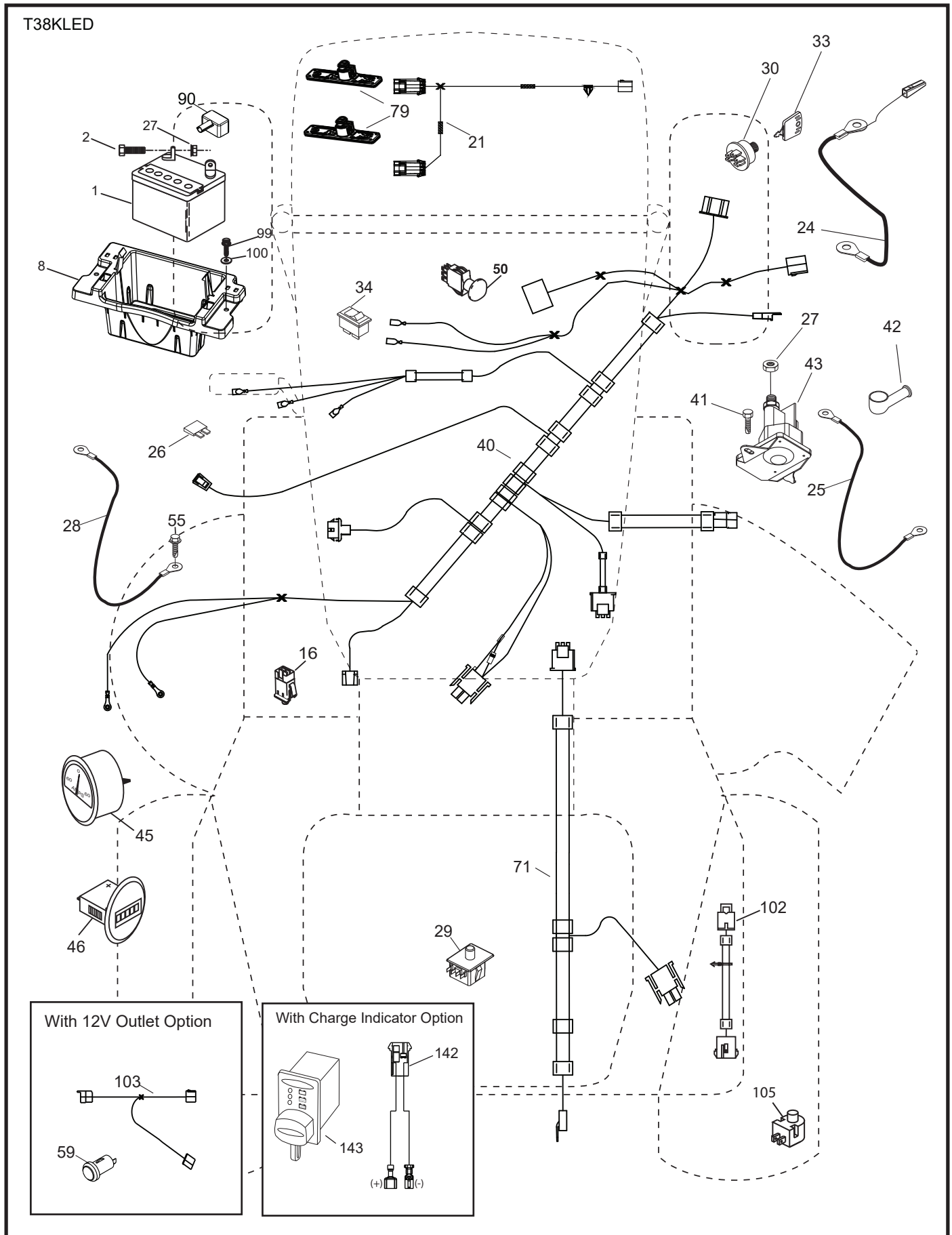

**TRACTOR - MODEL NO. TS 248XD(96043030900), PRODUCT NO. 960 43 03-09
ELECTRICAL**

KEY NO.	PART NO.	DESCRIPTION
1	532 16 34-65	Battery
2	874 76 04-12	Bolt Hex Head 1/4-20 x 3/4
8	587 20 51-01	Box Battery
16	532 17 61-38	Switch Interlock Push-In
21	585 43 64-02	Harness Lights LED
24	585 55 56-01	Cable Battery
25	585 55 55-01	Cable Starter
26	532 17 51-58	Fuse
27	596 13 36-01	Locknut, Keps. 1/4-20
28	532 41 65-88	Cable, Ground
29	532 19 27-49	Switch, Seat
30	532 19 33-50	Switch, Ign
33	532 41 19-35	Key\Chain
34	532 11 07-12	Switch Light / Reset
40	501 13 31-01	Harness Ign. Dash
41	817 72 04-08	Screw Thd Cut 1/4-20 x 1/2
42	532 13 15-63	Cover, Terminal
43	582 04 28-02	Solenoid
45	587 55 39-06	Ammeter Gauge Round
46	587 55 40-06	Hourmeter
50	582 10 76-02	Switch PTO
55	817 06 05-12	Screw Thdrol 5/16-18 x 3/4 TYTT
59	596 94 10-01	Receptacle, 12V. Snap-in, Tex
71	532 19 42-76	Harness Chassis
79	597 52 30-01	Light, Husq GT 3, LED Bar
90	532 43 53-95	Cover Terminal
99	817 67 04-12	Screw Hexwsh Thdrol 1/4-20 x 3/4
100	596 13 53-01	Washer, Plain 9/32 x 7/8 Clr. Zn.
102	532 40 44-54	Harness Pigtail
103	532 42 17-47	Harness 12-Volt Pigtail
105	532 40 75-68	Switch Reverse TT Pedal Control

NOTE: All component dimensions given in U.S. inches
1 inch = 25.4 mm

**TRACTOR - MODEL NO. TS 248XD(96043030900), PRODUCT NO. 960 43 03-09
CHASSIS**

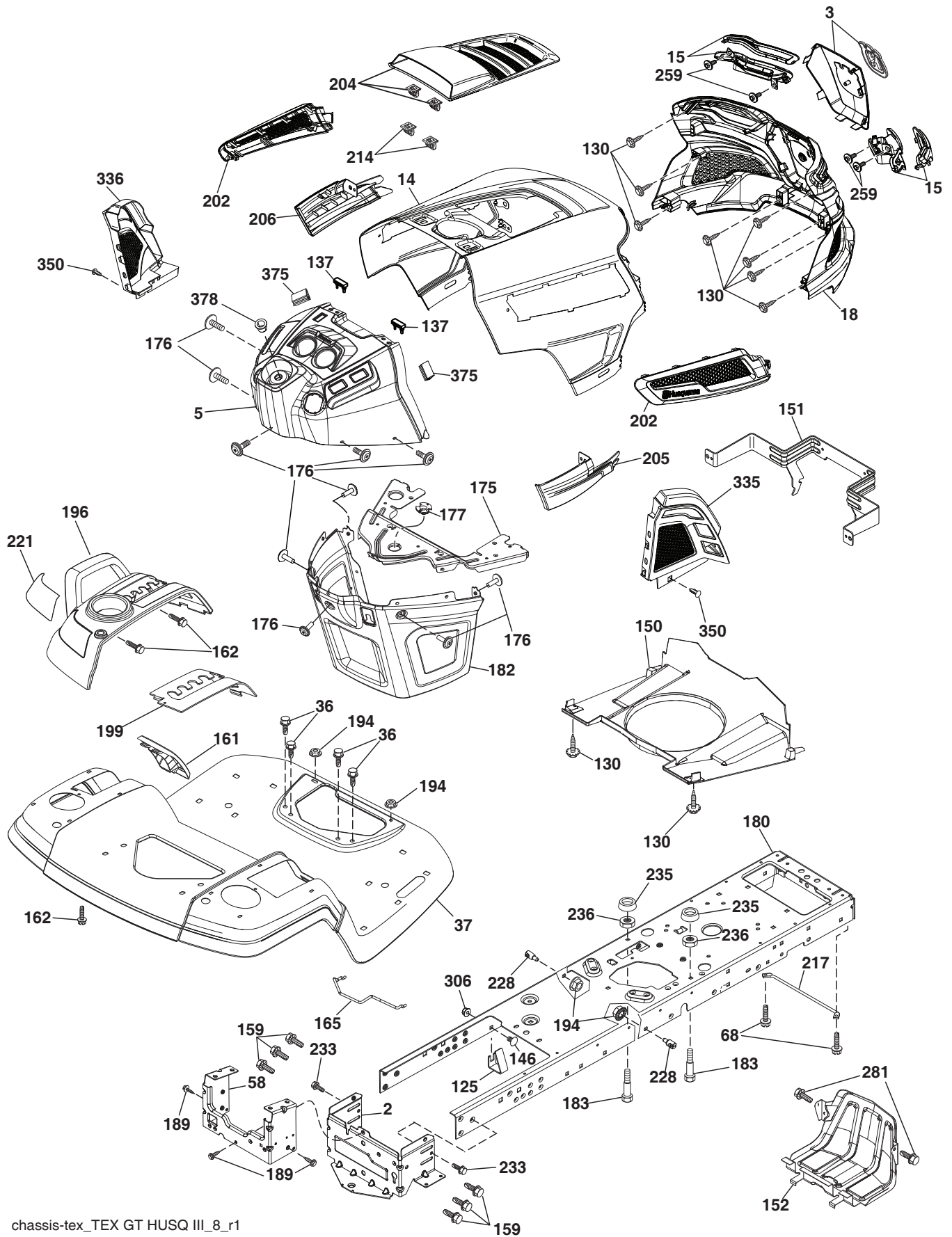

chassis-tex_TEX GT HUSQ III_8_r1

**TRACTOR - MODEL NO. TS 248XD(96043030900), PRODUCT NO. 960 43 03-09
CHASSIS**

KEY NO.	PART NO.	DESCRIPTION	KEY NO.	PART NO.	DESCRIPTION
2	532 41 22-82	Drawbar Lower	194	596 13 57-01	Nutlock, Prvl, Torq. 5/16-18 x .68
3	597 68 82-01	Kit, Grille Applique, (includes applique cover and emblem badge)	196	532 43 97-16	Console Asm. Deck Lift
5	590 74 88-17	Dash	199	532 19 82-59	Plate Deck Lift
14	532 44 11-77	Hood	202	597 86 77-01	Kit, Side Vents, LH/RH (includes LH/RH side vents)
15	597 86 79-01	Kit, SVC, Hus GT3, LED Headlights (includes LH/RH lens and LH/RH housing)	204	597 40 80-01	Kit, Top Vent (includes top vent and clip retainers)
18	597 40 71-02	Grille Asm.	205	532 43 97-30	Trim Hood Side RH
36	817 06 05-12	Screw 5/16-18 x 3/4	206	532 43 97-29	Trim Hood Side LH
37	532 44 12-08	Fender	214	532 19 91-45	Clip Retainer Tinner
58	532 41 22-81	Drawbar Upper	217	532 40 91-67	Rod Pivot
68	596 03 07-01	Screw, Hexagon, 5/16-18 x 1/2	221	532 19 89-09	Reflector LH
125	581 68 48-01	Clip Fuel Line	228	532 19 51-61	Stud Fastner
130	596 32 17-01	Screw, #10 x 0.750	233	532 19 65-39	Bolt, Shoulder
137	532 40 75-90	Bumper Dash	235	596 56 42-01	Spacer, Fender, Clr. Zn
146	581 85 79-01	Bolt	236	873 93 05-00	Nut Lock 5/16-18 unc
150	532 43 97-74	Air Duct	259	596 43 40-01	Screw #10.10 x 0.500, Bos Thread
151	532 43 66-70	Bracket Pivot Hood	281	817 00 06-16	Screw 3/8-16 x 1 Smgml, Tap
152	532 43 98-70	Shield Browning	306	873 90 06-00	Nut Lock
159	817 00 06-12	Screw 3/8-16 x 3/4	335	532 44 82-04	Cover RH Lower Close Out
161	532 43 99-29	Window, Fuel	336	532 44 53-09	Cover LH Lower Close Out
162	596 13 41-01	Screw, Hex. Tap. 1/4-15 x 1/2	350	532 44 51-43	Clip X-mas Tree
165	532 19 43-30	Support Tank Rear	375	586 90 82-01	Dash Clip-On Bumper
175	590 60 77-02	Crossmember	375	586 90 82-01	Dash Clip-On Bumper
176	532 40 07-76	Screw 10-24 x 5/8	378	590 84 98-01	Bushing, Flange
177	532 19 52-28	Bushing Steering	--	532 43 18-82	Kit Guard Brush
180	593 34 63-01	Chassis			
182	532 40 68-59	Dash Lower			
183	595 30 57-01	Screw, Hexagon, 5/16-18 x 1-1/4			
189	817 00 05-12	Screw 5/16-18 x 3/4			

NOTE: All component dimensions given in U.S. inches
1 inch = 25.4 mm

TRACTOR - MODEL NO. TS 248XD(96043030900), PRODUCT NO. 960 43 03-09
DRIVE

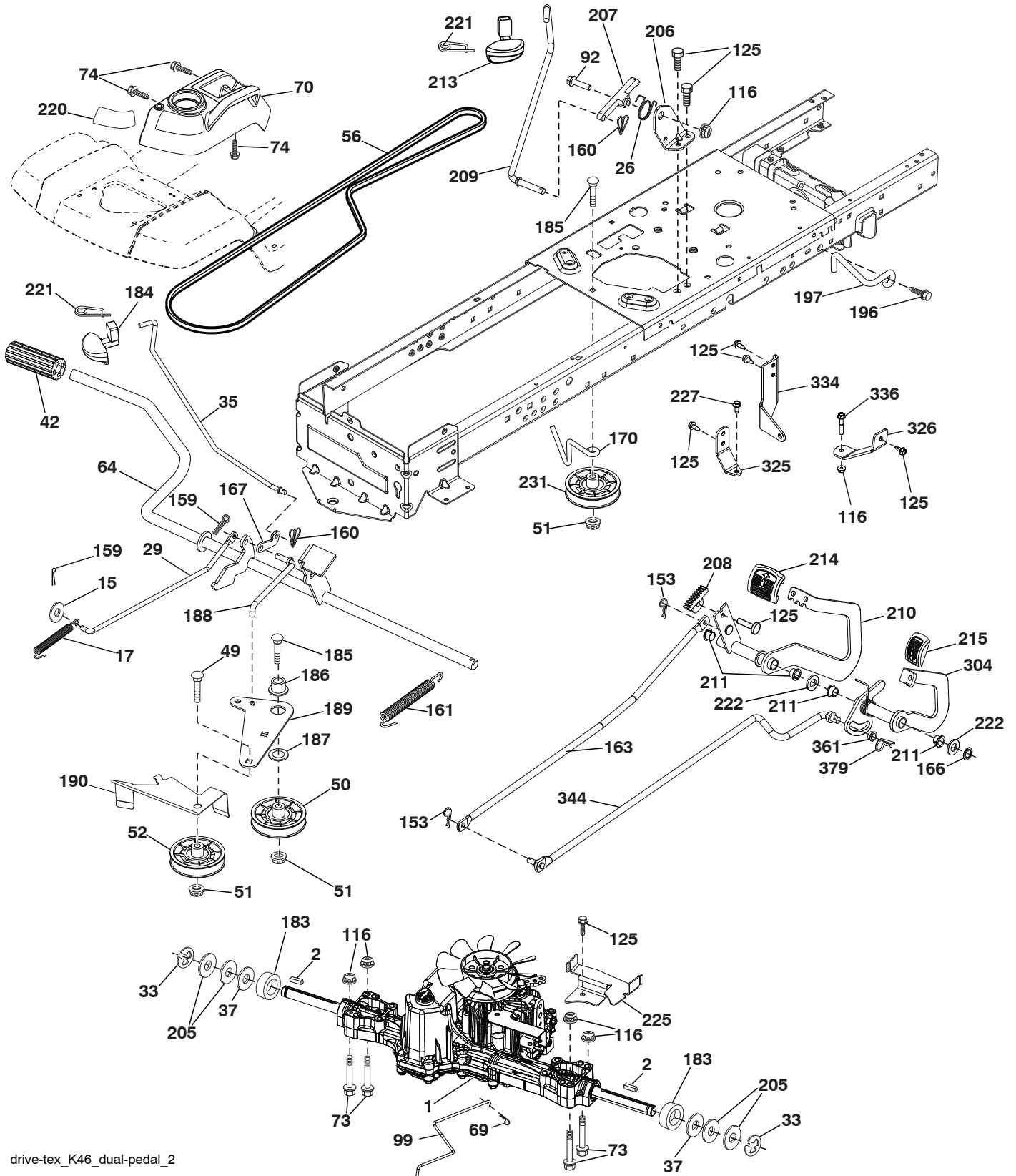

drive-tex_K46_dual-pedal_2

**TRACTOR - MODEL NO. TS 248XD(96043030900), PRODUCT NO. 960 43 03-09
DRIVE**

KEY NO.	PART NO.	DESCRIPTION	KEY NO.	PART NO.	DESCRIPTION
1	---	Transaxle, TUFFTORQ K46CR (501051401) (Order parts from transaxle manufacturer.)	185	872 11 06-22	Bolt Rdhd Sqnk 3/8-16 x 2-3/4 Gr. 5
2	532 12 35-83	Key	186	532 19 43-21	Spacer Retainer
15	819 13 13-16	Washer 13/32 x 13/16 x 16 Ga.	187	596 13 55-01	Washer, 13/32 x 2 Clear, Zinc
17	532 41 36-78	Spring, Brake	188	582 21 70-01	Link Clutch Ground Drive Long
26	532 19 96-79	Spring Return Cruise	189	532 19 43-17	Bellcrank Ground Drive
29	532 40 38-06	Rod, Brake	190	532 19 43-18	Keeper Bellcrank Ground Drive
33	812 00 00-01	Ring E	196	817 00 06-16	Screw 3/8-16 x 1
35	590 60 59-02	Rod, Brake, Park	197	587 40 20-01	Link Clutch Anti-Rotation
37	532 18 89-67	Washer Hardened	205	532 12 17-48	Washer
42	532 00 88-83	Cover, Foot Pedal	206	532 44 85-96	Bracket Mount Latch Cruise
49	596 13 62-01	Bolt, Cup Head, 3/8-16 x 3/4	207	587 03 14-02	Latch Control Cruise
50	532 19 43-27	Pulley Idler Flat	208	596 56 41-01	Gear
51	873 90 06-00	Lock Nut 3/8-16	209	590 52 78-02	Rod Control Cruise
52	532 19 43-26	Idler V-Groove	210	588 98 72-02	Dualped Asm, Forward, Tex
56	592 85 52-01	V-Belt, Drive	211	532 12 01-83	Bearing Nylon
64	532 19 78-65	Shaft Asm. Pedal Brake Control	213	532 40 31-19	Knob Control Cruise
69	532 42 33-03	Hairpin Soft Zink .059 x 1.125	214	532 42 12-63	Pedal Pad, Forward, Tex, Std
70	532 43 96-61	Console Asm	215	596 90 83-01	Pedal Pad, Square, Reverse
73	596 13 65-01	Bolt, Hex. Head, 5/16-18 x 1-1/2	220	532 19 89-08	Reflector RH
74	596 13 41-01	Screw, Hex. Tap 1/4-15 x 1/2	221	532 40 31-87	Retainer Spring Clip Handle
92	595 30 57-01	Screw, Hexagon, 5/16-18 x 1-1/4	222	879 21 20-10	Washer 21/32 x 1-1/4 x 10 Ga.
99	582 40 45-01	Rod Spring Bypass	225	532 40 33-19	Keeper Belt Trans.
116	596 13 57-01	Nutlock, Prvl. Torq. 5/16-18 x .68	227	596 13 59-01	Bolt, Hex. 5/16-18 x 3/4 Clr. Znc.
125	817 00 05-12	Screw 5/16-18 x 3/4	231	532 40 72-87	Idler V-Groove
153	532 00 44-97	Retainer Spring	304	588 98 73-02	Dualped Asm, Reverse, Tex
159	596 02 95-01	Pin, Cotter, 1/8 Dia. x 3/4	325	586 43 12-02	Bracket LH
160	596 02 94-01	Clip, Retainer, "M-Shape"	326	586 00 11-02	Bracket RH
161	532 10 57-09	Spring, Return, Clutch	334	585 88 22-02	Sway Rod Bracket
163	588 56 63-01	Rod, Dualped, Fwd, K46/K57/K58	336	587 25 96-02	Bolt, Hex. 5/16-18 x 1-3/4 Flanged
166	532 42 91-64	Nut Push	344	597 64 72-01	Rod, Dp, Rvs, 48F/54F, K46/K58
167	532 40 52-57	Latch Brake Parking	361	597 13 67-01	Bushing, Dual Ped, Rvs, Slide
170	532 41 34-30	Keeper Belt Centerspan	379	596 58 06-01	Pin, Retaining 1-7/16 x 0.073
183	532 13 70-57	Spacer Split			
184	587 65 37-01	Handle Parking Brake			

NOTE: All component dimensions given in U.S. inches
1 inch = 25.4 mm

**TRACTOR - MODEL NO. TS 248XD(96043030900), PRODUCT NO. 960 43 03-09
ENGINE**

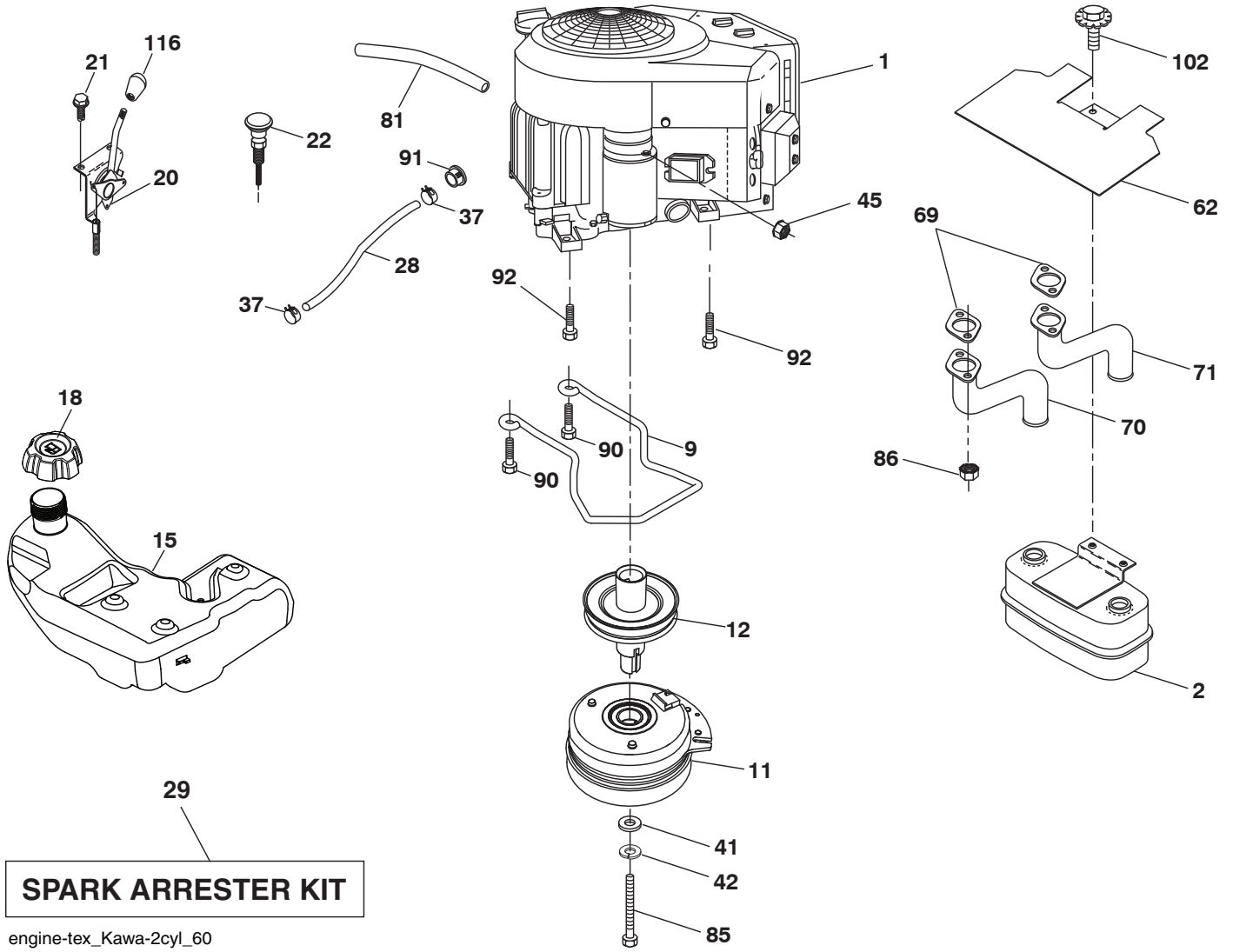

**TRACTOR - MODEL NO. TS 248XD(96043030900), PRODUCT NO. 960 43 03-09
ENGINE**

KEY NO.	PART NO.	DESCRIPTION
1	-----	Engine Kawa No. FR691-DS15 (581557501) (Order parts from engine manufacturer.)
2	589 81 87-01	Muffler
9	501 83 26-02	Keeper Belt Engine
11	587 25 50-01	Clutch Electric
12	586 89 96-01	Pulley Engine
15	532 43 80-29	Tank Fuel
18	585 12 48-01	Cap Asm
20	532 42 43-41	Control Throttle
21	596 32 17-01	Screw, #10 x 0.750 BOS Thread
22	532 18 95-41	Control Choke
28	532 40 11-35	Fuel Line
29	532 13 71-80	Spark Arrester Kit
37	532 12 34-87	Clamp Hose
41	532 12 61-97	Washer 1-1/2 OD x 15/32 ID x .250
42	596 23 89-01	Washer, 7/16 in. Clr. Zn
45	596 13 36-01	Locknut, Keps. 1/4-20
62	532 43 40-17	Heat Shield
69	532 17 81-51	Gasket
70	583 95 56-01	Tube Exhaust LH
71	583 95 57-01	Exhaust Tube RH
81	532 14 84-56	Tube Drain Oil Easy
85	501 60 67-01	Bolt 7/16-20 x 5 Gr. 5
86	532 18 43-62	Nut, Hex, Flange
90	817 00 06-16	Screw 3/8-16 x 1
91	532 18 74-95	Bushing
92	817 12 06-16	Screw 3/8-16 x 1
102	817 00 05-12	Screw 5/16-18 x 3/4
116	539 13 26-24	Knob Soft Touch

NOTE: All component dimensions given in U.S. inches
1 inch = 25.4 mm

For engine service and replacement parts, call the toll free number for your engine manufacturer listed below:

Kawasaki 1-949-460-5688

TRACTOR - MODEL NO. TS 248XD(96043030900), PRODUCT NO. 960 43 03-09
STEERING ASSEMBLY

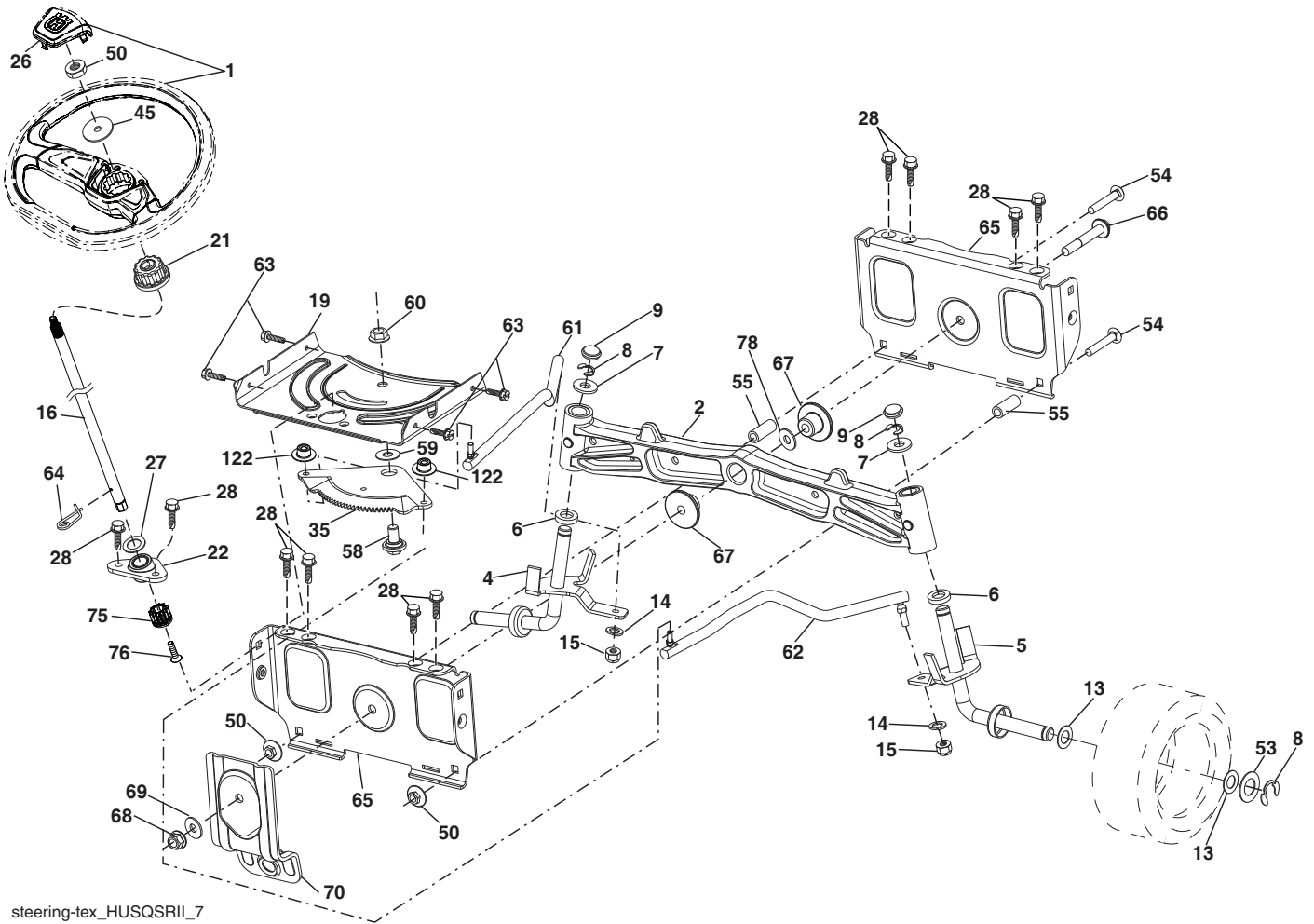

steering-tex_HUSQSR11_7

**TRACTOR - MODEL NO. TS 248XD(96043030900), PRODUCT NO. 960 43 03-09
STEERING ASSEMBLY**

KEY NO.	PART NO.	DESCRIPTION
1	597 86 61-01	Wheel, Steering, Kit (includes steering wheel and cap)
2	532 19 59-68	Axle Asm., Front
4	532 40 30-89	Spindle Asm., LH
5	532 40 30-90	Spindle Asm., RH
6	532 00 62-66	Washer, Thrust .75 x 1.230
7	532 12 17-48	Washer 25/32 x 1-5/8 x 16 Ga.
8	812 00 00-29	Ring, Klip #T5304-75
9	532 12 12-32	Cap, Spindle
13	532 12 17-49	Washer 25/32 x 1-1/4 x 16 Ga.
14	596 23 87-01	Washer, Spring, Lock, .381 ID x .680
15	873 54 06-00	Nut, Crown Lock 3/8-24 unf
16	587 01 60-02	Steering Shaft
19	532 19 47-29	Plate Steering
21	586 84 02-01	Adapter Wheel Steering
22	585 02 98-02	Bearing
26	594 94 91-01	Wheel Steering, Cap
27	596 93 34-01	Washer, Plain
28	817 00 06-12	Screw 3/8-16 x 3/4
35	532 19 47-32	Gear, Sector Plate
45	587 01 64-01	Washer 3/8 ID 2-3/8 OD 12 Ga. PLTD
50	873 90 06-00	Nut Lock Flg 3/8-16 unc
53	532 18 89-67	Washer Hardened .793 x 1.637 x .060
54	874 76 06-36	Bolt Hex 3/8-16 x 2-1/4
55	532 41 47-36	Spacer Axle Brace
58	532 19 47-47	Bolt Shoulder Sector Pivot CFM
59	532 19 47-48	Washer Thrust Sector Steering
60	873 97 10-00	Nut Flange Lock 5/8-11
61	597 07 02-02	Draglink, LH. Adj. Std. Clrzn.
62	597 07 03-02	Draglink, RH. Adj. Std. Clrzn.
63	817 00 05-12	Screw 5/16-18 x 3/4
64	532 19 98-49	Retainer Clip Spring Steering
65	532 19 47-34	Brace Axle Front
66	871 02 07-48	Bolt Hex Fghd 7/16-14 x 3 Serr
67	532 19 47-37	Bushing Front Axle
68	873 90 07-00	Nut Lock Flange 7/16-14 Gr. 5
69	532 19 91-62	Washer 1.5 x .505 x .118
70	585 33 88-01	Bracket Deck Susp. Front
75	580 68 37-01	Pinion
76	580 68 36-01	Screw Head Sock
78	532 05 70-79	Washer Thrust
122	532 44 49-62	Cap Gear Sector

NOTE: All component dimensions given in U.S. inches
1 inch = 25.4 mm

TRACTOR - MODEL NO. TS 248XD(96043030900), PRODUCT NO. 960 43 03-09
MOWER DECK

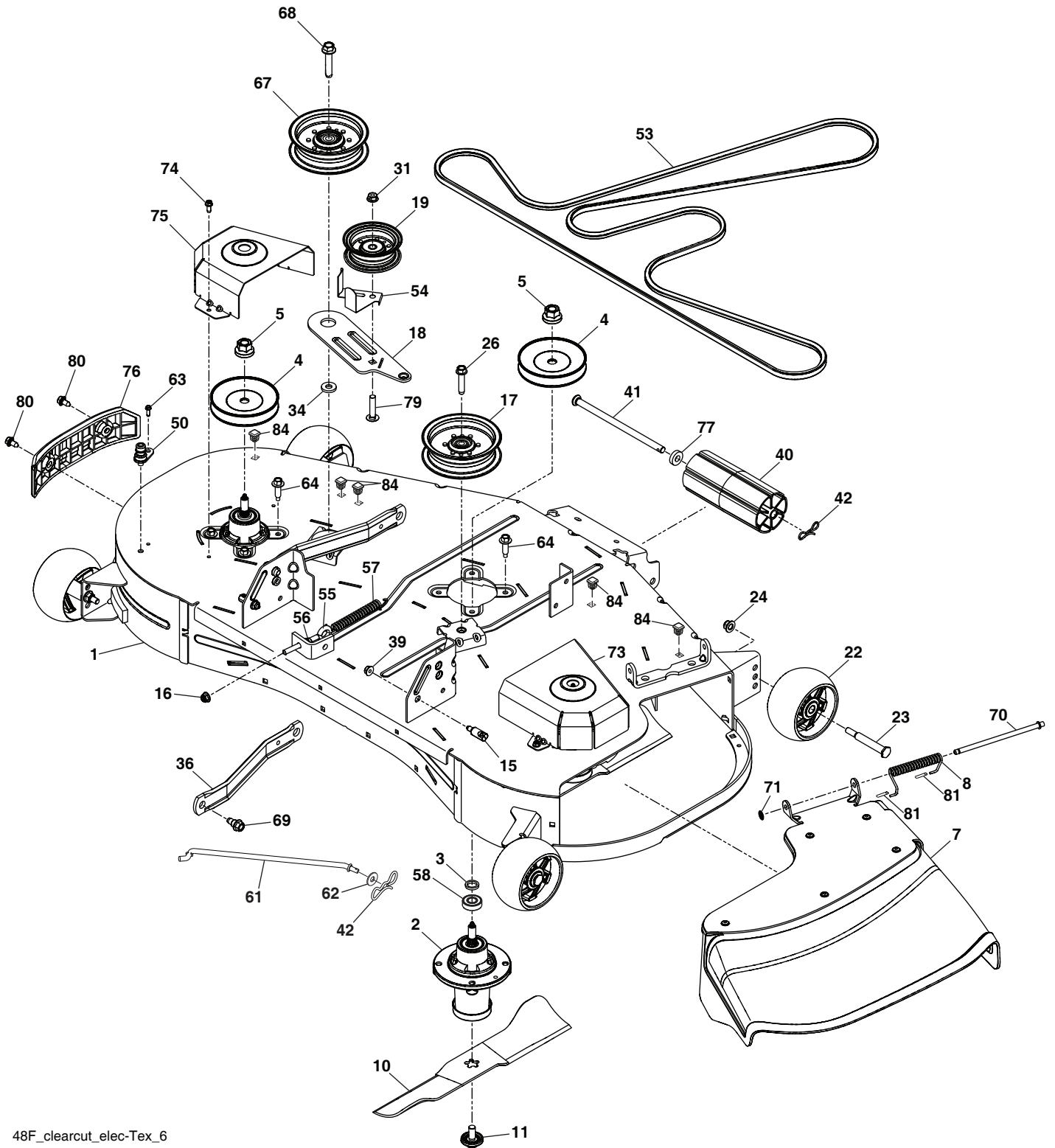

48F_clearcut_elec-Tex_6

**TRACTOR - MODEL NO. TS 248XD(96043030900), PRODUCT NO. 960 43 03-09
MOWER DECK**

KEY NO.	PART NO.	DESCRIPTION	KEY NO.	PART NO.	DESCRIPTION
1	583 81 00-01	Kit, SVC, 48F	55	596 24 08-01	Bolt, Eyelet, 5/16-18 x 3-1/2
2	539 13 18-98	Housing Assembly	56	596 03 92-01	Nut, Lock, Hex. 5/16-18 Clear, Zin.
3	532 18 76-90	Washer-Spacer	57	587 35 84-01	Spring Extn.
4	532 17 34-34	Pulley, Mandrel	58	532 11 04-85	Ball Bearing
5	596 13 48-01	Nut, Hex 9/16-18 x 1.010	61	532 44 32-37	Rod Anti-Sway
7	593 64 97-01	Deflector Asm. 48"	62	596 13 32-01	Washer, 13/32 x 13/16 x 12 Ga.
8	587 35 47-01	Spring - Torsion	63	817 49 04-10	Screw 1/4-20 x 5/8 Hx Self Tap ZD
10	588 81 10-02	Blade	64	584 95 39-01	Bolt Hex Washer Head .313-18 x 1.19
11	532 19 30-03	Bolt Washer Assy 7/16-20	67	532 19 61-06	Pulley Idler
15	532 19 51-61	Stud, Fasten w/ Anti- Rotate	68	596 56 40-03	Bolt, Hex 3/8-16 x 1.78 Clrzinc.
16	594 94 44-01	Nut, Hex. Flng 5/16-18 Nyloc. Clr.	69	532 19 65-39	Bolt Shoulder
17	532 19 61-04	Pulley, Idler Spec. Hub	70	595 29 70-01	Rod, Hinge
18	588 81 22-02	Arm Idler	71	532 11 04-52	Nut Push
19	532 19 31-97	Pulley, Idler	73	588 81 24-02	Cover Mandrel RH
22	589 52 73-01	Wheel, Gauge	74	532 13 77-29	Screw Thdrl 1/4-20 x 5/8
23	596 43 44-04	Bolt, Shoulder 3/8-16 x 3-5/8	75	588 81 31-02	Cover Mandrel LH
24	521 99 65-02	Nut 3/8-16 Hex Flg Nyloc	76	582 54 11-03	Bumper Side Trim
26	588 43 83-01	Screw 7/16-14 x 2.125 Wsh	77	582 36 05-01	Bushing Nose Roller
31	873 90 06-00	Nut Lock Flng 3/8-16 unc	79	596 13 62-01	Bolt, Cup, Head, 3/8-16 x 3/4
34	532 17 85-15	Washer, Flat Hardened	80	532 17 01-65	Bolt 5/16
36	587 14 05-02	Arm, Susp., Rear	81	532 10 53-04	Cap Sleeve
39	596 13 57-01	Nut, Lock, Prvl. Torq. 5/16-18 x .68	84	596 95 22-01	Plug Hole, Square
40	532 17 60-66	Roller, Nose, 48"	--	532 41 64-05	Connect Quick Coupling
41	594 09 25-01	Rod, Roller, Narrow, Nose, V2			
42	532 19 42-08	Pin Cotter			
50	532 41 55-98	Washout Port			
53	588 81 43-01	Belt, Deck			
54	532 14 10-43	Guard, Belt			

NOTE: All component dimensions given in U.S. inches
1 inch = 25.4 mm

**TRACTOR - MODEL NO. TS 248XD(96043030900), PRODUCT NO. 960 43 03-09
MOWER LIFT**

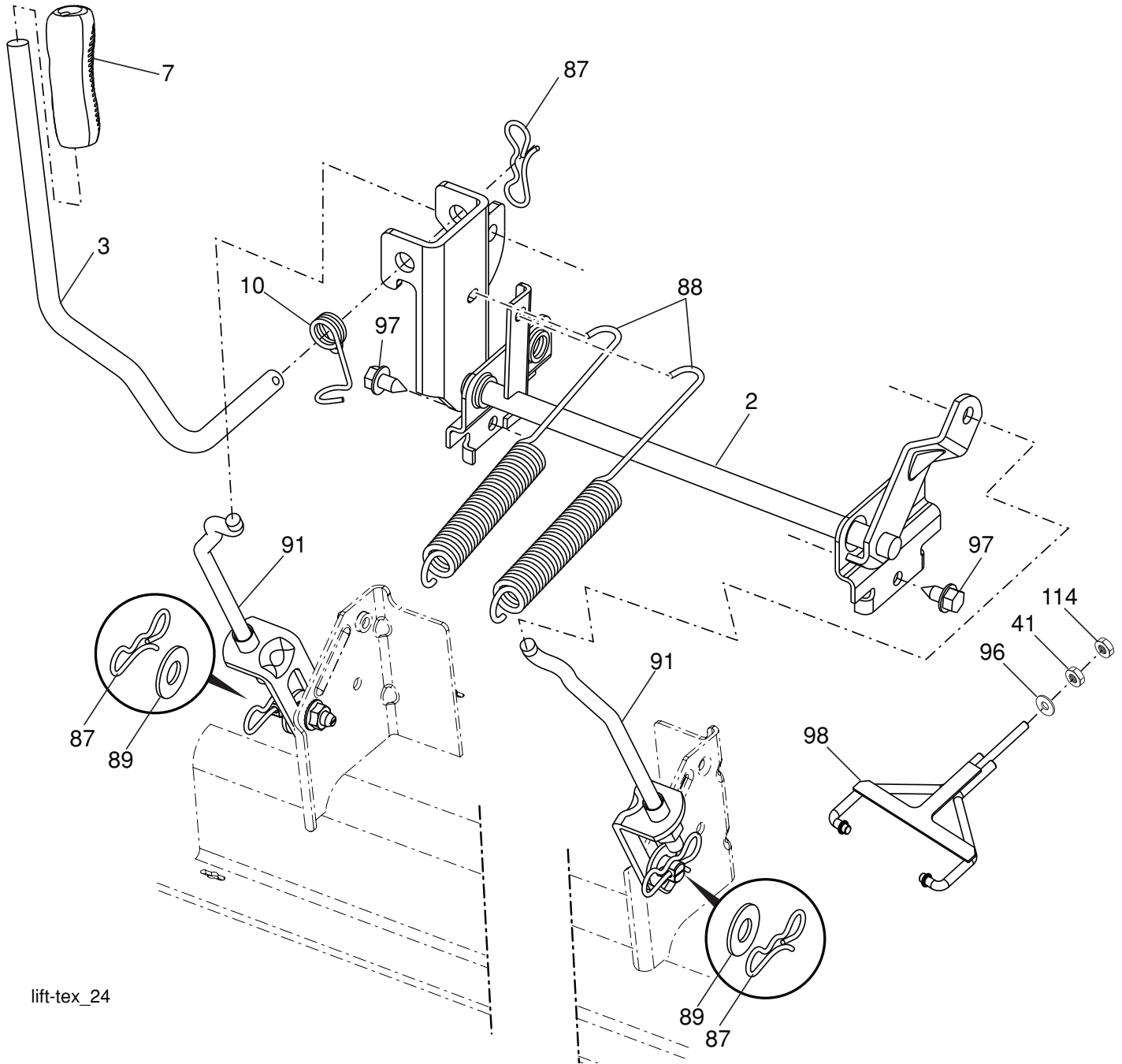

lift-tex_24

KEY NO.	PART NO.	DESCRIPTION
2	532 42 20-27	Shaft Asm., Lift
3	596 27 06-01	Lever, Lift, Handle, Clear, Zinc
7	580 96 23-01	Grip, Lever
10	532 19 63-14	Spring Torsion
41	589 46 49-02	Nut, Lift, Link, Clr. Zn.
87	532 19 42-09	Pin Cotter 7/16 Bow Tie Lock
88	532 41 07-10	Spring Lift Assist
89	819 19 19-12	Washer Clear Zinc

KEY NO.	PART NO.	DESCRIPTION
91	589 46 48-05	Link, Assy. Lift, Rear 10.540
96	593 84 21-01	Bushing
97	817 00 06-12	Screw 3/8-16 x 3/4
98	574 82 25-01	Link Asm. Susp. Front Mower
114	873 36 07-00	Nut Jam 7/16-20

NOTE: All component dimensions given in U.S. inches
1 inch = 25.4 mm

TRACTOR - MODEL NO. TS 248XD(96043030900), PRODUCT NO. 960 43 03-09 SEAT ASSEMBLY

***OPTIONAL**

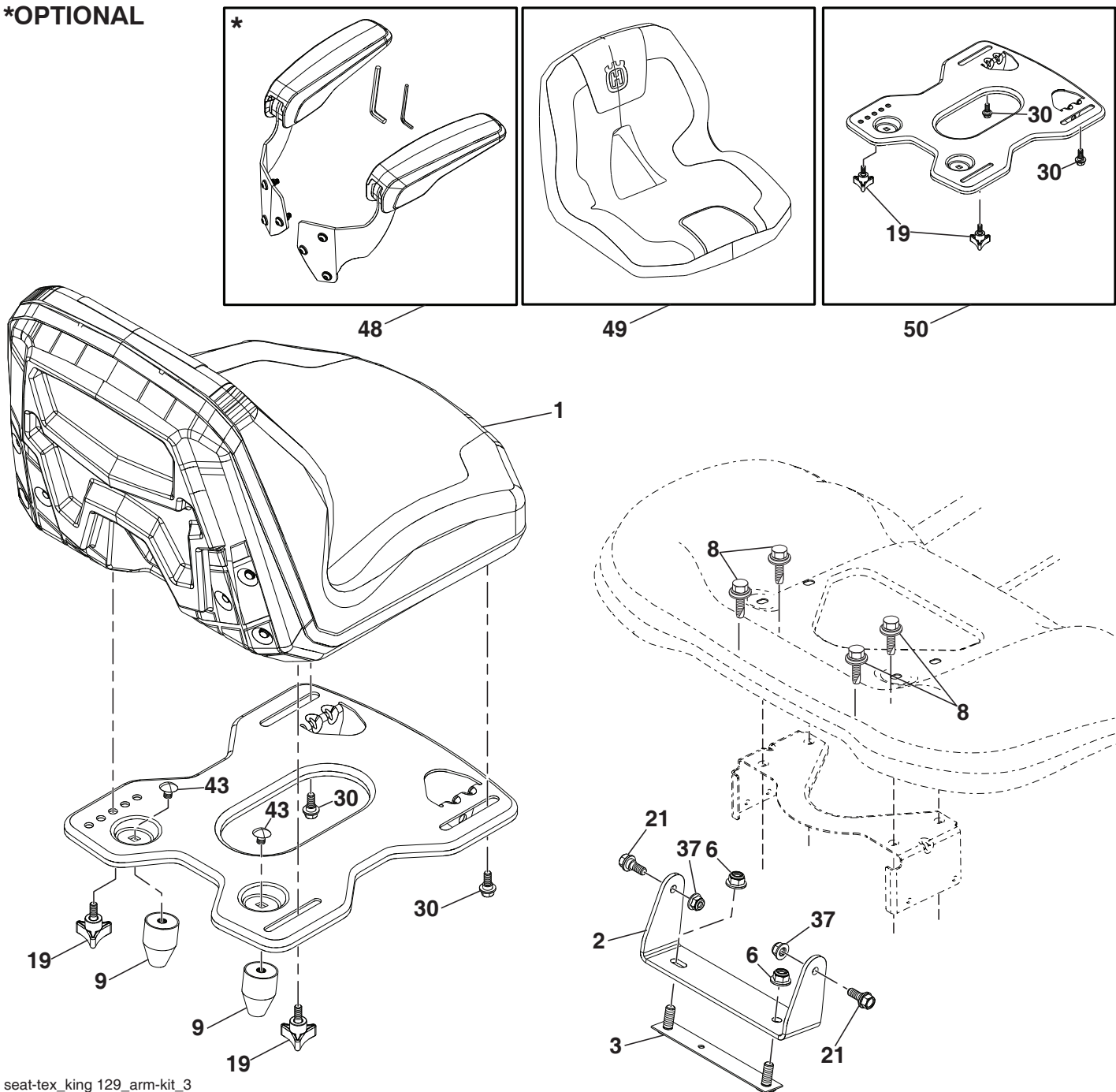

seat-tex_king 129_arm-kit_3

KEY NO.	PART NO.	DESCRIPTION
1	597 65 81-01	Seat, SK150/129 w/o Armrests (includes seat cover key# 49)
2	597 32 99-02	Bracket, PNT, PVT, FNDR, Seat EDIP
3	590 77 76-02	Bracket Asm, Reinfor FNDR, EDIP
6	521 99 65-02	Nut, Hex, Lock w/Flange 3/8-16
8	532 17 18-77	Bolt 5/16-18 unc x 3/4 w/Sems
9	597 78 51-01	Bumper, Rubber, Isolator
19	597 78 31-01	Knob, 3 Wing 5/16-18, CLR, ZN
21	596 24 07-01	Bolt, Hex 5/16-18 x 21/32

KEY NO.	PART NO.	DESCRIPTION
30	597 78-18-01	Bolt, Hex, Should 5/16-18 unc ZPB
37	594 94 44-01	Nut, Hexagon, Flange 5/16-18
43	597 86 93-01	Bolt, Carri, Cqur 3/8 x .45, CLR, ZN
48	597 65 82-03	Service Kit, 15", Seat Arm
49	597 95 94-01	Cover, Husq. 15", (SK129) Seat Service, Kit
50	598 00 16-01	Seat Pan (includes all components illustrated in box for Key# 50)

NOTE: All component dimensions given in U.S. inches
1 inch = 25.4 mm

**TRACTOR - MODEL NO. TS 248XD(96043030900), PRODUCT NO. 960 43 03-09
DECALS**

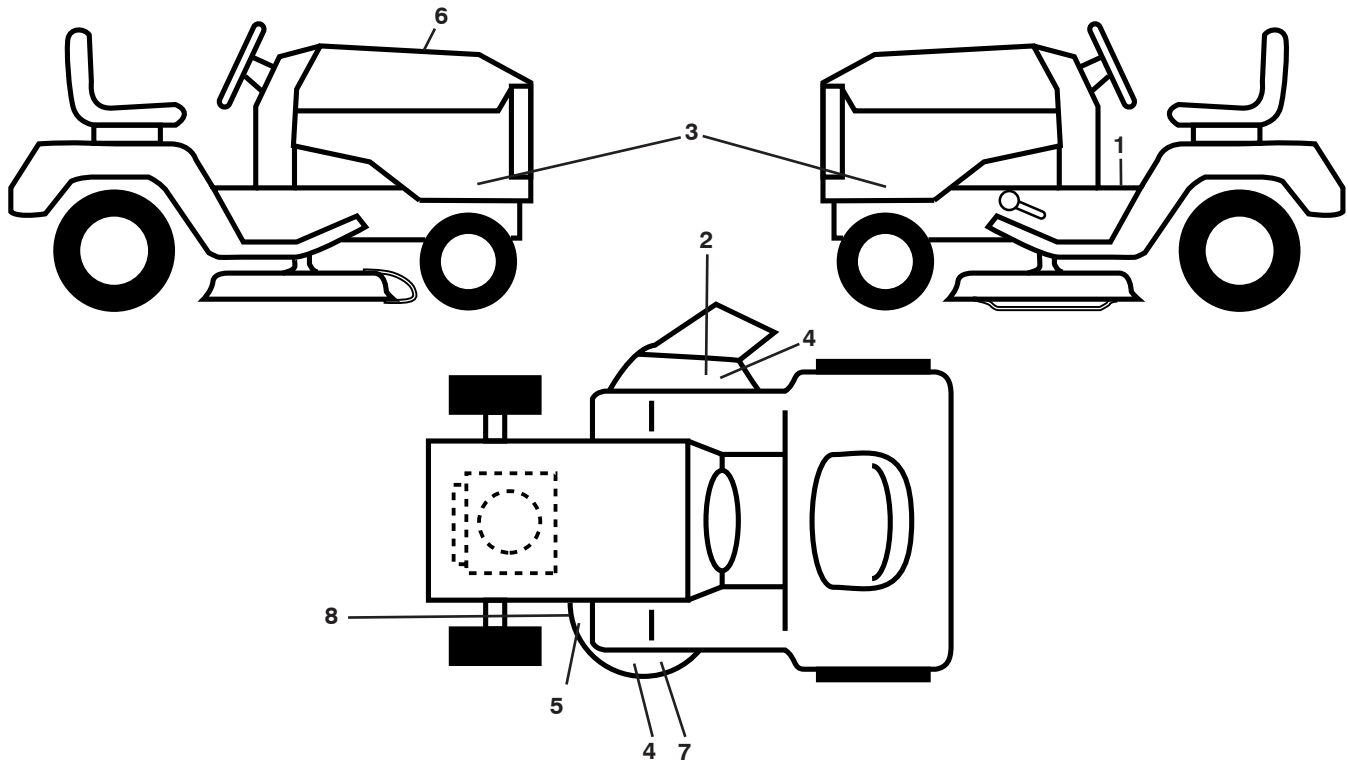

KEY NO.	PART NO.	DESCRIPTION
1	581 57 90-01	Decal, Warning
2	586 97 88-01	Decal, Deflect. Warning
3	598 01 05-01	Decal, Panel SD
4	589 35 79-01	Decal, No Step
5	585 91 01-01	Decal, Warranty
6	589 41 37-01	Decal, Replacement
7	590 88 50-01	Decal, Clearcut Deck
8	581 58 00-02	Decal, Mower Sch
--	501 74 90-01	Decal, Drawbar Locking Differential
--	581 72 48-01	Decal, Bypass

KEY NO.	PART NO.	DESCRIPTION
--	532 43 98-82	Pad, Footrest, LH
--	532 44 15-42	Pad, Footrest, RH
--	114 19 33-49	Manual Operator's (English/Spanish)
--	114 19 34-32	Manual Operator's (French)
--	114 19 14-49	Manual IPL (English/Spanish)
--	587 71 00-26	Quick Start Guide (English/Spanish)
--	587 71 01-26	Quick Start Guide (English/French)

WHEELS AND TIRES

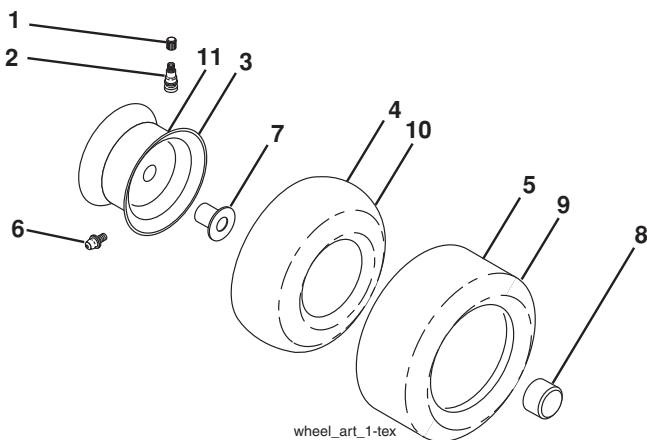

KEY NO.	PART NO.	DESCRIPTION
1	532 05 91-92	Cap Valve Tire
2	532 06 51-39	Stem Valve
3	532 18 18-39	Rim Front Service
4	532 00 81-34	Tube Front (Service Item Only)
5	532 16 10-24	Tire Front 16 x 6.5-8
6	532 00 02-78	Fitting Grease (Front Wheel Only)
7	532 00 90-40	Bearing Flange (Front Wheel Only)
8	532 17 50-39	Cap Axle Blk
9	532 17 04-56	Tire Rear 20 x 10-8
10	532 00 71-52	Tube Rear (Service Item Only)
11	532 13 83-37	Rim Asm 8" rear Service
--	532 14 43-34	Sealant, Tire (10 oz. Tube)

NOTE: All component dimensions given in U.S. inches
1 inch = 25.4 mm

TRACTOR MODELO NO. TS 248XD(96043030900), PRODUCTO NO. 960 43 03-09

DIAGRAMA

SCH12-s

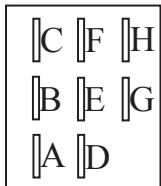
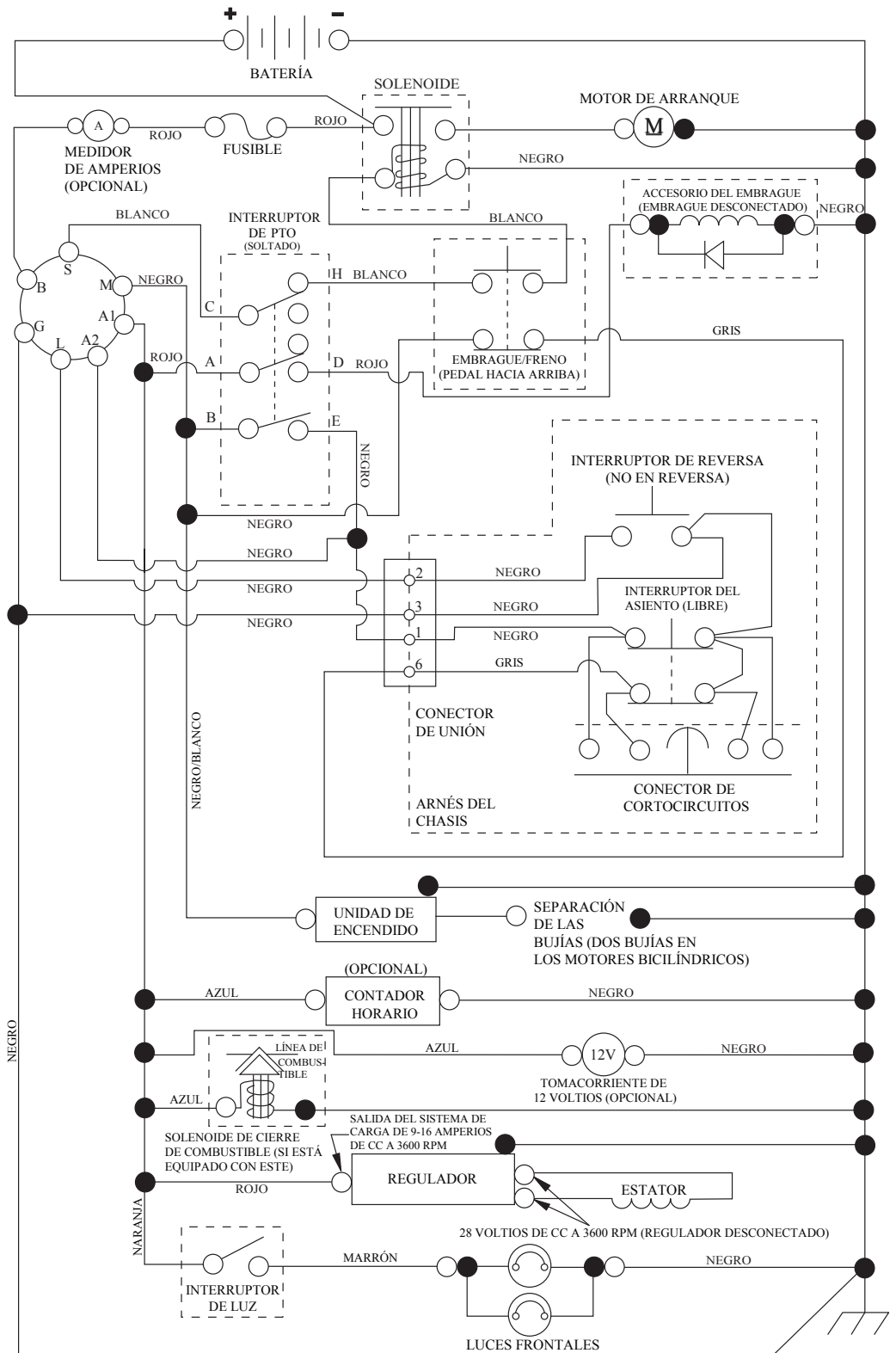

INTERRUPTOR DE PTO (CARA DE ACOPLAMIENTO)

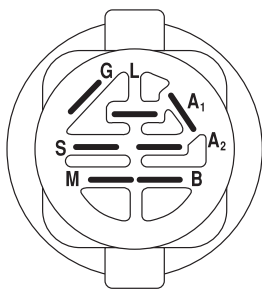

INTERRUPTOR DE ENCENDIDO

POSICIÓN	CIRCUITO «MARCA»
APAGADO	M+G+A1
PONER EN FUNCIONAMIENTO/ANULAR	B+A1
PONER EN FUNCIONAMIENTO	B+A1 L+A2
ARRANCAR	B + S + A1

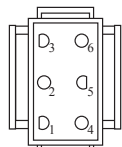

CONEXIÓN DEL ARNÉS DEL CHASIS (LATERAL QUE COINCIDA)

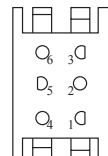

CONEXIÓN PARA EL ARNÉS DEL TABLERO

NOTA SOBRE LAS ABRAZADERAS DE AISLAMIENTO DEL CABLEADO: SI SE QUITAN LAS ABRAZADERAS DE AISLAMIENTO DEL CABLEADO PARA HACER EL MANTENIMIENTO DE LA UNIDAD, SE LAS DEBERÁ INSTALAR NUEVAMENTE PARA PROTEGER EL CABLEADO ADECUADAMENTE.

● CONEXIONES NO DESMONTABLES

○ CONEXIONES DESMONTABLES

**TRACTOR MODELO NO. TS 248XD(96043030900), PRODUCTO NO. 960 43 03-09
DIAGRAMA ELÉCTRICO**

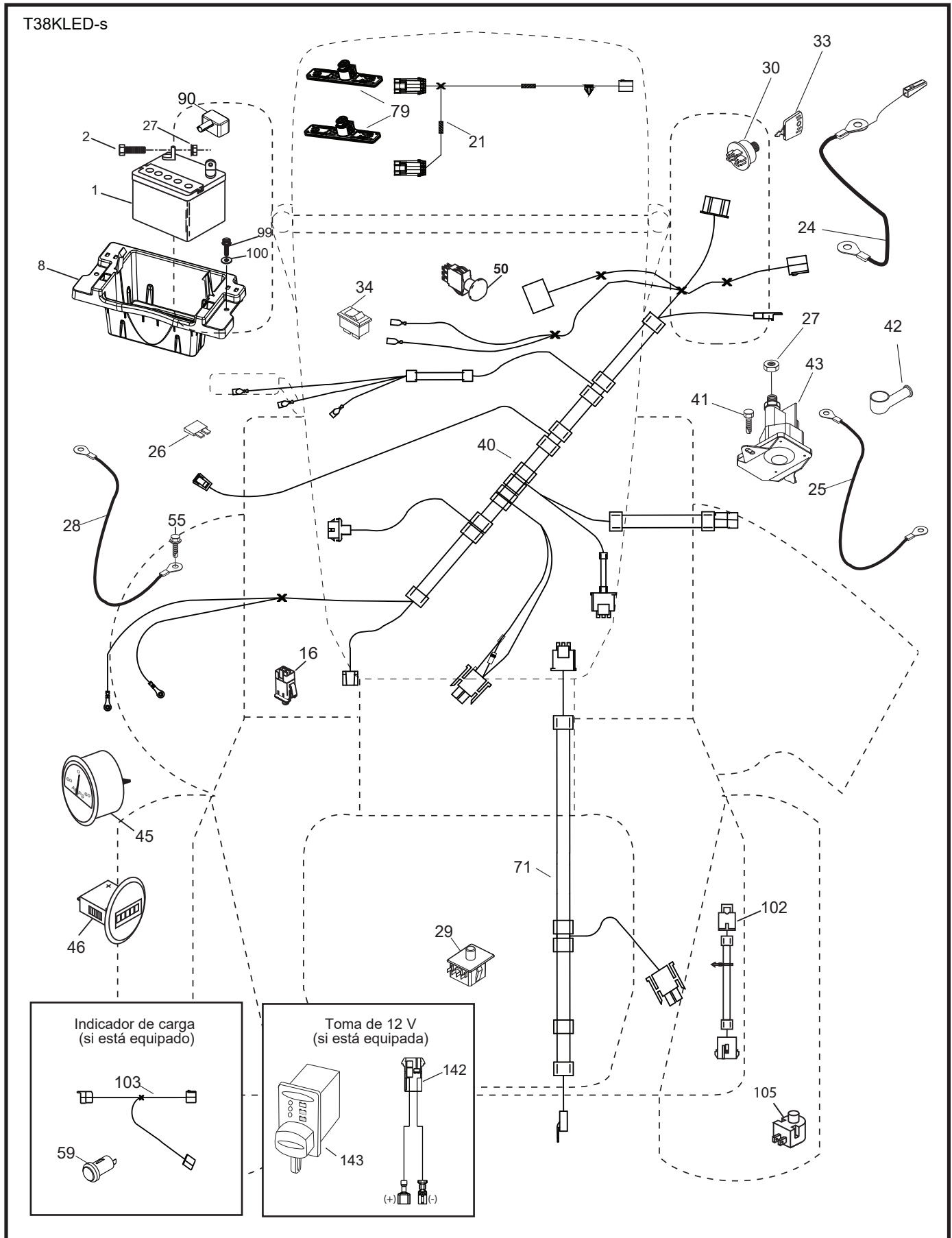

**TRACTOR MODELO NO. TS 248XD(96043030900), PRODUCTO NO. 960 43 03-09
DIAGRAMA ELÉCTRICO**

CÓDIGO No.	PIEZA No.	DESCRIPCIÓN
1	532 16 34-65	Batería
2	874 76 04-12	Perno de cabeza hexagonal de 1/4-20 x 3/4
8	587 20 51-01	Caja de la batería
16	532 17 61-38	Interruptor corta corriente a presión
21	585 43 64-02	Luz del arnés LED
24	585 55 56-01	Cable
25	585 55 55-01	Cable
26	532 17 51-58	Fusible
27	596 13 36-01	Tuerca de presión de 1/4-20
28	532 41 65-88	Cable a tierra
29	532 19 27-49	Interruptor del asiento
30	532 19 33-50	Interruptor de encendido
33	532 41 19-35	Llave/cadena
34	532 11 07-12	Interruptor de luz/de restauración
40	501 13 31-01	Cableado de encendido
41	817 72 04-08	Tornillo
42	532 13 15-63	Cubierta de la terminal
43	582 04 28-02	Solenoide
45	587 55 39-06	Indicador SRVCMNDR
46	587 55 40-06	Indicador HRMTR
50	582 10 76-02	Interruptor
55	817 06 05-12	Tornillo de 5/16-18 x 3/4
59	596 94 10-01	Toma de 12V
71	532 19 42-76	Cableado de encendido, chasis
79	597 52 30-01	Barra de luz LED
90	532 43 53-95	Tapa de los bornes de la batería
99	817 67 04-12	Tornillo 1/4-20 x 3/4
100	596 13 53-01	Arandela de 9/32 x 7/8
103	532 42 17-47	Cable 12V
105	532 40 75-68	Interruptor de control del pedal

NOTA: Las dimensiones de todos los componentes están expresadas en pulgadas americanas. 1 pulgada = 25,4 mm

TRACTOR MODELO NO. TS 248XD(96043030900), PRODUCTO NO. 960 43 03-09
CHASIS

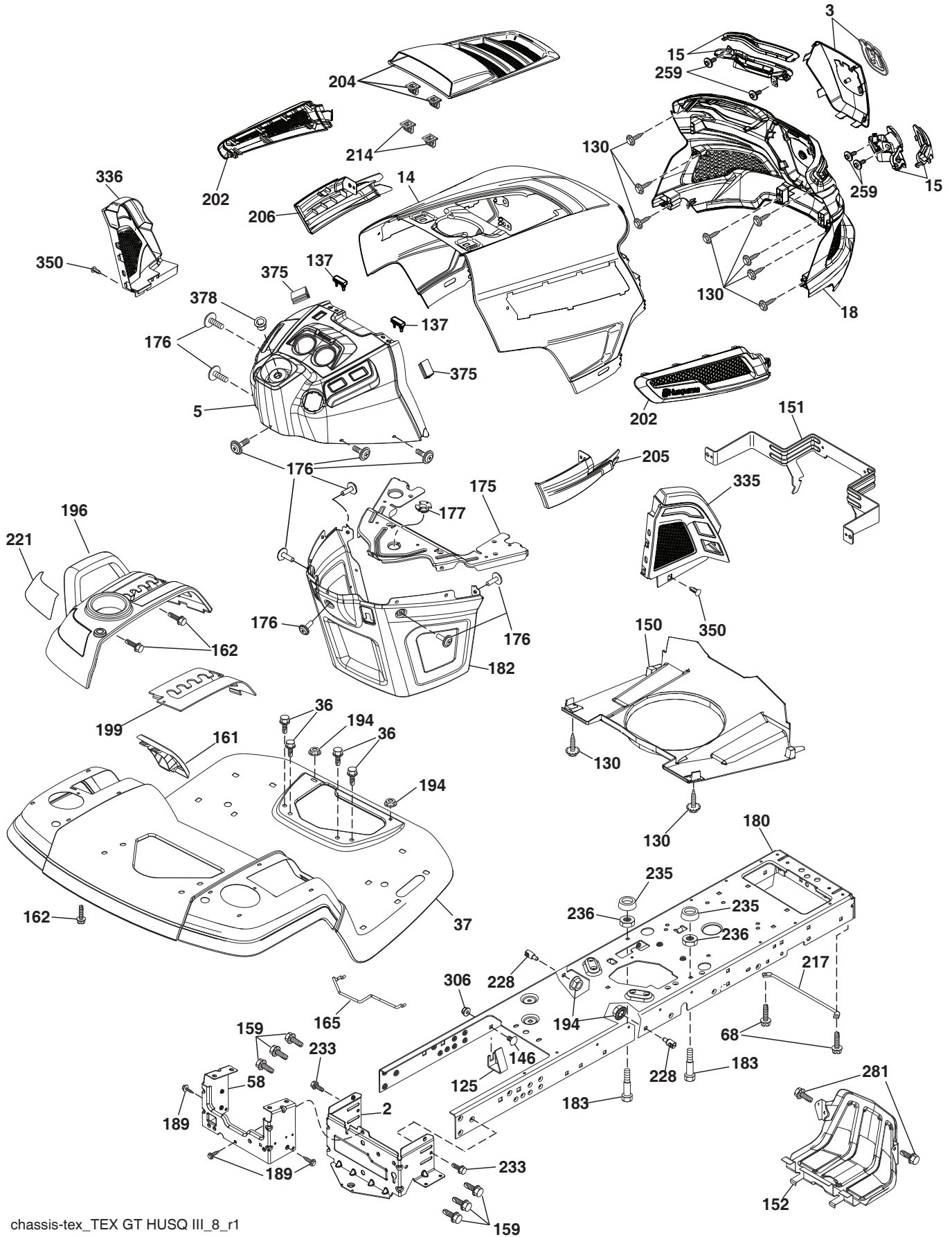

chassis-tex_TEX GT HUSQ III_8_r1

TRACTOR MODELO NO. TS 248XD(96043030900), PRODUCTO NO. 960 43 03-09 CHASIS

CÓDIGO No.	PIEZA No.	DESCRIPCIÓN	CÓDIGO No.	PIEZA No.	DESCRIPCIÓN
2	532 41 22-82	Barra de tracción inferior	194	596 13 57-01	Tuerca de presión de 5/16-18 x .68
3	597 68 82-01	Kit de logotipo (Incluye aplique y emblema.)	196	532 43 97-16	Ensamble de la consola de la plataforma de elevación
5	590 74 88-17	Tablero	199	532 19 82-59	Chapa
14	532 44 11-77	Capota	202	597 86 77-01	Kit, ventilación lateral, LI y LD (incluye ventilaciones laterales LH / LD)
15	597 86 79-01	Kit HUS GT3 faro LED (incluye lente LI/LD y carcasa LI/LD)	204	597 40 80-01	Kit, ventilación parte superior, LI y LD (incluye ventilaciones laterales LH / LD)
18	597 40 71-02	Parrilla ensacamiento	205	532 43 97-30	Camisa de Capota (LD)
25	585 42 02-01	Lente derecho de la parrilla	206	532 43 97-29	Camisa de Capota (LI)
36	817 06 05-12	Tornillo de 5/16-18 x 3/4	214	532 19 91-45	Cierre
37	532 44 12-08	Guardabarros	217	532 40 91-67	Varilla giratoria
58	532 41 22-81	Barra de tracción superior	221	532 19 89-09	Reflector (LI)
68	596 03 07-01	Tornillo de 5/16-18 x 1/2	228	532 19 51-61	Sujetador del travesaño
125	581 68 48-01	Cierre	233	532 19 65-39	Perno
130	596 32 17-01	Tornillo #10 x .075	235	596 56 42-01	Separador del guardabarros
137	532 40 75-90	Cubierta Tablero	236	873 93 05-00	Tuerca de presión 5/16-18 unc
146	581 85 79-01	Perno	259	596 43 40-01	Tornillo n.º 10 x 0,750 rosca BOS
150	532 43 97-74	Cubierta	281	817 00 06-16	Tornillo 3/8-16 x 1 Smgml, Tap
151	532 43 66-70	Soporte de Capota	306	873 90 06-00	Tuerca
152	532 43 98-70	Protector contra oscurecimiento	335	532 44 82-04	Cubierta (LD)
159	817 00 06-12	Tornillo 3/8-16 x 3/4	336	532 44 53-09	Cubierta (LI)
161	532 43 99-29	Ventaniilla de combustible	350	532 44 51-43	Cierre del árbol de navidad
162	596 13 41-01	Tornillo de 1/4-15 x 1/2	375	586 90 82-01	Cubierta Capota
165	532 19 43-30	Soporte de Tanque de Gasolina	378	590 84 98-01	Buje de con brida
175	590 60 77-02	Travesaño	--	532 43 18-82	Protector del cepillo
176	532 40 07-76	Tornillo de 10-24 x 5/8			
177	532 19 52-28	Buje de dirección			
180	593 34 63-01	Chasis			
182	532 40 68-59	Tablero inferior			
183	595 30 57-01	Tornillo de 5/16-18 x 1-1/4			
189	817 00 05-12	Tornillo			
191	586 18 28-01	Parte movable reflexivo (LD)			

NOTA: Las dimensiones de todos los componentes están expresadas en pulgadas americanas. 1 pulgada = 25,4 mm

**TRACTOR MODELO NO. TS 248XD(96043030900), PRODUCTO NO. 960 43 03-09
TRANSMISIÓN**

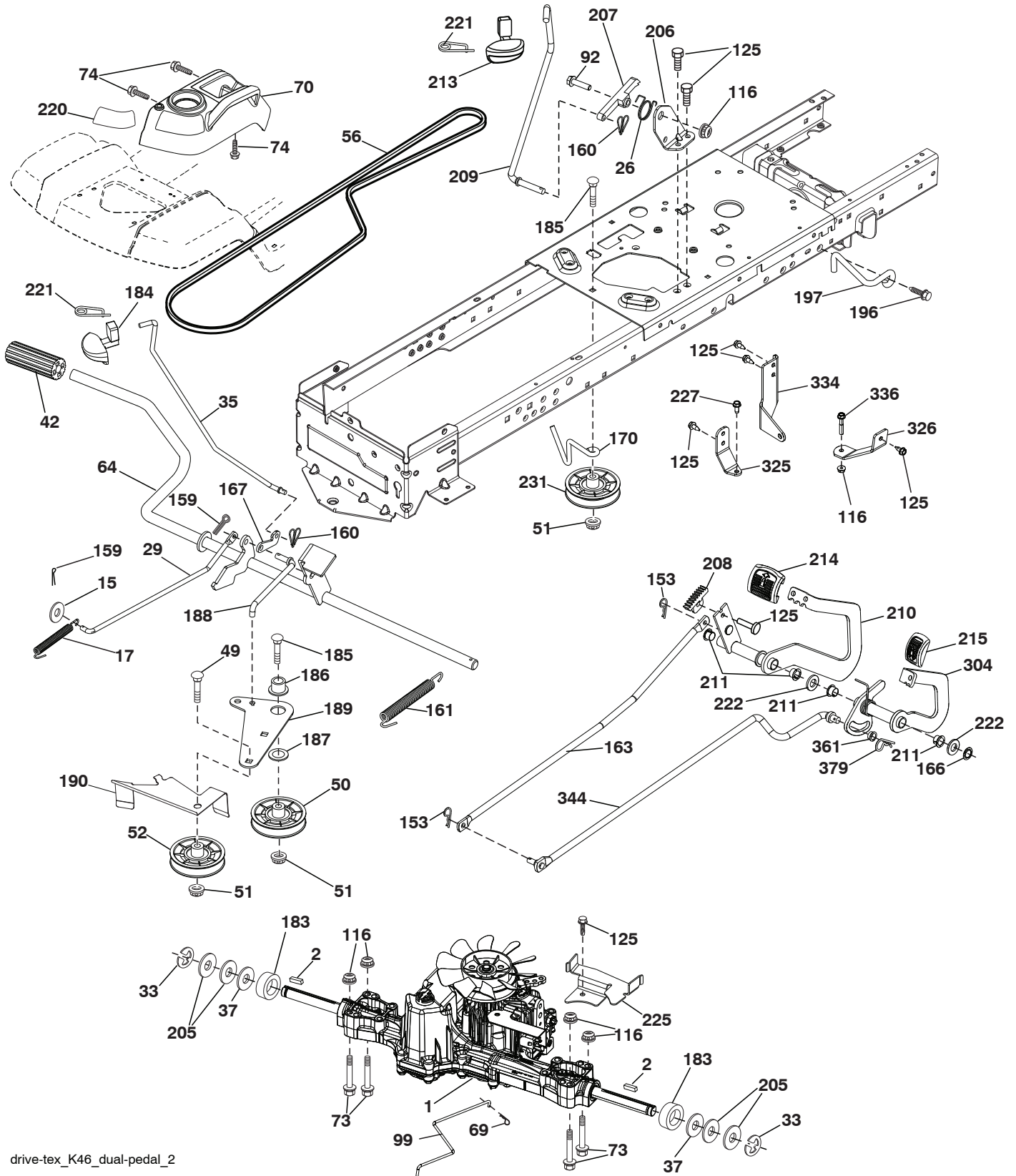

drive-tex_K46_dual-pedal_2

**TRACTOR MODELO NO. TS 248XD(96043030900), PRODUCTO NO. 960 43 03-09
TRANSMISIÓN**

CÓDIGO No.	PIEZA No.	DESCRIPCIÓN	CÓDIGO No.	PIEZA No.	DESCRIPCIÓN
1	---	Transeje, TUFFTORQ K46CR (501051401) (Haga el pedido de las piezas al fabricante del transeje.)	189	532 19 43-17	Palanca acodada del mecanismo de desplazamiento
			190	532 19 43-18	Sujetador de la palanca acodada del mecanismo de desplazamiento
2	532 12 35-83	Llave			
15	819 13 13-16	Arandela 13/32 x 13/16 x calibre 16	196	817 00 06-16	Tornillo 3/8-16 x 1
17	532 41 36-78	Resorte de freno	197	587 40 20-01	Mecanismo de desplazamiento de la mando del embrague
26	532 19 96-79	Crucero con retorno de muelle			
29	532 40 38-06	Varilla del freno	210	588 98 72-01	Montaje de pedal doble, adelante, Tex
33	812 00 00-01	Aro "E"	205	532 12 17-48	Arandela
35	590 60 59-02	Varilla del freno de mano	206	532 44 85-96	Soporte de la travesía
37	532 18 89-67	Arandela	207	587 03 14-02	Cierre del control de travesía
42	532 00 88-83	Cubierta del pedal	208	596 56 41-01	Engranaje
49	596 13 62-01	Perno de 3/8-16 x 3/4	209	590 52 78-02	Travesía del control de Rod
50	532 19 43-27	Polea loca plana	210	588 98 72-02	Ensamble del eje de balancín.
51	873 90 06-00	Tuerca de presión de 3/8-16			Control del pedal
52	532 19 43-26	Polea loca con ranura en V con un desplazamiento	211	532 12 01-83	Buje
56	592 85 52-01	Correa trapezoidal de la transmisión	213	532 40 31-19	Travesía del control de la perilla
			214	532 42 12-63	Almohadilla de pedal, adelante
64	532 19 78-65	Ensamble del eje Control del pedal de freno	215	596 90 83-01	Almohadilla de pedal, cuadrada, reversa
			220	532 19 89-08	Reflector derecho
69	532 42 33-03	Clavija	221	532 40 31-87	Abrazadera de retención del resorte de la manija
70	532 43 96-61	Ensamble de la consola			
73	596 13 65-01	Perno de 5/16-18 x 1-1/2	222	879 21 20-10	Tuerca 21/32 x 1-1/4 x calibre 10
74	596 13 41-01	Tornillo de 1/4-15 x 1/2	225	532 40 33-19	Sujetador de la correa
92	595 30 57-01	Tornillo de 5/16-18 x 1-1/4	227	596 13 59-01	Perno de 5/16-18 x 3/4
99	582 40 45-01	Varilla de desviación	231	532 40 72-87	Polea loca con ranura V
116	596 13 57-01	Tuerca de 5/16-18 x .68	304	588 98 73-02	Montaje de pedal doble, marcha atrás, Tex
125	817 00 05-12	Tornillo 5/16-18 x 3/4			
153	532 00 44-97	Retén del resorte	325	586 43 12-02	Soporte LI
159	596 02 95-01	Pasador de chaveta de 1/8 x 3/4	326	586 00 11-02	Soporte LD
160	596 02 94-01	Abrazadera de retención	334	585 88 22-02	Soporte de varilla de balanceo
161	532 10 57-09	Resorte de retorno del embrague	336	587 25 96-02	Perno de 5/16-18 x 1-3/4
163	588 56 63-01	Barra, pedaldoble, Fwd, K46/K57/K58	344	597 64 72-01	Barra, Dp. Rvs, 48F/54F, K46/K58
166	532 42 91-64	Tuerca	361	597 13 67-01	Casquillo, doble, pedal, marcha atrás, deslizamiento
167	532 40 52-57	Pestillo del freno de mano			
170	532 41 34-30	Fijador de la correa	379	596 58 06-01	Pin de retención 1-7/16 x 0.073
183	532 13 70-57	Separador			
184	587 65 37-01	Manija del freno de mano			
185	872 11 06-22	Perno 3/8-16 x 2-3/4			
186	532 19 43-21	Espaciador de retención			
187	596 13 55-01	Arandela de 13/32 x 2			
188	582 21 70-01	Mecanismo de desplazamiento de la varilla de mando del embrague			

NOTA: Las dimensiones de todos los componentes están expresadas en pulgadas americanas. 1 pulgada = 25,4 mm

TRACTOR MODELO NO. TS 248XD(96043030900), PRODUCTO NO. 960 43 03-09
MOTOR

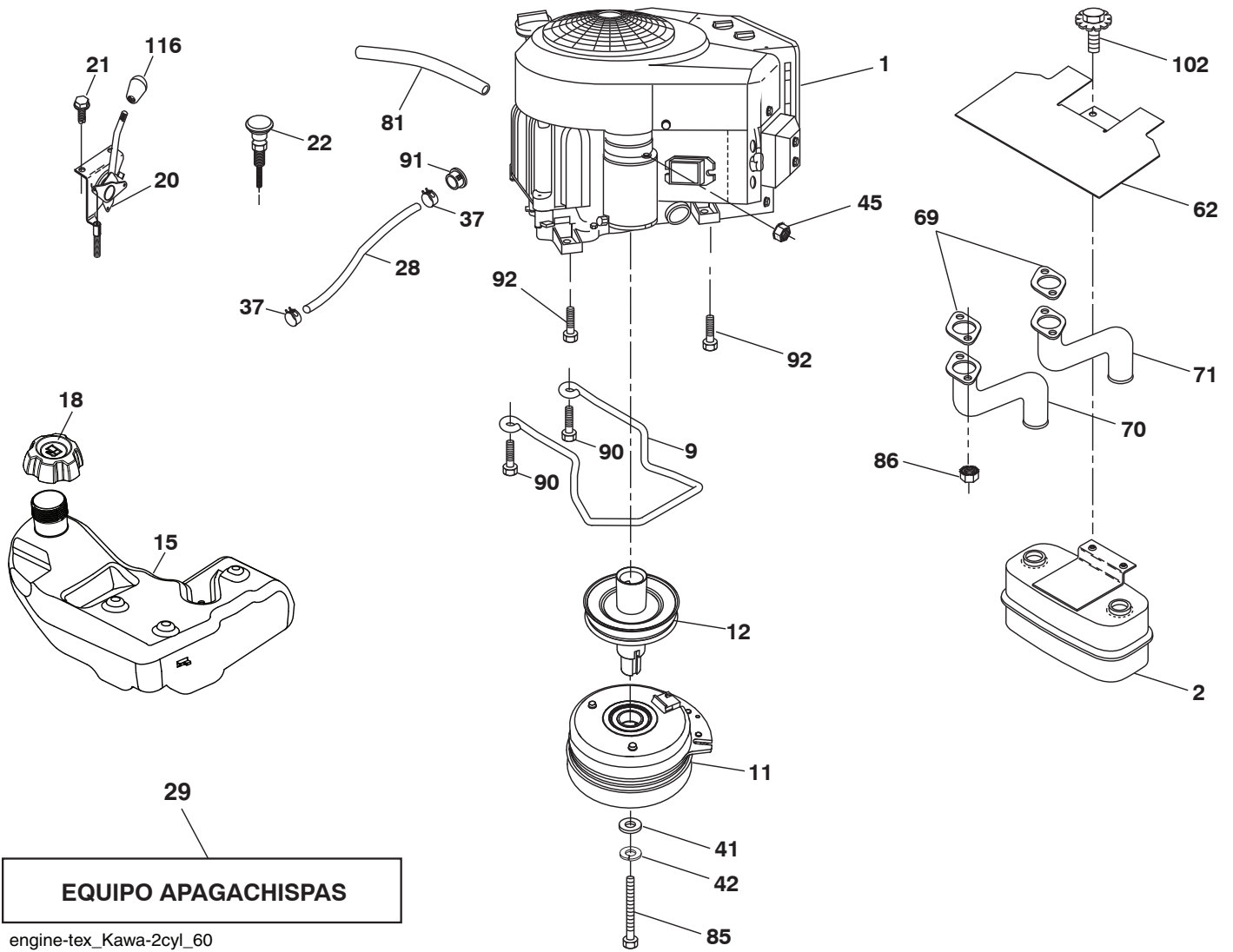

**TRACTOR MODELO NO. TS 248XD(96043030900), PRODUCTO NO. 960 43 03-09
MOTOR**

CÓDIGO No.	PIEZA No.	DESCRIPCIÓN
1	---	Motor Kawa modelo No. FR691-DS15 (581557501)(Haga el pedido de las piezas al fabricante del motor.)
2	589 81 87-01	Silenciador
9	501 83 26-02	Ensamble del sujetador de la correa del motor
11	587 25 50-01	Embrague de eléctrico
12	586 89 96-01	Polea del motor
15	532 43 80-29	Tanque de Gasolina
18	585 12 48-18	Tapa
20	532 42 43-41	Control del regulador
21	596 32 17-01	Tornillo de #10 x 0.750
22	532 18 95-41	Control del obturador
28	532 40 11-35	Línea de combustible
29	532 13 71-80	Equipo apagachispas
37	532 12 34-87	Abrazadera de la manguera
41	532 12 61-97	Arandela 1-1/2 x 15/32 x .250
42	596 23 89-01	Arandela de 7/16"
45	596 13 36-01	Tuerca de presión de 1/4-20
62	532 43 40-17	Silenciador con pantalla térmica
69	532 17 81-51	Junta
70	583 95 56-01	Tubo de escape izquierdo
71	583 95 57-01	Tubo de escape derecho
81	532 14 84-56	Tubo de fácil drenaje de aceite
85	501 60 67-01	Perno 7/16-20 x 5 Gr. 5
86	532 18 43-62	Tuerca brida hexagonal
90	817 00 06-16	Tornillo de 3/8-16 x 1
91	532 18 74-95	Buje
92	817 12 06-16	Tornillo 3/8-16 x 1
102	817 00 05-12	Tornillo 5/16-18 x 3/4
116	539 13 26-24	Tacto suave de la perilla

NOTA: Las dimensiones de todos los componentes están expresadas en pulgadas americanas. 1 pulgada = 25,4 mm

Para las piezas del servicio y de recambio del motor, llame el número gratis para su fabricante del motor enumerado abajo:
Kawasaki 1-949-460-5688

TRACTOR MODELO NO. TS 248XD(96043030900), PRODUCTO NO. 960 43 03-09
ENSAMBLE DE LA DIRECCIÓN

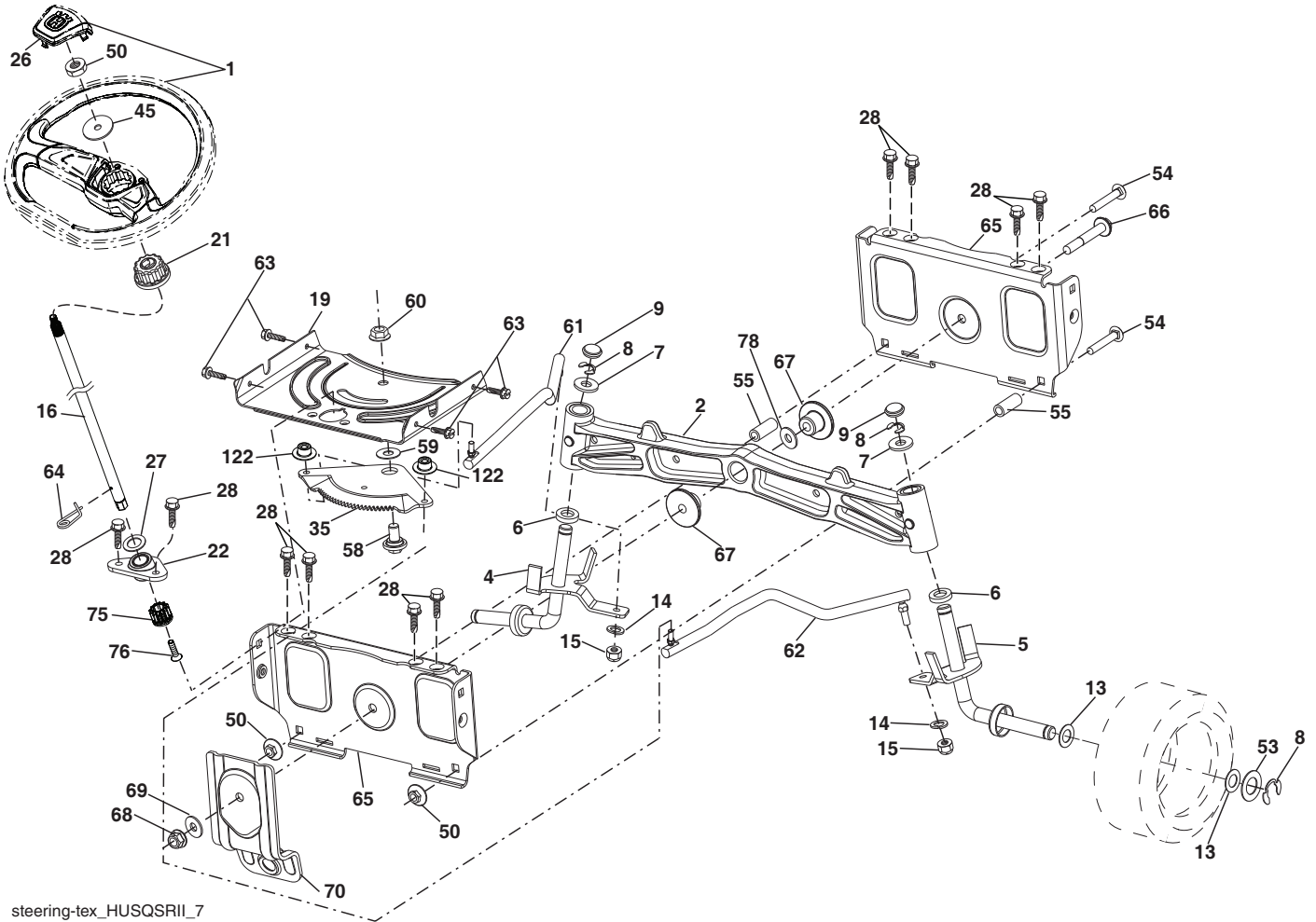

steering-tex_HUSQSR11_7

**TRACTOR MODELO NO. TS 248XD(96043030900), PRODUCTO NO. 960 43 03-09
ENSAMBLE DE LA DIRECCIÓN**

CÓDIGO No.	PIEZA No.	DESCRIPCIÓN
1	597 86 61-01	Kit, rueda, dirección (Incluye volante y tapa del volante)
2	532 19 59-68	Ensamble del eje delantero
4	532 40 30-89	Ensamble del husillo izquierdo
5	532 40 30-90	Ensamble del husillo derecho
6	532 00 62-66	Arandela .75 x 1.230
7	532 12 17-48	Arandela de 25/32 x 1-5/8 calibre 16
8	812 00 00-29	Abrazadera del aro No. T5304-75
9	532 12 12-32	Tapa del husillo
13	532 12 17-49	Arandela de 25/32 x 1-1/4 calibre 16
14	596 23 87-01	Arandela de .381 x .680
15	873 54 06-00	Tuerca de 3/8-24 unf
16	587 01 60-02	Eje de dirección
19	532 19 47-29	Placa de dirección
21	586 84 02-01	Adaptador del volante de dirección
22	585 02 98-02	Rodamiento
26	594 94 91-01	Volante de dirección
27	596 93 34-01	Arandela
28	817 00 06-12	Tornillo de 3/8-16 x 3/4
35	532 19 47-32	Engranaje del sector de la placa
45	587 01 64-01	Arandela 3/8 ID 2-3/8 OD calibre 12 PLTD
50	873 90 06-00	Tuerca 3/8-16 unc
53	532 18 89-67	Arandela reforzada de, 793 x 1,637 x 0,060
54	874 76 06-36	Tornillo 3/8-16 unc x 2-1/4
55	532 41 47-36	Tornillo 3/8-16 unc x 2-1/4
58	532 19 47-47	Perno de tope del sector del pivote CFM
59	532 19 47-48	Arandela de empuje del sector de dirección
60	873 97 10-00	Tuerca de 5/8-11
61	597 07 02-02	Barra de acoplamiento izquierda
62	597 07 03-02	Barra de acoplamiento derecha
63	817 00 05-12	Tornillo de 5/16-18 x 3/4
64	532 19 98-49	Abrazadera de retención del resorte de la dirección
65	532 19 47-34	Apoyo del árbol delantero
66	871 02 07-48	Perno de cabeza hexagonal con brida acanalada de 7/16-14 x 3
67	532 19 47-37	Buje PM del eje delantero
68	873 90 07-00	Tuerca de 7/16-14 grado 5
69	532 19 91-62	Arandela de 1,5 x 0,505 x 0,118
70	585 33 88-01	Soporte de la plataforma delantera
75	580 68 37-01	Piñón
76	580 68 36-01	Tornillo
78	532 05 70-79	Tuerca
122	532 44 49-62	Tapa

NOTA: Las dimensiones de todos los componentes están expresadas en pulgadas americanas. 1 pulgada = 25,4 mm

TRACTOR MODELO NO. TS 248XD(96043030900), PRODUCTO NO. 960 43 03-09
PLATAFORMA DE LA CORTADORA DE CÉSPED

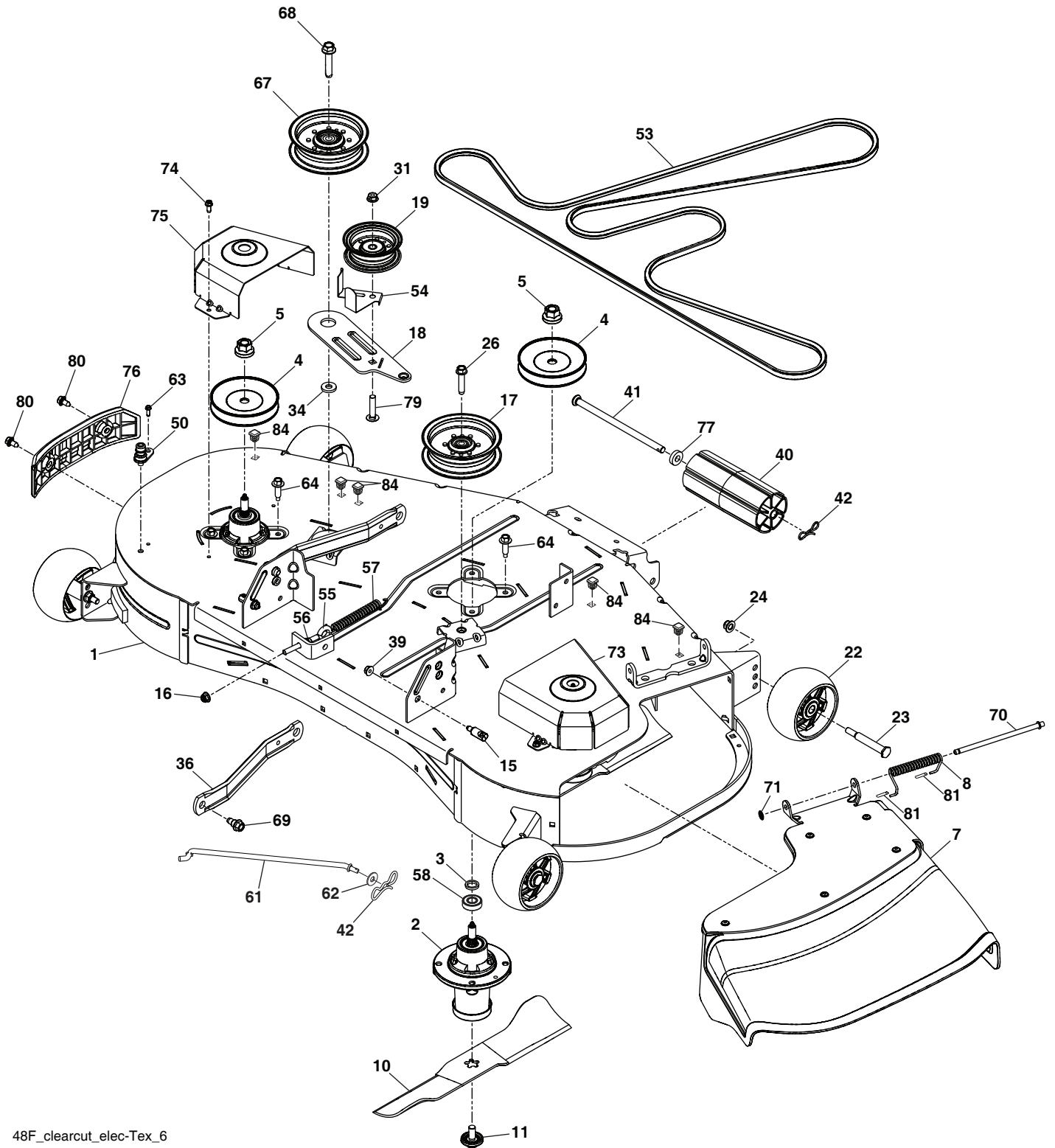

48F_clearcut_elec-Tex_6

**TRACTOR MODELO NO. TS 248XD(96043030900), PRODUCTO NO. 960 43 03-09
PLATAFORMA DE LA CORTADORA DE CÉSPED**

CÓDIGO No.	PIEZA No.	DESCRIPCIÓN	CÓDIGO No.	PIEZA No.	DESCRIPCIÓN
1	583 81 00-01	Kit, SVC, 48F	56	596 03 92-01	Tuerca de presión de 5/16-18
2	539 13 18-98	Ensamble de la cubierta	57	587 35 84-01	Resorte
3	532 18 76-90	Arandela	58	532 11 04-85	Rodamiento de bolitas
4	532 17 34-34	Polea	61	532 44 32-37	Varilla
5	596 13 48-01	Tuerca de 9/16-18 x 1.010	62	596 13 32-01	Arandela de 13/32 x 13/16 x 12 Calibre
7	593 64 97-01	Deflector	63	817 49 04-10	Tornillo 1/4-20 x 5/8
8	587 35 47-01	Resorte - torsión	64	584 95 39-01	Perno .313-18 x 1.19
10	588 81 10-02	Cuchilla	67	532 19 61-06	Polea
11	532 19 30-03	Perno, 7/16-20	68	596 56 40-03	Perno de 3/8-16 x 1.78
15	532 19 51-61	Sujetador del perno prisionero	69	532 19 65-39	Perno
16	594 94 44-01	Tuerca de 5/16-18	70	595 29 70-01	Varilla de la bisagra
17	532 19 61-04	Polea más ociosa	71	532 11 04-52	Tuerca
18	588 81 22-02	Brazo más ocioso	73	588 81 24-02	Cubierta del mandril lado derecho
19	532 19 31-97	Polea más ociosa	74	532 13 77-29	Tornillo 1/4-20 x 5/8
22	589 52 73-01	Rueda, calibrador	75	588 81 31-02	Cubierta del mandril lado izquierdo
23	596 43 44-04	Perno de 3/8-16 x 3-5/8	76	582 54 11-03	Guarnición
24	521 99 65-02	Tuerca 3/8-16	77	582 36 05-01	Buje
26	588 43 83-01	Tornillo 7/16-14 x 2.125	79	596 13 62-01	Perno de 3/8-16 x 3/4
31	873 90 06-00	Tuerca 3/8-16	80	532 17 01-65	Perno 5/16
34	532 17 85-15	Arandela	81	532 10 53-04	Tapa
36	587 14 05-02	Suspensión posterior del brazo	84	596 95 22-01	agujero de enchufe, cuadrado
39	596 13 57-01	Tuerca de presión de 5/16-18 x .68	--	532 41 64-05	Accesorio del conexión
40	532 17 60-66	Rodillo de la nariz			
41	594 09 25-01	Varilla de rodillo estrecho			
42	532 19 42-08	Pasador de chaveta			
50	532 41 55-98	Puerto del derrubio			
53	588 81 43-01	Correa, cubierta			
54	532 14 10-43	Protector, correa			
55	596 24 08-01	Perno de argolla 5/16 x 3-1/2			

NOTA: Las dimensiones de todos los componentes están expresadas en pulgadas americanas. 1 pulgada = 25,4 mm

**TRACTOR MODELO NO. TS 248XD(96043030900), PRODUCTO NO. 960 43 03-09
ELEVACIÓN DE LA CORTADORA DE CÉSPED**

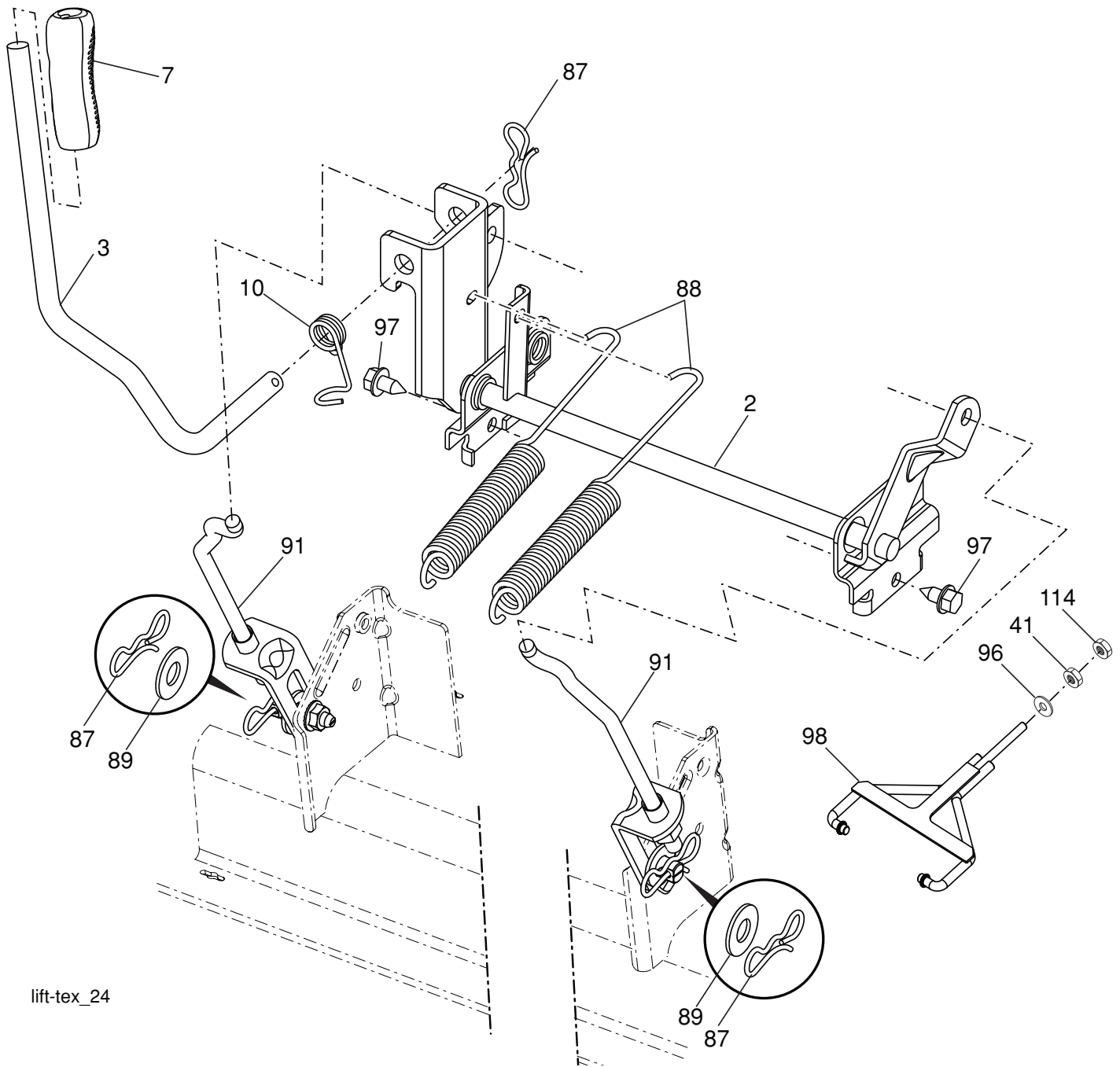

lift-tex_24

CÓDIGO No.	PIEZA No.	DESCRIPCIÓN
2	532 42 20-27	Ensamble del eje de la elevación
3	596 27 06-01	Ensamble de la palanca de elevación
7	580 96 23-01	Mango de la palanca
10	532 19 63-14	Resorte de torsión
41	589 46 49-02	Tuerca
87	532 19 42-09	Pasador de chaveta de 7/16 con bloqueo en forma de mariposa
88	532 41 07-10	Resorte de ayuda de la elevación
89	819 19 19-12	Arandela de zinc transparente
91	589 46 48-05	Ensamble del acoplamiento Elevación trasera

CÓDIGO No.	PIEZA No.	DESCRIPCIÓN
96	593 84 21-01	Buje
97	817 00 06-12	Tornillo de 3/8-16 x 0,75
98	574 82 25-01	Acoplamiento frontal de la elevación de la cortadora de césped
114	873 36 07-00	Tuerca 7/16-20

NOTA: Las dimensiones de todos los componentes están expresadas en pulgadas americanas. 1 pulgada = 25,4 mm

TRACTOR MODELO NO. TS 248XD(96043030900), PRODUCTO NO. 960 43 03-09 ENSAMBLE DEL ASIENTO

*OPCIONAL

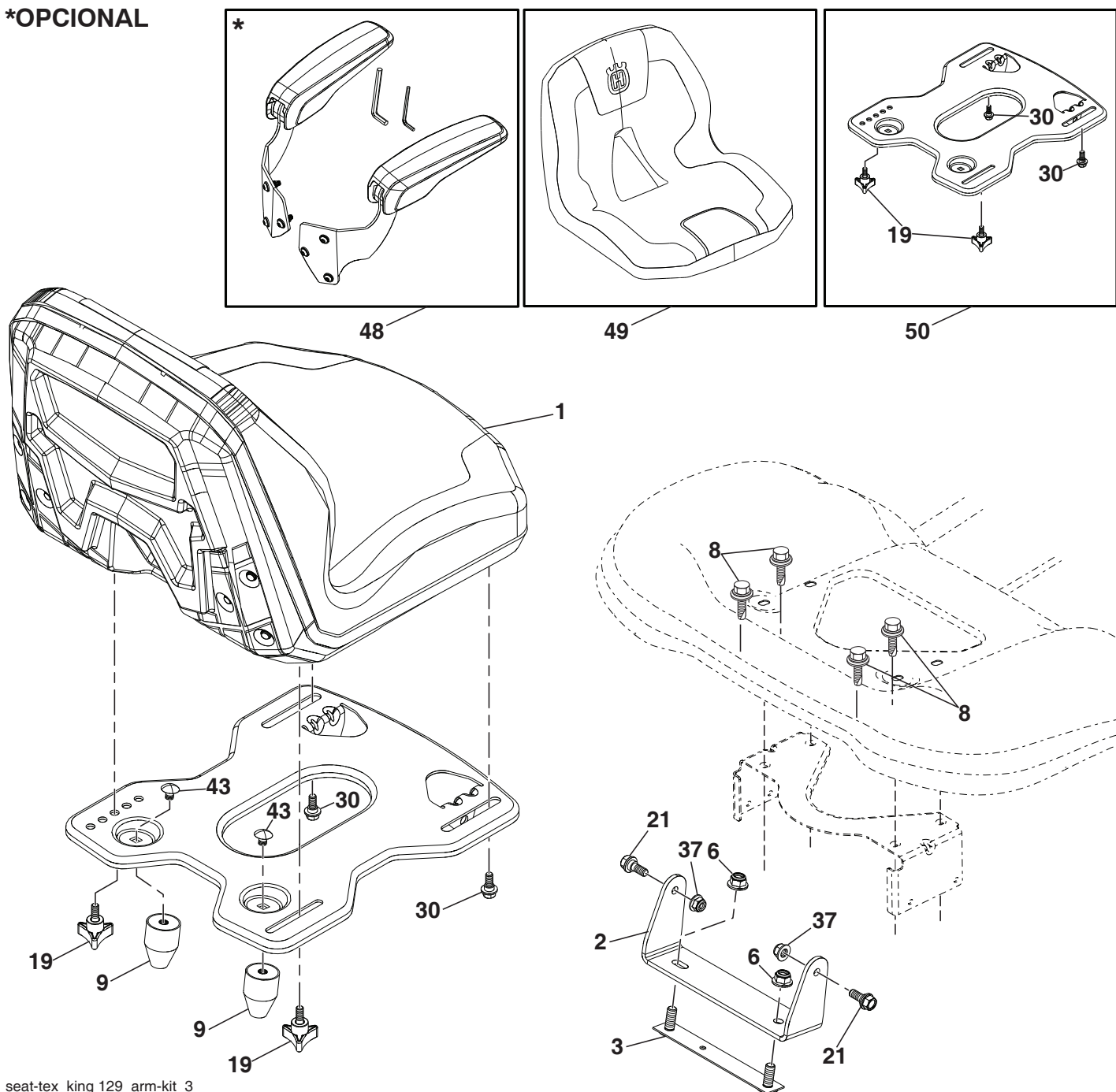

seat-tex_king 129_arm-kit_3

CÓDIGO No.	PIEZA No.	DESCRIPCIÓN
1	597 65 81-01	Asiento, SK150/129w/o apoyabrazos
2	597 32 99-02	Soporte PNT, PVT, FNDR, asiento, EDIP
3	590 77 76-02	Refuerzo de montaje de soporte, FNDR, EDIP
6	521 99 65-02	Tuerca, hexagonal, bloqueo w/brida
8	532 17 18-77	Perno 5/16-18 unc x 3/4 w/Sems
9	597 78 51-01	Parachoques, caucho, aislador
19	597 78 31-01	Pomo, 3 alas 5/16-18, CLR, ZN
21	596 24 07-01	Perno hexagonal 5/16-18 x 21/32
30	597 78 18-01	Perno hexagonal hombro 5/16-18 unc ZPB
37	594 94 44-01	Tuerca hexagonal brida 5/16-18

CÓDIGO No.	PIEZA No.	DESCRIPCIÓN
43	597 86 93-01	Perno de carro cuadrado 3/8 x .45 CLR, ZN
48	597 65 82-03	Kit de servicio brazo de asiento de 15"
49	597 95 94-01	Funda de asiento Husqvarna 5 pulgadas (Sk129)
50	598 00 16-01	Kit de placa de montaje del asiento (incluye todos los componentes ilustrados en la caja para la Clave# 50)

NOTA: Las dimensiones de todos los componentes están expresadas en pulgadas americanas. 1 pulgada = 25,4 mm

**TRACTOR MODELO NO. TS 248XD(96043030900), PRODUCTO NO. 960 43 03-09
CALCOMANÍAS**

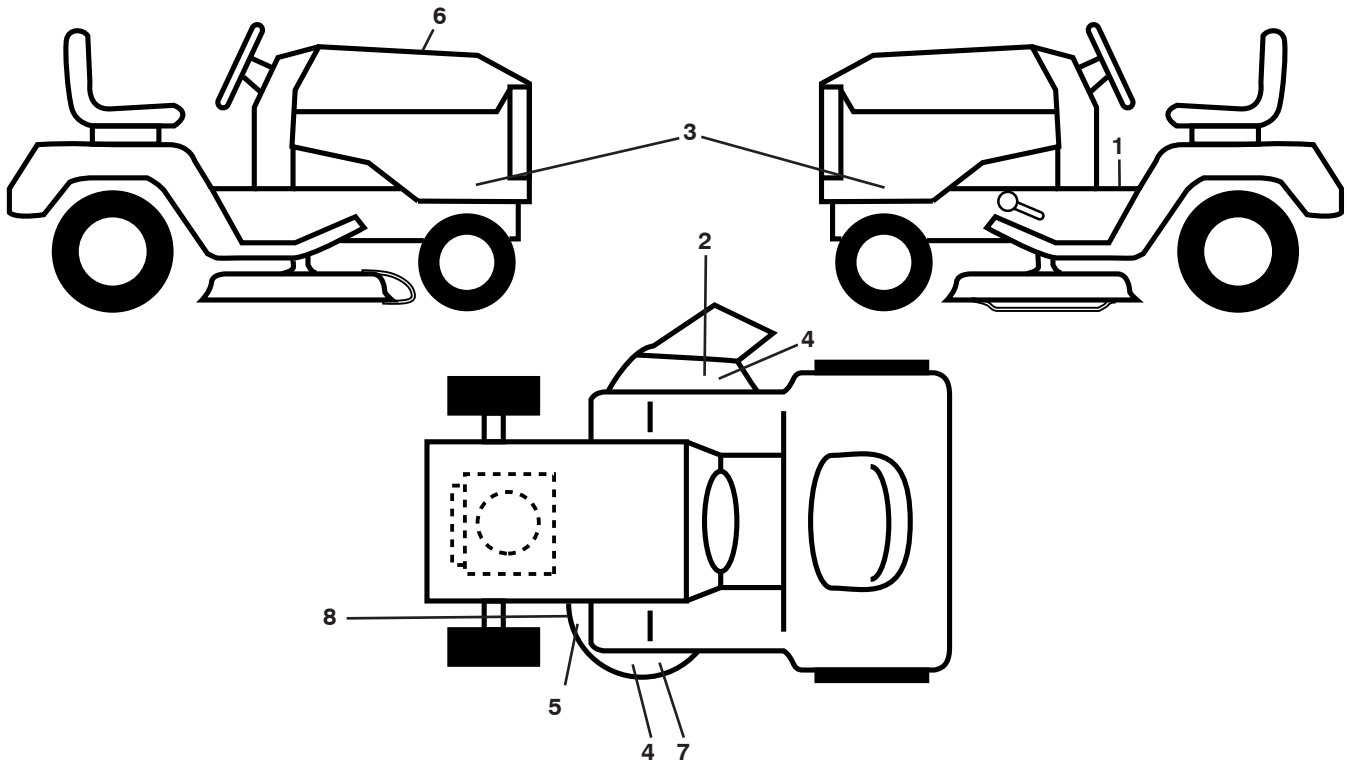

CÓDIGO No.	PIEZA No.	DESCRIPCIÓN	CÓDIGO No.	PIEZA No.	DESCRIPCIÓN
1	581 57 90-01	Calcomanía, Advertencia	--	532 43 98-82	Forro del apoyo para los pies izquierdo
2	586 97 88-01	Calcomanía, Advertencia	--	532 44 15-42	Forro del apoyo para los pies derecho
3	598 01 05-01	Calcomanía, panel	--	114 19 33-49	Manual del operario (Inglés/Español)
4	589 35 79-01	Calcomanía, no paso	--	114 19 34-32	Manual del operario (Français)
5	585 91 01-01	Calcomanía garantía	--	114 19 14-49	Manual IPL (Inglés/Español)
6	589 41 37-01	Calcomanía, de reemplazo	--	587 71 00-26	Guía rápida (Inglés/Español)
7	590 88 50-01	Calcomanía, corte claro de cubierta	--	587 71 01-26	Guía rápida (Inglés/Français)
8	581 58 00-02	Calcomanía, del diagrama de la			
--	501 74 90-01	Calcomanía, diferencial de bloqueo			
--	581 72 48-01	Calcomanía, para la desviación			

WHEELS AND TIRES

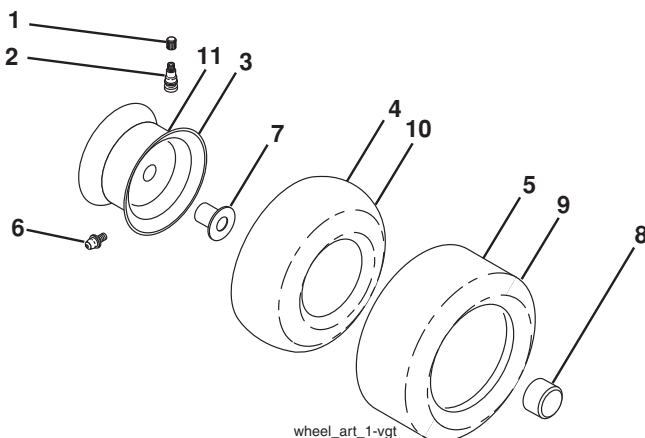

CÓDIGO No.	PIEZA No.	DESCRIPCIÓN
1	532 05 91-92	Tapa de la válvula del neumático
2	532 06 51-39	Vástago de la válvula
3	532 18 18-39	Ensamble de las llantas delanteras
4	532 00 81-34	Cámara delantera
5	532 16 10-24	Neumático delantero 16 x 6.5-8
6	532 00 02-78	Accesorio para engrasar (solo para la rueda delantera)
7	532 00 90-40	Rodamiento de la brida (solo para la rueda delantera)
8	532 17 50-39	Tapa del eje
9	532 17 04-53	Neumático trasero 20 x 10-8
10	532 00 71-52	Cámaratrasera (Mantenimientosólo)
11	532 14 45-10	Ensamble trasero de la llanta
--	532 14 43-34	Sellador para neumáticos (tubo de 10 onzas [283 gr])

NOTA: Las dimensiones de todos los componentes están expresadas en pulgadas americanas. 1 pulgada = 25,4 mm

NOTES/AVISO



www.husqvarna.com