

Repair Parts Manual
Manual De Repuestos
TS 354XD / 96043030500

Please read the operator's manual carefully and make sure you understand the instructions before using the machine.

Por favor lea cuidadosamente y comprenda estas instrucciones antes de usar esta maquina.



English/Spanish

114 19 18-27



HOW TO USE THIS MANUAL

This manual is designed to provide the customer with a means to identify the parts on his/her tractor when ordering repair parts. The illustrations may or may not represent the actual assemblies; therefore, it is not recommended to use this manual as a guide to assemble or disassemble the tractor. Some hardware and parts are drawn larger in order to more readily identify them.

Each tractor has its own model number. The model number for your tractor can be found on the fender under the seat.

Support / Help

If you require assistance or have questions concerning the application, operation, maintenance or parts for your product:

- Visit our website: www.husqvarna.com
- Call Us Toll Free: 1-800-487-5951

When ordering parts, always give the following information:

- Product - "TRACTOR"
- MODEL NUMBER - "TS 354XD"(96043030500)"
- Part Number
- Part Description

TABLE OF CONTENTS

SCHEMATIC	3
ELECTRICAL.....	4-5
CHASSIS	6-7
DRIVE.....	8-9
ENGINE.....	10-11
STEERING	12-13
MOWER DECK	14-15
MOWER LIFT.....	16
SEAT	17
DECALS.....	18
ESPAÑOL	20

TRACTOR - MODEL NO. TS 354XD (96043030500), PRODUCT NO. 960 43 03-05 SCHEMATIC

SCH27

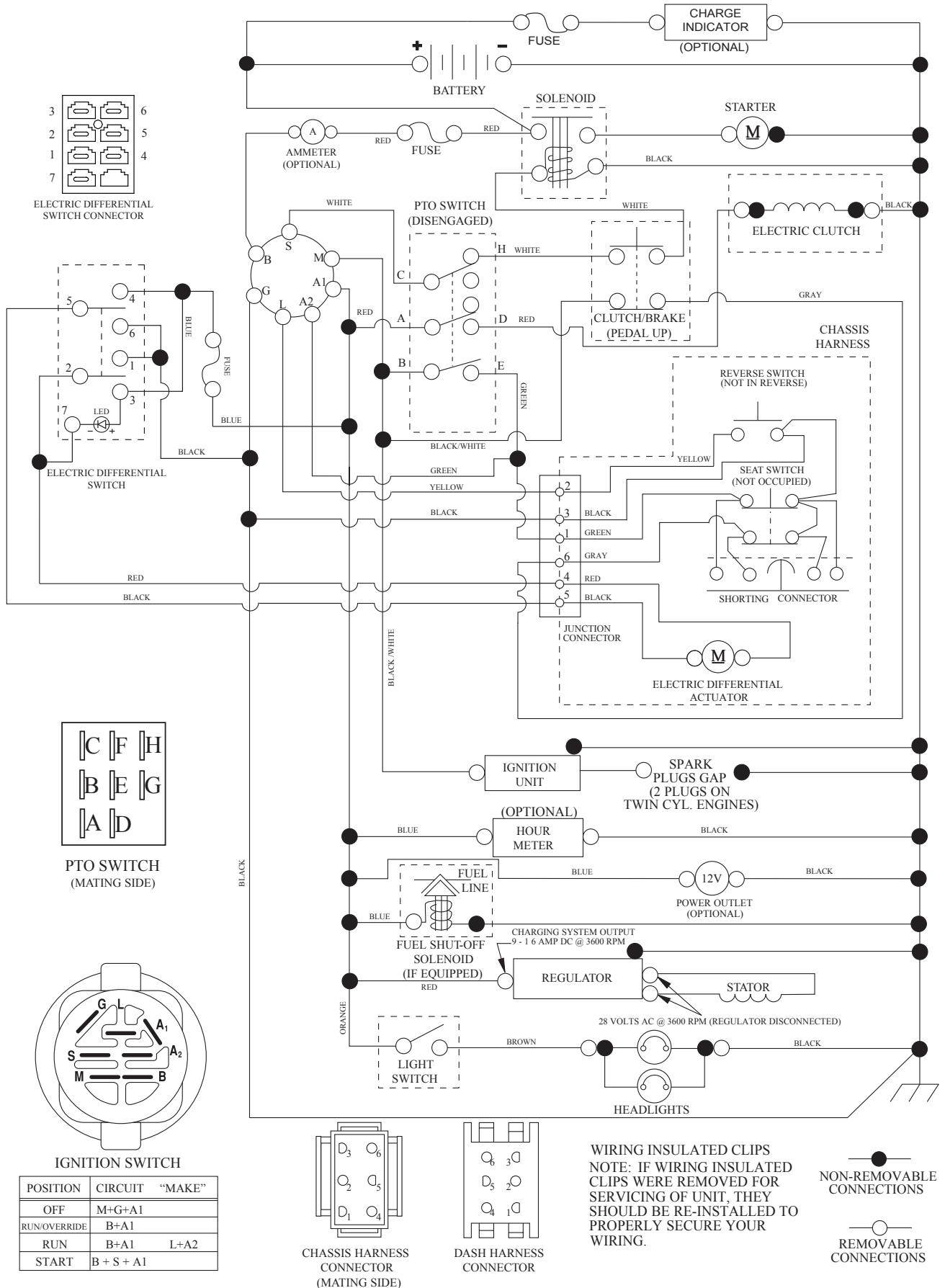

**TRACTOR - MODEL NO. TS 354XD (96043030500), PRODUCT NO. 960 43 03-05
ELECTRICAL**

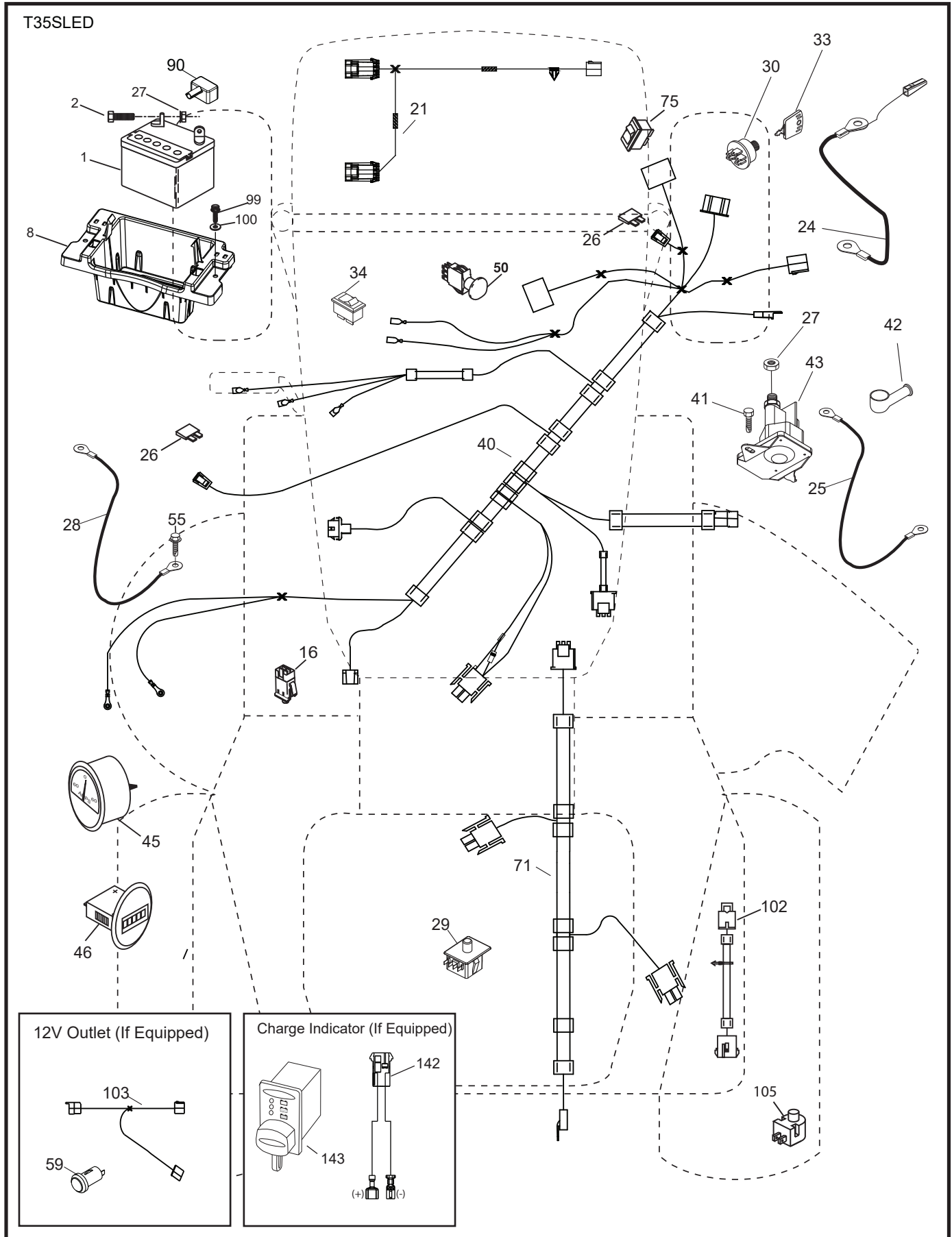

**TRACTOR - MODEL NO. TS 354XD (96043030500), PRODUCT NO. 960 43 03-05
ELECTRICAL**

KEY NO.	PART NO.	DESCRIPTION
1	532 16 34-65	Battery
2	874 76 04-12	Bolt Hex Hd 1/4-20 unc x 3/4
8	532 41 41-26	Battery Tray
16	532 17 61-38	Switch Interlock
21	585 43 64-01	Harness Light
24	585 55 56-01	Cable FR Batt
25	585 55 55-01	Cable Starter
26	532 17 51-58	Fuse
27	873 51 04-00	Nut Keps Hex 1/4-20 unc
28	532 41 65-88	Cable Ground
29	532 19 27-49	Switch Seat
30	532 19 33-50	Switch Ign
33	532 41 19-35	Key/Chain
34	532 11 07-12	Switch Light/Reset
40	501 13 36-01	Harness Ign. Dash
41	817 72 04-08	Screw 1/4-20 unc x 1/2
42	532 13 15-63	Cover Terminal Red
43	582 04 28-01	Solenoid
45	587 55 39-03	Ammeter
46	587 55 40-03	Gauge Hourmeter
50	582 10 76-02	Switch PTO
55	817 06 05-12	Screw Thdrol 5/16-18 x 3/4
59	532 40 03-03	Outlet 12-Volt
71	580 51 30-01	Harness Ign Chassis
75	580 36 64-01	Switch ON/OFF Diff Lock
90	532 43 53-95	Cover Terminal Battery
99	817 67 04-12	Screw Hexwsh Thdrol 1/4-20 x 3/4
100	819 09 14-16	Washer 9/32 x 7/8 x 16 Ga.
102	532 40 44-54	Harness, Pigtail K46 ROS
103	532 42 17-47	Harness, Pigtail
105	532 40 75-68	Switch Reverse

NOTE: All component dimensions given in U.S. inches
1 inch = 25.4 mm

TRACTOR - MODEL NO. TS 354XD (96043030500), PRODUCT NO. 960 43 03-05 CHASSIS

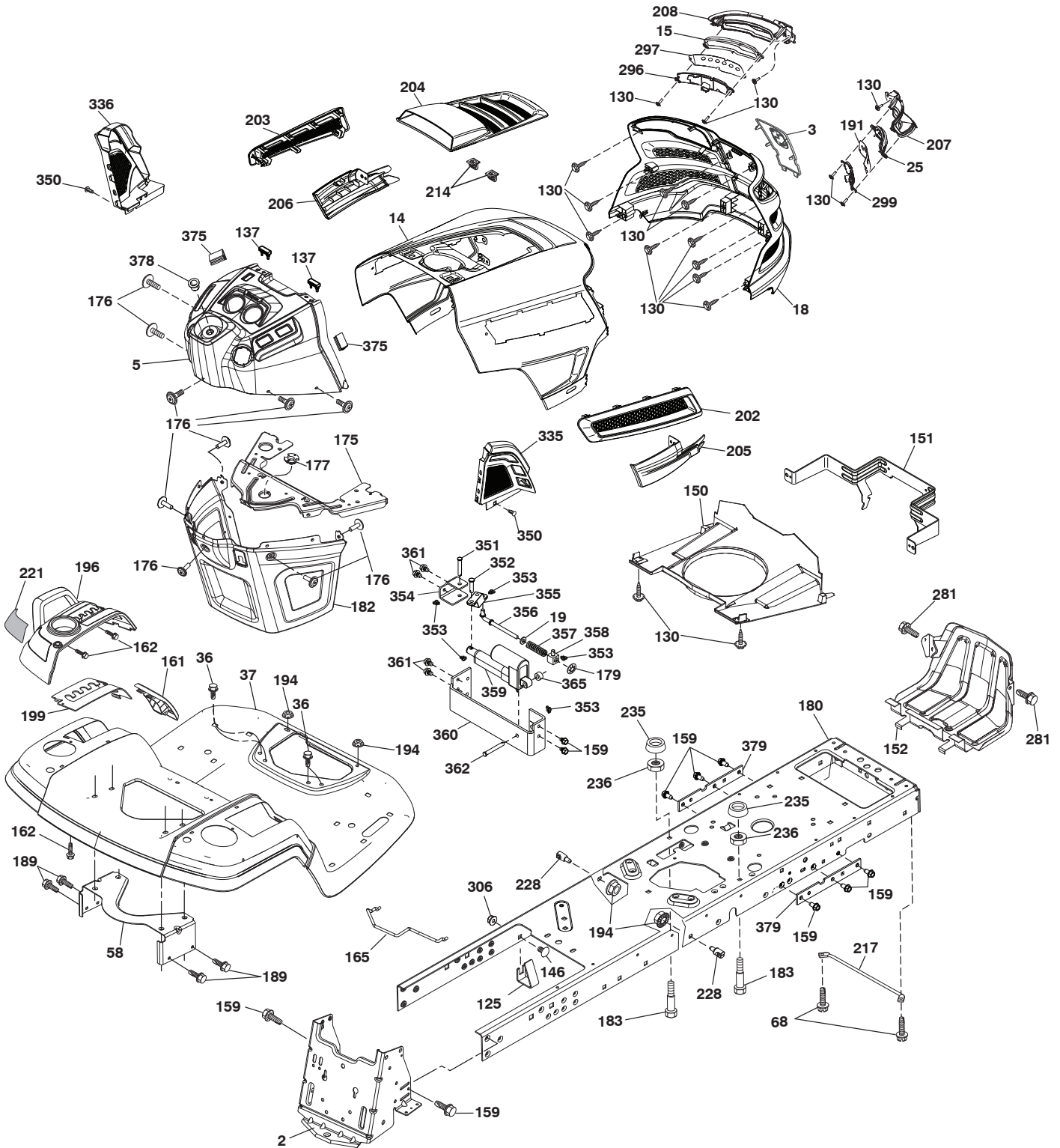

chassis-tex_GT HUSQ_II_261

**TRACTOR - MODEL NO. TS 354XD (96043030500), PRODUCT NO. 960 43 03-05
CHASSIS**

KEY NO.	PART NO.	DESCRIPTION	KEY NO.	PART NO.	DESCRIPTION
2	580 43 44-01	Drawbar	205	532 43 97-30	Skirt Hood Side RH
3	532 44 44-81	Logo Husq.	206	532 43 97-29	Skirt Hood Side LH
5	590 74 88-19	Dash	207	585 42 00-02	Bezel RH
14	532 44 11-77	Hood	208	585 42 01-02	Bezel LH
15	585 42 03-01	Lens LH	214	532 19 91-45	Clip Retainer
18	587 52 34-01	Grille	217	532 40 91-67	Rod Pivot
19	819 13 13-12	Washer 13/32 x 13/16 x 12 Ga.	221	532 19 89-09	Reflector LH
25	585 42 02-01	Lens RH	228	532 19 51-61	Stud Fastener
36	817 06 05-12	Screw 5/16-18 x 3/4	235	532 40 61-29	Spacer Fender
37	532 44 12-08	Fender	236	873 93 05-00	Nut Center Lock 5/16-18 unc
58	532 19 43-14	Bracket Fender	281	817 00 06-16	Screw 3/8-16 x 1
68	539 99 08-58	Screw 5/16-18 x 1/2	296	585 42 05-01	LED Light LH
125	581 68 48-01	Clip Fuel Line	297	586 18 29-01	Insert Reflect. LH
130	532 41 63-58	Screw #10 x 0.750 BOS Thread	299	585 42 04-01	LED Light RH
137	532 40 75-90	Bumper Dash	306	873 90 06-00	Nut Lock
146	581 85 79-01	Bolt	335	532 44 82-04	Cover RH Lower
150	532 43 97-74	Duct Heat Hood	336	532 44 53-09	Cover LH Lower
151	532 43 66-70	Bracket Pivot Hood	350	532 44 51-43	Clip X-mas Tree
152	532 43 98-70	Shield Browning	351	532 42 17-34	Pin Clevis .375 x 2.125
159	817 00 06-12	Screw 3/8-16 x 3/4	352	532 44 86-34	Clevis .375 x 2.125
161	532 43 99-29	Fuel Window	353	532 17 80-62	Clip Retainer .0375
162	532 14 24-32	Screw Hex Wsh Hi-Lo 1/4 x 1/2	354	532 44 86-19	Support Bellcrank
165	532 19 43-30	Bracket Support Tank	355	532 44 86-36	Bellcrank Pivot Lock Diff
175	590 60 77-02	Crossmember	356	532 44 86-93	Link Lock Diff
176	532 40 07-76	Screw 10-24 x 5/8 Wshd Qdrx	357	532 44 86-84	Spring Compression
177	532 19 52-28	Bushing Steering	358	580 36 66-01	Swivel Guide
179	532 16 89-37	Nut Push	359	584 39 34-01	Actuator Electric
180	593 34 63-01	Chassis	360	532 44 86-18	Bracket Actuator
182	532 40 68-59	Dash Lower	361	817 49 06-10	Screw Hxwsh Thdr 3/8-16 x 5/8
183	874 52 05-20	Bolt 5/16-18 x 1-1/4	362	532 44 86-33	Clevis .375 x 2.42
189	817 00 05-12	Screw 5/16-18 x 3/4	365	532 44 73-68	Nylon Spacer .375 x .4375L
191	586 18 28-01	Insert Reflect. RH	375	586 90 82-01	Dash Clip-On Bumper
194	873 90 05-00	Nut Lock Hex Flange 5/16-18	378	590 84 98-01	Bushing Flange
196	532 43 96-74	Console Asm. Deck Lift	379	593 20 69-02	Chassis Plate Reinforcement
199	532 19 82-59	Plate Deck Lift	- -	532 43 18-82	Bumper
202	532 43 97-28	Vent Side Hood RH			
203	532 43 97-27	Vent Side Hood LH			
204	532 43 57-14	Vent Asm Hood Top			

NOTE: All component dimensions given in U.S. inches
1 inch = 25.4 mm

TRACTOR - MODEL NO. TS 354XD (96043030500), PRODUCT NO. 960 43 03-05
DRIVE

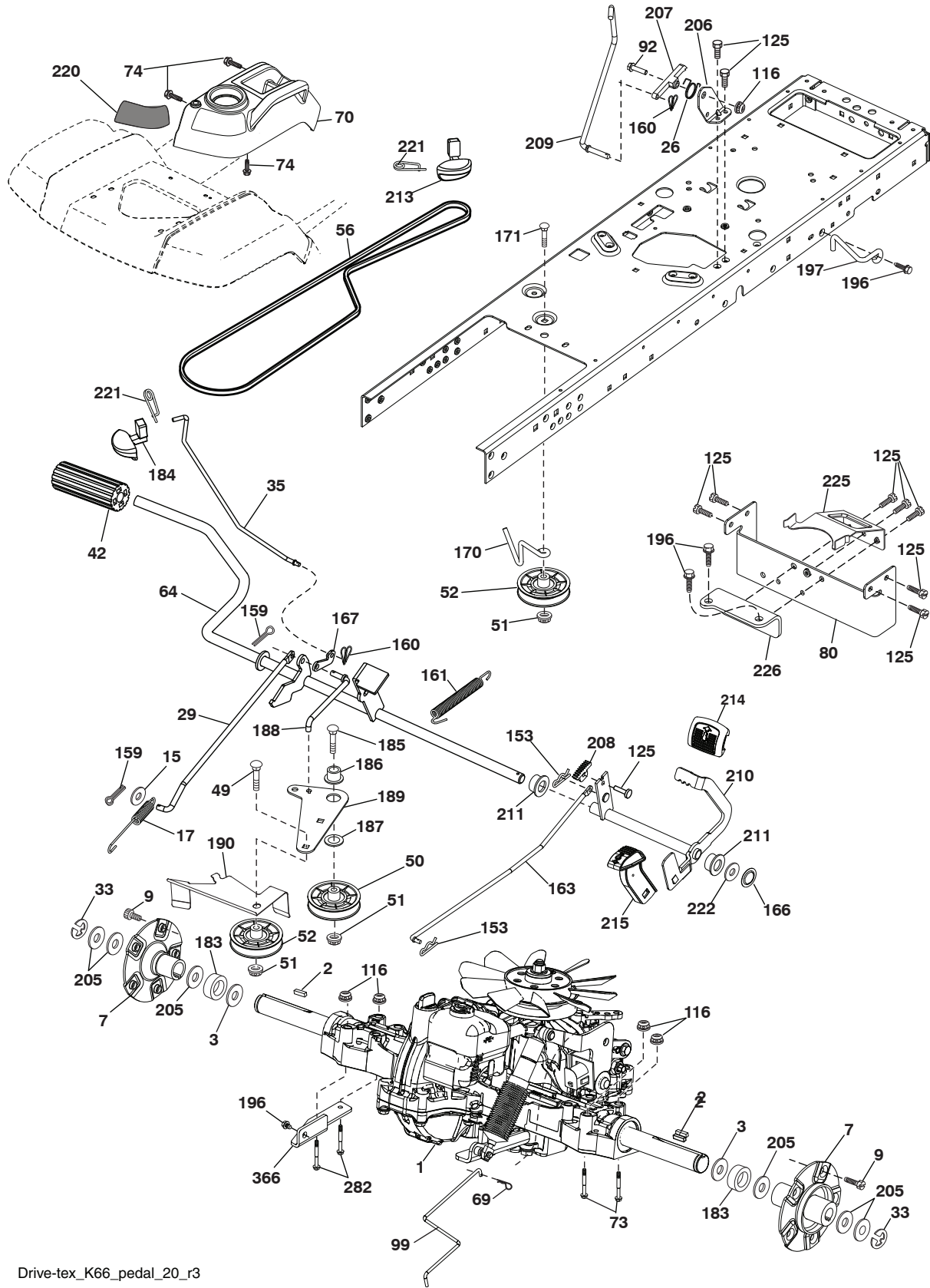

Drive-tex_K66_pedal_20_r3

**TRACTOR - MODEL NO. TS 354XD (96043030500), PRODUCT NO. 960 43 03-05
DRIVE**

KEY NO.	PART NO.	DESCRIPTION	KEY NO.	PART NO.	DESCRIPTION
1	-----	Transaxle, Tufftorq K66ELD (580402201) (Order parts from transaxle manufacturer.)	167	532 40 52-57	Latch Brake Parking
2	539 91 27-57	Key .25 x 1.25	170	532 19 43-22	Keeper V-Idler Centerspan
3	532 00 75-63	Washer Thrust Axle Hardened	171	872 11 06-16	Bolt Rd Hd Sq NK 3/8-16 unc x 2
7	586 93 54-02	Hub Asm. Wheel	183	587 58 74-01	Spacer Axle
9	532 14 00-80	Bolt Hub Wheel	184	587 65 37-01	Handle Parking Brake
15	819 13 13-16	Washer 13/32 x 13/16 x 16 Ga.	185	872 11 06-22	Bolt Rdhd 3/8-16 unc x 2-3/4 G5
17	532 40 10-72	Spring, Brake	186	532 19 43-21	Spacer Retainer
26	532 19 96-79	Spring Return Cruise	187	819 13 32-10	Washer
29	532 40 72-45	Rod, Brake	188	582 21 70-01	Link Clutch Ground Drive, Long
33	812 00 00-53	Ring E	189	532 19 43-17	Bellcrank Ground Drive
35	590 60 59-02	Rod, Brake, Park	190	532 19 43-18	Keeper Bellcrank Ground Drive
42	532 00 88-83	Cover, Foot Pedal	196	817 00 06-16	Screw 3/8-16 x 1
49	872 11 06-14	Bolt	197	585 65 86-01	Bracket Clutch Anti-Rotation
50	532 19 43-27	Pulley Idler Flat	205	532 12 38-00	Washer 1-1/32 x 1-5/8 x 16 Ga.
51	873 90 06-00	Lock Nut 3/8-16	206	532 44 85-96	Bracket Mount Latch Cruise
52	532 19 43-26	Idler V-Groove	207	587 03 14-01	Latch Control Cruise
56	592 85 53-01	V-Belt, Drive	208	532 19 78-69	Gear Sector Control Cruise
64	532 19 78-65	Shaft Asm. Pedal Brake Control	209	590 52 78-02	Rod Control Cruise
69	532 42 33-03	Hairpin .059 x 1.125	210	532 19 78-60	Rocker Asm. Pedal Control
70	532 43 96-61	Console Asm	211	532 12 01-83	Bearing Nylon
73	874 49 05-44	Bolt Hex Flghd 5/16-18 Gr. 5	213	532 40 31-19	Knob Control Cruise
74	532 14 24-32	Screw 1/4 x 1/2	214	532 42 12-63	Pedal Forward
80	589 33 34-02	Strap Torque	215	586 60 65-02	Pedal Reverse
92	874 76 05-20	Bolt 5/16-18 x 1/2	220	532 19 89-08	Reflector RH
99	582 40 47-01	Spring Bypass	221	532 40 31-87	Retainer Spring Clip Handle
116	873 90 05-00	Nut Lock Hex Flange 5/16-18	222	879 21 20-10	Washer 21/32 x 1-1/4 x 10 Ga.
125	817 00 05-12	Screw 5/16-18 x 3/4	225	532 40 73-11	Keeper Belt
153	532 00 44-97	Retainer Spring	226	532 40 71-09	Bracket Mount Torque
159	876 02 04-12	Pin Cotter 1/8 x 3/4	282	874 49 05-48	Bolt 5/16-18 x 3.0 G5
160	532 16 94-84	Retainer Clip	366	580 62 62-02	Bracket Reinforcement
161	532 10 57-09	Spring, Return, Clutch			
163	532 40 72-46	Rod Pedal Control			
166	532 42 91-64	Nut Push .625			

NOTE: All component dimensions given in U.S. inches
1 inch = 25.4 mm

**TRACTOR - MODEL NO. TS 354XD (96043030500), PRODUCT NO. 960 43 03-05
ENGINE**

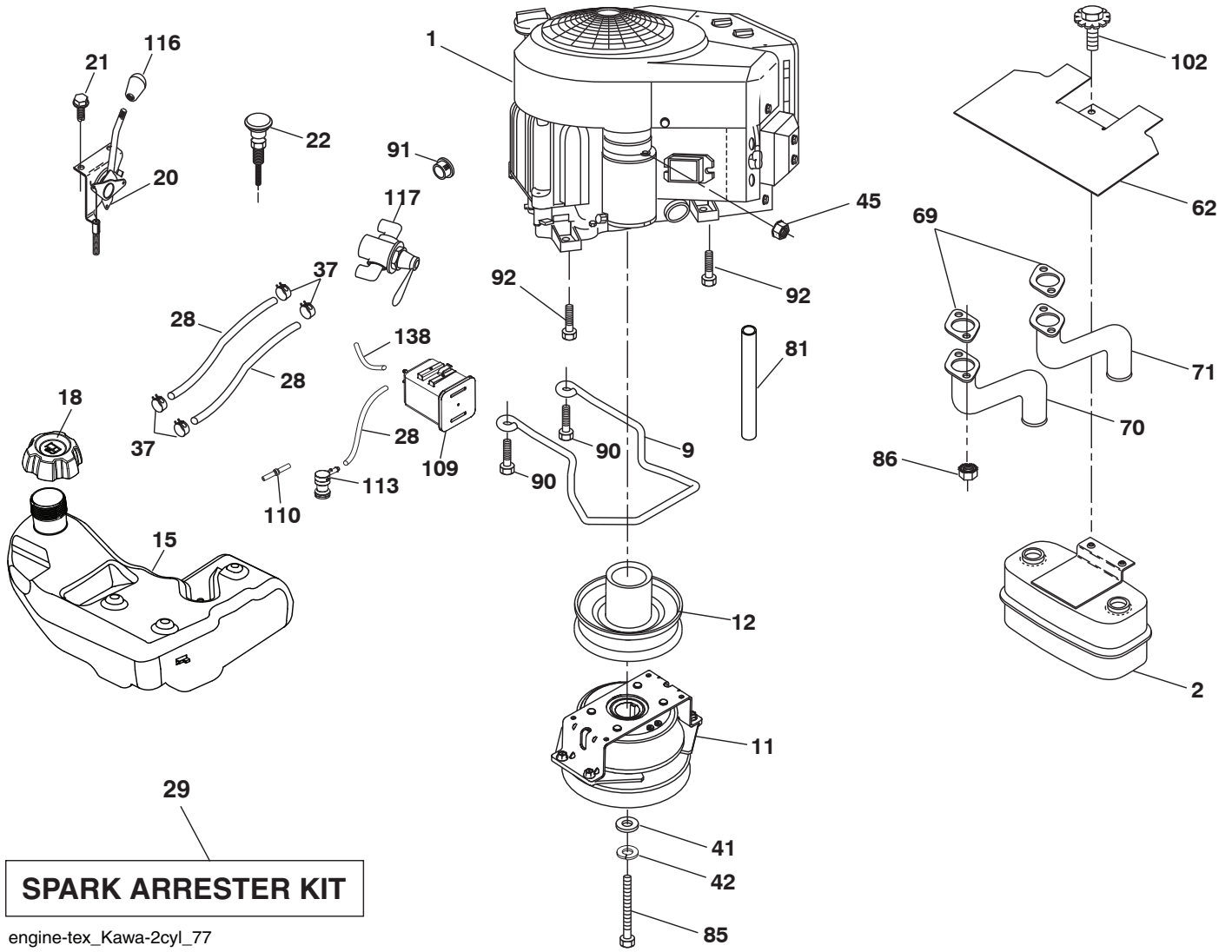

**TRACTOR - MODEL NO. TS 354XD (96043030500), PRODUCT NO. 960 43 03-05
ENGINE**

KEY NO.	PART NO.	DESCRIPTION
1	---	Engine KAWA Model No. FR730V-ES04 (445363) (Order parts from engine manufacturer.)
2	589 81 87-01	Muffler
9	501 83 26-02	Keeper Asm. Belt Engine
11	587 24 14-01	Clutch OGURA
12	532 19 43-43	Pulley Engine
15	532 42 29-03	Tank Fuel
18	585 12 48-03	Cap Asm
20	532 42 43-41	Control Throttle
21	532 41 63-58	Screw #10 x 0.750 BOS Thread
22	532 18 95-41	Control Valve
28	532 40 11-35	Fuel Line
29	532 13 71-80	Spark Arrester Kit
37	532 12 34-87	Clamp Hose
41	532 12 61-97	Washer 1-1/2 OD x 15/32 ID x .250
42	539 99 02-47	Washer 7/16
45	873 51 04-00	Nut Keps Hex 1/4-20 unc
62	532 43 40-17	Shield Heat Muffler
69	532 17 81-51	Gasket
70	583 95 56-01	Tube Exhaust LH
71	583 95 57-01	Tube Exhaust RH
81	532 14 84-56	Oil Tube Drain
85	501 60 69-01	Bolt 7/16-20 x 3.0 x Gr. 5
86	532 18 43-62	Nut. Hex.Flange
90	817 00 06-16	Screw 3/8-16 x 1
91	532 18 74-95	Bushing
92	817 12 06-16	Screw 3/8-16 x 1
102	817 00 05-12	Screw 5/16 x 3/4
109	532 41 41-14	Canister Carbon Filter
110	532 41 41-18	Valve Asm, Anti-Slosh
113	532 41 41-27	Valve Start
116	539 13 26-24	Knob Soft Touch
117	532 42 08-28	Valve Fuel Reserve
138	532 42 07-18	Purge Line

NOTE: All component dimensions given in U.S. inches
1 inch = 25.4 mm

For engine service and replacement parts, call the toll free number for your engine manufacturer listed below:

Kawasaki 1-949-460-5688

TRACTOR - MODEL NO. TS 354XD (96043030500), PRODUCT NO. 960 43 03-05
STEERING ASSEMBLY

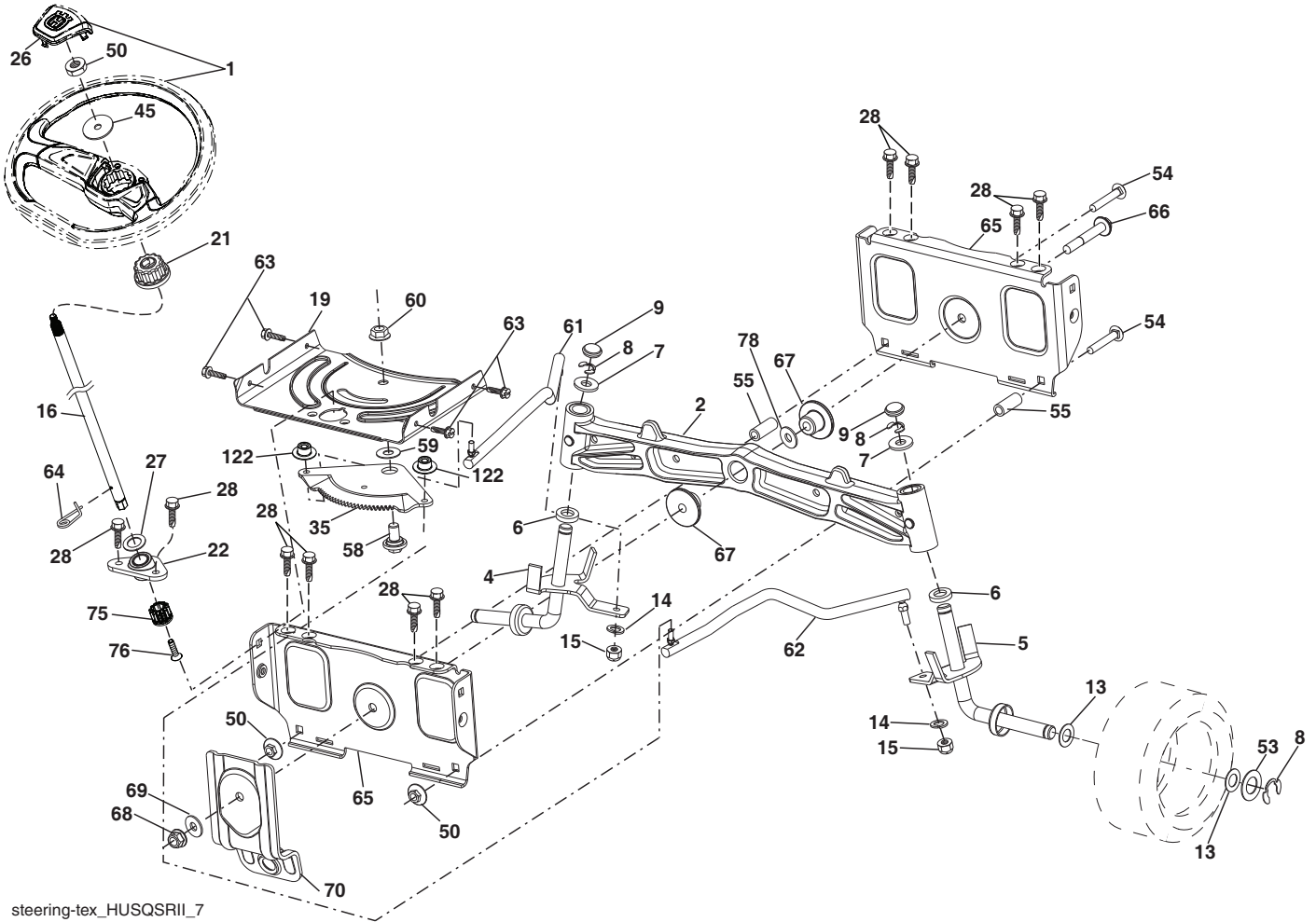

steering-tex_HUSQSR11_7

**TRACTOR - MODEL NO. TS 354XD (96043030500), PRODUCT NO. 960 43 03-05
STEERING ASSEMBLY**

KEY PART NO.	PART NO.	DESCRIPTION
1	597 86 61-01	Wheel, Steering, Kit (Includes Steering Cap)
2	532 19 59-68	Axle Asm., Front
4	532 40 30-89	Spindle Asm. LH
5	532 40 30-90	Spindle Asm. RH
6	532 00 62-66	Washer, Thrust .75 x 1.230
7	532 12 17-48	Washer 25/32 x 1-5/8 x 16 Ga.
8	812 00 00-29	Ring, Clip #T5304-75
9	532 12 12-32	Cap, Spindle
13	532 12 17-49	Washer 25/32 x 1-1/4 x 16 Ga.
14	539 99 01-18	Washer 3/8
15	873 54 06-00	Nut, Crown Lock 3/8-24 unf
16	587 01 60-02	Steering Shaft
19	532 19 47-29	Plate Steering
21	586 84 02-01	Adapter Wheel Steering
22	585 02 99-01	Bearing
26	594 94 91-01	Wheel Steering, Cap
27	819 21 16-16	Washer
28	817 00 06-12	Screw 3/8-16 x 3/4
35	532 19 47-32	Gear, Sector Plate
45	587 01 64-01	Washer 3/8 ID 2-3/8 OD 12 Ga. PLTD
50	873 90 06-00	Nut Lock Flg 3/8-16 unc
53	532 18 89-67	Washer Hardened .793 x 1.637 x .060
54	874 76 06-36	Bolt Hex 3/8-16 unc x 2-1/4
55	532 41 47-36	Bolt Hex 3/8-16 unc x 2-1/4
58	532 19 47-47	Bolt Shoulder Sector Pivot CFM
59	532 19 47-48	Washer Thrust Sector Steering
60	873 97 10-00	Nut Flange Lock 5/8-11
61	588 79 44-02	Draglink, LH
62	588 79 45-02	Draglink, RH
63	817 00 05-12	Screw 5/16-18 x 3/4
64	532 19 98-49	Retainer Clip Spring Steering
65	532 19 47-34	Brace Axle Front
66	871 02 07-48	Bolt Hex Fghd 7/16-14 x 3 Serr
67	532 19 47-37	Bushing PM Front Axle
68	873 90 07-00	Nut Lock Flange 7/16-14 Gr. 5
69	532 19 91-62	Washer 1.5 x .505 x .118
70	585 33 88-01	Bracket Deck Susp. Front
75	580 68 37-01	Pinion
76	580 68 36-01	Screw Head Sock
78	532 05 70-79	Washer Thrust
122	532 44 49-62	Cap Gear Sector

NOTE: All component dimensions given in U.S. inches
1 inch = 25.4 mm

**TRACTOR - MODEL NO. TS 354XD (96043030500), PRODUCT NO. 960 43 03-05
MOWER DECK**

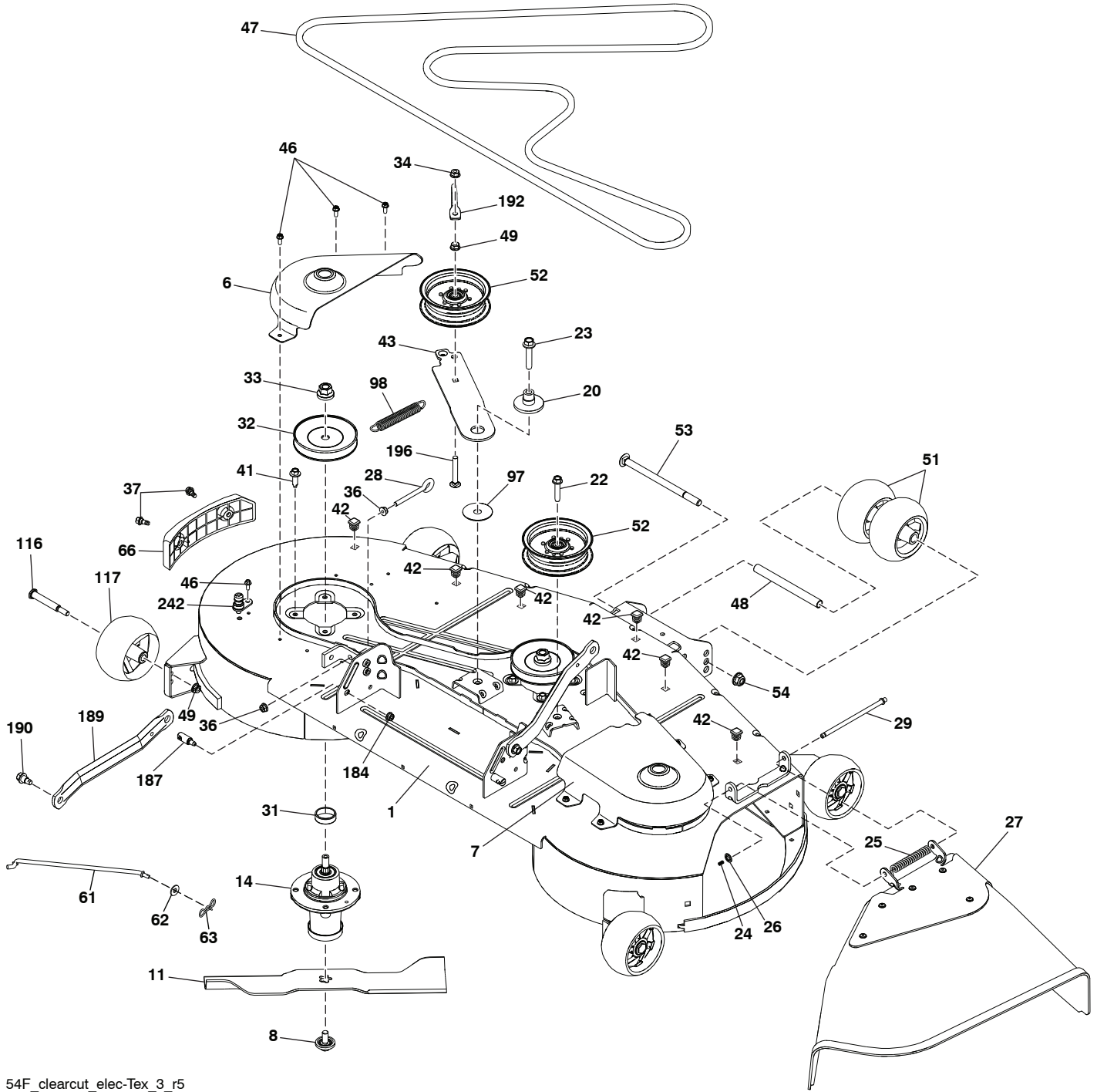

54F_clearcut_elec-Tex_3_r5

**TRACTOR - MODEL NO. TS 354XD (96043030500), PRODUCT NO. 960 43 03-05
MOWER DECK**

KEY NO.	PART NO.	DESCRIPTION	KEY NO.	PART NO.	DESCRIPTION
1	592 61 88-01	Kit SVC Weldment	48	574 19 65-01	Tube Roller
6	590 30 43-03	Cover Mandrel LH	49	873 90 06-00	Nut, Lock Flg. 3/8-16 unc
7	590 30 42-03	Cover Mandrel RH	51	574 16 96-01	Roller Guage
8	532 19 30-03	Bolt/Washer Am 7/16-20	52	532 19 73-79	Pulley Idler 4.50
11	582 76 05-08	Blade 54cc	53	872 14 08-64	RHSNB 1/2-13 x 8 Gr. 5 ZD
14	539 13 18-98	Housing, Mandrel	54	521 99 11-01	Nut 1/2-13 Hex Flg Nyloc ZD
20	532 19 72-36	Spacer Idler Pulley	61	532 40 03-37	Rod Anti-Sway
22	817 49 06-28	Screw THDROL 3/8-16 x 1-3/4	62	819 13 13-12	Washer 13/32 x 13/16 x 12 Ga.
23	588 43 83-01	Screw 7/16-14 x 2.125 Washer	63	532 19 42-08	Pin Cotter 5/16 Bow Tie Lock
24	532 10 53-04	Cap Sleeve	66	590 73 25-01	Bumper Asm 54cc
25	587 35 47-01	Spring, Torsion	97	532 17 85-15	Washer Hardened
26	532 11 04-52	Nut, Push	98	587 35 84-01	Spring Drive
27	590 63 22-01	Deflector Shield	116	532 19 34-06	Bolt, Shoulder
28	539 11 55-74	Bolt Eye 5/16 x 3-1/2	117	589 52 73-01	Gauge Wheel
29	532 13 14-91	Rod, Hinge	184	873 90 05-00	Nut Lock Hex Flange 5/16-18
31	532 18 76-90	Washer Spacer Mandrel	187	532 19 51-61	Stud Fastener w/"D" Anti-Rotation
32	532 15 35-35	Pulley, Mandrel	189	587 14 05-02	Arm Susp. Mower Rear
33	532 40 02-34	Nut, Flg. Top Lock	190	532 19 65-39	Bolt Shoulder
34	873 68 06-00	Nut Crownlock 3/8-16 unc	192	532 19 84-68	Keeper Belt Idler
36	539 99 05-85	Nut 5/16-18 Hex	196	539 12 81-01	Bolt Carriage 3/8-16 unc x 2-1/2
37	532 17 01-65	Bolt Shoulder 5/16-18	242	532 41 55-98	Port Washout
41	584 95 39-01	Bolt Hex Wshr .313 - 18 x 1.19	--	532 41 64-05	Coupling Quick Connect
42	596 95 22-01	Plug Hole	--	592 61 89-01	Replacement Mower, Complete
43	582 21 96-02	Arm, Idler			
46	532 13 77-29	Screw, Thd. roll. 1/4-20 x 5/8			
47	582 23 63-01	V-Belt, Mower			

NOTE: All component dimensions given in U.S. inches
1 inch = 25.4 mm

**TRACTOR - MODEL NO. TS 354XD (96043030500), PRODUCT NO. 960 43 03-05
MOWER LIFT**

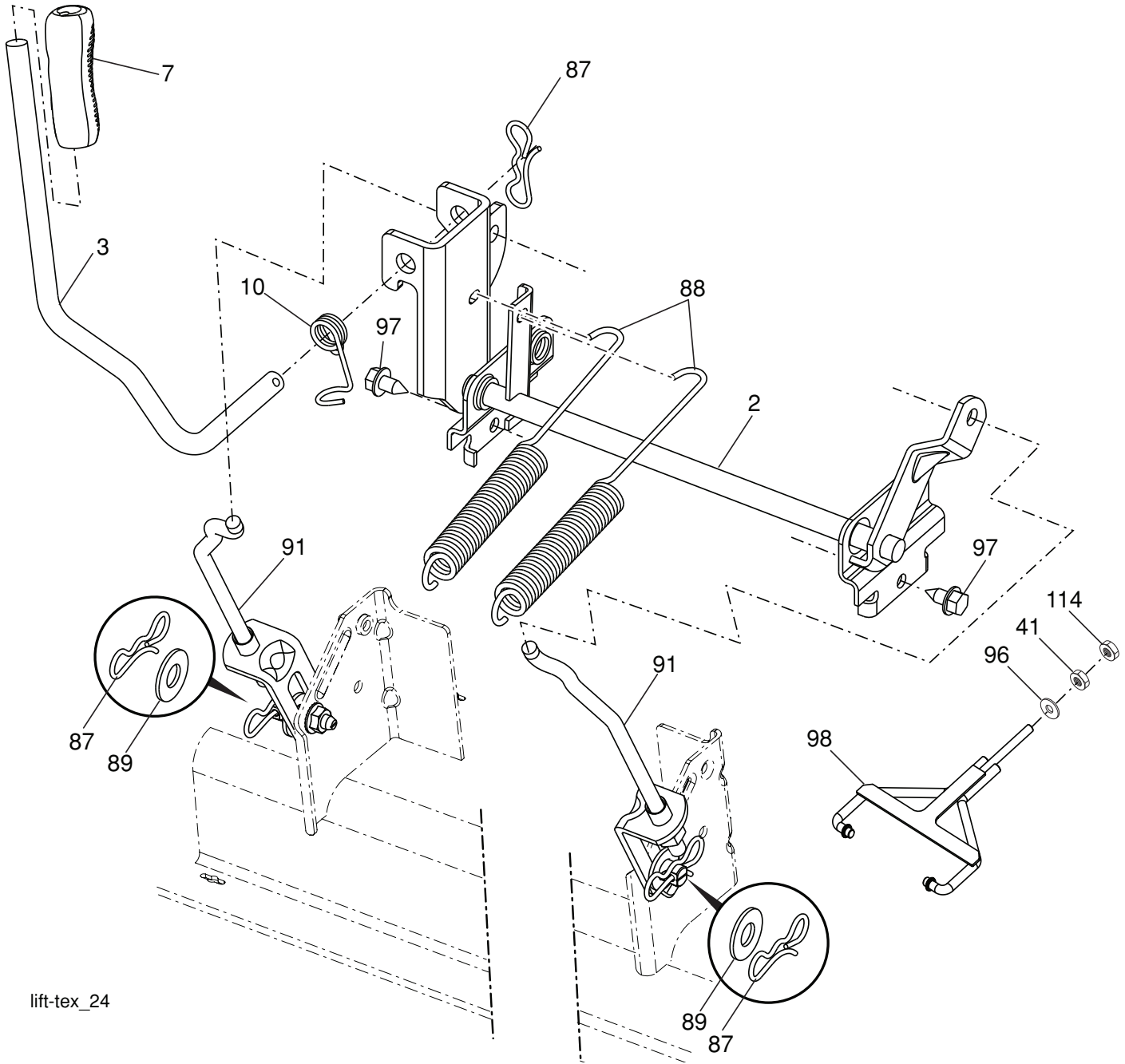

lift-tex_24

KEY NO.	PART NO.	DESCRIPTION
2	532 42 20-27	Shaft Asm., Lift
3	532 19 52-30	Lever Asm., Lift RH
7	580 96 23-01	Grip, Lever
10	532 19 63-14	Spring Torsion
41	532 17 59-94	Nut Lift Link
87	532 19 42-09	Pin Cotter 7/16 Bow Tie Lock
88	532 19 53-04	Spring Lift Assist
89	819 19 19-12	Washer Clear Zinc

KEY NO.	PART NO.	DESCRIPTION
91	532 40 34-07	Link Lift Susp Mower Rear
96	532 19 52-63	Bushing Spherical
97	817 00 06-12	Screw 3/8-16 x .75
98	589 31 87-03	Link Lift Susp. Front Mower
114	873 36 07-00	Nut Jam 7/16-20

NOTE: All component dimensions given in U.S. inches
1 inch = 25.4 mm

TRACTOR - MODEL NO. TS 354XD (96043030500), PRODUCT NO. 960 43 03-05 SEAT ASSEMBLY

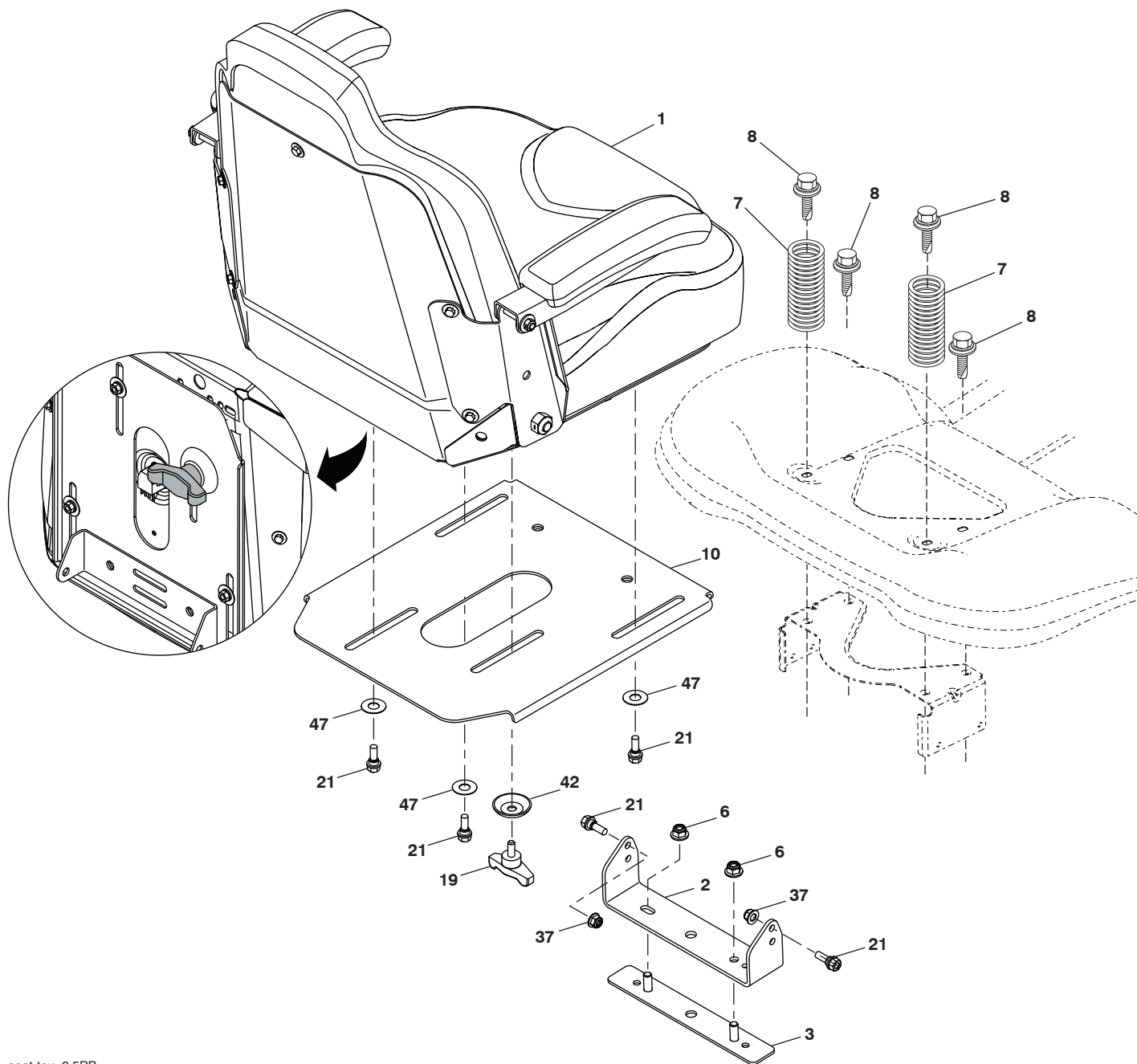

seat-tex_6.5PB

KEY NO.	PART NO.	DESCRIPTION
1	590 33 73-01	Seat
2	590 33 66-02	Bracket Pivot Fender
3	590 77 76-02	Brkt, Asm Fender
6	521 99 65-01	Nut 3/8-16 Hex Fig Nyloc
7	590 81 23-01	Spring, Seat Cprsn
8	532 17 18-77	Bolt 5/16-18 unc x 3/4 w/Sems
10	590 48 17-02	Seat, Plate, Brkt.
19	590 69 15-01	Knob Seat 5/16-18 x 3/4

KEY NO.	PART NO.	DESCRIPTION
21	532 16 96-12	Bolt, Shoulder 5/16-18
37	539 11 28-99	Nut, Hex 5/16-18 unc
42	532 19 93-71	Washer Cup
47	590 35 11-01	Washer Nylon 50 x 1.12 x 003

NOTE: All component dimensions given in U.S. inches
1 inch = 25.4 mm

**TRACTOR - MODEL NO. TS 354XD (96043030500), PRODUCT NO. 960 43 03-05
DECALS**

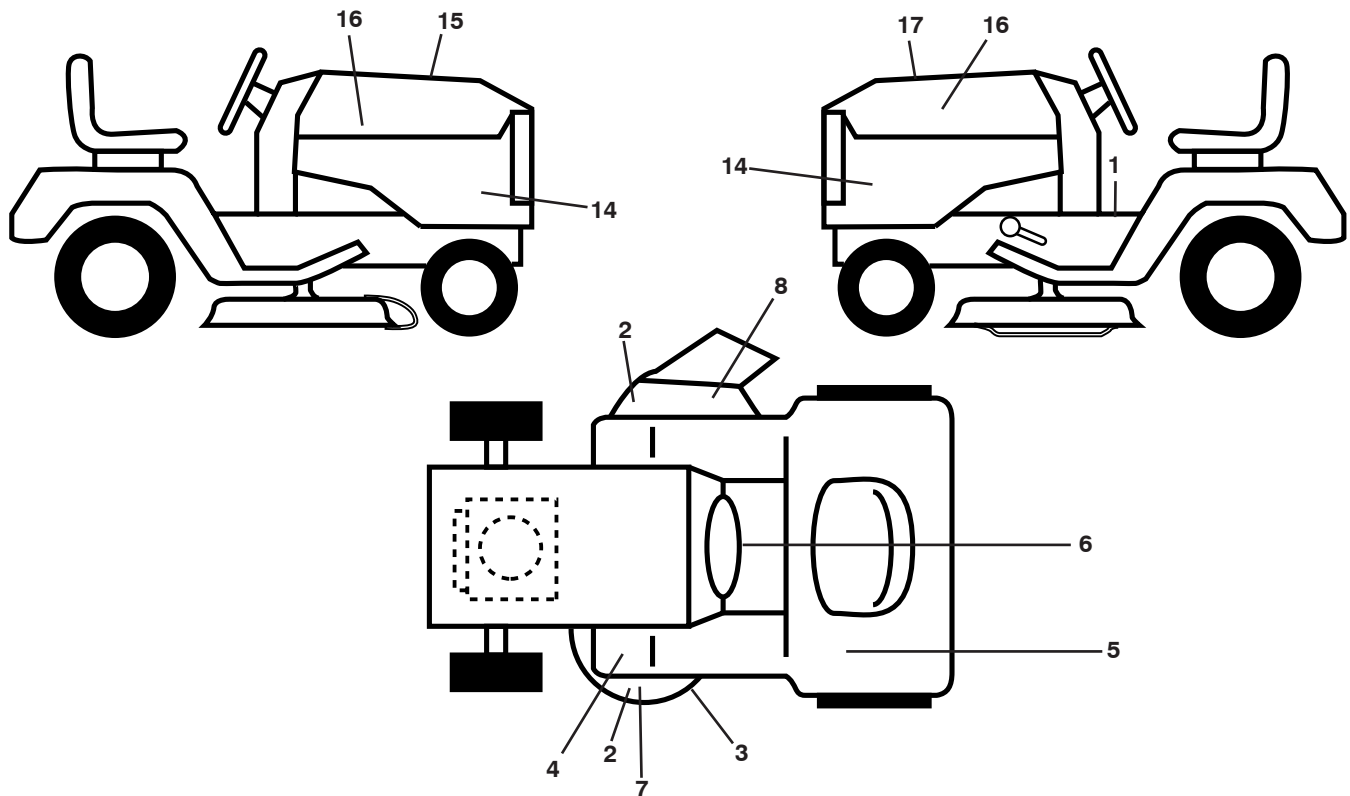

KEY NO.	PART NO.	DESCRIPTION
1	581 57 89-01	Decal, Warning
2	589 35 79-01	Decal, No Step
3	592 89 83-01	Decal, Deck Warn
4	591 16 47-01	Decal, Deck Belt Routing
5	597 47 01-01	Decal, Reserve Fuel
6	596 02 42-01	Decal, Warning
7	593 80 88-01	Decal, Deck 54 CC
8	586 97 88-01	Decal, Deflect. Warning
14	591 44 87-01	Decal, Panel Side

KEY NO.	PART NO.	DESCRIPTION
15	532 42 38-29	Decal, Cust. Resp.
16	581 62 73-01	Decal, Hood Logo
17	590 93 74-01	Decal, Replacement
--	581 72 48-01	Decal, Bypass
--	532 43 98-82	Pad, Footrest, LH
--	532 43 98-81	Pad, Footrest, RH
--	114 19 11-49	Manual, Operator's (English/Spanish)
--	114 19 18-27	Manual, Part's (English/Spanish)
--	587 71 00-26	Manual, QSG Husq (English/Spanish)

WHEELS AND TIRES

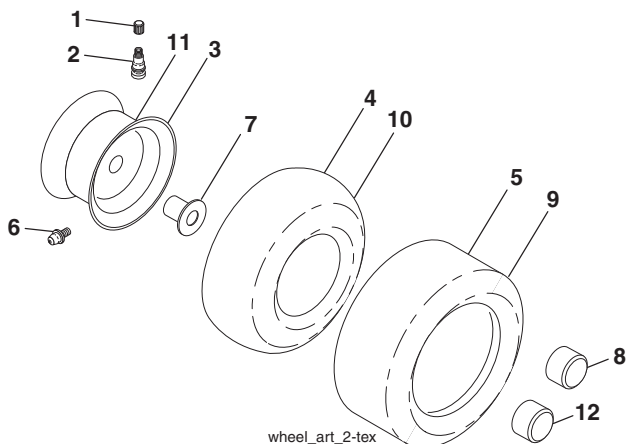

KEY NO.	PART NO.	DESCRIPTION
1	532 05 91-92	Cap, Valve, Tire
2	532 06 51-39	Stem, Valve
3	532 18 18-39	Rim Assembly, Front
4	532 00 81-34	Tube, Front (Service Item Only)
5	593 14 51-01	Tire, Front 16 x 6.5-8
6	532 00 02-78	Fitting, Grease (Front Wheel Only)
7	532 00 90-40	Bearing, Flange (Front Wheel Only)
8	532 17 50-39	Cap, Axle, Front
9	593 14 52-01	Tire, Rear 23 x 10.5-12
10	532 00 71-54	Tube, Rear (Service Item Only)
11	593 14 48-01	Rim Assembly, Rear
12	501 50 31-01	Cap, Hub, GT, PM, Black, Rear
--	532 14 43-34	Sealant, Tire (10 oz. Tube)

NOTE: All component dimensions given in U.S. inches
1 inch = 25.4 mm

NOTES

COMO UTILIZAR ESTE MANUAL

Este manual está diseñado para brindarle al comprador un medio para identificar las piezas del tractor para cuando necesite hacer el pedido de un repuesto. Las ilustraciones pueden o no representar los ensambles reales; por lo tanto, no se recomienda utilizar este manual como una guía para ensamblar o desarmar el tractor. Algunos accesorios y piezas están dibujados en tamaños más grandes para identificarlos con mayor facilidad.

Cada tractor tiene su propio número de modelo. El número de modelo del tractor se encuentra en el guardabarros debajo del asiento.

Soporte / Ayuda

Si necesita asistencia o tiene alguna pregunta acerca de la aplicación, operación, mantenimiento o piezas de su producto:

- Visite nuestro sitio web: www.husqvarna.com
- Llámenos de manera gratuita al: 1-800-487-5951

Cuando haga el pedido de una pieza, siempre brinde la siguiente información:

- Producto: "TRACTOR"
- NÚMERO DE MODELO: "TS 354XD" (96043030500)"
- Número de pieza
- Descripción de la pieza

ÍNDICE

DIAGRAMA.....	21
DIAGRAMA ELÉCTRICO.....	22-23
CHASIS.....	24-25
TRANSMISIÓN.....	26-27
MOTOR.....	28-29
DIRECCIÓN.....	30-31
PLATAFORMA DE LA CORTADORA DE CÉSPED.....	32-33
ELEVACIÓN DE LA CORTADORA DE CÉSPED.....	34
ASIENTO.....	35
CALCOMANÍAS.....	36

TRACTOR MODELO NO. TS 354XD (96043030500), PRODUCTO NO. 960 43 03-05

DIAGRAMA

SCH27-s

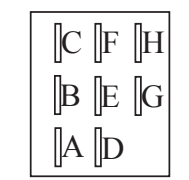
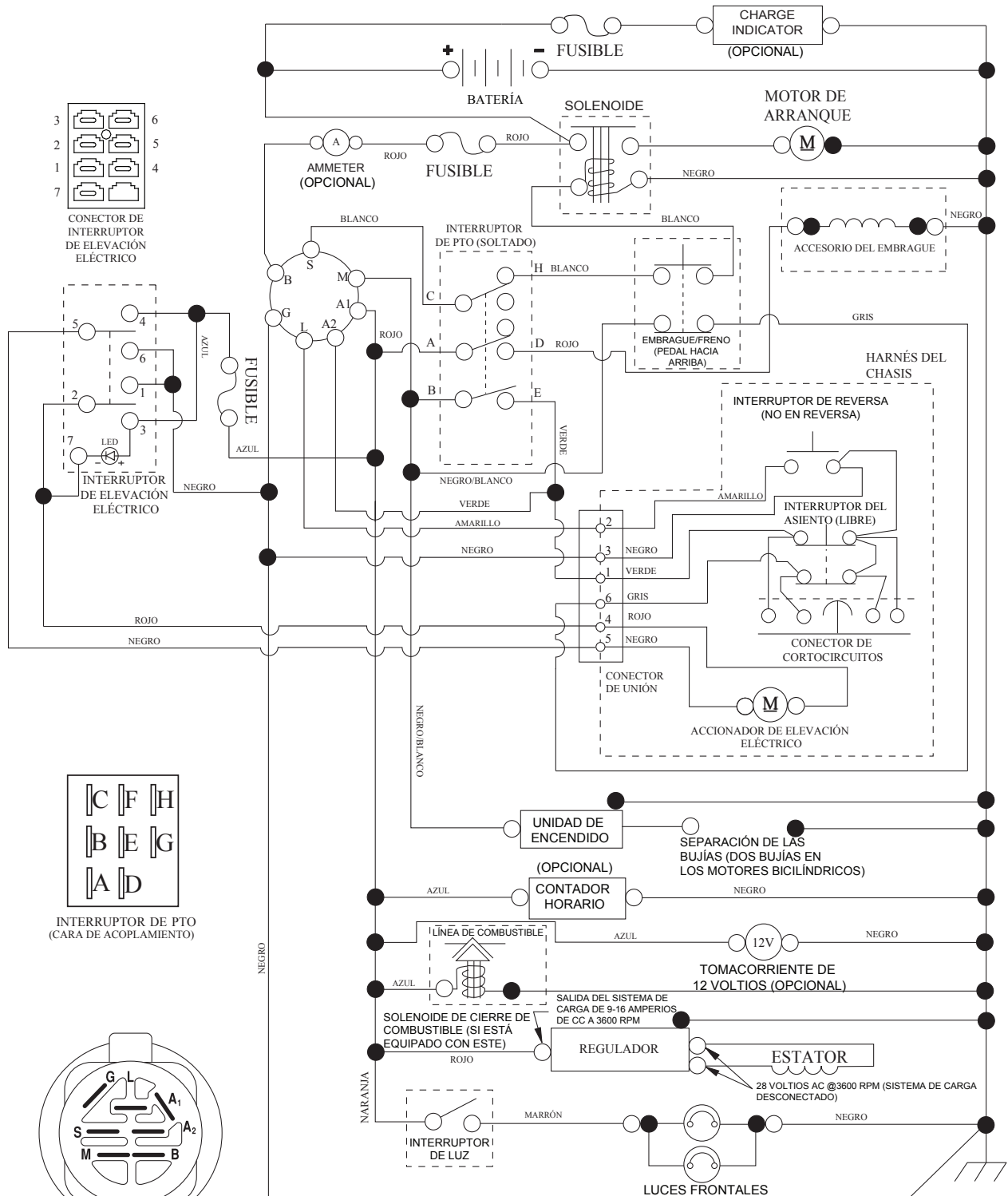

INTERRUPTOR DE PTO (CARA DE ACOPLAMIENTO)

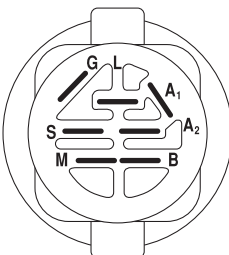

INTERRUPTOR DE ENCENDIDO

POSICIÓN	CIRCUITO «MARCA»
APAGADO	M+G+A1
PONER EN FUNCIONAMIENTO/ANULAR	B+A1
PONER EN FUNCIONAMIENTO	B+A1 L+A2
ARRANCAR	B + S + A1

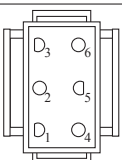

CONEXIÓN DEL ARNÉS DEL CHASIS (LATERAL QUE COINCIDA)

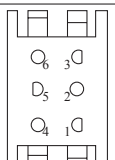

CONEXIÓN PARA EL ARNÉS DEL TABLERO (LATERAL QUE COINCIDA)

NOTA SOBRE LAS ABRAZADERAS DE AISLAMIENTO DEL CABLEADO: SI SE QUITAN LAS ABRAZADERAS DE AISLAMIENTO DEL CABLEADO PARA HACER EL MANTENIMIENTO DE LA UNIDAD, SE LAS DEBERÁ INSTALAR NUEVAMENTE PARA PROTEGER EL CABLEADO ADECUADAMENTE.

● CONEXIONES NO DESMONTABLES

○ CONEXIONES DESMONTABLES

TRACTOR MODELO NO. TS 354XD (96043030500), PRODUCTO NO. 960 43 03-05

DIAGRAMA ELÉCTRICO

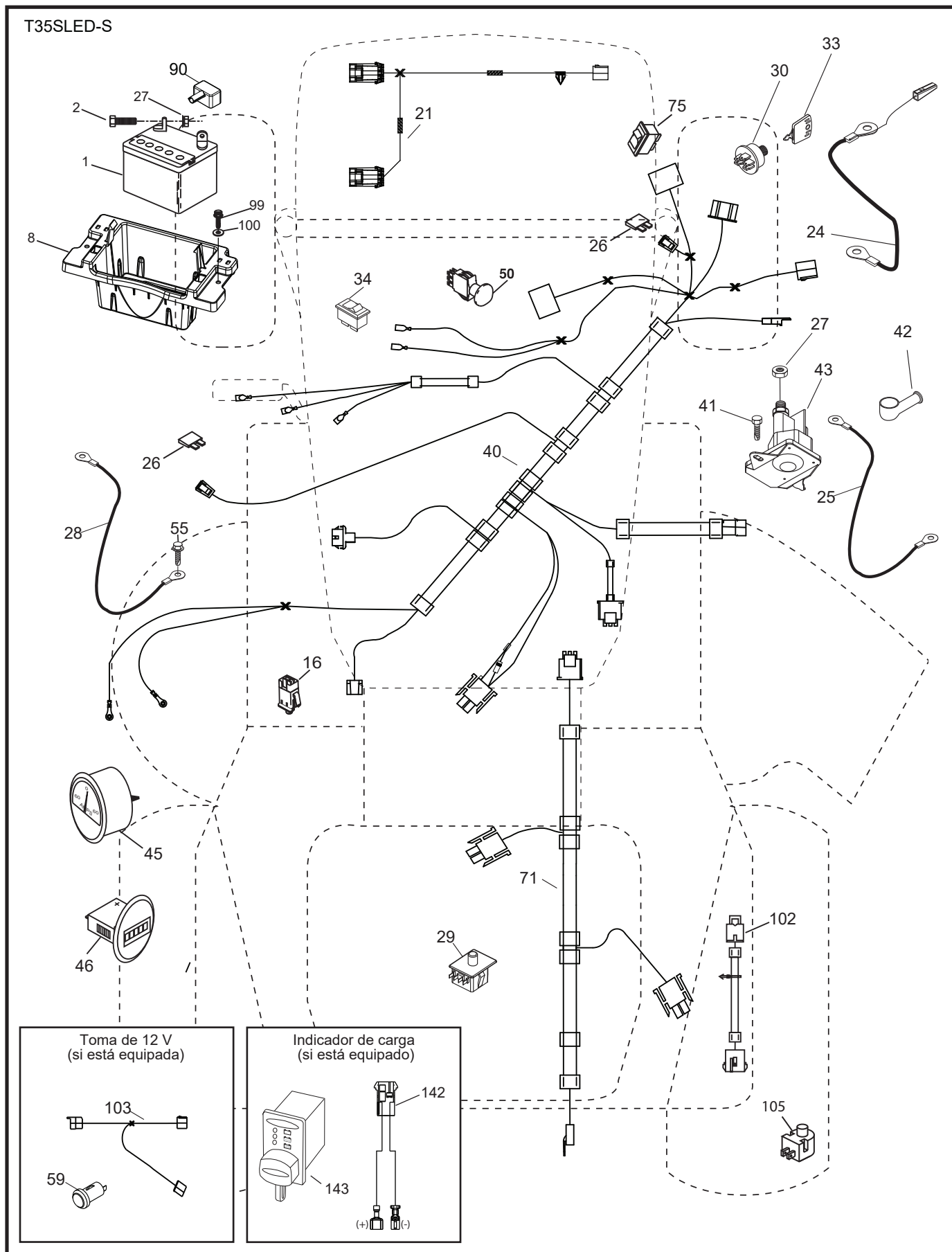

TRACTOR MODELO NO. TS 354XD (96043030500), PRODUCTO NO. 960 43 03-05
DIAGRAMA ELÉCTRICO

CÓDIGO No.	PIEZA No.	DESCRIPCIÓN
1	532 16 34-65	Batería
2	874 76 04-12	Perno de cabeza hexagonal de 1/4-20 x 3/4
8	532 41 41-26	Bandeja de batería
16	532 17 61-38	Interruptor corta corriente a presión
21	585 43 64-01	Cableado del enchufe para la luz
24	585 55 56-01	Cable
25	585 55 55-01	Cable
26	532 17 51-58	Fusible
27	873 51 04-00	Tuerca hexagonal Keps de 1/4-20 unc
28	532 41 65-88	Cable a tierra
29	532 19 27-49	Interruptor del asiento
30	532 19 33-50	Interruptor de encendido
33	532 41 19-35	Llave/cadena
34	532 11 07-12	Interruptor de luz/de restauración
40	501 13 36-01	Cableado de encendido
41	817 72 04-08	Tornillo
42	532 13 15-63	Cubierta de la terminal
43	582 04 28-01	Solenoides
45	587 55 39-03	Amperímetro
46	587 55 40-03	Con contador horario
50	582 10 76-02	Interruptor PTO
55	817 06 05-12	Tornillo de 5/16-18 x 3/4
59	532 40 03-03	Salida de 12 voltios
71	580 51 30-01	Cableado de encendido, chasis
75	580 36 64-01	Encienda / apague el bloqueo diferencial
90	532 43 53-95	Tapa de los bornes de la batería
99	817 67 04-12	Tornillo 1/4-20 x 3/4
100	819 09 14-16	Arandela
102	532 40 44-54	Arnés coleta K46 ROS
103	532 42 17-47	Arnés coleta
105	532 40 75-68	Cambiar el reverso

NOTA: Las dimensiones de todos los componentes están expresadas en pulgadas americanas. 1 pulgada = 25,4 mm

TRACTOR MODELO NO. TS 354XD (96043030500), PRODUCTO NO. 960 43 03-05
CHASIS

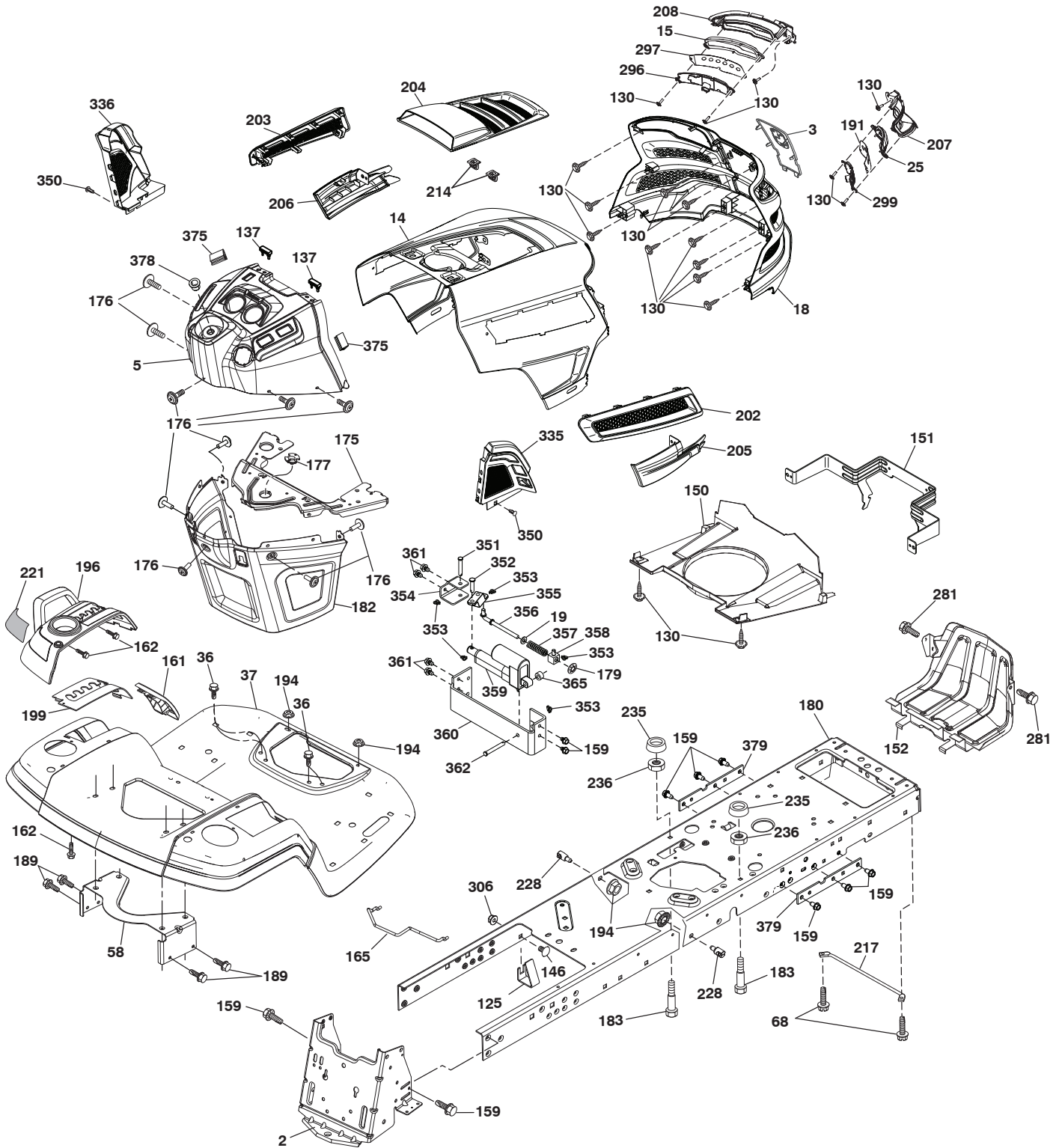

chassis-tex_GT HUSQ_II_261

**TRACTOR MODELO NO. TS 354XD (96043030500), PRODUCTO NO. 960 43 03-05
CHASIS**

CÓDIGO No.	PIEZA No.	DESCRIPCIÓN	CÓDIGO No.	PIEZA No.	DESCRIPCIÓN
2	580 43 44-01	Barra de tracción	206	532 43 97-29	Camisa de Capota (LI)
3	532 44 44-81	Aplica Submontaje	207	585 42 00-02	Bisel derecho
5	590 74 88-19	Tablero	208	585 42 01-02	Bisel izquierdo
14	532 44 11-77	Capota	214	532 19 91-45	Cierre
15	585 42 03-01	Lente izquierdo de la parrilla	217	532 40 91-67	Varilla giratoria
18	587 52 34-01	Parrilla	218	532 19 63-95	Tope
19	819 13 13-12	Tornillo 13/32 x 13/16 x 12	221	532 19 89-09	Reflector (LI)
25	585 42 02-01	Lente derecho de la parrilla	228	532 19 51-61	Sujetador del travesaño
36	817 06 05-12	Tornillo de 5/16-18 x 3/4	235	532 40 61-29	Separador del guardabarros
37	532 44 12-08	Guardabarros	236	873 93 05-00	Tuerca de presión 5/16-18 unc
58	532 19 43-14	Soporte de Guardabarros	281	817 00 06-16	Perno 3/8-16 x 1
68	539 99 08-58	Tornillo de 5/16-18 x 1/2	296	585 42 05-01	Luz LED (LD)
125	581 68 48-01	Soporte	297	586 18 29-01	Parte móvil reflexivo (LI)
130	532 41 63-58	Tornillo No. 10 x 0,75	299	585 42 04-01	Luz LED (LI)
137	532 40 75-90	Cubierta Tablero	306	873 90 06-00	Tuerca
146	581 85 79-01	Perno	335	532 44 82-04	Cubierta (LD)
150	532 43 97-74	Cubierta	336	532 44 53-09	Cubierta (LI)
151	532 43 66-70	Soporte de Capota	350	532 44 51-43	Cierre del árbol de navidad
152	532 43 98-70	Protector contra oscurecimiento	351	532 42 17-34	Clavija de horquilla .375 x 2.125
159	817 00 06-12	Tornillo 3/8-16 x 3/4	352	532 44 86-34	Clavija .375 x 2.125
161	532 43 99-29	Ventana de combustible	353	532 17 80-62	Pinzas de retención .0375
162	532 14 24-32	Tornillo	354	532 44 86-19	Soporte
165	532 19 43-30	Soporte de Tanque de Gasolina	355	532 44 86-36	Mecanismo
175	590 60 77-02	Travesaño	356	532 44 86-93	Acoplamiento
176	532 40 07-76	Tornillo de 10-24 x 5/8	357	532 44 86-84	Resorte
177	532 19 52-28	Buje de dirección	358	580 36 66-01	Guía
179	532 16 89-37	Tuerca de presión	359	584 39 34-01	Accionador
180	593 34 63-01	Chasis	360	532 44 86-18	Soporte del accionador
182	532 40 68-59	Tablero inferior	361	817 49 06-10	Tornillo 3/8-16 x 5/8
183	874 52 05-20	Perno 5/16-18 x 1-1/4	362	532 44 86-33	Clavija .375 x 2.42
189	817 00 05-12	Tornillo	365	532 44 73-68	Separador .375 x .4375L
191	586 18 28-01	Parte móvil reflexivo (LD)	375	586 90 82-01	Cubierta Capota
194	873 90 05-00	Tuerca de presión de 5/16-18	378	590 84 98-01	Buje
196	532 43 96-74	Ensamble de la consola de la plata- forma de elevación	379	593 20 69-02	Refuerzo de la placa del chasis
199	532 19 82-59	Chapa	--	532 43 18-82	Parachoque
202	532 43 97-28	Salida de Ventilación (LD)			
203	532 43 97-27	Salida de Ventilación (LI)			
204	532 43 57-14	Salida de Ventilación superior			
205	532 43 97-30	Camisa de Capota (LD)			

NOTA: Las dimensiones de todos los componentes están expresadas en pulgadas americanas. 1 pulgada = 25,4 mm

TRACTOR MODELO NO. TS 354XD (96043030500), PRODUCTO NO. 960 43 03-05
TRANSMISIÓN

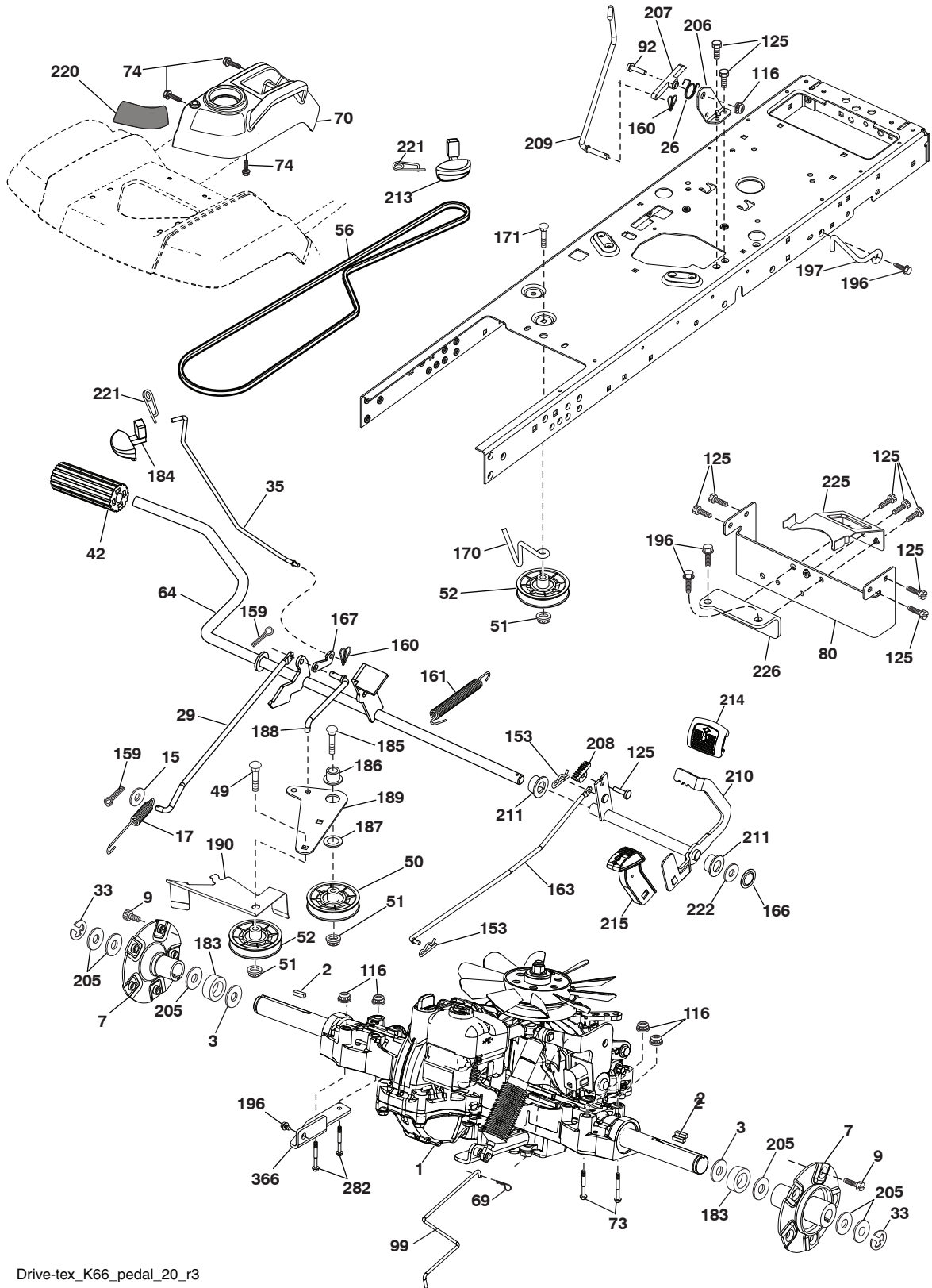

Drive-tex_K66_pedal_20_r3

TRACTOR MODELO NO. TS 354XD (96043030500), PRODUCTO NO. 960 43 03-05

TRANSMISIÓN

CÓDIGO No.	PIEZA No.	DESCRIPCIÓN	CÓDIGO No.	PIEZA No.	DESCRIPCIÓN
1	-----	Transeje, Tufftorq K66ELD (580402201) (Haga el pedido de las piezas al fabricante del transeje.)	171	872 11 06-16	Perno 3/8-16 unc x 2
			183	587 58 74-01	Separador del eje
			184	587 65 37-01	Manija del freno de mano
			185	872 11 06-22	Perno 3/8-16 unc x 2-3/4 Gr 5
2	539 91 27-57	Cuña .25 x 1.25	186	532 19 43-21	Espaciador de retención
3	532 00 75-63	Arandela	187	819 13 32-10	Arandela
7	586 93 54-02	Rueda eje la asamblea	188	582 21 70-01	Mecanismo de desplazamiento de la varilla de mando del embrague del largo
9	532 14 00-80	Perno			
15	819 13 13-16	Arandela 13/32 x 13/16 x Calibre 16			
17	532 40 10-72	Resorte de freno	189	532 19 43-17	Palanca acodada del mecanismo de desplazamiento
26	532 19 96-79	Crucero con retorno de muelle			
29	532 40 72-45	Varilla del freno	190	532 19 43-18	Sujetador de la palanca acodada del mecanismo de desplazamiento
33	812 00 00-53	Aro "E"			
35	590 60 59-02	Varilla del freno de mano	196	817 00 06-16	Tornillo 3/8-16 x 1
42	532 00 88-83	Cubierta del pedal	197	585 65 86-01	Support embrayage anti-rotation
49	872 11 06-14	Perno	205	532 12 38-00	Arandela 1-1/32 x 1-5/8 x Calibre 16
50	532 19 43-27	Polea loca plana	206	532 44 85-96	Soporte
51	873 90 06-00	Tuerca 3/8-16	207	587 03 14-01	Bloqueo del control del crucero
52	532 19 43-26	Polea loca con ranura en V con un desplazamiento	208	532 19 78-69	Engranaje del sector de control del crucero
56	592 85 53-01	Correa trapezoidal de la transmisión	209	590 52 78-02	Varilla de control del crucero
64	532 19 78-65	Ensamble del eje Control del pedal de freno	210	532 19 78-60	Ensamble del balancín del control del pedal
69	532 42 33-03	Pasador de cabello .059 x 1.125	211	532 12 01-83	Rodamiento de nylon
70	532 43 96-61	Ensamble del console	213	532 40 31-19	Perilla de control del crucero
73	874 49 05-44	Perno 5/16-18 x 3 Gr. 5	214	532 42 12-63	Forro del pedal para avanzar
74	532 14 24-32	Tornillo 1/4 x 1/2	215	586 60 65-02	Forro del pedal para retroceder
80	589 33 34-02	Correa de torsión	220	532 19 89-08	Reflector (LD)
92	874 76 05-20	Perno 5/16-18 x 1/2	221	532 40 31-87	Abrazadera de retención del resorte de la manija
99	582 40 47-01	Resorte			
116	873 90 05-00	Tuerca 5/16-18	222	879 21 20-10	Arandela 21/32 x 1-1/4 x Calibre 10
125	817 00 05-12	Tornillo 5/16-18 x 3/4	225	532 40 73-11	Sujetador de la correa
153	532 00 44-97	Retén del resorte	226	532 40 71-09	Soporte de montaje
159	876 02 04-12	Pasador de chaveta de 1/8 x 3/4	282	874 49 05-48	Perno 5/16-18 x 3.0 Gr 5
160	532 16 94-84	Abrazadera de retención	366	580 62 62-02	Soporte
161	532 10 57-09	Resorte de retorno del embrague			
163	532 40 72-46	Varilla de control del pedal			
166	532 42 91-64	Tuerca .625			
167	532 40 52-57	Pestillo del freno de mano			
170	532 19 43-22	Sujetador de la correa			

NOTA: Las dimensiones de todos los componentes están expresadas en pulgadas americanas. 1 pulgada = 25,4 mm

TRACTOR MODELO NO. TS 354XD (96043030500), PRODUCTO NO. 960 43 03-05
MOTOR

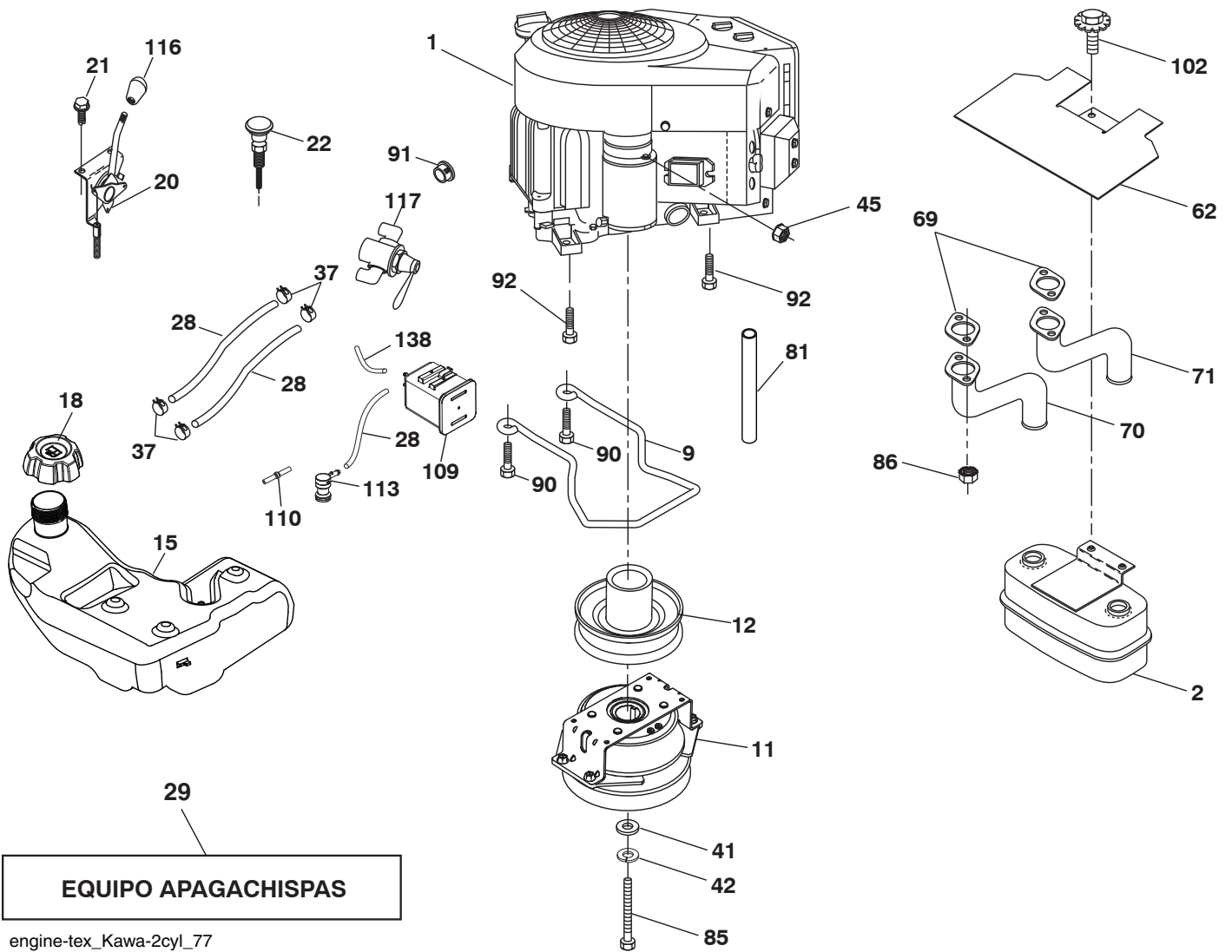

**TRACTOR MODELO NO. TS 354XD (96043030500), PRODUCTO NO. 960 43 03-05
MOTOR**

CÓDIGO No.	PIEZA No.	DESCRIPCIÓN
1	---	Motor KAWA modelo No. FR730V-ES04 (445363) (Haga el pedido de las piezas al fabricante del motor.)
2	589 81 87-01	Silenciador
9	501 83 26-02	Ensamble del sujetador de la correa del motor
11	587 24 14-01	Embrague de Ogura
12	532 19 43-43	Polea del motor
15	532 42 29-03	Tanque de Gasolina de 4,0 R
18	585 12 48-03	Tapa
20	532 42 43-41	Control del regulador
21	532 41 63-58	Tornillo No. 10 x 0,75 con rosca reforzada
22	532 18 95-41	Control del obturador
28	532 40 11-35	Línea de combustible
29	532 13 71-80	Equipo apagachispas
37	532 12 34-87	Abrazadera de la manguera
41	532 12 61-97	Arandela 1-1/2 x 15/32 x .250
42	539 99 02-47	Arandela de presión de 7/16
45	873 51 04-00	Tuerca
62	532 14 66-29	Silenciador con pantalla térmica
69	532 17 81-51	Junta
70	583 95 56-01	Tubo de escape izquierdo
71	583 95 57-01	Tubo de escape derecho
81	532 14 84-56	Tubo de drenaje
85	501 60 69-01	Perno de 7/16-20 x 3.0 x grado 5
86	532 18 43-62	Tuerca brida hexagonal
90	817 00 06-16	Tornillo de 3/8-16 x 1
91	532 18 74-95	Buje
92	817 12 06-16	Tornillo 3/8-16 x 1
102	817 00 05-12	Tornillo 5/16-18 x 3/4
109	532 41 41-14	Recipiente, filtro de carbón
110	532 41 41-18	Conjunto de válvula, anti-chapoteo
113	532 41 41-27	Válvula, arranque
116	539 13 26-24	Tacto suave de la perilla
117	532 42 08-28	Reserva de combustible valvular
138	532 42 07-18	Extensión del aceite

NOTA: Las dimensiones de todos los componentes están expresadas en pulgadas americanas. 1 pulgada = 25,4 mm

Para realizar el mantenimiento del motor y para obtener repuestos, llame al número gratuito del fabricante de su motor que se enumera a continuación:

Kawasaki 1-949-460-5688

TRACTOR MODELO NO. TS 354XD (96043030500), PRODUCTO NO. 960 43 03-05
ENSAMBLE DE LA DIRECCIÓN

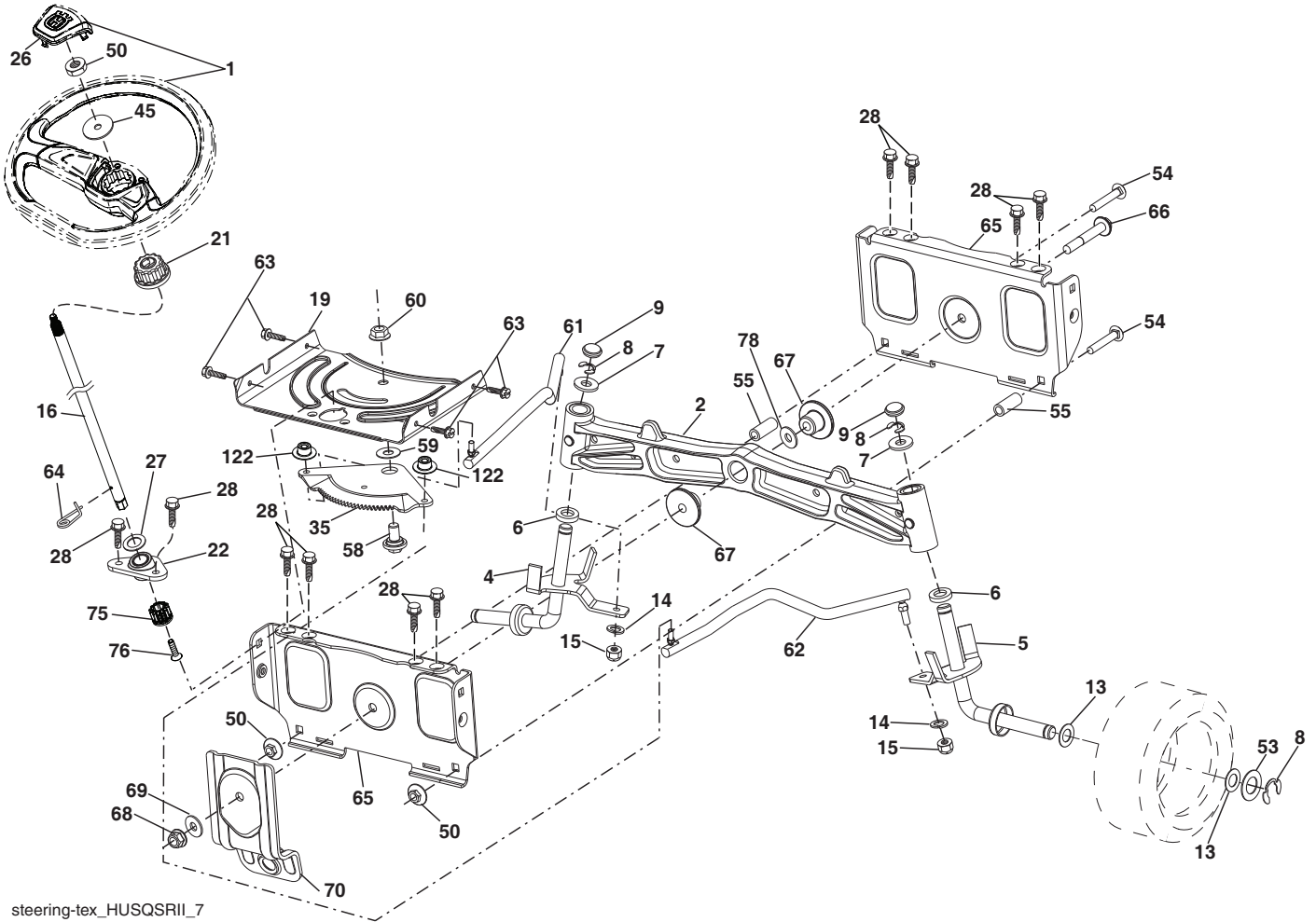

steering-tex_HUSQSR11_7

**TRACTOR MODELO NO. TS 354XD (96043030500), PRODUCTO NO. 960 43 03-05
ENSAMBLE DE LA DIRECCIÓN**

CÓDIGO No.	PIEZA No.	DESCRIPCIÓN
1	597 86 61-01	Kit, rueda, dirección (Incluye volante y tapa del volante)
2	532 19 59-68	Ensamble del eje delantero
4	532 40 30-89	Ensamble del husillo izquierdo
5	532 40 30-90	Ensamble del husillo derecho
6	532 00 62-66	Arandela de empuje de .75 x 1.230
7	532 12 17-48	Arandela de 25/32 x 1-5/8 calibre 16
8	812 00 00-29	Abrazadera del aro No. T5304-75
9	532 12 12-32	Tapa del husillo
13	532 12 17-49	Arandela de 25/32 x 1-1/4 calibre 16
14	539 99 01-18	Arandela 3/8
15	873 54 06-00	Tuerca de 3/8-24 unf
16	587 01 60-02	Eje de dirección
19	532 19 47-29	Placa de dirección
21	586 84 02-01	Adaptador del volante de dirección
22	585 02 99-01	Rodamiento
26	594 94 91-01	Inserto del volante de dirección
27	819 21 16-16	Arandela
28	817 00 06-12	Tornillo de 3/8-16 x 3/4
35	532 19 47-32	Engranaje del sector de la placa
45	587 01 64-01	Arandela 3/8 ID 2-3/8 OD calibre 12 PLTD
50	873 90 06-00	Tuerca 3/8-16 unc
53	532 18 89-67	Arandela reforzada de, 793 x 1,637 x 0,060
54	874 76 06-36	Tornillo 3/8-16 unc x 2-1/4
55	532 41 47-36	Tornillo 3/8-16 unc x 2-1/4
58	532 19 47-47	Perno de tope del sector del pivote CFM
59	532 19 47-48	Arandela de empuje del sector de dirección
60	873 97 10-00	Tuerca de 5/8-11
61	588 79 44-02	Barra de acoplamiento izquierda
62	588 79 45-02	Barra de acoplamiento derecha
63	817 00 05-12	Tornillo de 5/16-18 x 3/4
64	532 19 98-49	Abrazadera de retención del resorte de la dirección
65	532 19 47-34	Apoyo del árbol delantero
66	871 02 07-48	Perno de cabeza hexagonal con brida acanalada de 7/16-14 x 3
67	532 19 47-37	Buje PM del eje delantero
68	873 90 07-00	Tuerca de 7/16-14 grado 5
69	532 19 91-62	Arandela de 1,5 x 0,505 x 0,118
70	585 33 88-01	Soporte de la plataforma delantera
75	580 68 37-01	Piñón
76	580 68 36-01	Tornillo
78	532 05 70-79	Tuerca
122	532 44 49-62	Tapa

NOTA: Las dimensiones de todos los componentes están expresadas en pulgadas americanas. 1 pulgada = 25,4 mm

TRACTOR MODELO NO. TS 354XD (96043030500), PRODUCTO NO. 960 43 03-05
PLATAFORMA DE LA CORTADORA DE CÉSPED

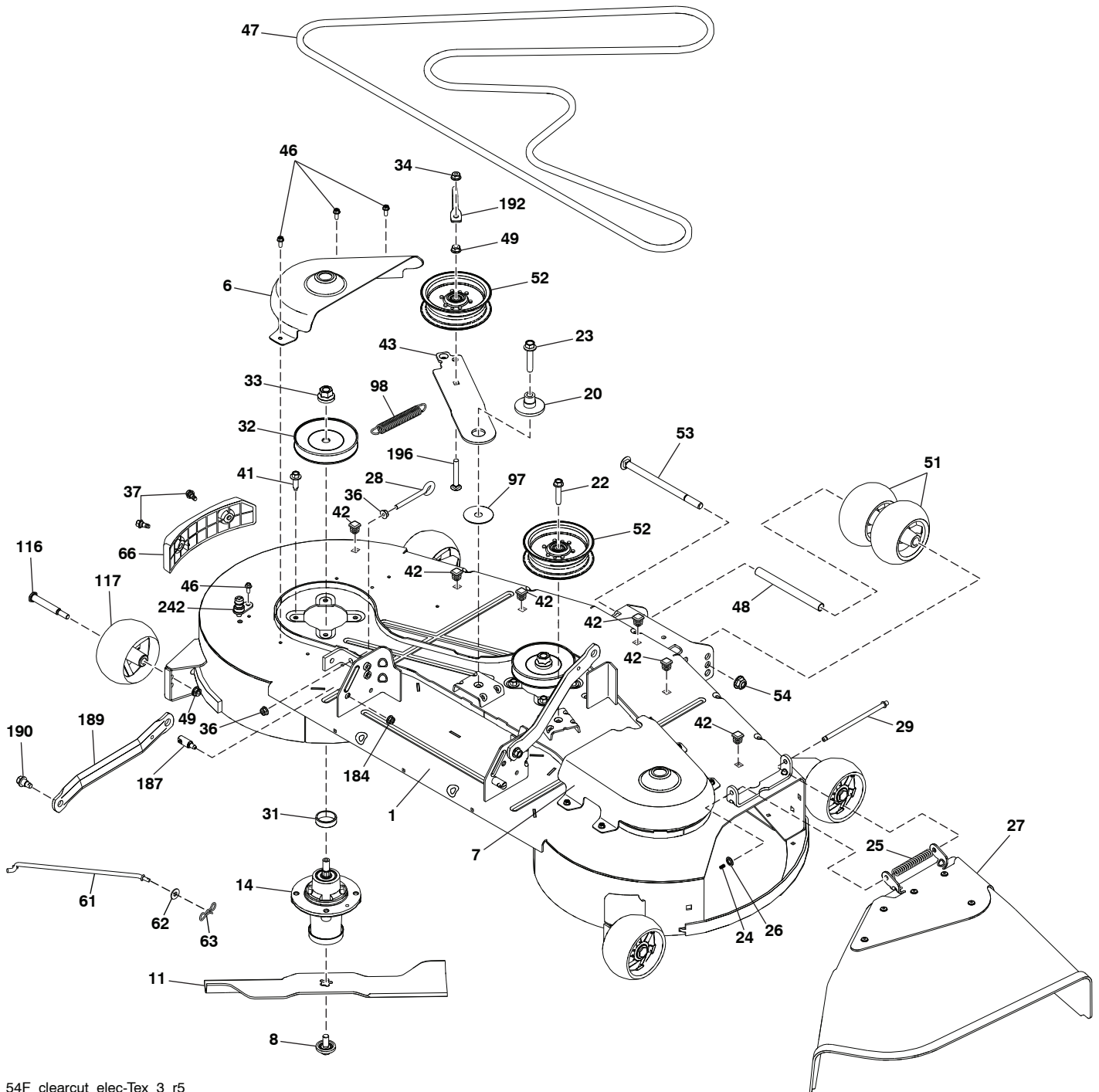

54F_clearcut_elec-Tex_3_r5

**TRACTOR MODELO NO. TS 354XD (96043030500), PRODUCTO NO. 960 43 03-05
PLATAFORMA DE LA CORTADORA DE CÉSPED**

CÓDIGO No.	PIEZA No.	DESCRIPCIÓN	CÓDIGO No.	PIEZA No.	DESCRIPCIÓN
1	592 61 88-01	Juego de Carcasa de la cortadora de césped	48	574 19 65-01	Rodillo, m
6	590 03 43-03	Brazo de la suspensión	49	873 90 06-00	Tuerca Flg. 3/8-16 unc
7	590 30 42-03	Tornillo #10 x 0.750 BOS	51	574 16 96-01	Calibradora,
8	532 19 30-03	Perno/arandela del ensamble de 7/16-20	52	532 19 73-79	Polea
11	582 76 05-08	Cuchilla de la cortadora	53	872 14 08-64	RHSNB 1/2--13 x / Gr. 5 ZD
14	539 13 18-98	Carcasa del mandril	54	521 99 11-01	Tuerca 1/2-13 Hex Flg
20	532 19 72-36	Polea loca	61	532 40 03-37	Barra contra la inclinación lateral
22	817 49 06-28	Tornillo 3/8-16 x 1-3/4	62	819 13 13-12	Arandela 13/32 x 13/16 x calibre 12
23	588 43 83-01	Tornillo 3/8-16 x 1-3/4 arandela	63	532 19 42-08	Perno de tope
24	532 10 53-04	Tapa de la manga	66	590 73 25-01	Parachoques 54cc
25	587 35 47-01	Resorte de torsión del deflector	97	532 17 85-15	Arandela
26	532 11 04-52	Tuerca de presión	98	587 35 84-01	Resorte
27	590 63 22-01	Protector del deflector	116	532 19 34-06	Perno
28	539 11 55-74	Perno 5/16-18	117	589 52 73-01	Calibrador de la rueda
29	532 13 14-91	Varilla de la bisagra	184	873 90 05-00	Sujetador del travesaño
31	532 18 76-90	Arandela del separador	187	532 19 51-61	Perno del perno prisionero
32	532 15 35-35	Polea del mandril	189	587 14 05-02	Tuerca de presión hexagonal con brida
33	532 40 02-34	Tuerca de seguridad con brida	190	532 19 65-39	Perno
34	873 68 06-00	Tuerca corona de presión de 3/8-16 unc	192	532 19 84-68	Sujetador
36	539 99 05-85	Tuerca de 5/16-18 Hex	196	539 12 81-01	Perno 3/8-16 unc x 2-1/2
37	532 17 01-65	Perno 5/16-18	242	532 41 55-98	Puerto de lavado de la cubierta
41	584 95 39-01	Perno .313 - 18 x 1.19	--	532 41 64-05	Acoplador
42	596 95 22-01	Tapón	--	592 61 89-01	Reemplazo de la cortadora de césped, completa
43	582 21 96-02	Resorte de torsión de retención			
46	532 13 77-29	Tornillo			
47	582 23 63-01	Soporte del cable de embrague			

NOTA: Las dimensiones de todos los componentes están expresadas en pulgadas americanas. 1 pulgada = 25,4 mm

**TRACTOR MODELO NO. TS 354XD (96043030500), PRODUCTO NO. 960 43 03-05
ELEVACIÓN DE LA CORTADORA DE CÉSPED**

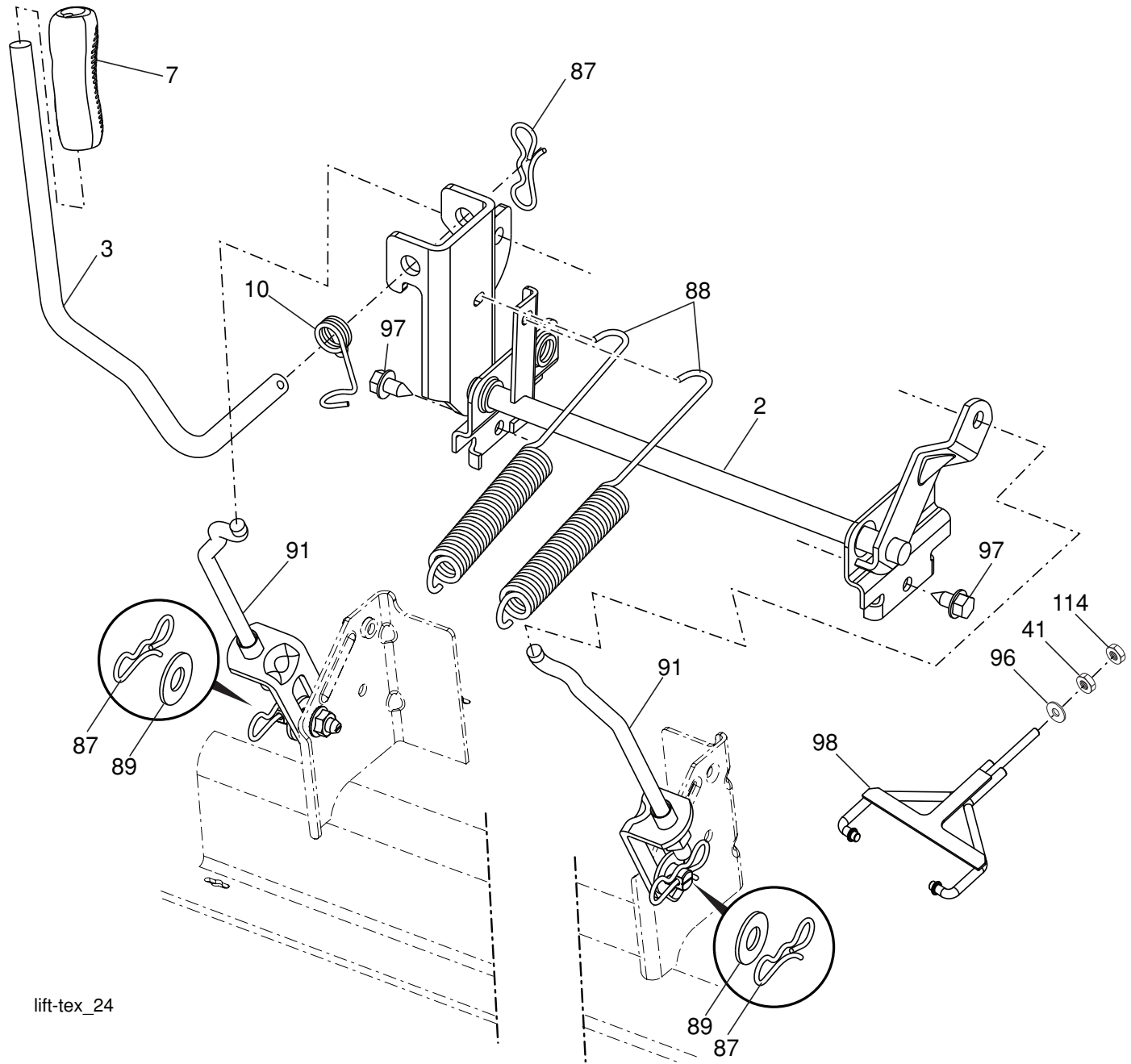

lift-tex_24

CÓDIGO No.	PIEZA No.	DESCRIPCIÓN
2	532 42 20-27	Ensamble del eje de la elevación
3	532 19 52-30	Ensamble de la palanca de elevación derecha
7	580 96 23-01	Mango de la palanca
10	532 19 63-14	Resorte de torsión
41	532 17 59-94	Tuerca
87	532 19 42-09	Pasador de chaveta de 7/16 con bloqueo en forma de mariposa
88	532 19 53-04	Resorte de ayuda de la elevación
89	819 19 19-12	Arandela de zinc transparente

CÓDIGO No.	PIEZA No.	DESCRIPCIÓN
91	532 40 34-07	Ensamble del acoplamiento Elevación trasera
96	532 19 52-63	Buje
97	817 00 06-12	Tornillo de 3/8-16 x 0,75
98	589 31 87-03	Acoplamiento frontal de la elevación de la cortadora de césped
114	873 36 07-00	Tuerca 7/16-20

NOTA: Las dimensiones de todos los componentes están expresadas en pulgadas americanas. 1 pulgada = 25,4 mm

**TRACTOR MODELO NO. TS 354XD (96043030500), PRODUCTO NO. 960 43 03-05
ENSAMBLE DEL ASIENTO**

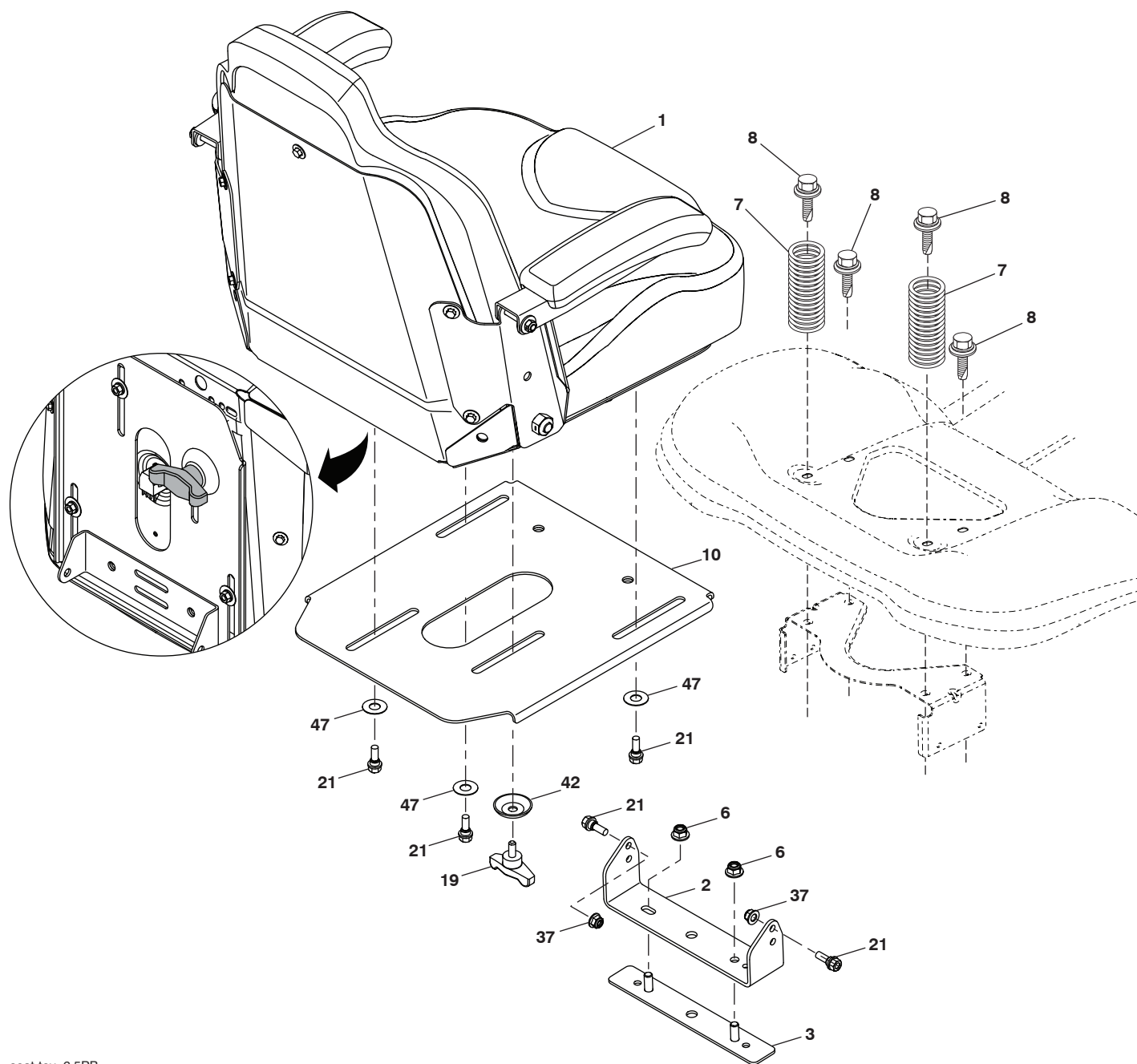

seat-tex_6.5PB

CÓDIGO No.	PIEZA No.	DESCRIPCIÓN
1	590 33 73-01	Asiento
2	590 33 66-02	Soporte pivotante del guardabarros
3	590 77 76-02	Conector del ensamble del guardabarros
6	521 99 65-01	Tuerca de 3/8 -16
7	590 81 23-01	Resorte del asiento
8	532 17 18-77	Perno de 5/16" unc x 3/4"
10	590 48 17-02	Bandeja del asiento

CÓDIGO No.	PIEZA No.	DESCRIPCIÓN
19	590 69 15-01	Asiento perilla 5/16-18 x 3/4
21	532 16 96-12	Perno de tope de 5/16-18
37	539 11 28-99	Tuerca de 5/16-18
42	532 19 93-71	Arandela taza
47	590 35 11-01	Arandela de nylon 50 x 1.12 x 003

NOTA: Las dimensiones de todos los componentes están expresadas en pulgadas americanas. 1 pulgada = 25,4 mm

CALCOMANÍAS

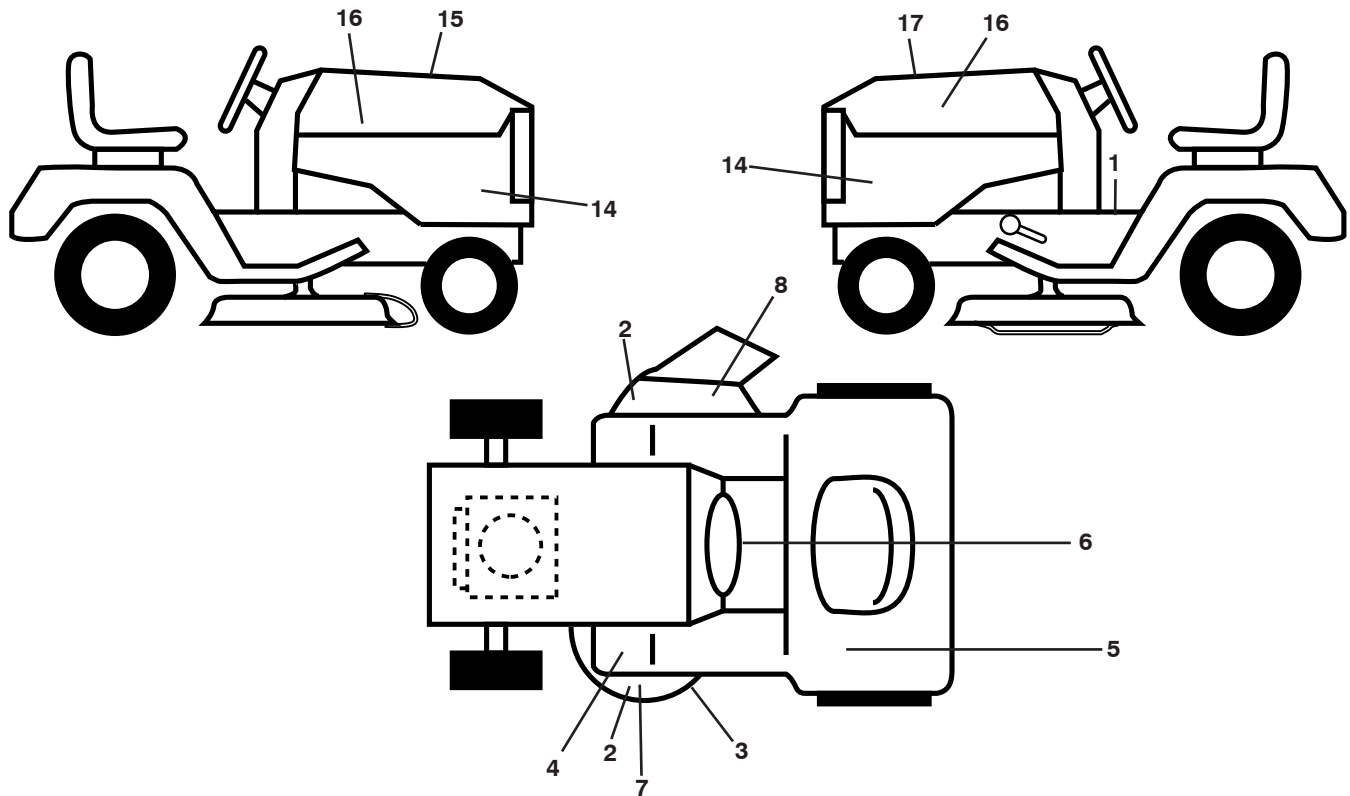

CÓDIGO No.	PIEZA No.	DESCRIPCIÓN
1	581 57 89-01	Calcomanía, Advertencia
2	589 35 79-01	Calcomanía, Ningún paso
3	592 89 83-01	Calcomanía, Advertencia
4	591 16 47-01	Calcomanía del diagrama de la cortadora de césped
5	597 47 01-01	Calcomanía, Reserva de combustible,
6	596 02 42-01	Calcomanía, Advertencia
7	593 80 88-01	Calcomanía, 54CC
8	586 97 88-01	Calcomanía, Advertencia

CÓDIGO No.	PIEZA No.	DESCRIPCIÓN
14	591 44 87-01	Calcomanía, Panel
15	532 42 38-29	Calcomanía
16	581 62 73-01	Calcomanía para la capota, logo
17	590 93 74-01	Calcomanía de reemplazo
--	581 72 48-01	Calcomanía para la desviación
--	532 43 98-82	Forro del apoyo para los pies izquierdo
--	532 43 98-81	Forro del apoyo para los pies derecho
--	114 19 11-49	Manual del operario (Inglés/Español)
--	114 19 18-27	Manual de repuestos (Inglés/Español)
--	587 71 00-26	Manual de QSG (Inglés/Español)

WHEELS AND TIRES

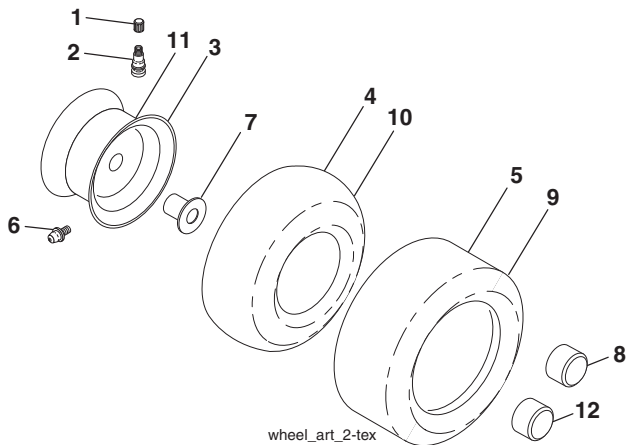

wheel_art_2-tex

CÓDIGO No.	PIEZA No.	DESCRIPCIÓN
1	532 05 91-92	Tapa de la válvula del neumático
2	532 06 51-39	Vástago de la válvula
3	532 18 18-39	Ensamble de las llantas delanteras
4	532 00 81-34	Cámara delantera
5	593 14 51-01	Neumático delantero 16 x 6.5-8
6	532 00 02-78	Accesorio para engrasar (solo para la rueda delantera)
7	532 00 90-40	Rodamiento de la brida (solo para la rueda delantera)
8	532 17 50-39	Tapa del eje frente
9	593 14 52-01	Neumático trasero 23 x 10.5-12
10	532 00 71-54	Cámara trasera (Mantenimiento sólo)
11	593 14 48-01	Ensamble trasero de la llanta
12	501 50 31-01	Tapa del eje trasero negro
--	532 14 43-34	Sellador para neumáticos (tubo de 10 onzas [283 gr])

NOTA: Las dimensiones de todos los componentes están expresadas en pulgadas americanas. 1 pulgada = 25,4 mm

NOTES/AVISO

NOTES/AVISO

NOTES/AVISO



www.husqvarna.com