

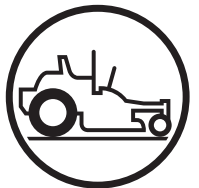

www.husqvarna.com



Parts Manual

Z 254 / 967 638501-00

Please read the operator manual carefully and make sure you understand the instructions before using the machine.

Gasoline containing a maximum of 10% ethanol (E10) is permitted for use in this machine. The use of gasoline with more than 10% ethanol (E10) will void the product warranty.

2019-02-26 JSE

115 85 34-27 Rev. D



When you need spare parts or support in service questions, warranty issues, etc., please consult the following professional:

This manual belongs to the machine with the manufacturing number:	Engine	Transmission

Ref.	Part No.	Qty	Description
1	587 59 56-01	1	Decal, Steer / Brake Lt
2	587 59 55-01	1	Decal, Steer / Brake Rt
3	587 21 01-01	2	Decal, Z 254
4	539 10 57-45	1	Decal, Battery Warning
5	532 42 86-77	1	Decal, Crown
6	539 10 83-85	1	Decal, Do Not Tow
7	539 10 83-86	1	Decal, Exit Mower
8	539 10 98-97	1	Decal, Service
9	590 48 55-01	1	Decal, Safety Warnings
10	532 42 38-29	1	Decal, Responsibility
11	586 25 84-01	1	Decal, Start
12	581 72 44-01	1	Decal, Deflector
13	584 90 46-01	1	Decal, Blade Danger
14	539 11 26-20	1	Decal, Belt Routing
15	577 46 90-01	2	Decal, Husqvarna
16	587 00 07-01	1	Pad, Abrasive

Manufacturing Number

The machine's manufacturing number can be found on the printed plate affixed to the engine compartment.

Stated on the plate, from the top are:

- The machine's type designation (I.D.).
- The manufacturer's type number (Model).
- The machine's serial number (Serial no.)

Please have the type designation and serial number available when ordering spare parts.

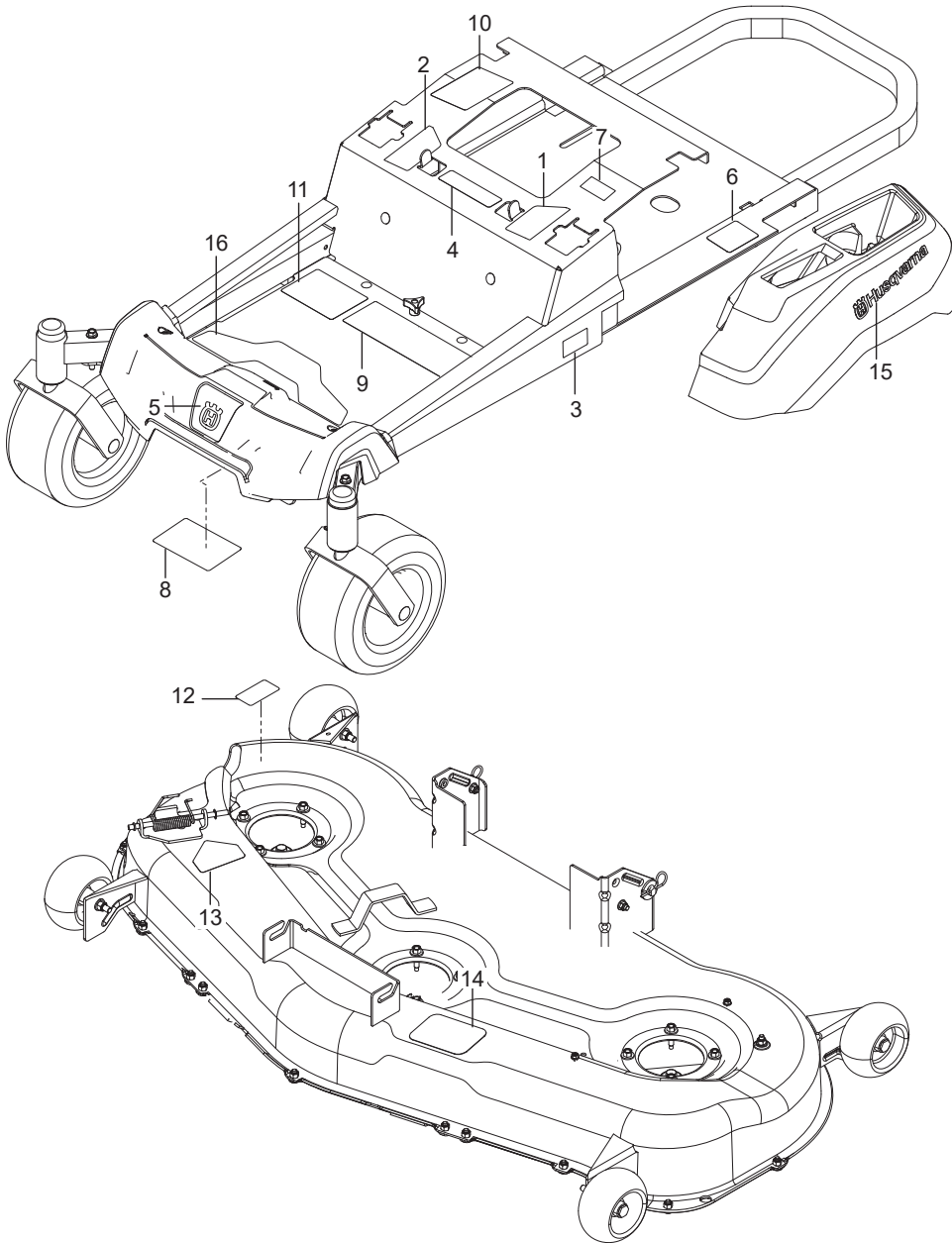

FRAME4

ENGINE MOUNTING, GUARDS & MUFFLER6

STEERING8

IGNITION SYSTEM.....10

BRAKE / LIFT12

HYDRAULIC PUMP-MOTOR..... 14

WHEELS & TIRES16

MOWER DECK / CUTTING DECK18

SEAT20

DECALS22

Illustrations may or may not represent the actual assemblies and it is not recommended to use this manual as a guide to assemble or disassemble the mower.

NOTE: All fasteners are Grade 5 unless otherwise specified.

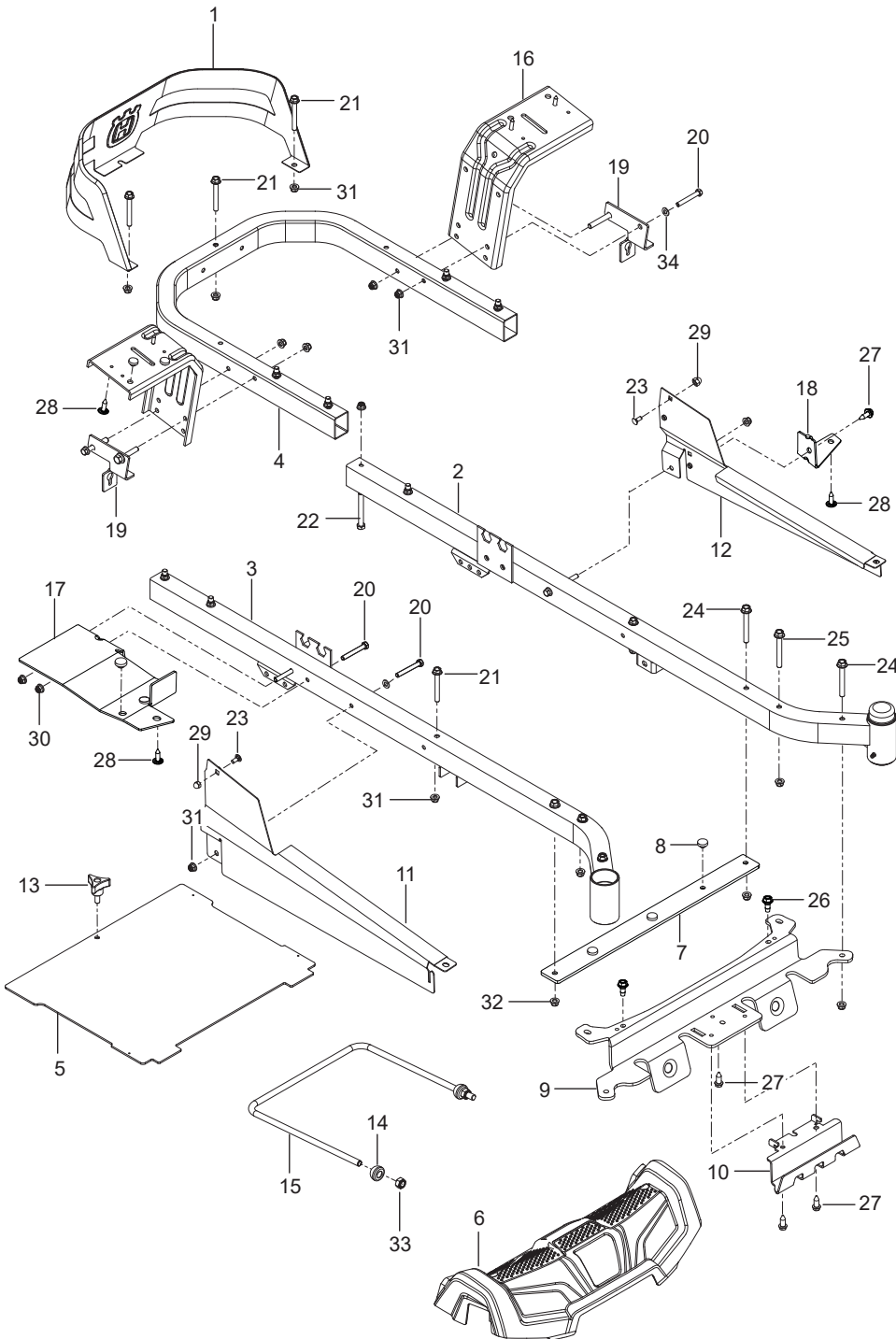

Ref.	Part No.	Qty	Description
1	532 43 98-22	1	Seat
2	587 23 20-02	1	Pan, Seat
3	586 22 08-02	1	Plate, Lift Support
4	586 22 12-02	1	Plate, Deck Lift
5	589 48 12-06	1	Support, Seat Org
6	580 30 82-02	2	Support, Seat Rear Blk
7	532 19 82-00	1	Spring, Latch
8	587 61 33-01	2	Spring, Seat
9	532 40 15-45	1	Switch, Seat
10	532 19 76-61	1	Handle, Slide
11	586 42 86-01	1	Leg, Support
12	585 98 93-01	2	Grommet, Bumper
13	539 10 47-63	5	Retainer, U Type
14	872 14 05-06	4	Bolt 5/16-18 x 3/4 Round Head Square Neck
15	510 42 27-01	2	Bolt 5/16-18 x 2-1/2 Round Head Square Neck
16	874 78 06-20	2	Bolt 3/8-16 x 1-1/4
17	874 78 06-10	1	Bolt 3/8-16 x 5/8
18	539 11 03-03	2	Bolt 5/16-18 Shoulder
19	817 49 05-12	4	Screw 5/16-18 x 3/4 Thread Form
20	817 00 05-10	6	Screw 5/16-18 x 5/8 Washer Head
21	539 11 28-99	4	Nut 5/16-18 Hex Flange Nyloc
22	521 99 65-01	2	Nut 3/8-16 Hex Flange Nyloc
23	539 11 18-97	1	Washer 3/8 Special
24	819 14 16-14	2	Washer 3/8 Std Flat
NOT SHOWN - OPTIONAL			
	532 42 14-99	1	Kit, Arm Rest

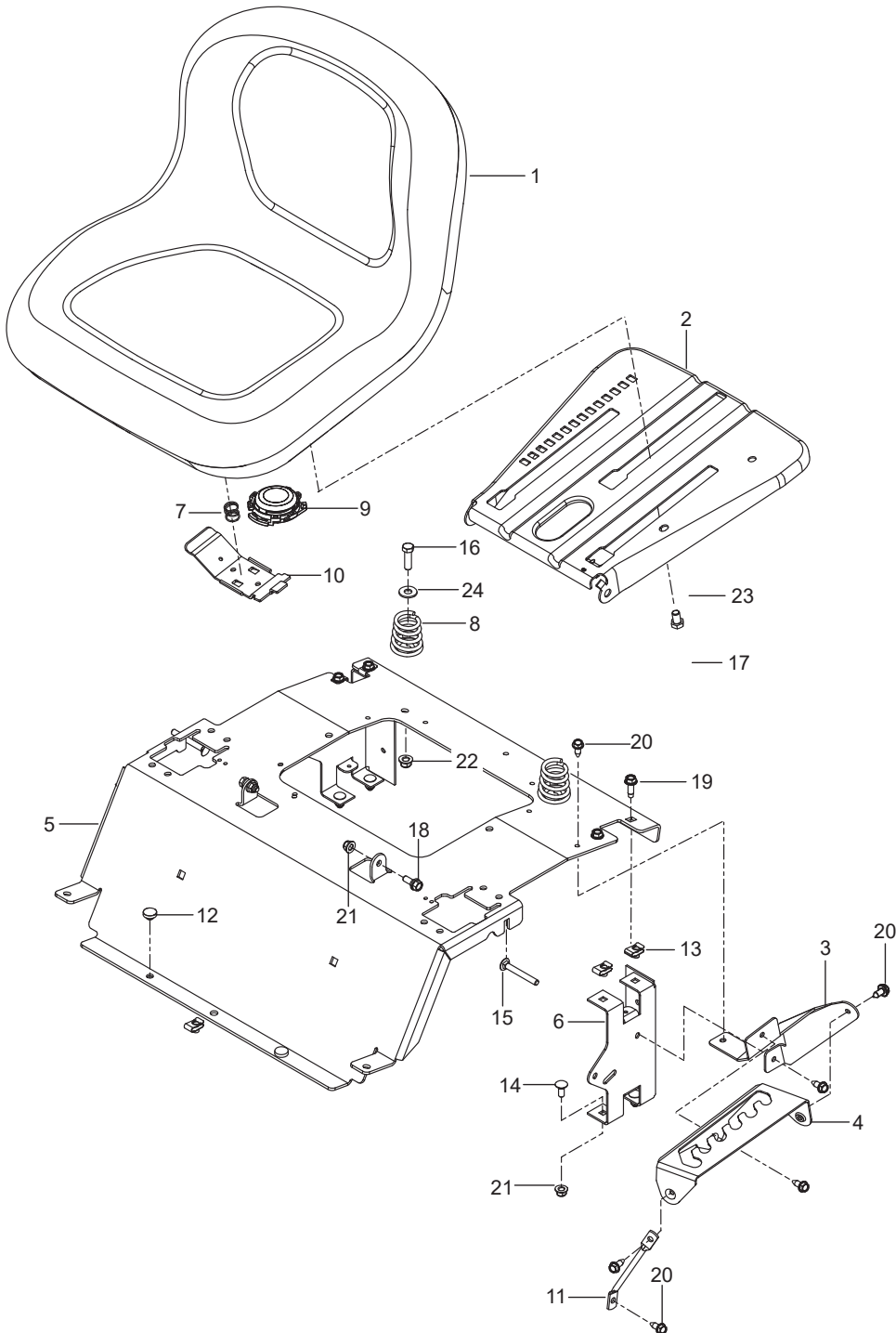

Ref.	Part No.	Qty	Description
1	585 03 98-02	1	Guard, Rear Blk
2	589 28 34-02	1	Frame, Front Right Org
3	589 28 33-02	1	Frame, Front Left Org
4	584 99 10-02	1	Frame, Rear Tube Org
5	522 84 29-02	1	Foot Plate w/ Safety Decal
6	585 52 24-01	1	Cover, Footrest
7	585 52 30-04	1	Support, Footrest
8	585 98 93-01	7	Grommet, Bumper
9	585 52 31-04	1	Cross Member
10	585 52 32-04	1	Plate, Skid Silv
11	585 33 16-02	1	Cover, Rail Right
12	585 33 15-02	1	Cover, Rail Left
13	539 10 44-11	1	Knob w/ Stud
14	532 19 52-63	2	Bushing, Pivot
15	521 93 81-01	1	Link, Front Suspension
16	580 50 13-02	2	Support, Fender Blk
17	585 52 34-04	1	Support, Console Right
18	585 52 36-04	1	Support, Console Left
19	585 47 43-02	2	Bracket, Bypass Rod
20	874 78 05-36	8	Bolt 5/16-18 x 2-1/4
21	874 49 05-44	5	Bolt 5/16-18 x 2-3/4
22	874 78 06-48	8	Bolt 3/8-16 x 3
23	585 94 00-01	2	Bolt 5/16-18 x 1 Carriage
24	577 11 77-01	4	Bolt 3/8-16 x 3
25	586 65 43-01	2	Bolt 3/8-16 x 3 Shoulder
26	586 88 11-01	2	Bolt 5/16-18 Shoulder
27	817 00 05-10	4	Screw 5/16-18 x 5/8 Washer Head
28	532 41 63-58	6	Screw #10-24 x 3/4 Hex Head
29	585 93 81-01	2	Nut 5/16-18 Acorn
30	873 90 05-00	2	Nut 5/16-18 Hex Flange Lock
31	539 11 28-99	9	Nut 5/16-18 Hex Flange Nyloc
32	521 99 65-01	8	Nut 3/8-16 Hex Flange Nyloc
33	539 11 91-24	2	Nut 7/16-14 Hex Nyloc
34	819 11 11-16	6	Washer 5/16 Sae Flat

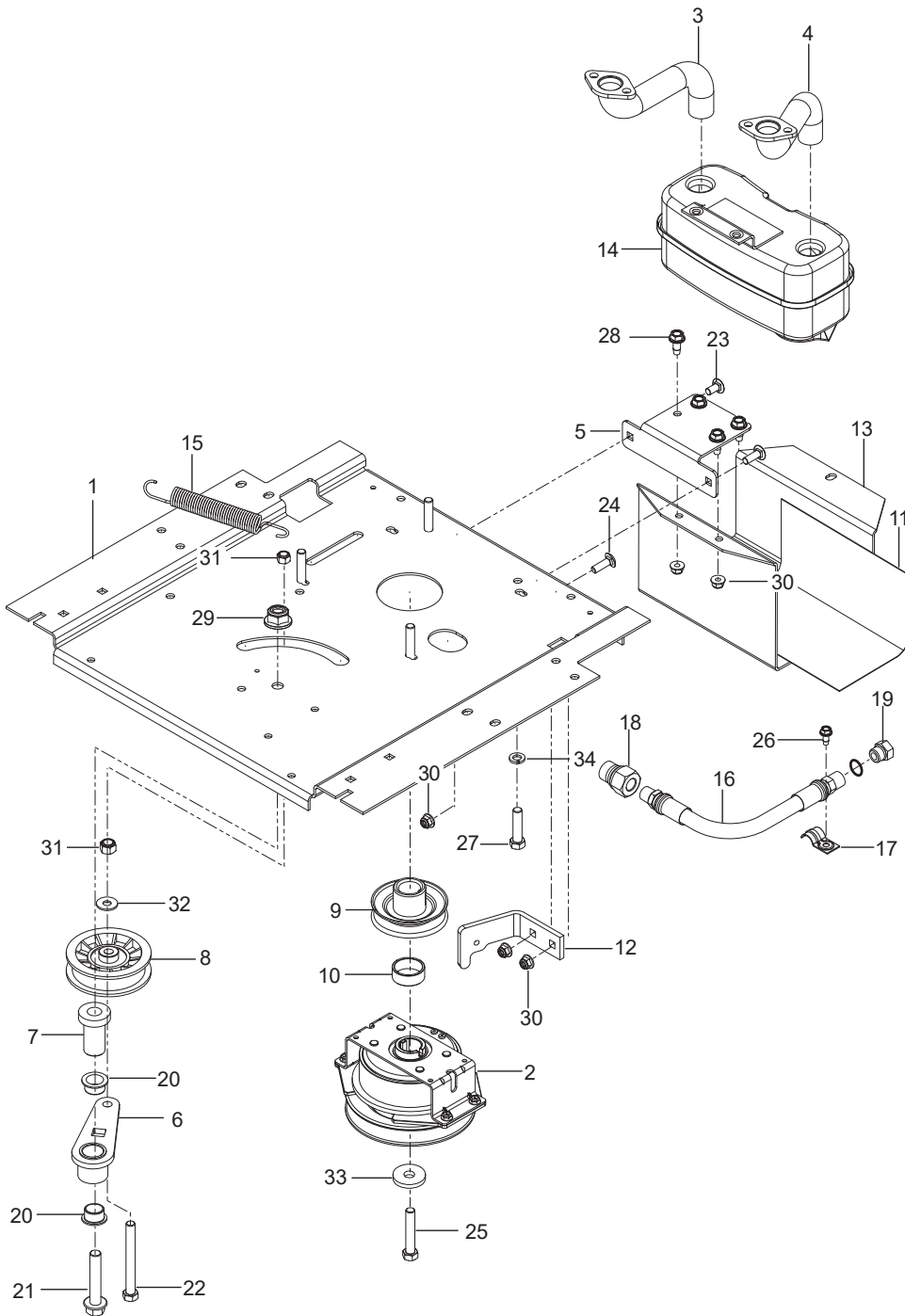

Ref.	Part No.	Qty	Description
1	583 90 93-01	1	Deck w/ decals, Org
2	539 11 45-57	1	V-Belt
3	532 18 72-56	3	Blade, Bagging
4	532 18 72-97	1	Belt Shield, Left
5	532 18 81-87	1	Belt Shield, Right
6	587 12 54-01	3	Assembly, Mandrel
7	589 52 73-01	4	Wheel, Gauge
8	532 17 34-36	3	Pulley
9	532 19 61-06	2	Pulley, Idler
10	532 19 61-04	1	Pulley, Idler
11	532 18 72-57	1	Deflector
12	522 62 97-01	1	Keeper, Belt
13	532 13 14-91	1	Rod, Hinge
14	532 11 04-85	1	Bearing
15	510 22 00-02	1	Arm, Idler
16	532 41 55-98	1	Port, Washout
17	532 41 64-05	1	Coupling, Quick Connect
18	539 12 09-20	1	Spring, Deck Belt
19	532 17 81-02	1	Spring, Torsion
20	532 19 51-61	2	Stud, w/ Anti-Rotate
21	532 18 72-91	1	Shaft
22	539 97 69-89	2	Hairpin #4
23	532 18 73-42	1	Baffle, Right
24	532 18 73-44	1	Baffle, Left
25	532 18 76-07	1	Baffle, Center
26	585 32 26-05	1	Plate, Front
27	585 32 28-05	1	Plate, Side
28	874 78 07-40	1	Bolt 7/16-14 x 2-1/2 Hex Head
29	539 10 72-71	5	Bolt 5/16-18 x 1 Round Head Square Neck
30	872 11 05-10	7	Bolt 5/16-18 x 1-1/4 Round Head Square Neck
31	539 11 55-74	1	Eye Bolt 5/16 x 3-1/2
32	539 12 81-01	1	Bolt 3/8-16 x 2-1/4 Carriage
33	532 19 34-06	4	Bolt 3/8-16 x 3-5/8 Shoulder
34	584 30 93-01	3	Bolt, Blade
35	584 95 39-01	12	Bolt 5/16-18 x Hex Washer Head
36	532 19 65-39	2	Bolt, Shoulder
37	817 49 04-08	1	Screw 1/4-20 x 1/2 Hex Washer Head
38	532 13 77-29	4	Screw 1/4-20 x 5/8 Thread Roll
39	873 80 06-00	6	Nut 3/8-16 Hex Nyloc
40	873 80 05-00	5	Nut 5/16-18 Hex Nyloc
41	873 68 05-00	7	Nut 5/16-18 Crown Lock
42	532 40 02-34	3	Nut 9/16 Top Center Lock
43	532 11 04-52	1	Pushnut
44	539 99 05-85	1	Nut 5/16-18 Hex Whiz Lock
45	539 11 28-99	3	Nut 5/16-18 Flange Nyloc
46	539 11 91-24	1	Nut 7/16-14 Hex Nyloc
47	819 14 16-14	3	Washer 3/8 Flat Std
48	539 10 48-64	3	Washer 7/16 Flat
49	819 11 11-16	12	Washer 5/16 SAE Flat
50	819 13 13-16	4	Washer 16 Gauge
51	819 21 21-13	2	Washer 1/2 Flat

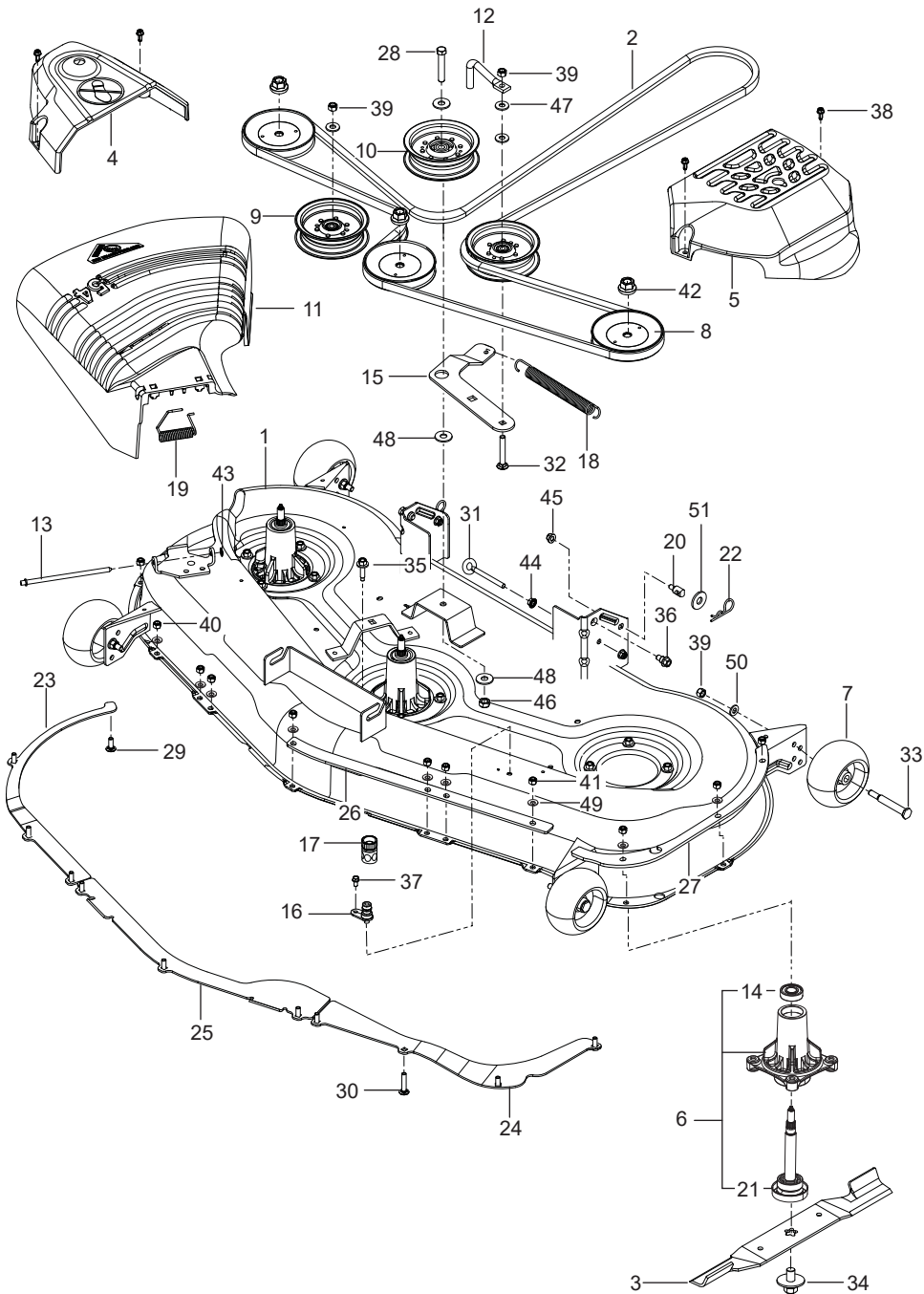

Ref.	Part No.	Qty	Description
1	588 01 71-02	1	Plate, Engine Blk
2	587 24 16-01	1	Clutch
3	583 95 57-01	1	Tube, Exhaust Right
4	583 95 56-01	1	Tube, Exhaust Left
5	581 88 67-02	1	Bracket, Muffler Blk
6	532 44 81-45	1	Arm, Idler
7	582 53 89-01	1	Spindle, Idler
8	539 11 03-11	1	Pulley, Idler
9	587 53 74-01	1	Pulley, Engine
10	587 66 01-01	1	Spacer
11	539 13 28-59	1	Shield, Muffler
12	587 63 33-02	1	Stop, Clutch Blk
13	587 45 12-02	1	Guard, Muffler Blk
14	539 13 16-04	1	Muffler Assembly
15	532 19 61-05	1	Spring, Deck Drive
16	584 82 55-01	2	Assy, Drain Hose
17	539 10 13-63	1	Clamp
18	522 59 90-01	1	Adapter, Oil Drain
19	585 80 71-01	1	Plug, Oil
20	501 60 37-01	2	Bearing, Flanged
21	582 53 95-01	1	Bolt 1/2-13 x 2-3/4 Hex Flange Head
22	874 52 06-56	1	Bolt 3/8-16 x 3-1/2 Hex Head
23	539 99 03-16	2	Bolt 5/16-18 x 3/4 Round Head Square Neck
24	539 99 02-08	2	Bolt 5/16-18 x 1 Round Head Square Neck
25	581 33 28-04	1	Bolt 7/16-20 x 3-1/2 Hex Head
26	817 49 04-10	1	Screw 1/4-20 X 5/8 Thread Form
27	874 78 06-20	4	Bolt 3/8-16 x 1-1/4
28	817 49 05-12	4	Screw 5/16-18 x 3/4 Thread Form
29	521 99 11-01	1	Nut 1/2-13 Hex Flange Nyloc
30	539 11 28-99	5	Nut 5/16-18 Hex Flange Nyloc
31	539 97 69-79	2	Nut 3/8-16 Hex Nyloc
32	819 12 14-14	2	Washer 5/16 Std Flat
33	532 12 61-97	1	Washer, Clutch
34	810 03 06-00	4	Washer 3/8 Split Lock
	NOT SHOWN		
	522 59 86-01	1	Pigtail
	589 54 39-01	1	Idler Arm Kit
	-----	1	Engine, Kawasaki FX691V 23 HP For Engine Replacement Parts, See a Kawasaki Dealer

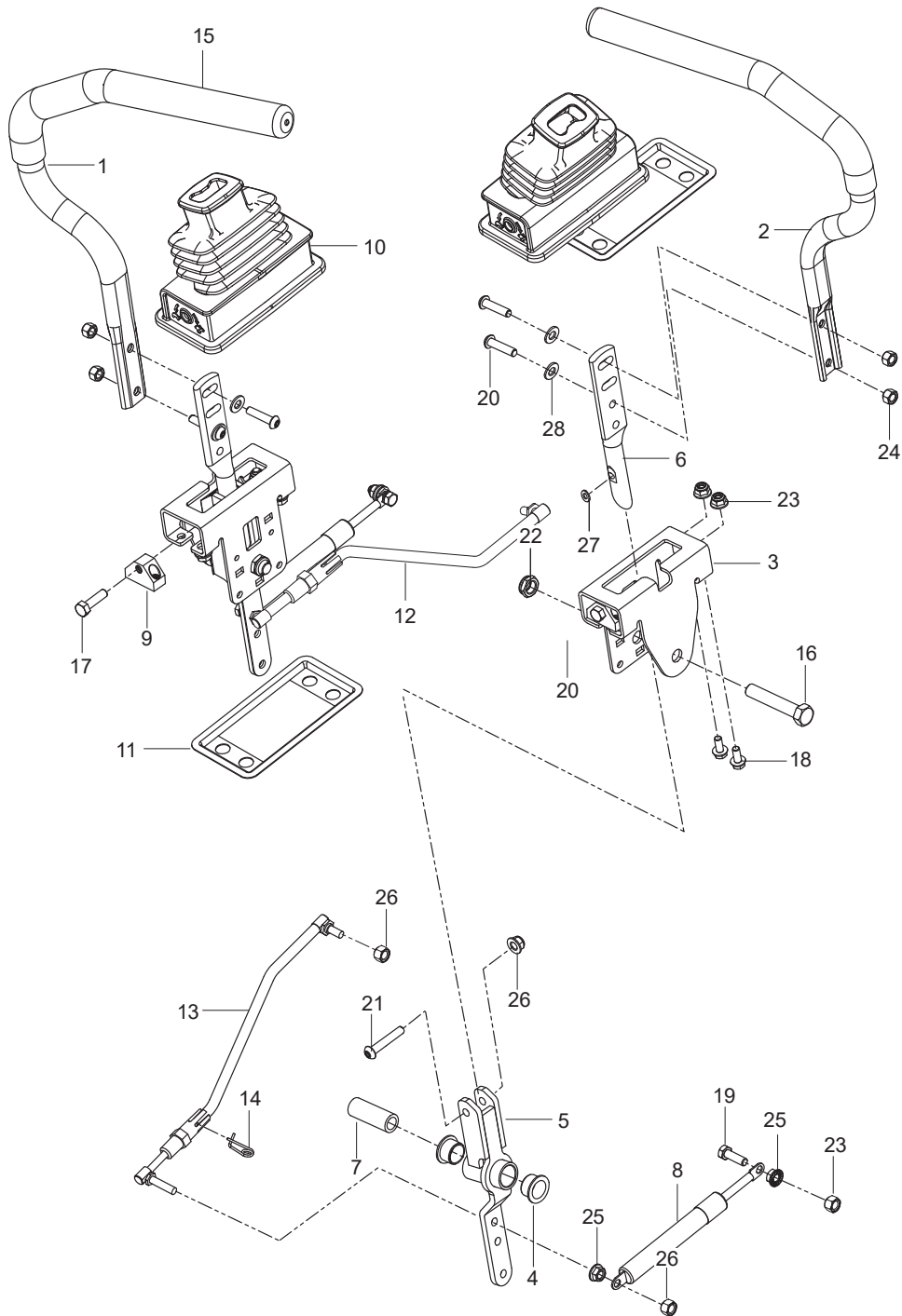

Ref.	Part No.	Qty	Description
1	590 48 66-01	2	Assy, Wheel Rear 18 x 9.5
2	576 58 86-02	2	Wheel Assy Caster 11 x 6.5
3	586 65 03-02	2	Yoke Org
4	539 11 56-38	2	Zerk 3/16 Drive
5	539 10 33-00	2	Zerk
6	539 11 26-60	2	Bearing, Flanged
7	539 11 79-01	2	Bushing, Caster
8	539 10 25-35	2	Grease Cap
9	539 11 57-49	2	Plug, Caster
10	576 58 89-01	2	Spacer, Pivot
11	539 11 57-47	2	Spring, Caster
12	874 95 05-16	2	Bolt, Hex 5/16-18 x 1 Nyloc
13	576 60 15-01	2	Bolt 1/2-13 x 7-1/2 Round Head Square Neck
14	873 93 08-00	2	Nut 1/2-13 Hex Center Lock
15	539 10 11-73	8	Nut 1/2 Lug
16	539 11 56-75	2	Washer
17	819 18 22-12	2	Washer 9/16

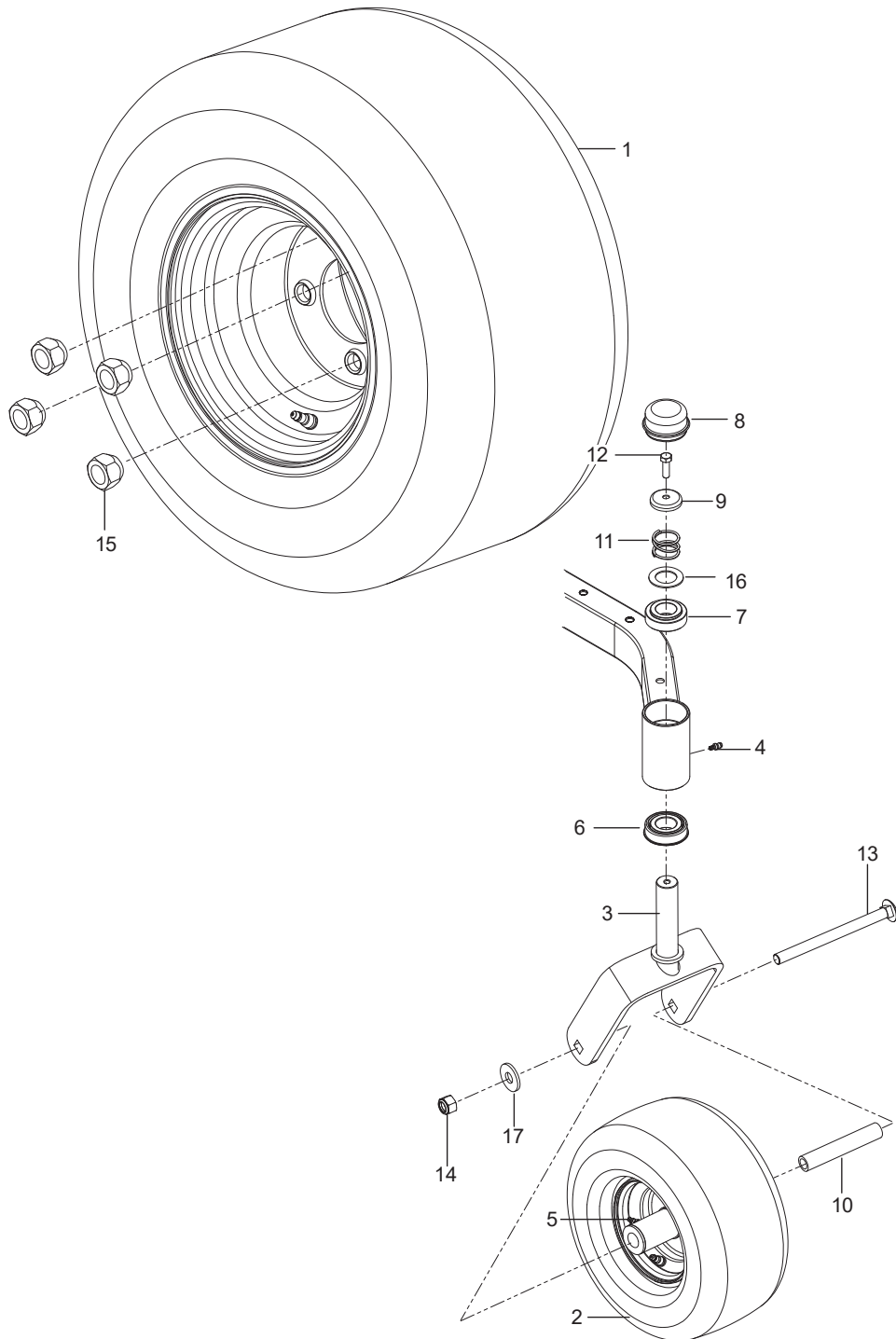

Ref.	Part No.	Qty	Description
1	590 09 08-03	1	Lever w/ Grip Right Blk
2	590 09 08-04	1	Lever w/ Grip Left Blk
3	585 12 47-05	2	Bracket, Control
4	539 13 15-18	4	Bearing, Flanged
5	576 14 03-01	2	Control, Lever
6	587 60 17-02	2	Lever, Handle
7	584 92 72-01	2	Spacer, Pivot Control
8	539 10 27-20	2	Dampener
9	581 43 75-01	2	Block, Tracking
10	585 83 16-01	2	Boot, Steering
11	585 48 82-02	2	Flange, Boot
12	588 60 49-01	2	Assy, Right Control Linkage
13	588 60 50-01	2	Assy, Left Control Linkage
14	532 19 98-49	2	Clip, Spring
15	525 39 29-02	2	Grip, Foam
16	874 78 08-44	2	Bolt 1/2-13 x 2-3/4 Hex Head
17	585 98 61-01	2	Bolt 5/16-18 x 1-1/4 Hex Head
18	874 49 05-12	8	Bolt Hex Flange 5/16-18 x 3/4
19	874 78 05-16	4	Bolt 5/16-18 x 1 Thread Form
20	585 98 59-01	4	Screw 5/16-18 x 1-1/4 Button Head Blk
21	576 85 04-02	2	Screw 5/16-18 x 1-3/4 Button Head
22	539 10 80-10	2	Nut 1/2-13 Hex Jam Nyloc Grade 2
23	539 11 28-99	10	Nut 5/16-18 Hex Flange Nyloc
24	585 98 60-01	4	Nut 5/16-18 Hex Nyloc Blk
25	539 99 05-85	4	Nut 5/16-18 Hex Whiz Lock
26	873 80 05-00	8	Nut 5/16-18 Hex Nyloc
27	587 61 42-01	2	Washer 11/32
28	819 11 11-16	4	Washer 5/16 SAE Flat

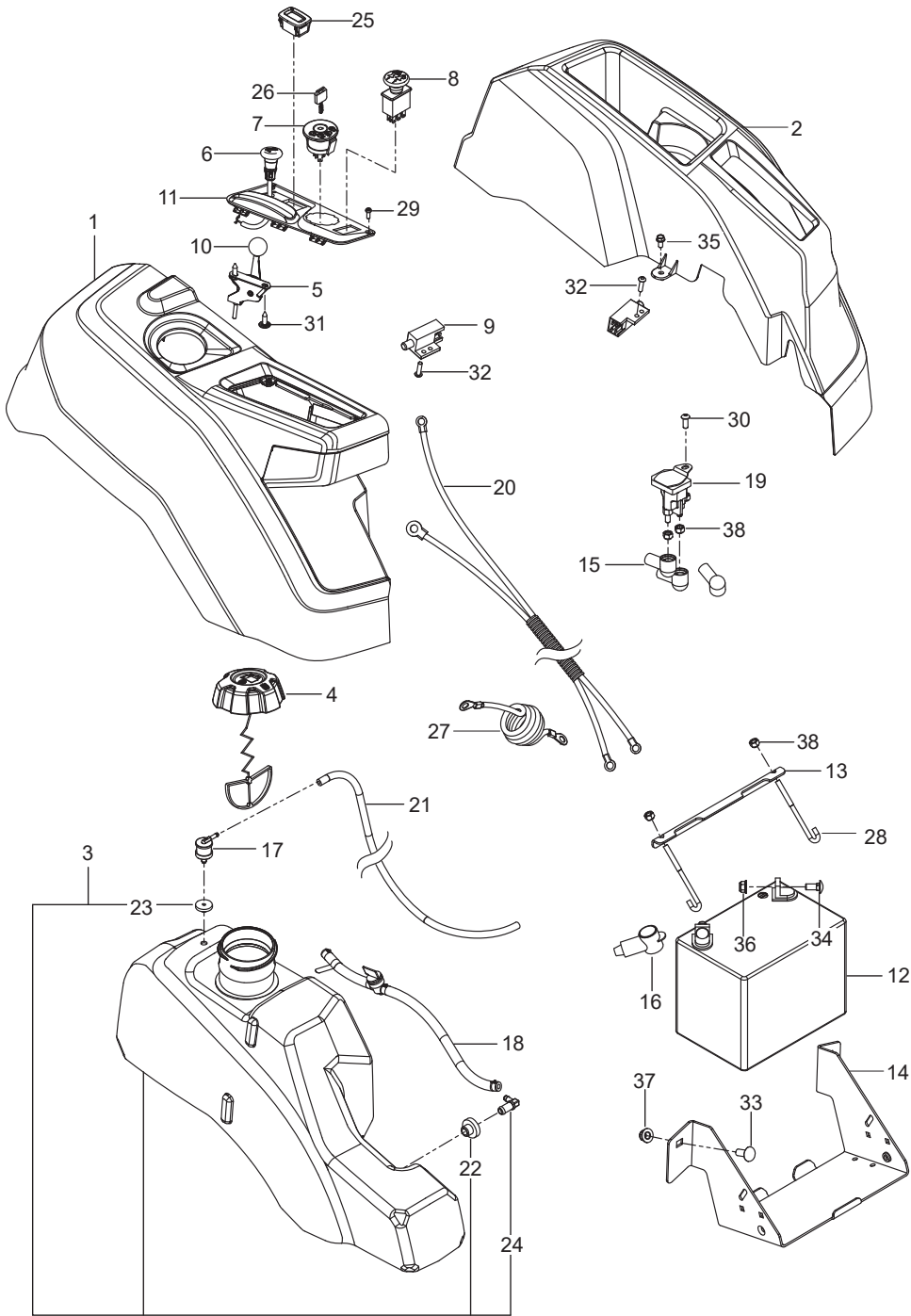

Ref.	Part No.	Qty	Description
1	510 37 56-01	1	EZT, Left
2	510 37 56-02	1	EZT, Right
3	574 03 05-01	1	Rod, EZT Brake Left
4	574 03 05-02	1	Rod, EZT Brake Right
5	539 11 04-11	1	Belt, EZT
6	585 47 44-01	1	Rod, Bypass Left
7	585 47 45-01	1	Rod, Bypass Right
8	586 66 51-01	2	Spring, Bypass
9	539 11 03-42	2	Spring, Brake Rod
10	539 12 00-80	2	Cog, Brake Disc
11	539 12 00-79	2	Assembly Kit, Brake Arm
12	575 50 70-01	1	Assembly Kit, Hub w/ Nuts
13	501 40 36-02	2	Assembly Kit, Blade, Pulley
14	510 18 41-04	2	Spacer Tube
15	580 80 65-02	2	Support, EZT Front
16	580 80 66-02	2	Mount, EZT Rear Blk
17	587 22 53-01	1	Clip
18	539 97 69-88	4	Clip
19	587 11 53-01	1	Pin, Clevis
20	874 78 05-44	4	Bolt 5/16-18 x 2-3/4
21	539 97 69-34	2	Bolt 5/16-18 x 3/4
22	874 78 05-36	2	Bolt 5/16-18 x 2-1/4
23	539 99 06-37	4	Bolt 3/8-16 x 2-1/2
24	873 80 05-00	8	Nut 5/16-18 Hex Nyloc
25	873 80 04-00	2	Nut 1/4-20 Hex Nyloc
26	819 11 11-16	16	Washer 5/16 SAE Flat
27	810 03 06-00	4	Washer 3/8 Splt Lock
28	819 13 13-16	8	Washer 3/8 SAE Flat
29	819 09 10-16	4	Washer 1/4 SAE Flat

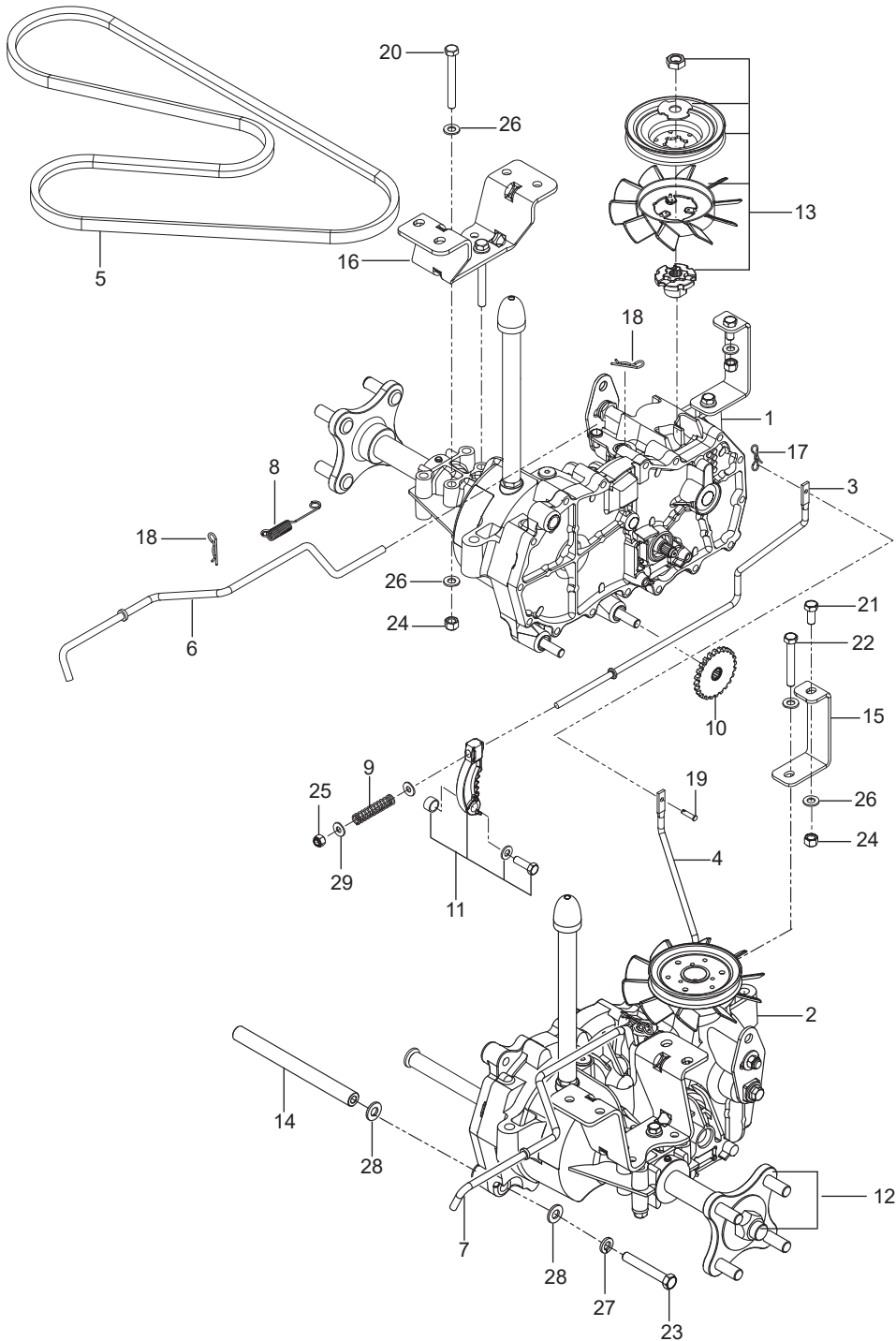

Ref.	Part No.	Qty	Description
1	585 52 28-01	1	Assembly, Fender, Right Gry
2	586 62 12 01	1	Assembly, Fender, Left Gry
3	589 92 47-01	1	Assembly, Fuel Tank
4	585 12 48-01	1	Cap, Fuel w/ Tether
5	539 11 24-38	1	Cable, Throttle
6	586 88 15-01	1	Control, Choke
7	539 10 75-41	1	Switch, Ignition
8	582 10 76-02	1	Switch, Clutch
9	587 60 15-01	2	Switch, Interlock
10	539 13 30-49	1	Knob
11	585 52 27-01	1	Panel, Control
12	579 41 16-01	1	Battery
13	510 03 00-03	1	Bracket, Battery
14	582 60 96-02	1	Box, Battery Blk
15	532 13 15-63	3	Terminal Cover
16	539 10 27-59	1	Terminal Cover
17	576 61 81-01	1	Valve, Fuel Check
18	586 12 39-06	1	Assembly, Fuel Line w/ Valve
19	582 04 28-01	1	Solenoid
20	587 19 86-01	1	Harness, Battery Cable
21	587 04 45-50	1	Hose 3/16 x 50" Vapor
22	532 00 36-45	1	Grommet, Rubber
23	532 43 74-92	1	Grommet, Check Valve
24	532 13 92-77	1	Elbow
25	586 16 18-01	1	Meter, Service
26	532 14 04-01	1	Key, Ignition
27	539 10 33-06	1	Cable, Battery Positive
28	588 83 94-01	2	J Hook
29	545 22 71-01	2	Screw 6-19 x 7/16 Pan Head
30	539 11 12-29	1	Screw 1/4-20 x 5/8 Button Socket
31	532 14 18-41	2	Screw 10-16 x .65
32	586 93 60-01	2	Screw #10-24 x 1/2 Socket Head
33	539 99 06-45	2	Bolt 3/8-16 x 1 Round Head Square Neck
34	872 14 05-06	2	Bolt 5/16-18 x 3/4 Round Head Square Neck
35	817 49 04-08	2	Bolt 1/4-20 x 1/2
36	539 11 28-99	2	Nut 5/16-18 Flange Nyloc
37	521 99 65-01	2	Nut 3/8-16 Hex Flange Nyloc
38	873 80 04-00	5	Nut 1/4-20 Hex Nyloc
	NOT SHOWN		
	586 33 73-01	1	Harness, Wiring
	532 10 97-48	1	Relay 40A

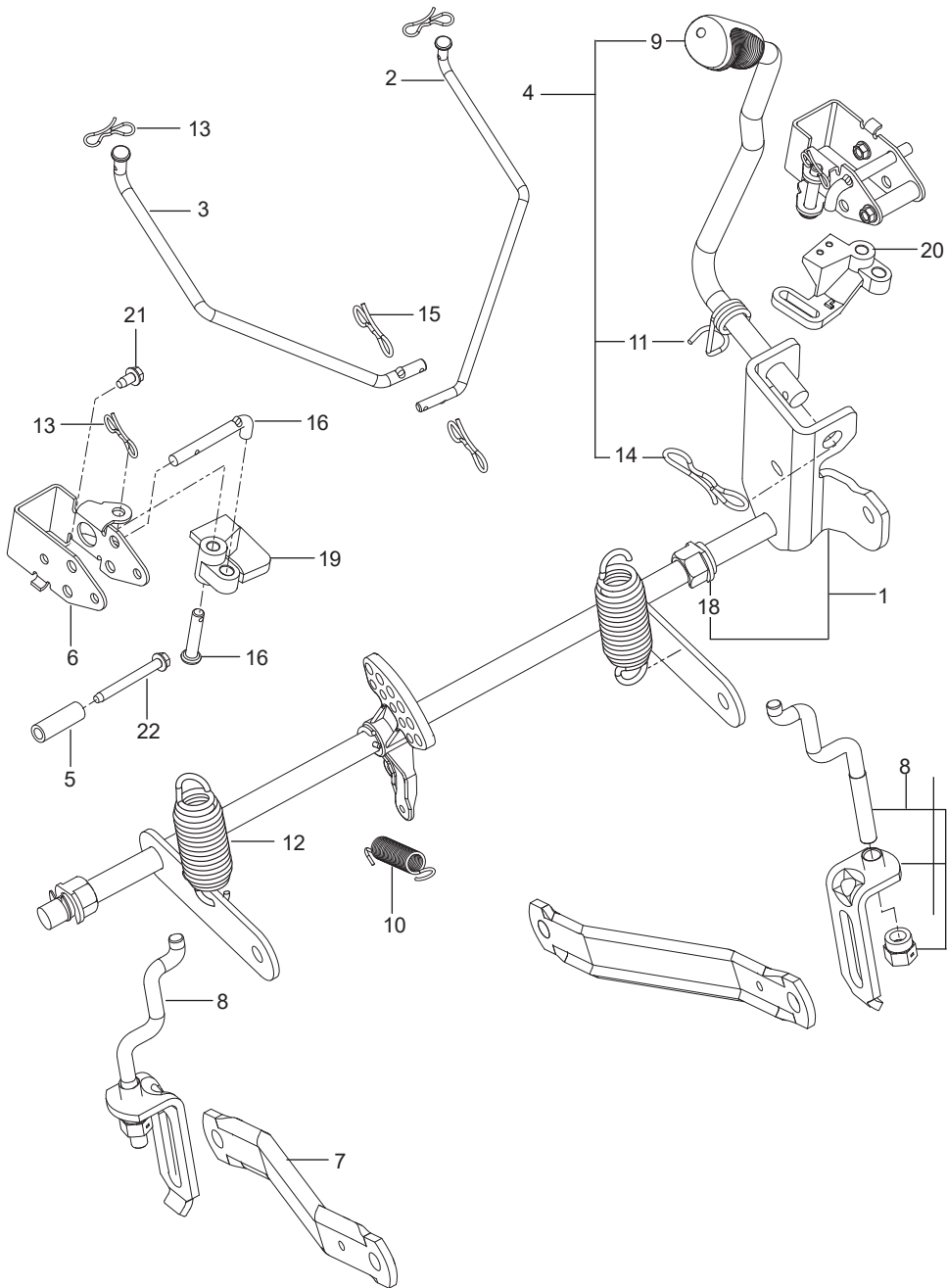

Ref.	Part No.	Qty	Description
1	587 62 31-01	1	Assembly, Shaft w/ Nuts, E-Rings
2	586 45 71-01	1	Link, Brake Left
3	586 45 72-01	1	Link, Brake Right
4	587 62 29-01	1	Assembly, Lift Handle
5	580 48 61-01	2	Spacer
6	585 68 21-01	2	Bracket, Bellcrank
7	532 19 51-85	2	Arm, Suspension
8	587 62 30-01	2	Assembly, Centering Lnk
9	532 44 50-60	1	Grip, Handle
10	586 86 76-01	1	Spring
11	532 19 63-14	1	Spring
12	539 11 87-62	2	Spring
13	587 22 53-01	4	Clip 3/16 X 1 Bowtie
14	532 19 42-09	1	Clip 7/16 X 2-3/4 Bowtie
15	532 19 42-08	2	Clip 5/16 X 1-7/8 Bowtie
16	585 70 14-01	2	Pin 1/2 Clevis
17	585 68 20-01	2	Pushrod
18	510 18 49-01	2	Nut, Plastic
19	586 45 75-01	1	Bellcrank Right
20	586 45 74-01	1	Bellcrank Left
21	532 13 77-29	2	Screw 1/4 x 5/8 Thread Roll
22	586 56 13-01	2	Screw 1/4-20 x 2-1/4 Thread Roll