



www.husqvarna.com



Parts Manual

V 548 / 967 672501-00

Please read the operator manual carefully and make sure you understand the instructions before using the machine.

Gasoline containing a maximum of 10% ethanol (E10) is permitted for use in this machine. The use of gasoline with more than 10% ethanol (E10) will void the product warranty.

2019-03-18 SR

115 94 31-27 Rev. I



When you need spare parts or support in service questions, warranty issues, etc., please consult the following professional:

This manual belongs to the machine with the manufacturing number:	Engine	Transmission

Ref.	Part No.	Qty	Description	Kit / Assy Includes
1	584 90 46-01	1	Decal, Blade Warning	
2	539 10 57-44	1	Decal, Belt Danger	
3	590 79 95-01	1	Decal, Bypass Release	
4	539 10 57-45	1	Decal, Battery Warning	
5	581 72 44-01	1	Decal, Deflector Warning	
6	591 18 22-01	1	Decal, Fuse	
7	591 18 21-01	1	Decal, Service	
8	593 36 76-01	1	Decal, Starting	
9	590 64 46-01	1	Decal, Belt Routing	
10	581 72 43-01	2	Decal, No Step	
11	590 79 98-01	1	Decal, Logo	
12	590 79 94-01	1	Decal, Deck Height	
13	590 80 54-01	1	Decal, V 548	
14	539 10 18-81	1	Decal, Exhaust Warning	
15	532 42 86-77	1	Decal, Crown H	
16	590 79 96-01	1	Decal, Console	

Manufacturing Number

The machine's manufacturing number can be found on the printed plate affixed to the engine compartment.

Stated on the plate, from the top are:

- The machine's type designation (I.D.)
- The manufacturer's type number (Model)
- The machine's serial number (Serial no.)

Please have the type designation and serial number available when ordering spare parts.

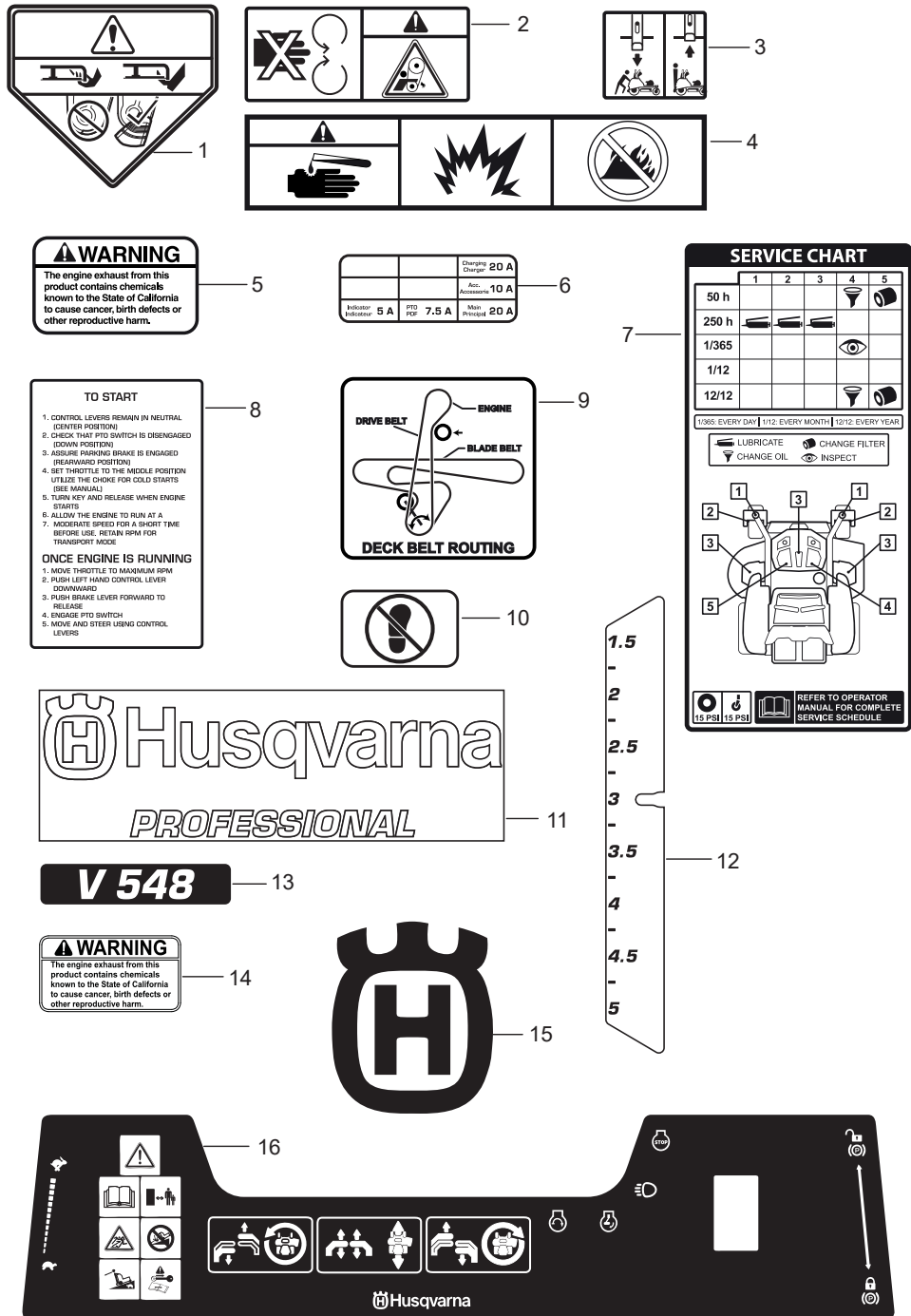

CHASSIS UPPER 4

CHASSIS LOWER..... 6

ENGINE MOUNTING, GUARDS & MUFFLER 8

STEERING 10

CONSOLE 12

FUEL SYSTEM..... 14

PARKING BRAKE 16

HYDRAULIC PUMP - MOTOR..... 18

BELT GUARD & PULLEY..... 20

WHEELS & TIRES 22

MOWER LIFT / DECK LIFT..... 24

MOWER DECK / CUTTING DECK 26

SPINDLE 28

DECALS 30

Illustrations may or may not represent the actual assemblies and it is not recommended to use this manual as a guide to assemble or disassemble the mower.

NOTE: All fasteners are Grade 5 unless otherwise specified.

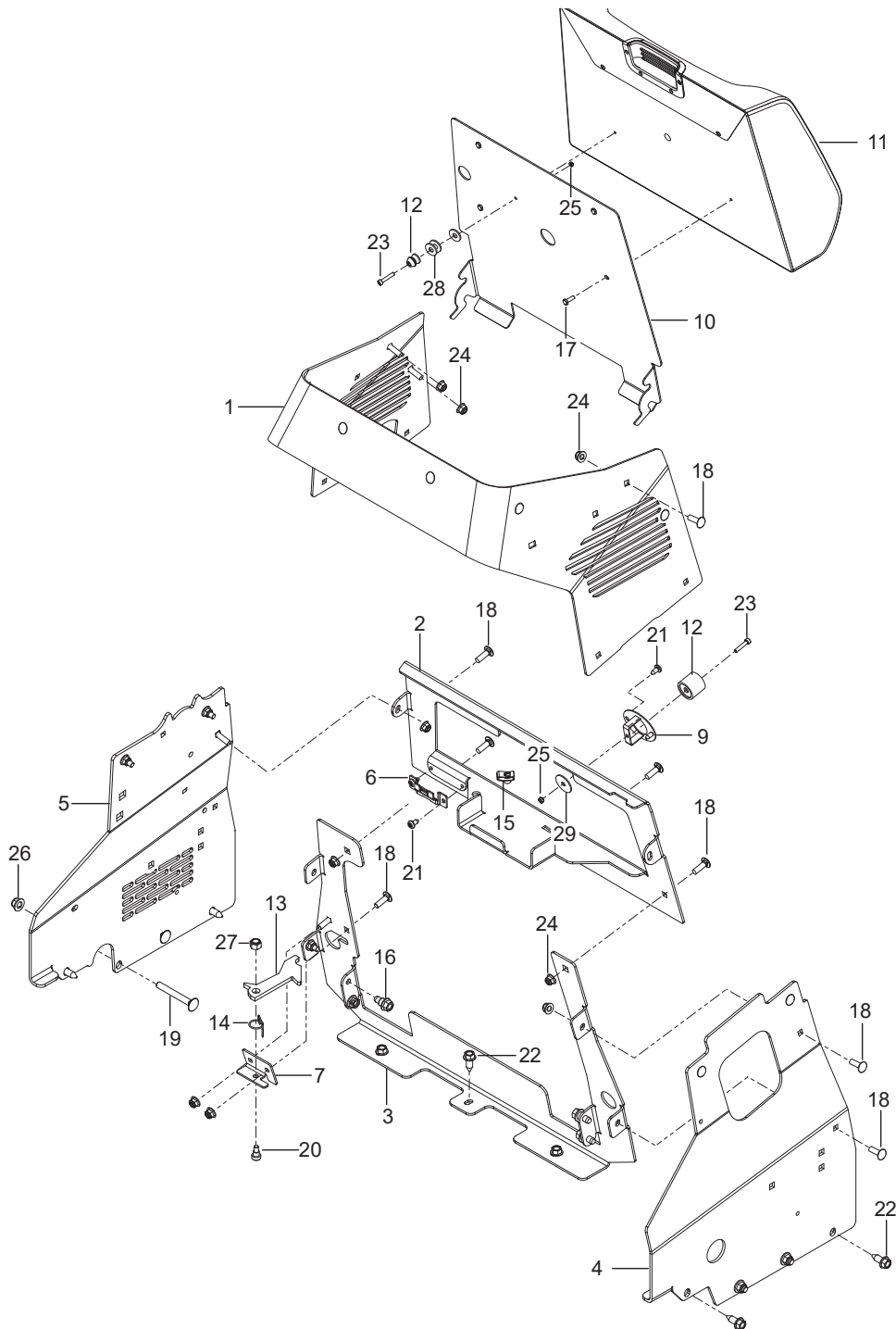

Ref.	Part No.	Qty	Description	Kit / Assy Includes
1	580 94 22-01	3	Hub	
2	580 94 21-01	3	Shaft, Spindle	
3	580 94 27-01	6	Seal, V Ring	
4	580 94 26-01	6	Seal, Shaft	
5	583 91 11-01	3	Kit, Bearing	3, 4
6	580 94 23-01	3	Spacer	
7	580 94 25-01	3	Carrier, Seal	
8	539 97 69-98	3	Zerk	
9	539 97 73-26	3	Valve, Grease Poppet	
10	539 13 06-53	3	Nut 3/4-16 Hex Flange	
NOT SHOWN				
	574 75 42-01	1	Kit, Bearing Press Tool When replacing the Spindle bearings, also order the Bearing Press Tool to assure proper installation	

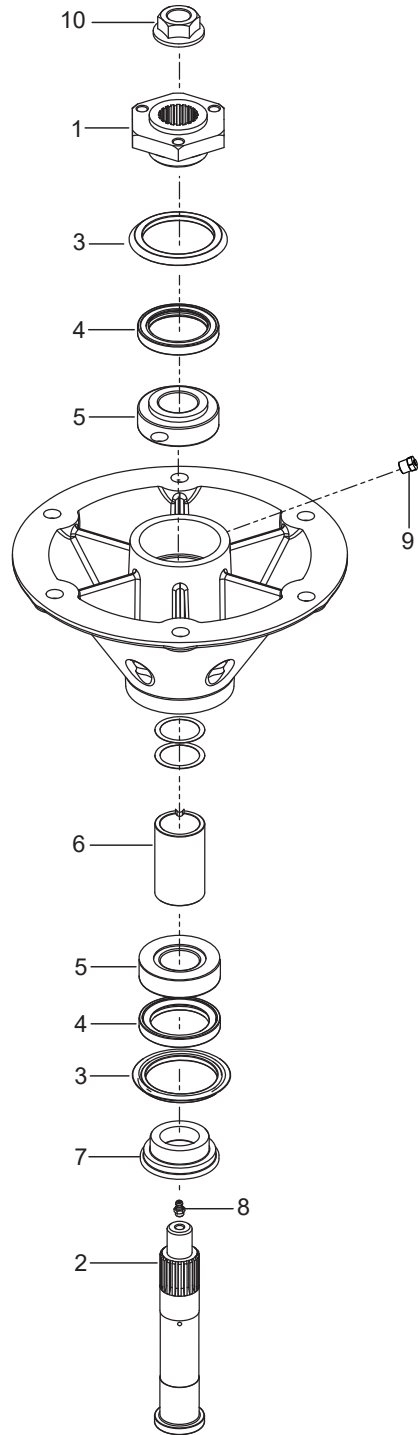

Ref.	Part No.	Qty	Description	Kit / Assy Includes
1	501 86 31-02	1	Column, Front	
2	590 74 24-06	1	Column, Rear Lower	
3	590 74 25-06	1	Column, Rear Upper	
4	501 86 34-02	1	Column, Side Left	
5	501 86 33-02	1	Column, Side Right	
6	589 50 07-02	1	Bracket, Fuse	
7	590 78 33-05	1	Bracket, Platform	
8	532 14 50-06	3	Clip	
9	592 85 78-01	1	Cradle, Holdback	
10	590 74 26-06	1	Door, Column	
11	590 78 30-01	1	Pad, Operator	
12	582 46 17-01	1	Assembly, Holder	
13	590 78 35-05	1	Latch, Platform	
14	590 79 04-01	1	Spring, Platform	
15	539 10 47-63	1	Retainer 5/16-18 U Type	
16	532 19 65-39	5	Bolt 3/8-16 Hex Flange Shoulder	
17	592 85 81-01	4	Bolt 5/16 x 5/8 w/ Loctite	
18	539 10 72-71	18	Bolt 5/16-18 x 1 Round Head Square Neck	
19	539 12 27-28	4	Bolt 3/8-16 x 3 Round Head Square Neck	
20	539 11 36-21	1	Bolt 3/8-16 Shoulder	
21	532 19 98-55	4	Screw 1/4-20 Panhead	
22	817 00 06-16	7	Screw 3/8-16 x 1 Tap Blk	
23	593 16 74-01	2	Screw Hex Head	
24	539 11 28-99	25	Nut 5/16-18 Hex Flange Nyloc	
25	593 16 73-01	2	Nut M5 Lock	
26	521 99 65-01	4	Nut 3/8-16 Hex Flange Nyloc	
27	539 97 69-79	1	Nut 3/8-16 Hex Nyloc	
28	593 17 51-01	3	Washer	
29	590 68 60-01	1	Washer 1/4 x 1-1/2	

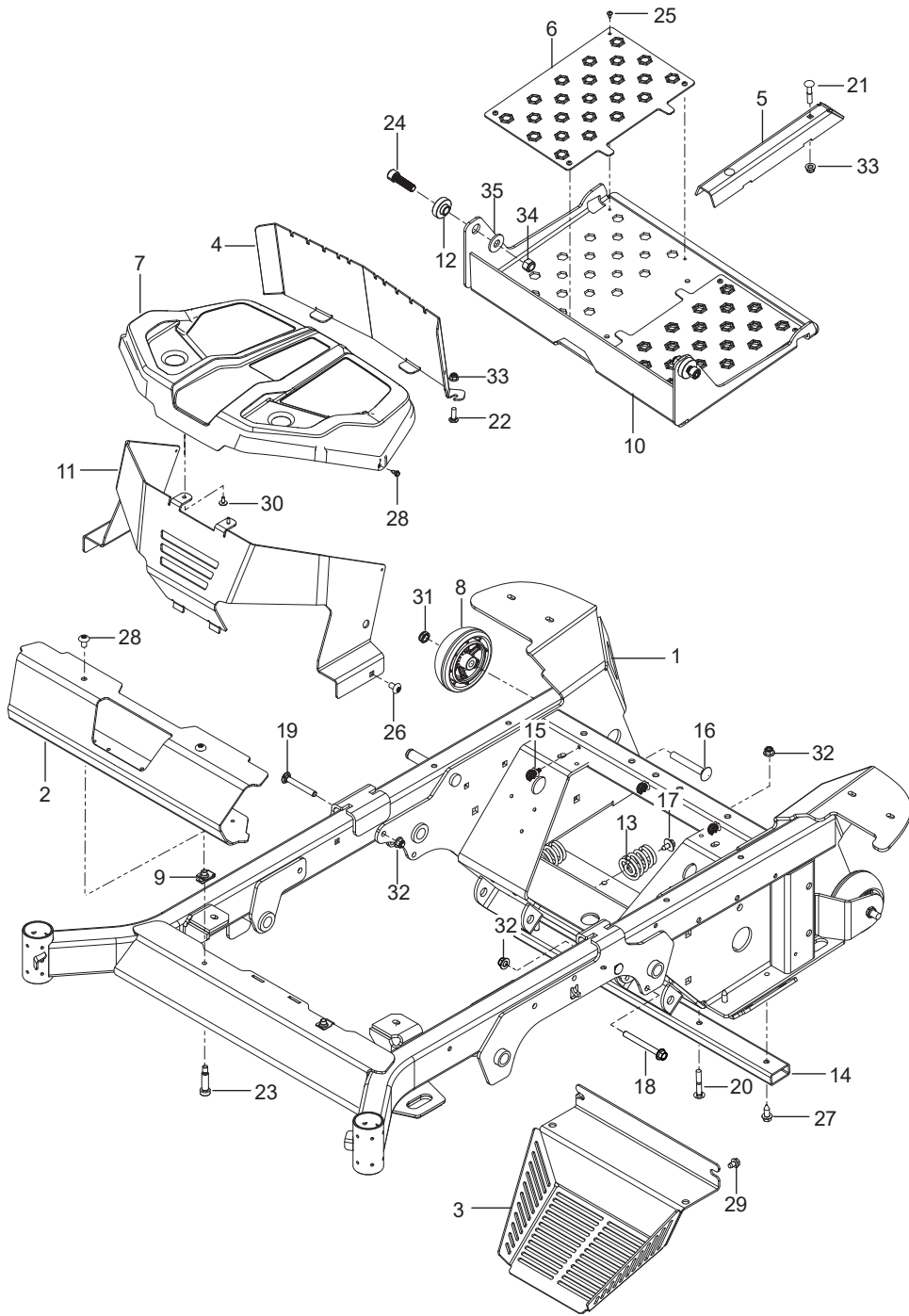

Ref.	Part No.	Qty	Description	Kit / Assy Includes
1	593 12 56-03	1	Deck 48" w/ Safety Decals	
2	590 19 28-01	1	Belt, Deck 48"	
3	592 87 35-01	1	Belt, Deck Drive	
4	589 35 34-02	3	Blade 16-1/2"	
5	539 13 06-46	3	Pulley	
6	590 54 24-01	1	Pulley Idler Flat 3"	
7	590 54 25-01	1	Pulley Idler Flat 4"	
8	589 59 57-01	1	Pulley, Stacked	
9	580 94 33-06	3	Spindle, Cast Iron	
10	593 65 09-01	1	Assembly, Tensioner Arm w/ Bearings	13
11	593 65 10-02	1	Assembly, Arm Left w/ Bearings	14
12	593 65 10-03	1	Assembly, Arm Right w/ Bearings	14
13	501 60 37-06	2	Bearing 3/8 Flange	
14	501 60 37-05	4	Bearing 1-1/2 Flange	
15	590 02 82-02	1	Bracket, Cover Left	
16	590 02 80-02	1	Bracket, Cover Right	
17	589 41 81-03	1	Bracket, Deflector Lower	
18	589 41 82-03	1	Bracket Pnt Deflector Upper	
19	590 02 81-02	1	Cover, Pulley Left	
20	590 02 83-02	1	Cover, Pulley Right	
21	592 79 74-01	1	Deflector, Deck	
22	539 10 44-11	2	Knob W/ Stud	
23	574 16 96-01	3	Roller, Gauge	
24	590 18 53-01	1	Spacer, Arm	
25	590 32 52-01	4	Spacer, Bearing	
26	590 18 54-01	1	Spacer, Pulley	
27	590 18 55-01	1	Spacer, Pulley	
28	539 10 68-50	1	Spring	
29	574 19 64-01	1	Tube, Roller Axle	
30	574 19 65-01	1	Tube, Roller Axle Long	
31	590 32 53-01	2	Tube, Spacer	
32	539 10 47-63	2	Retainer-U Type 5/16-18 Nut	
33	539 11 90-07	3	Bolt/Washer, Blade	
34	525 83 42-01	2	Bolt 3/8-16 x 1-1/2 Hex Flange Head	
35	574 21 06-01	18	Bolt 1/2-13 x 1 Hex Flange Head	
36	539 13 03-15	9	Bolt 5/16-18 x 1/2 Hex Head	
37	590 67 87-01	2	Bolt 5/8-11 x 6 Hex Head Grade 8	
38	580 75 46-01	2	Bolt 5/8-11 x 3-1/2 Hex Head	
39	874 78 06-36	1	Bolt 3/8-16 x 2-1/4 Hex Head	
40	510 02 23-01	1	Bolt 1/2-13 x 4-3/4 Round Hd Square Neck	
41	872 14 08-64	1	Bolt 1/2-13 x 8 Round Head Square Neck	
42	539 99 09-23	1	Bolt 3/8-16 x 1-3/4 Round Hd Square Neck	
43	872 14 06-10	3	Bolt 3/8-16 x 1-1/4 Round Hd Square Neck	
44	590 67 86-01	1	Bolt 3/8-16 x 4-1/4	
45	539 11 55-74	1	Bolt Eye 5/16 x 3-1/2	
46	532 19 65-39	4	Bolt Shoulder	
47	525 82 91-01	4	Nut 5/8-11 Hex Flange Nyloc	
48	521 99 11-01	2	Nut 1/2-13 Hex Flange Nyloc	
49	521 99 65-01	8	Nut 3/8-16 Hex Flange Nyloc	
50	539 11 28-99	1	Nut 5/16-18 Hex Flange Nyloc	
51	539 10 96-00	9	Washer 5/16 Disc Spring	
52	539 10 65-04	2	Washer 1-3/4 Harden	
53	819 21 21-13	2	Washer 13 Gauge	

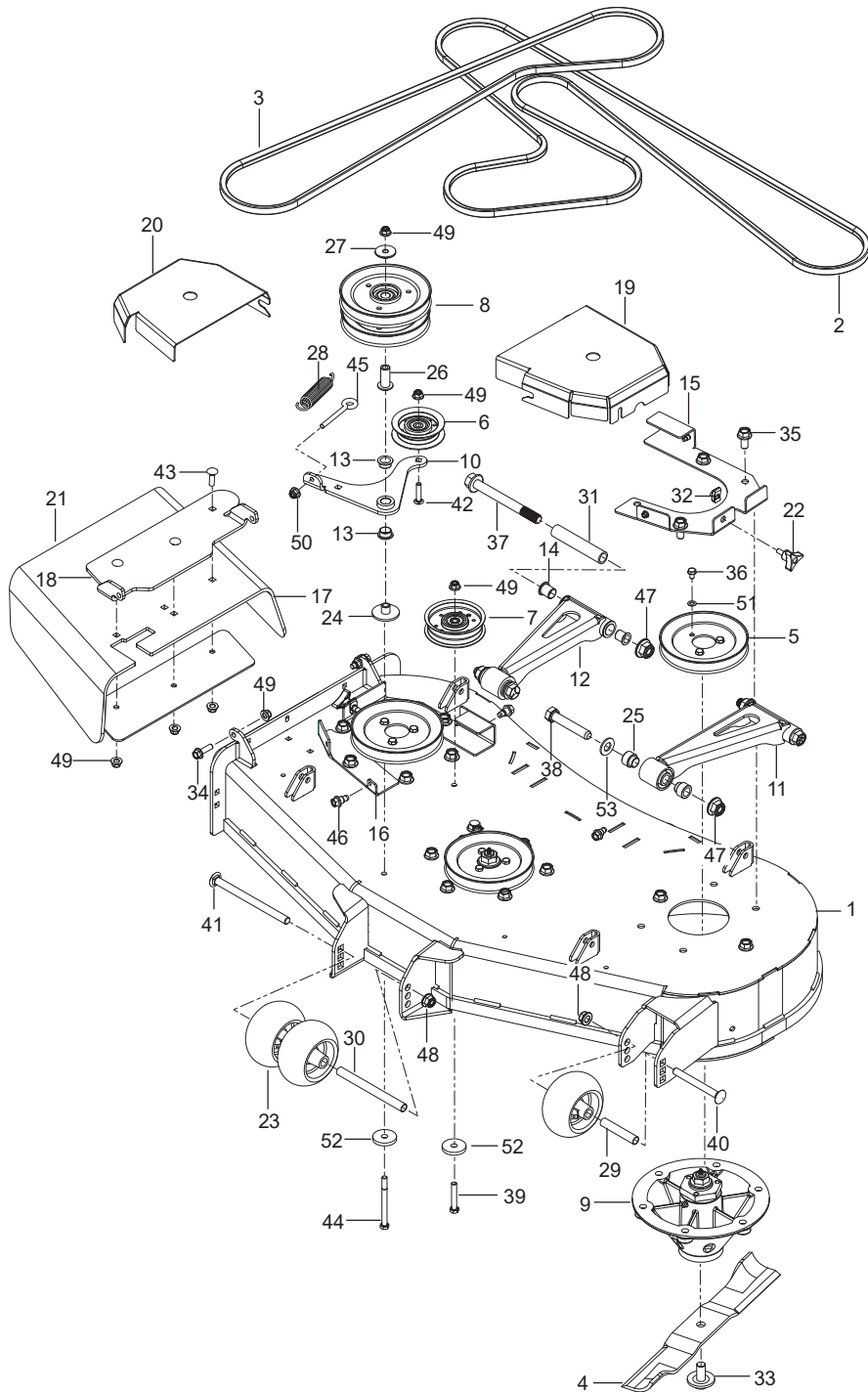

Ref.	Part No.	Qty	Description	Kit / Assy Includes
1	590 78 27-02	1	Chassis	
2	590 74 31-06	1	Cover, Front	
3	590 74 27-02	1	Cover, PTO	
4	590 91 53-02	1	Plate, Baffle	
5	590 74 30-06	1	Bracket, Angle	
6	590 78 29-02	2	Plate, Foot	
7	589 62 32-01	1	Cover, Pump	
8	589 52 74-01	2	Wheel, Gauge	
9	589 80 68-01	2	Retainer 3/8-16 U-Type	
10	590 74 29-06	1	Plate, Operator	
11	590 81 30-03	1	Shroud, Pump	
12	586 70 17-01	2	Spacer	
13	589 48 35-01	4	Spring, Tapered	
14	590 78 23-02	1	Tube, Skidplate	
15	592 85 74-01	3	Clip, Cable	
16	592 85 80-01	2	Bolt 1/2-13 x 3-1/2 Round Hd Square Neck	
17	532 17 18-77	4	Bolt 5/16-18 x 3/4 Flange Head Serated Blk	
18	874 49 06-52	2	Bolt 3/8-16 x 3-1/2 Hex Flange Head	
19	539 12 27-28	2	Bolt 3/8-16 x 3 Round Head Square Neck	
20	872 11 06-18	2	Bolt 3/8-16 x 2-1/4 Round Hd Square Neck	
21	872 11 05-14	2	Bolt 5/16 x 18 x 1-3/4 Round Hd Sq Neck	
22	872 11 05-08	2	Bolt 5/16-18 x 1 Round Hd Square Neck	
23	592 80 76-01	2	Bolt Shoulder 3/8-16	
24	592 85 79-01	2	Bolt 1/2-13 Hex Nyloc Ring	
25	592 85 84-01	8	Screw 10-24 x 3/8 Tap Torx	
26	592 85 82-01	4	Screw 3/8 Torx Thread Roll	
27	817 00 06-16	4	Screw 3/8-16 x 1 Tap Blk	
28	532 18 44-71	2	Screw Shoulder 10/24	
29	539 99 08-58	2	Screw 5/16-18 x 1/2 Thread Roll	
30	532 42 17-56	2	Screw #10	
31	521 99 11-01	2	Nut 1/2-13 Hex Flange Nyloc	
32	521 99 65-01	7	Nut 3/8-16 Hex Flange Nyloc	
33	539 11 28-99	4	Nut 5/16-18 Hex Flange Nyloc	
34	539 10 13-31	2	Nut 1/2-13 Hex Nyloc	
35	539 10 95-54	2	Washer 1/2 Flat	

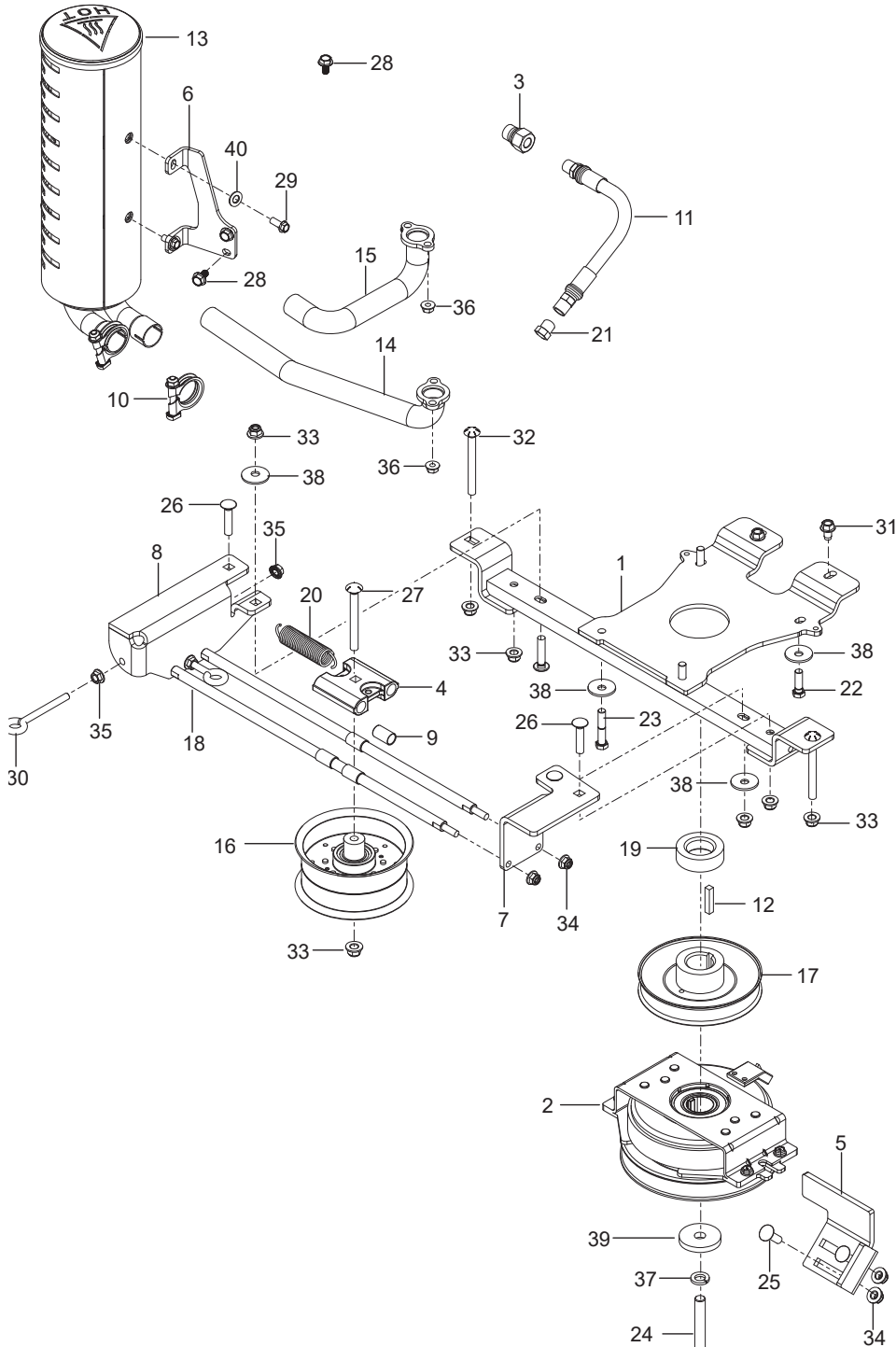

Ref.	Part No.	Qty	Description	Kit / Assy Includes
1	590 89 78-02	1	Latch, Transport	
2	593 64 38-01	1	Assembly, Release Lever	8, 23, 41, 42, 51
3	589 66 51-02	1	Plate, Height Select	
4	593 63 41-02	2	Plate, Pillow Block	
5	590 19 78-02	1	Shaft, Deck Lift	
6	590 67 30-02	1	Bracket, Spring Left	
7	590 67 29-02	1	Bracket, Spring Right	
8	591 04 21-01	2	Bushing	
9	590 86 65-01	2	Bushing Nylon 1 x 3/4"	
10	589 41 41-01	8	Bushing, Pivot Inside	
11	589 41 42-01	4	Bushing, Pivot Outside	
12	576 47 90-01	4	Eyebolt 1/2-13 x 6-3/4	
13	539 10 74-84	2	Eyebolt 3/8-16 x 1-3/4	
14	501 60 37-02	8	Bearing, Flange 1"	
15	501 60 37-03	8	Bearing, Flange 7/8"	
16	501 60 37-04	6	Bearing, Flange 5/8"	
17	539 13 15-18	2	Bearing, Flange	
18	590 00 32-01	2	Spring, Extension	
19	593 65 07-02	2	Assembly, Rear Bellcrank w/ Bearings	14, 15, 16
20	593 65 07-01	2	Assembly, Front Bellcrank w/ Bearings	14, 15, 16
21	510 02 39-02	4	Block, Pillow	
22	592 72 39-01	1	Grip, Lift Handle	
23	591 04 19-01	1	Grip, Transport	
24	593 64 37-01	1	Assembly, Lift Handle w/ Grip Slvr	22
25	593 64 39-01	2	Assembly, Deck Lift Linkage w/ Bearing	9
26	590 86 64-01	2	Pin 1/2 x 1 Clevis	
27	539 97 69-89	6	Pin 2-1/2 Hair	
28	590 46 55-01	1	Pin 3-1/2 Height Adjust	
29	589 41 43-01	4	Pin, Trunnion	
30	590 67 33-01	5	Ring E-Clip 7/8"	
31	590 00 29-01	1	Ring E-Clip 3/4"	
32	576 48 58-01	4	Spacer, Eyebolt	
33	590 00 35-02	2	Spacer, Pivot	
34	510 36 25-01	4	Spacer, Strut	
35	590 66 24-01	1	Strap	
36	589 41 44-01	2	Rod, Deck Lift	
37	592 80 77-01	2	Bolt 5 8-11 x 2-1/2 Button Hd Torx	
38	590 67 87-01	4	Bolt 5/8-11 x 6 Grade 8	
39	592 80 80-01	2	Bolt 1/2-13 x 1-1/4 Round Hd Square Neck	
40	592 80 79-01	2	Bolt 1/2-13 x 2 Round Hd Square Neck	
41	539 99 06-45	6	Bolt 3/8-16 x 1 Round Hd Square Neck	
42	592 80 76-01	1	Bolt 3/8-16 x 2 Shoulder Socket Hd	
43	592 80 78-01	2	Bolt 1/4-20 x 3/4 Round Hd Sq Short Neck	
44	592 85 91-01	4	Bolt 3/8-16 x 3-1/2 Round Hd Square Neck	
45	539 99 08-58	1	Screw 5/16-18 x 1/2 Thread Roll	
46	817 49 06-10	1	Screw 3/8-16 x 5/8 Hex Washer Hd	
47	525 82 91-01	4	Nut 5/8-11 Hex Flange Nyloc	
48	589 67 77-01	2	Nut 5/8-11 Hex Hd Thin Nyloc	
49	592 80 82-01	2	Nut, Hexagon Socket Cap	
50	521 99 11-01	8	Nut 1/2-13 Hex Flange Nyloc	
51	521 99 65-01	15	Nut 3/8-16 Hex Flange Nyloc	

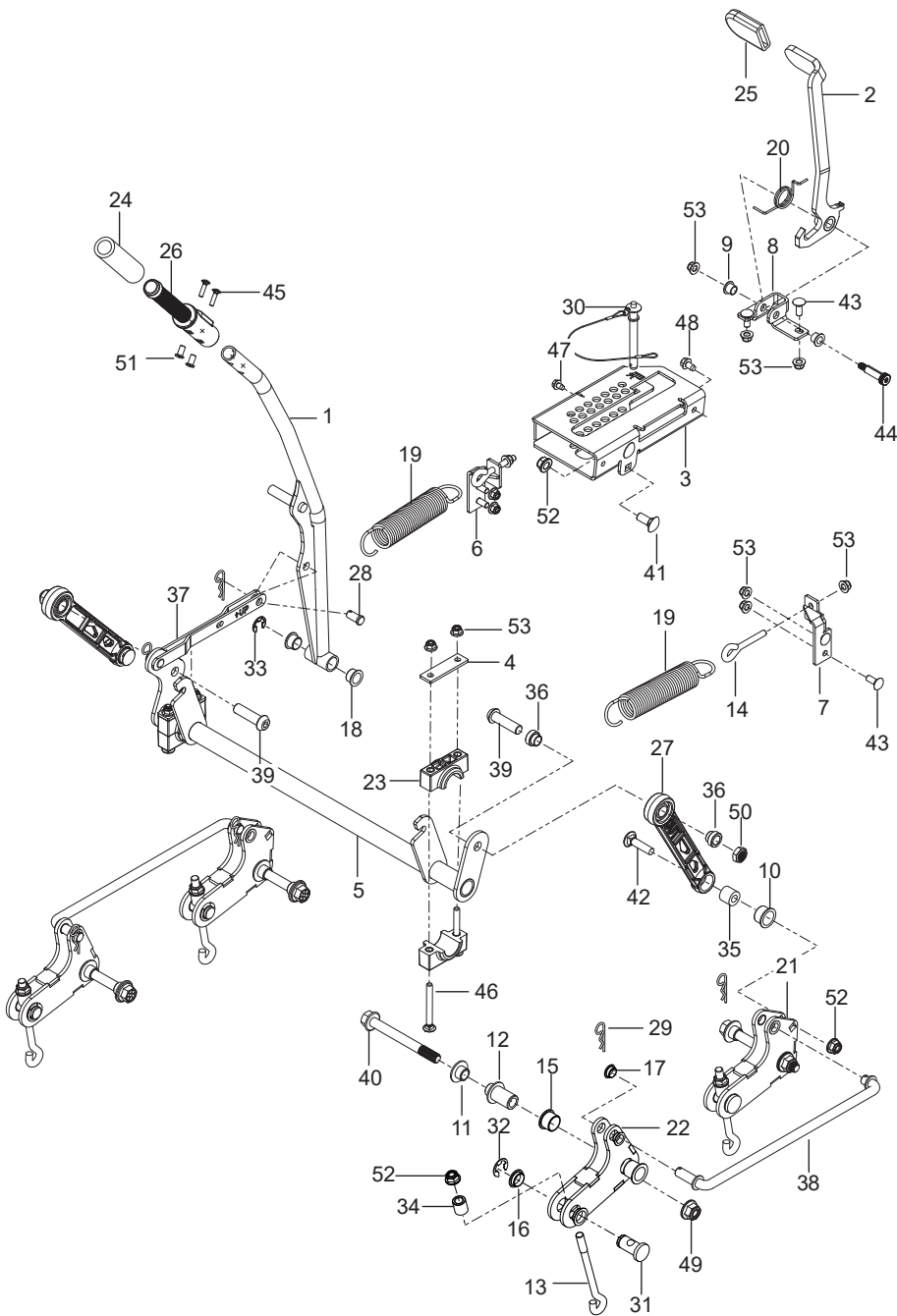

Ref.	Part No.	Qty	Description	Kit / Assy Includes
1	590 81 29-02	1	Plate, Engine	
2	589 41 46-01	1	Clutch, Ogura GT2	
3	522 59 90-01	1	Adapter, Oil Drain	
4	590 63 56-01	1	Block, Tensioner	
5	589 60 46-02	1	Bracket, Clutch	
6	590 90 74-02	1	Bracket Muffler Mount	
7	589 80 73-02	1	Bracket, Tensioner Left	
8	589 80 74-02	1	Bracket, Tensioner Right	
9	590 64 68-01	4	Bushing, Sleeve	
10	596 03 81-01	2	Clamp, Muffler	
11	584 82 55-01	1	Assembly, Hose	
12	539 91 27-57	1	Key, Sq 1/4 x 1-1/4	
13	589 72 16-01	1	Muffler, Vertical	
14	589 72 10-01	1	Tube, Muffler Left	
15	589 72 11-01	1	Tube, Muffler Right	
16	589 60 38-01	1	Pulley, Flat Idler	
17	510 01 98-01	1	Pulley, Engine	
18	589 81 36-01	2	Shaft, Tensioner	
19	590 68 06-01	1	Spacer, Engine Pulley	
20	589 80 75-01	1	Spring	
21	585 80 71-01	1	Plug, Oil	
22	874 78 06-20	2	Bolt 3/8-16 x 1-1/4 Hex Head	
23	874 78 06-32	2	Bolt 3/8-16 x 2 Hex Head	
24	581 33 28-02	1	Bolt 7/16-20 x 2-1/2 Hex Head	
25	539 99 02-08	2	Bolt 5/16-18 x 1 Round Hd Square Neck	
26	872 11 06-14	4	Bolt 3/8-16 x 1-3/4 Round Hd Square Neck	
27	872 14 06-28	1	Bolt 3/8-16 x 3-1/2 Round Hd Square Neck	
28	590 00 33-01	3	Bolt M8 x 1-1/4 x 16 Serrated Flange	
29	592 85 87-01	2	Bolt 5/16-18 x 3/4 Hex FlangeHead	
30	539 11 55-74	2	Bolt Eye 5/16 x 3-1/2	
31	817 00 06-16	2	Screw 3/8-16 x 1 Tap Blk	
32	589 39 86-02	2	Screw 3/8-16 x 3-3/5 Round Hd	
33	521 99 65-01	10	Nut 3/8-16 Hex Flange Nyloc	
34	539 11 28-99	6	Nut 5/16-18 Hex Flange Nyloc	
35	539 99 05-85	4	Nut 5/16-18 Hex Whizlock	
36	532 18 43-62	4	Nut M8 x 1.25 Hex Flange Toplock	
37	539 99 02-47	1	Washer 7/16 Slotted Lock	
38	539 91 20-63	6	Washer, Cone	
39	539 10 65-04	1	Washer, Hardened	
40	539 10 25-93	2	Washer, 3/8 Spring	
NOT SHOWN				
592 96 47-01	1	Harness, Clutch		
586 83 97-01	2	Gasket, Exhaust		
Engine, Kawasaki FX751V 18.3 kW (24.5 hp) For engine replacement parts, see a Kawasaki dealer				

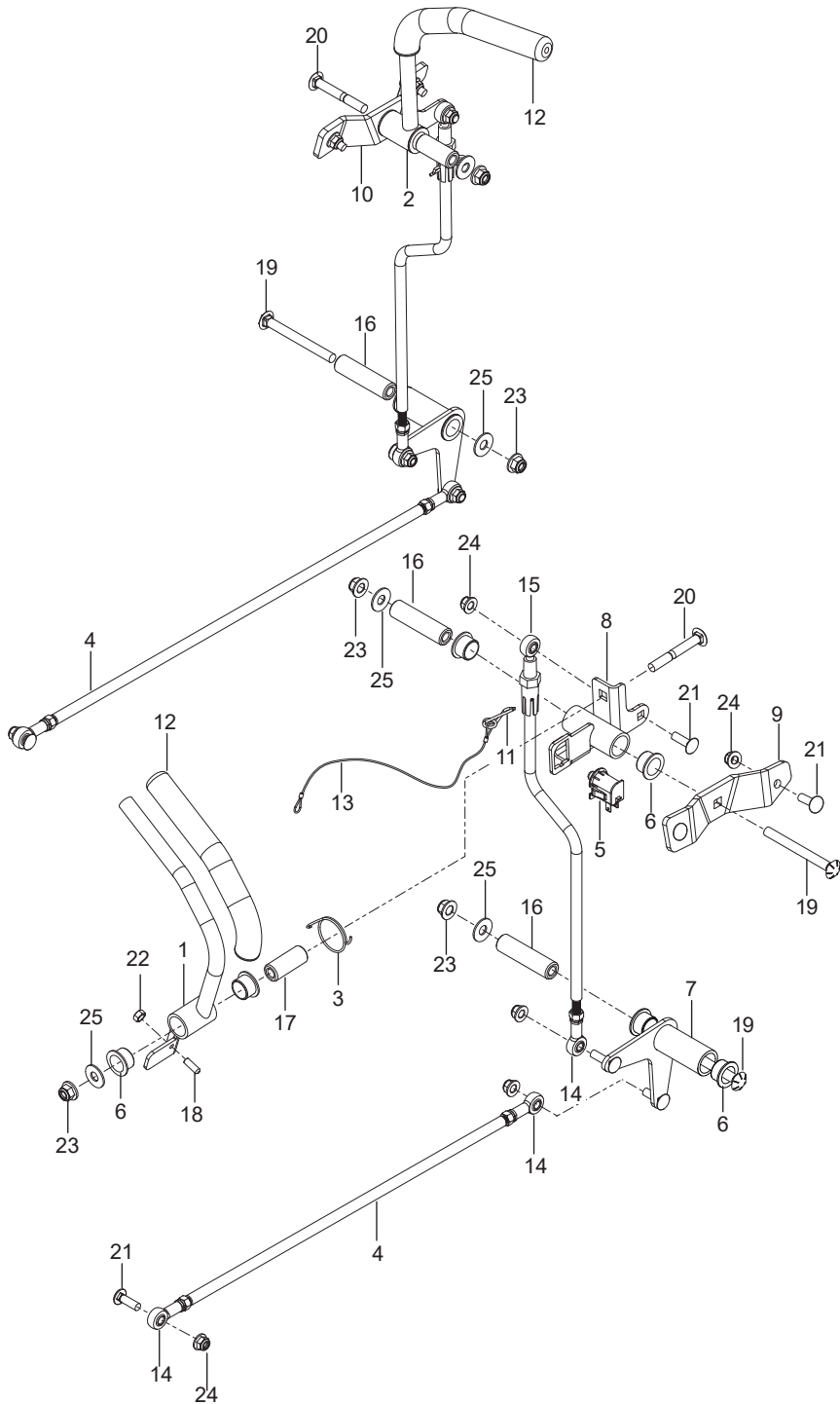

Ref.	Part No.	Qty	Description	Kit / Assy Includes
1	590 70 48-01	2	Assembly, Wheel 20 x 10-10 Rear	
2	581 19 95-01	2	Wheel, Caster 13 x 6.50 Front	
3	590 70 00-01	2	Cap, Dust	
4	591 42 51-01	2	Cap, Spring	
5	590 67 46-02	2	Fork, Caster Org	
6	590 68 16-01	2	Spring, Wave	
7	539 10 28-51	2	Seal	
8	575 33 49-01	2	Spacer, Pivot	
9	539 10 25-43	4	Bearing	
10	539 10 14-74	2	Zerk	
11	539 10 55-17	2	Bolt 1/2-13 x 9-1/2	
12	591 45 73-01	2	Screw 7/16-14 x 1 Socket Button Head	
13	587 65 39-02	8	Nut 1/2-20 Grd 8	
14	521 99 11-01	2	Nut 1/2-13 Hex Flange Nyloc	
15	819 18 22-12	2	Washer 9/16 x 1 3/8 X 12	

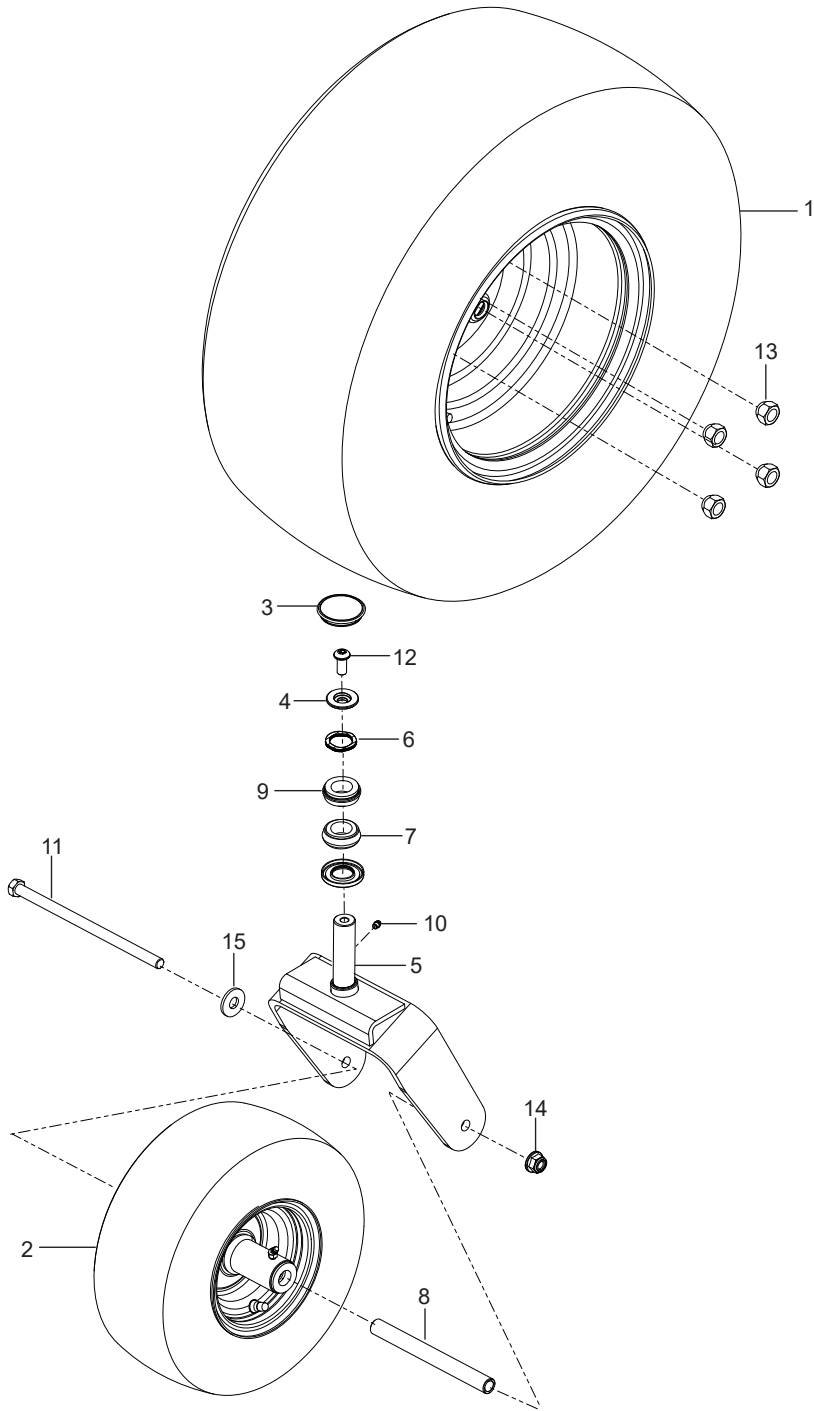

Ref.	Part No.	Qty	Description	Kit / Assy Includes
1	596 53 18-01	1	Assembly, Control Lever Left	4, 5, 10, 16, 18, 20, 21, 23
2	596 51 77-01	1	Assembly, Lever Right	5, 10
3	582 68 79-01	2	Linkage, Control	
4	532 42 10-62	1	Switch, NC	
5	539 13 15-18	10	Bearing, Flange	
6	596 51 78-01	2	Assembly, Bellcrank Blk	5
7	590 60 01-02	1	Bracket, Pivot Left	
8	590 60 00-02	1	Bracket, Pivot Right	
9	582 55 19-01	2	Clip, Retainer	
10	590 62 39-01	2	Grip	
11	539 10 50-59	2	Lanyard	
12	588 69 26-01	6	Rod End, Female	
13	588 69 25-02	2	Rod End, Male	
14	582 68 73-01	3	Spacer, Pivot Long	
15	582 68 73-02	2	Spacer, Pivot Short	
16	592 72 72-01	1	Screw 1/4-20 x 3/4 Hex Set	
17	589 39 86-02	3	Bolt 3/8-16 x 3-3/4 RHSN	
18	872 11 06-22	2	Bolt 3/8-16 x 2-3/4 RHSN	
19	539 10 72-71	12	Bolt 5/16-18 x 1 RHSN	
20	873 22 04-00	1	Nut 1/4-20 Hex	
21	521 99 65-01	5	Nut 3/8-16 Hex Flange Nyloc	
22	539 11 28-99	12	Nut 5/16-18 Hex Flange Nyloc	
23	819 13 16-16	5	Washer 13/32 16 Gauge	

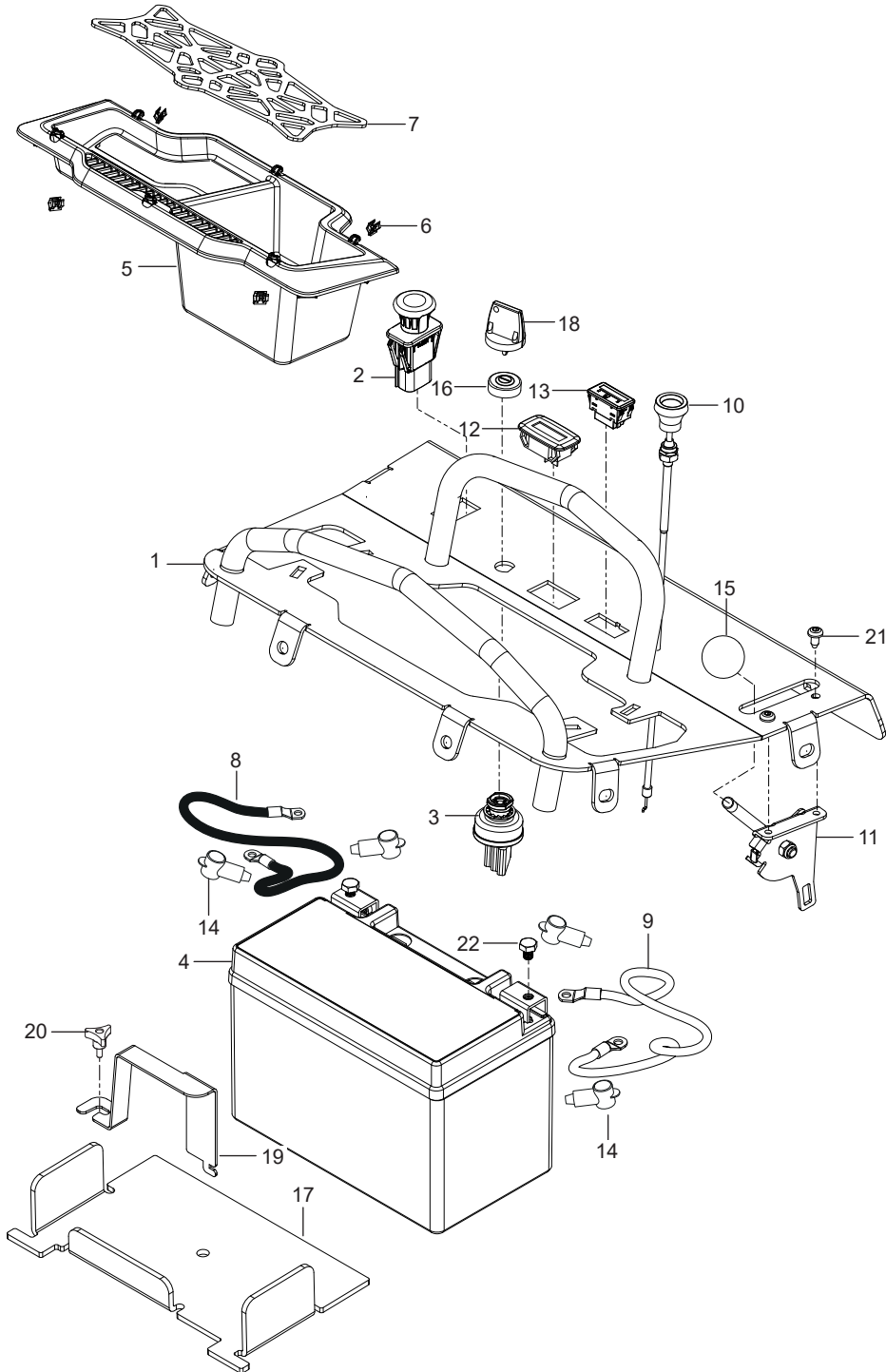

Ref.	Part No.	Qty	Description	Kit / Assy Includes
1	582 48 04-03	1	Belt	
2	589 39 83-01	2	Pulley, 5"	
3	539 97 66-88	2	Pulley, Idler	
4	577 43 72-01	1	Spring, Extension	
5	574 89 11-04	1	Arm, Idler w /Bearing	
6	574 97 56-01	1	Bushing, Pivot	
7	525 43 56-01	1	Pivot, Idler	
8	510 26 22-01	2	Shield, Dust	
9	539 11 46-62	1	Shield, Dust	
10	510 25 45-01	1	Shield, Dust	
11	539 11 55-74	1	Eyebolt 5/16 x 3-1/2	
12	525 82 89-01	1	Bolt 1/2-13 x 3 Hex Flange Head	
13	539 10 01-45	1	Bolt 3/8-16 x 2 Round Head Square Neck	
14	521 99 65-01	1	Nut 3/8-16 Hex Flange Nyloc	
15	539 99 05-85	2	Nut 5/16-18 Hex Whizlock	
16	521 99 11-01	1	Nut 1/2-13 Hex Flange Nyloc	
17	539 99 05-50	2	Washer 14 Gauge	

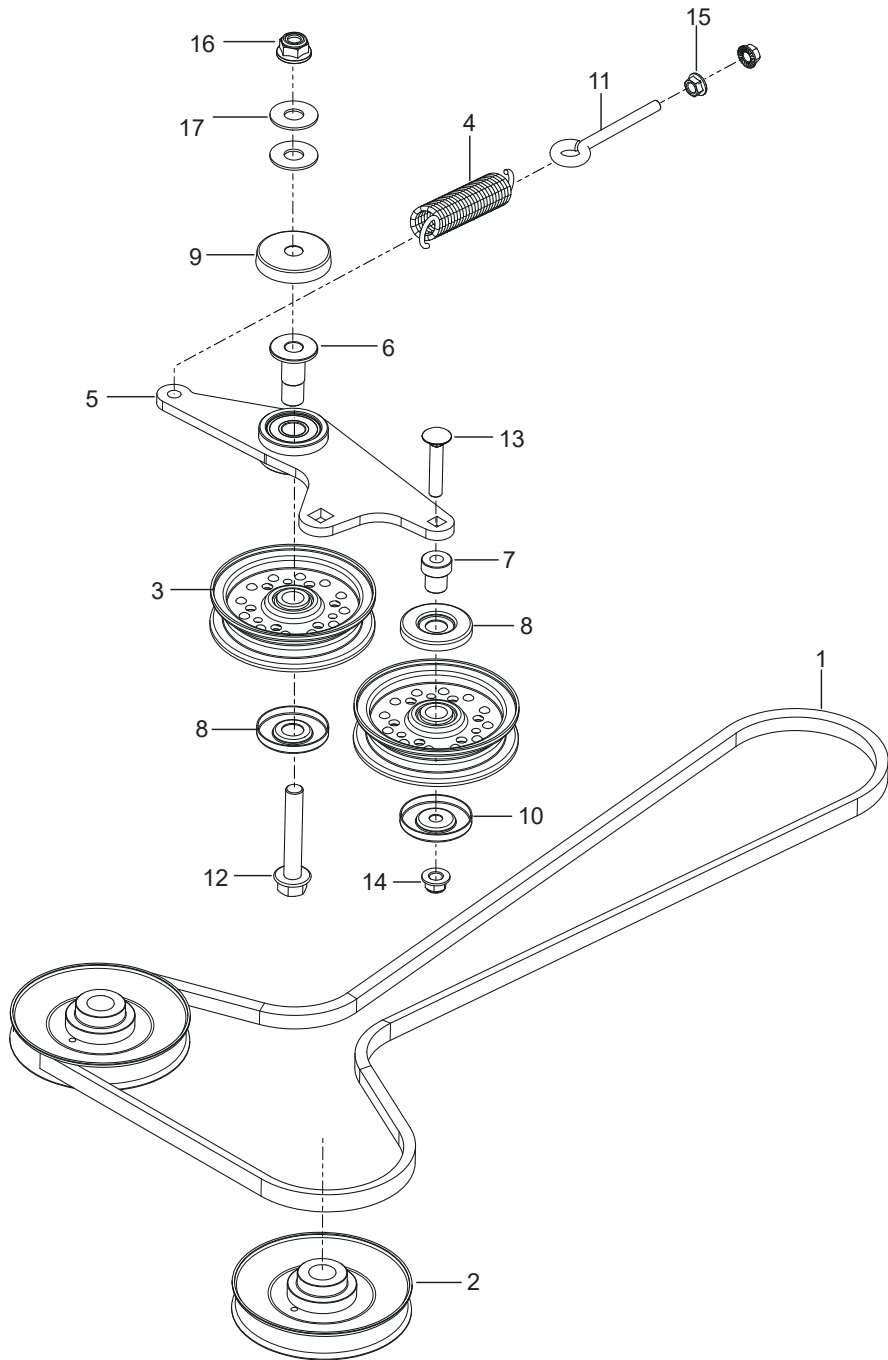

Ref.	Part No.	Qty	Description	Kit / Assy Includes
1	501 86 62-02	1	Panel, Control	
2	589 88 72-01	1	Switch, Blade	
3	574 45 54-01	1	Switch, Ignition	
4	589 81 95-01	1	Battery	
5	593 66 41-02	1	Assembly, Tray Gry	6
6	582 68 59-01	4	Clip	
7	592 84 33-02	1	Net, Cargo	
8	592 83 84-01	1	Cable, Negative	
9	592 83 83-01	1	Cable, Positive	
10	574 20 69-03	1	Cable, Choke	
11	582 68 87-01	1	Cable Throttle	
12	594 91 91-01	1	Gauge, Service	
13	592 87 27-02	1	Gauge, Fuel	
14	539 10 27-59	4	Insulator	
15	539 13 26-24	1	Knob, Shift	
16	539 10 31-78	1	Cap, Switch Blk	
17	590 57 70-01	1	Pad, Battery	
18	574 45 55-01	2	Key, Ignition	
19	590 92 76-06	1	Strap, Battery Gry	
20	539 10 44-11	1	Knob, w/ Stud	
21	532 19 98-55	2	Screw 1/4-20 Panhead	
22	582 46 08-01	2	Screw M6 x 8mm Hex Cap	
NOT SHOWN				
	593 66 42-01	1	Ignition, Assembly	3, 16, 18
	592 87 68-01	1	Harness, Main	
	589 83 85-01	1	Adapter, Harness	
	592 83 08-01	1	Jumper, Harness 42"	

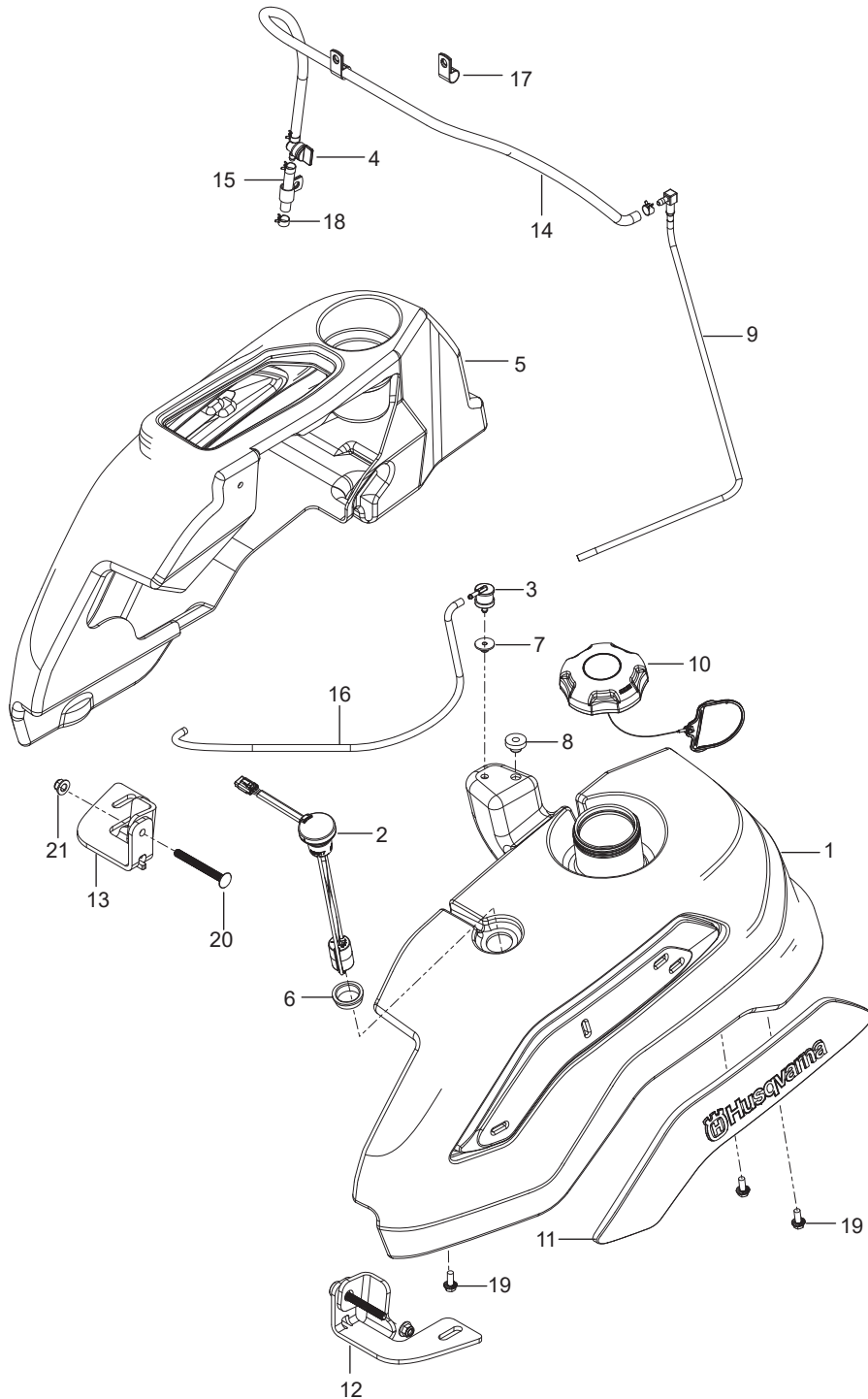

Ref.	Part No.	Qty	Description	Kit / Assy Includes
1	590 62 60-02	1	Bracket, Return Left	
	590 62 60-04	1	Bracket, Return Right	
2	582 63 59-03	1	Bracket, Mounting Left Black	
3	582 63 59-04	1	Bracket, Mounting Right Black	
4	582 64 11-02	1	Plate, Mounting Blk	
5	589 39 81-01	1	Pump 12cc Left	
6	589 39 81-02	1	Pump 12cc Right	
7	589 56 96-01	4	Spring, Return	
8	587 64 84-01	2	Switch, NC/NO	
9	589 42 18-01	1	Motor, Hydraulic Left	
10	589 42 18-02	1	Motor, Hydraulic Right	
11	539 11 39-52	2	Spring	
12	589 39 84-01	4	Fitting 45° Elbow	
13	589 39 85-01	4	Fitting 90° Elbow	
14	589 41 92-01	2	Hose, Hydraulic Lower Blk	
15	589 41 93-01	2	Hose, Hydraulic Upper Blu	
16	582 68 86-03	1	Pull, Bypass	
17	592 85 75-01	2	Clip	
18	582 68 85-03	1	Link, Pump Bypass	
19	582 68 84-03	2	Plate, Pivot	
20	593 26 04-01	1	Assembly, Speed Control Left	8, 21, 23, 34, 36, 37
	593 26 04-02	1	Assembly, Speed Control Right	8, 21, 23, 34, 36, 37
21	590 68 08-01	2	Bolt 1/4-20 x 1 Socket Head	
22	592 85 83-01	3	Bolt 1/4 x 5/16 Shoulder	
23	539 10 83-95	2	Bolt 5/16 x 2 Hex Head Tap	
24	532 16 54-92	2	Bolt 5/16-18 Shoulder	
25	539 99 06-45	6	Bolt 3/8-16 x 1 Round Head Square Neck	
26	872 11 06-20	2	Bolt 3/8-16 x 2-1/2 Round Head Square Neck	
27	582 69 25-01	4	Bolt 1/2-13 x 1-1/2 Round Head Square Neck	
28	582 69 25-02	4	Bolt 1/2-13 x 3-1/2 Round Head Square Neck	
29	589 39 86-01	2	Bolt 3/8-16 x 3-1/2 Round Head Square Neck	
30	582 68 18-01	4	Screw 1/2-20 x 1/2 Socket Head Cap	
31	582 69 23-01	8	Screw 1/2-13 x 2-1/2	
32	539 97 69-78	3	Nut 1/4-20 Hex Nyloc	
33	521 99 65-01	8	Nut 3/8-16 Hex Flange Nyloc	
34	539 99 05-85	2	Nut 5/16-18 Hex Whizlock	
35	521 99 11-01	8	Nut 1/2-13 Hex Flange Nyloc	
36	590 68 60-01	2	Washer 1-1/2	
37	810 04 04-00	2	Washer, Lock	
38	582 69 24-01	8	Washer, Lock	

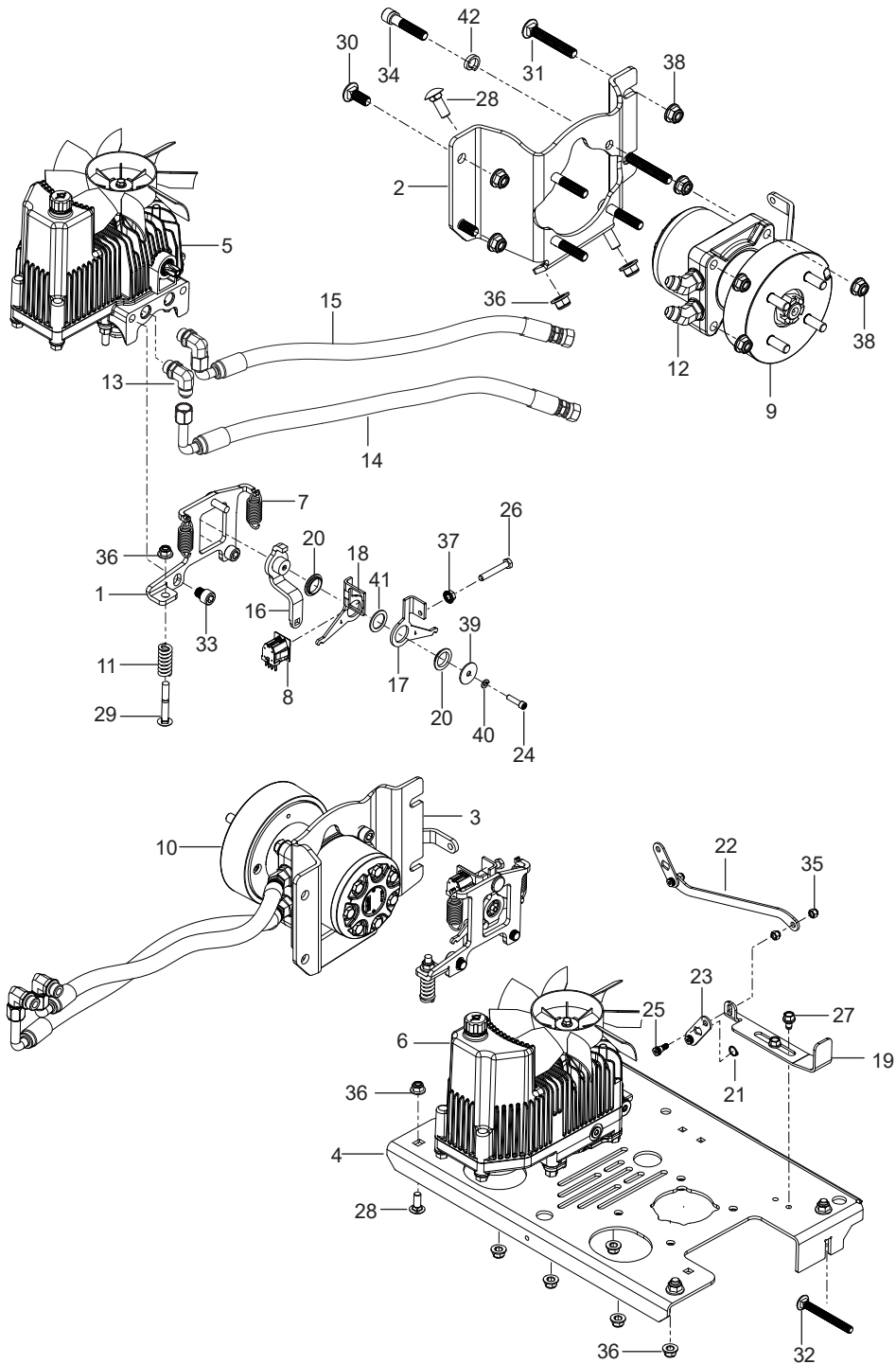

Ref.	Part No.	Qty	Description	Kit / Assy Includes
1	582 04 69-01	1	Assembly, Fuel Tank	2, 3, 6, 7, 8, 9, 10
2	590 63 88-01	1	Sensor, Fuel	
3	576 61 81-01	1	Valve, Roll Over	
4	539 91 63-25	1	Valve, Fuel	
5	582 04 73-01	1	Console	
6	590 20 91-01	1	Grommet, Fuel Sensor	
7	584 64 82-01	1	Grommet, Valve	
8	532 00 36-45	1	Grommet, Fuel	
9	582 68 81-01	1	Assembly, Fuel Tube	
10	575 01 81-01	1	Cap, Fuel	
11	582 48 34-01	1	Cover Left	
	582 48 24-01	1	Cover Right	
12	582 68 82-02	1	Bracket, Mount Left	
13	582 68 82-04	1	Bracket, Mount Right	
14	587 04 48-43	1	Hose 1/4 x 43" Fuel	
15	587 04 48-03	1	Hose 1/4 x 3" Fuel	
16	587 04 45-23	1	Hose 3/16 x 23" Vapor	
17	592 72 43-01	3	Clamp, P Type	
18	532 12 34-87	4	Clamp, Hose	
19	592 85 87-01	6	Bolt 5/16-18 x 3/4 Hex Flange Head	
20	592 85 91-01	2	Bolt 3/8-16 x 3-1/2 Round Head Square Neck	
21	521 99 65-01	2	Nut 3/8-16 Hex Flange Nyloc	

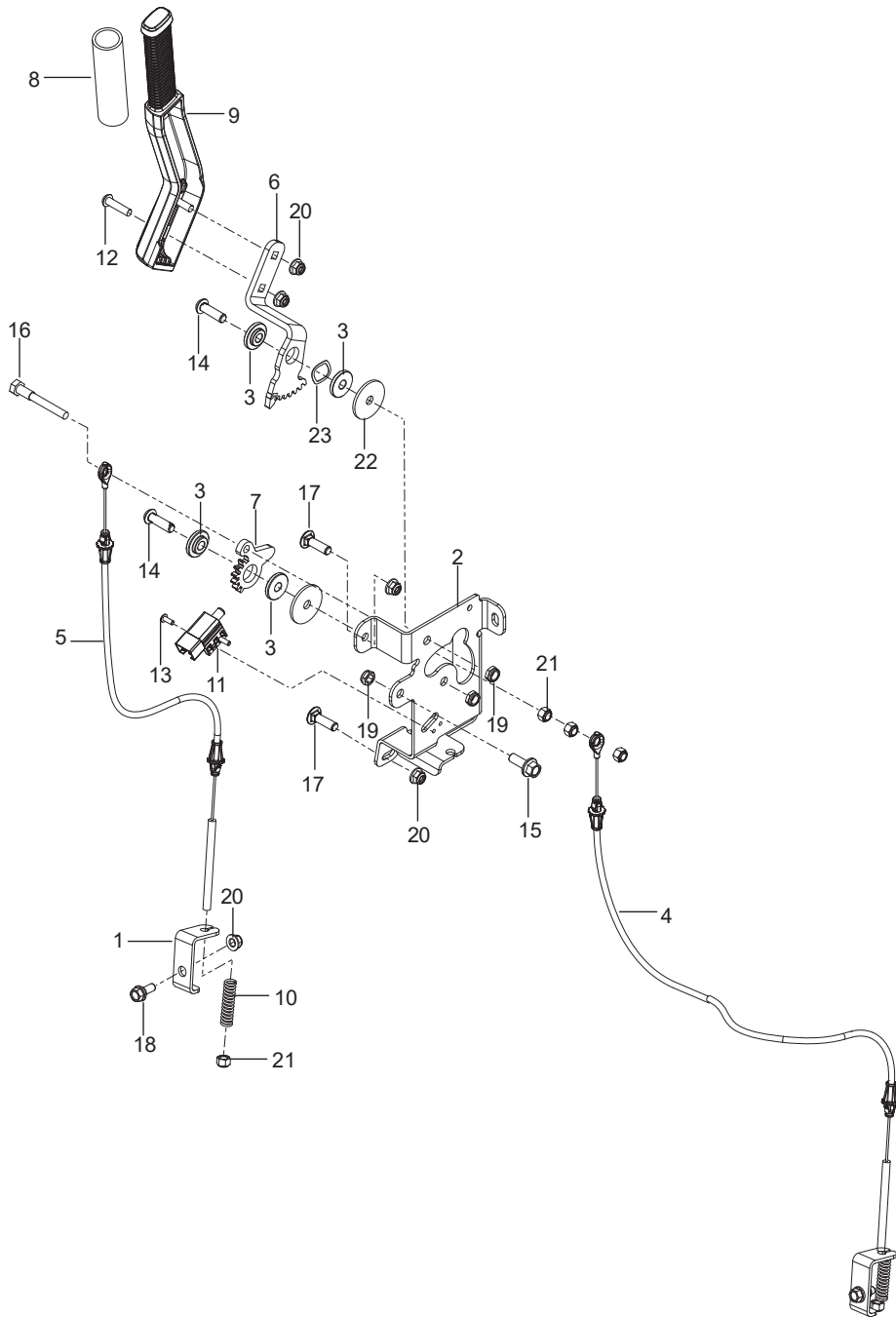

Ref.	Part No.	Qty	Description	Kit / Assy Includes
1	593 26 12-01	1	Assembly, Brake	
2	590 72 11-01	2	Bracket, Pivot	
3	590 58 66-01	1	Cable, Park Left	
4	590 58 67-01	1	Cable, Park Right	
5	592 61 93-01	1	Grip	
6	593 26 11-01	1	Assembly, Lever w/ Grip	5
7	590 87 82-01	2	Spring, Compression	
8	532 10 95-53	1	Switch, Interlock	
9	578 29 64-03	2	Screw 5/16-18 x 1-1/4 Button Head	
10	586 93 60-01	2	Screw 10-24 x 1/2 Patch Button Head	
11	525 61 28-01	1	Bolt 3/8-16 x 1 Hex Flange Head	
12	590 79 08-01	1	Bolt 5/15-18 x 2-3/4 Hex Head Shoulder	
13	539 10 72-71	2	Bolt 5/16-18 x 1 Round Head Square Neck	
14	539 11 03-03	2	Bolt 5/16 Shoulder	
15	539 20 02-82	1	Nut 3/8-16 Hex Jam Nyloc	
16	539 11 28-99	6	Nut 5/16-18 Hex Flange Nyloc	
17	539 99 07-17	5	Nut 5/16-18 Hex Nyloc	