

COLLECTION SYSTEM

Operator / Parts Manual

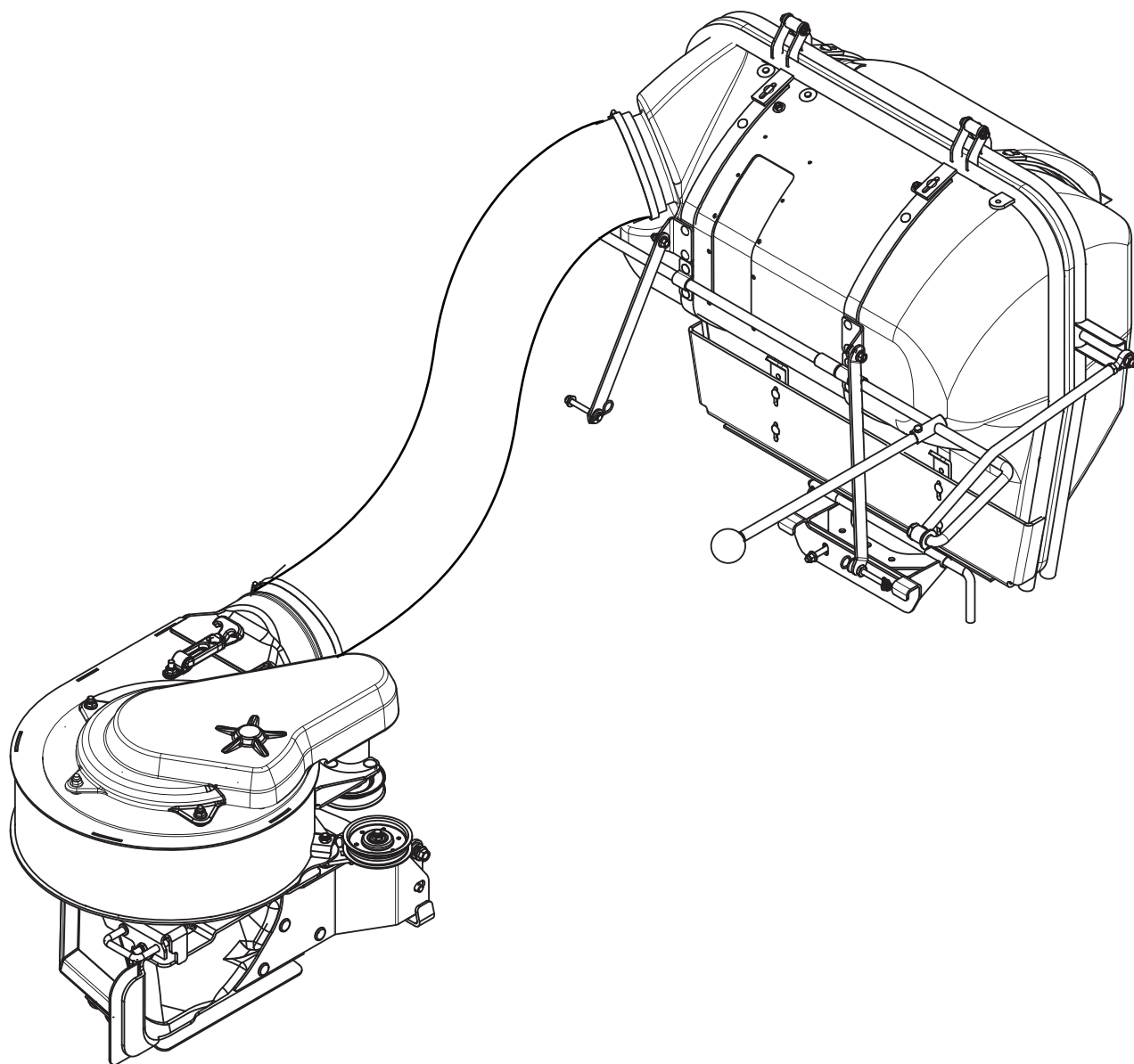

96732250 I

Dump from Seat Clamshell / 8 BU



Please read the operator manual carefully and make sure you understand the instructions before using the machine.

CONGRATULATIONS on the purchase of a new collection system. It has been designed, engineered and manufactured to give the best possible dependability and performance.

If you experience any problem you cannot easily remedy, contact your nearest authorized service center/ department. They have competent, well-trained technicians and the proper tools for service and repairs.

Please read and retain this manual. The instructions will enable you to assemble and maintain your collection system properly. Always observe the SAFETY RULES.

KNOW YOUR COLLECTION SYSTEM

READ THIS OPERATION MANUAL AND SAFETY RULES BEFORE ASSEMBLING OR OPERATING YOUR COLLECTION SYSTEM. Compare the illustrations with the carton contents to familiarize yourself with the parts before starting the assembly. Study the operating instructions and safety precautions thoroughly to insure proper functioning of your Grass Catcher and to prevent injury to yourself and others. Save this manual for future reference.

 **CAUTION!** DO NOT operate mower with grass catcher partially installed.

- Disengage blades and stop engine before leaving mower seat to empty containers, unclogging chutes, etc.
- Close cover before starting.
- Disengage mower blades when crossing driveways or gravel surfaces and other areas where thrown objects could be a hazard.
- DO NOT attempt to vacuum cans or other potentially hazardous projectiles.

 **CAUTION!** Do not leave grass in bagger containers. Empty containers after each use and before storing. Failure to do so may result in spontaneous combustion which could develop into a fire.

 **CAUTION!** Grass catcher components are subject to wear, damage and deterioration, which could expose moving parts or allow objects to be thrown. Frequently check components and replace with manufacturer's recommended parts, when necessary.

 **CAUTION!** Before assembling grass catcher to mower:

- Set parking brake.
- Place motion control levers in NEUTRAL position.
- Turn ignition key OFF and remove key.
- Make sure the blades and all moving parts have completely stopped.

 **CAUTION!** The operation of any mower can result in foreign objects thrown into the eyes, which can result in severe eye damage. ALWAYS wear safety glasses or eye shields before starting your mower and while mowing. Standard safety glasses are recommended or a wide vision safety mask for over spectacles.

CONTENTS

SAFETY.....	4
MAINTENANCE.....	5
TROUBLESHOOTING GUIDE	5
ASSEMBLY	6
REPAIR PARTS	12
BLOWER.....	12
CLAMSHELL FRONT.....	16
WEIGHTS, BAFFLES, SHIELDS.....	18

Tips For Improved Bagging

- Follow the mower operation instructions in the Operator Manual.
- When using the grass catcher on a lawn where grass and leaf bagging equipment has not been used previously, thatch and debris that has accumulated for long periods of time is picked up. The amount collected and the total time of operation may be greater than will be experienced with regular use of the grass catcher.
- Always run throttle at full speed when bagging.
- Select a ground speed low enough to give good mower cutting performance, good quality cut and good bagging performance.
NOTE: It may be necessary to overlap width of cut to suit your conditions.
- If grass is extremely tall, it should be mowed twice. The first cut should be at one of the highest settings, the second time to desired height.
- Use the left hand side of mower for trimming.
- Avoid cutting wet grass or in the morning while the dew is still heavy. Grass clippings collected under these conditions tend to be sticky and adhere to the walls of the flow path causing clogging.
- If the grass catcher fails to pick up cut grass or leaves, it is an indication that clogging has occurred in the system or that the grass catcher is full.

General Recommendations

Always observe safety rules when performing any maintenance.

- Before each use check for loose fasteners.
- Clean unit thoroughly after each use.

Blade Care

- For best results mower blades must be kept sharp. Replace bent or damaged blades.
- See instructions in the mower operator manual.

Storage

When grass catcher is to be stored for a period of time, clean it thoroughly, remove all dirt, grass, leaves, etc. Store in a clean, dry place.

Tools Required

Ratchet	Wrench ¾" (2)
Torque Wrench	Socket ¾"
Wrench ½"	Flat Screw Driver
Socket ½"	1" Wrench - open end (2)
Wrench 9/16"	Drill with 7/16" bit
Socket 9/16"	

NOTE: When right hand (RH) and left hand (LH) are mentioned in this manual, it means when you are seated on the mower in the operator's position.

SAFETY



WARNING! THIS CUTTING MACHINE IS CAPABLE OF AMPUTATING HANDS AND FEET AND THROWING OBJECTS. FAILURE TO OBSERVE THE FOLLOWING SAFETY INSTRUCTIONS COULD RESULT IN SERIOUS INJURY OR DEATH.

General Operation

- **DO NOT** operate mower with grass catcher, unless the front weights are installed. Read, understand and follow all instructions in the manual and on the machine before starting.
- Keep machine free of grass, leaves or other debris buildup which can touch hot exhaust/engine parts and burn. Do not allow the mower deck to plow leaves or other debris which can cause buildup to occur.
- Stop engine before removing grass catcher or unclogging chute.
- Do not operate the mower without either the entire grass catcher or the guard in place. Be aware of the mower discharge direction and do not direct it towards anyone.
- Clear the area of objects such as rocks, stones, toys, wire etc., which could be picked up and thrown by the blades.
- Only allow responsible adults, who are familiar with the instructions, to operate the machine.
- The owner and operator of this equipment can prevent accidents and is responsible for accidents or injuries occurring to themselves, other people and/or property.
- Be sure the area is clear of all people and pets before mowing. Stop the machine if anyone enters the area.
- Never carry passengers or children even with blades off.
- Do not mow in reverse unless absolutely necessary. Always look down and behind before and while backing.
- Slow down before turning.
- Never leave the machine unattended when the engine is running. Always turn off the blades, set the parking brake, stop the engine and remove the key before leaving the machine.
- Turn off blades when not mowing.
- Mow only in daylight or good artificial light.
- Do not operate the machine while under the influence of alcohol or drugs.
- Watch out for traffic when operating near or crossing roadways.
- Use extra care when loading and unloading the machine onto a trailer or truck.
- Data indicates that operators, age 60 years and above, are involved in a large percentage of riding mower-related injuries. These operators should evaluate their ability to operate the riding mower safely enough to protect themselves and others from serious injury.
- Clean any oil or fuel spillage before operating or storing the machine.
- Allow machine to cool before storage.

Slope Operation

Slopes are a major factor related to loss-of-control and tip-over accidents, which can result in severe injury or death. All slopes require extra caution. If you cannot back up the slope or if you feel uneasy on it, do not mow it.

DO

- Mow up and down slopes (10° Max.), not across.
- Remove obstacles such as rocks, tree limbs, etc.
- Watch for holes, ruts, or bumps. Uneven terrain could overturn the machine. **Tall grass can hide obstacles.**
- Use slow speed. Choose a low speed so that you will not have to stop while on the slope.
- Use extra care with grass catchers or other attachments. These can change the stability of the machine.
- Keep all movement on the slopes **slow** and **gradual**. Do not make sudden changes in speed or direction.
- Avoid starting or stopping on a slope. If tires lose traction, disengage the blades and proceed slowly **straight** down the slope.

DO NOT

- **Do not** turn on slopes unless necessary, and then, turn slowly and gradually downhill, if possible.
- **Do not** mow near drop-off, ditches, or embankments. The mower could suddenly turn over if a wheel is over the edge of a cliff or ditch, or if an edge caves in.
- **Do not** mow on wet grass. Reduced traction could cause sliding.
- **Do not** try to stabilize the machine by putting your foot on the ground.

Service

- Grass catcher components are subject to wear, damage, and deterioration, which could expose moving parts or allow objects to be thrown. Frequently check components and replace with manufacturer's recommended parts, when necessary.
- The operation of any mower can result in foreign objects thrown into the eyes, which can result in severe eye damage. Always wear safety glasses or eye shields while operating the mower or performing any adjustments or repairs. A wide vision safety mask over spectacles or standard safety glasses are recommended.
- Keep nuts and bolts, especially blade attachment bolts, tight and keep equipment in good condition.
- Never tamper with safety devices. Check regularly for proper operation.
- Keep machine free of grass, leaves, or other debris buildup.
- Clean oil or fuel spillage.
- Allow machine to cool before storing.
- Stop and inspect the equipment if you strike an object. Repair, if necessary, before restarting.
- Never make adjustments or repairs with the engine running.
- Mower blades are sharp and can cut. Wrap the blade(s) or wear gloves, and use extra caution when servicing them.
- Check brake operation frequently. Adjust and service as shown in the Operator Manual.

MAINTENANCE

Transport

 **CAUTION!** The collection system must be completely empty or removed while driving the mower forward onto a trailer. If the mower must be loaded onto a trailer while there is still debris in the container, the mower must be backed onto the trailer to avoid tipping.

 **CAUTION!** Do not transport the mower with the counterweights attached to the mounting bracket. Remove the counterweights after the mower is in the trailer. Secure the weights to the trailer separately.

- The machine is heavy and can cause serious crushing injuries. Be extra cautious when it is loaded on or unloaded from a vehicle or trailer.
- Use an approved trailer to transport the machine. Activate the parking brake, turn off the fuel supply, and fasten the machine with approved fastening devices, such as bands, chains or straps.
- Check and abide by local traffic regulations before transporting the machine on any road.
- Load the unit onto truck or trailer by driving up ramps of suitable strength using a slow speed. Do not lift! The machine is not intended to be lifted by hand.
- When loading or unloading this machine, do not exceed the maximum recommended operation angle of 10°.

Hose Care

1. Inspect hoses before each use. If hoses have excessive wear, tears or punctures, replace immediately.
2. To prolong the life of the hose, periodically rotate hose and turn hose end to end. Refer to Preventative Maintenance Schedule in this manual.
3. To decrease wear, avoid twists and sharp turns in the hoses.
4. Avoid dragging the lower hose along the sides of buildings or other hard surfaces.

Cleaning

Regular cleaning, washing, and lubricating will prolong the service of the machine.

NOTE: Use care with power washers to avoid damage to decals. DO NOT EXCEED 1000 PSI WATER PRESSURE FOR CLEANING

Storage

When grass catcher is to be stored for a period of time, clean it thoroughly, remove all dirt, grass, leaves, etc. Cover all scratches with touch-up paint.

Store in a clean, dry place. Covered or indoor storage is recommended.

Maintenance Schedule

ITEM	BEFORE EACH USE	EVERY 5 HOURS	EVERY 25 HOURS	EVERY 50 HOURS
Check/tighten nuts and bolts	X			
Check/tighten hoses	X			
Turn hose end to end			X	
Rotate hose				X
Clean machine				X

Troubleshooting Guide

Problem	Possible Cause
Loss of Vacuum	Hose or hood inlet clogged
	Container full
Unusual vibration or noise	Solid object jammed in unit
	Loose or missing bolts
Unit difficult to close	Obstructions keeping door from closing completely
	Hood hinge bolts are too tight

ASSEMBLY

1 INSTALLING REAR MOUNT AND STRAPS

1. Using a $\frac{9}{16}$ " wrench, remove the two bolts from the rear bumper.
2. Hook the collection system hitch over the rear bumper and secure the hitch to the bumper with two hex head flange screws and bolts.

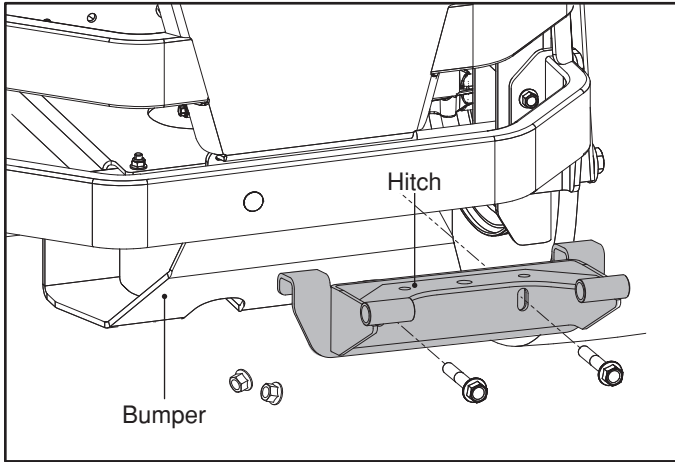

3. Install the mount pins through ROPS tube in predrilled holes approximately 18" up from bottom of ROPS tube. The pin will pass from the inside out, so the threads are on the outside of the tube. Secure each side with nuts and tighten using $\frac{3}{4}$ " and $\frac{9}{16}$ " wrenches.

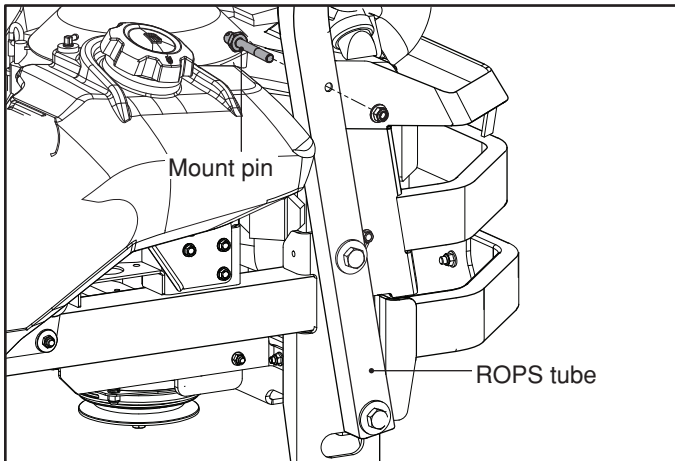

4. Attach the mounting straps to each side of the hopper front. Make sure the angled strap is attached to the side of the hopper near the handle. The straps are reversible and either end can be attached to the brackets.

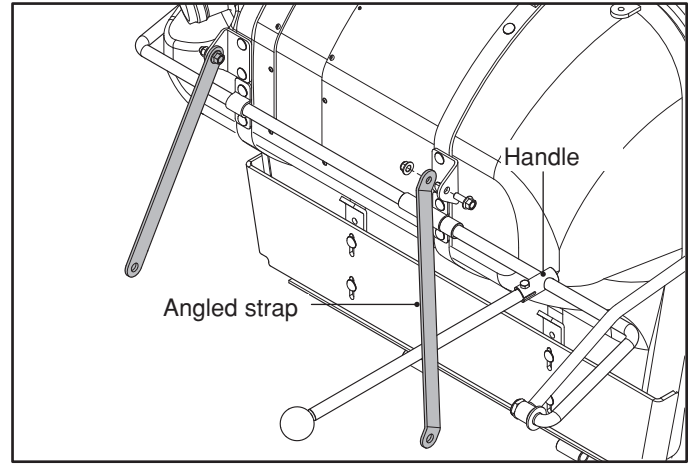

CAUTION! Make sure the clamshell is tightly closed and securely latched before engaging the mower blades.

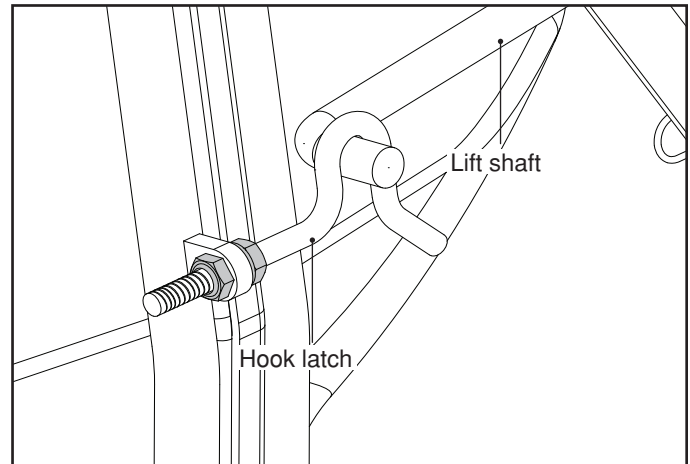

NOTE: It may be necessary to adjust the nuts on the clamshell hook latch to make sure it sits securely on the lift shaft.

ASSEMBLY

2 ATTACHING THE CLAMSHELL ASSEMBLY

1. Lift the clamshell assembly up to hitch that has been secured to the rear bumper. Align the pin tubes and slide the hinge pin through the hitch and clamshell assembly. Secure on the opposite side with the hairpin.

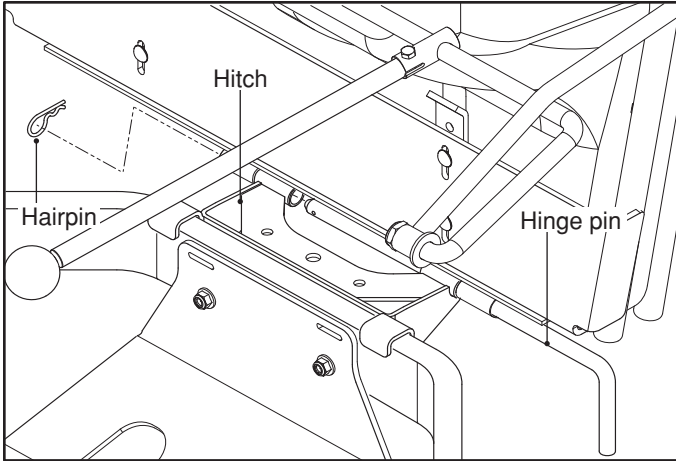

2. Rotate the mounting straps to align with the pins that have been installed on the ROPS tube. Attach the mounting straps to each pin and secure with a washer and hairpin.

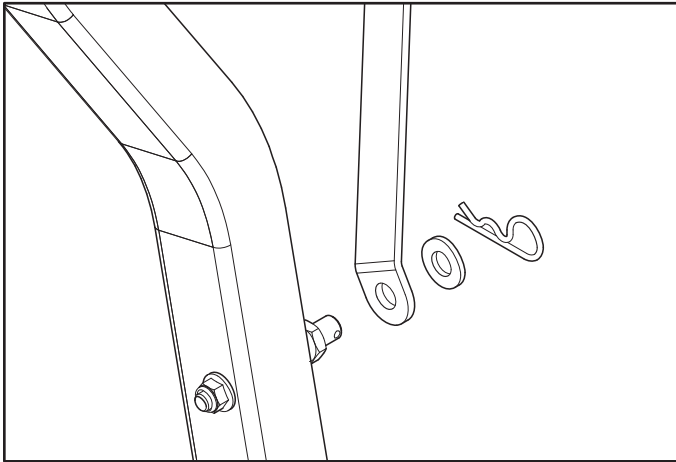

3 INSTALLING WEIGHT PLATES

1. Remove the foot rest by removing the four screws holding it to the frame.

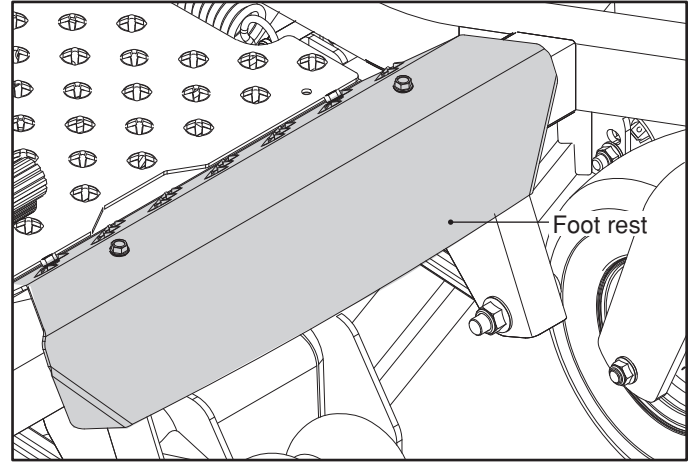

2. Attach three weight plates to the underside of the front frame using two U brackets and four 1/2" flanged nuts. **NOTE: On units with a 48" deck only - add the three plates from the drive kit, for a total of six plates.**
3. Reinstall the foot rest.

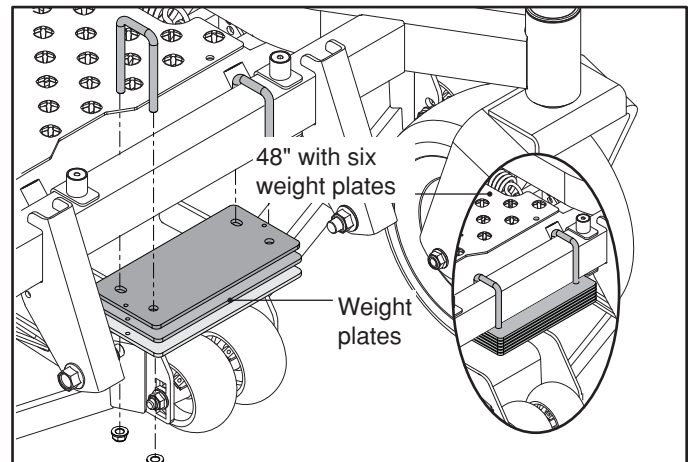

ASSEMBLY

4 INSTALLING CAST WEIGHTS

1. Set the mount bracket onto the frame tube just behind the caster pivot.
NOTE: Mount brackets can be placed on either the inboard or outboard side of the frame tube.
2. Press down on the bracket until it is securely snapped into place on the frame.
3. Push the cast weight into mount bracket, locking the release lever against the side of the frame tube.
4. Place the detent pin through the hole in the mount bracket to secure the weight.

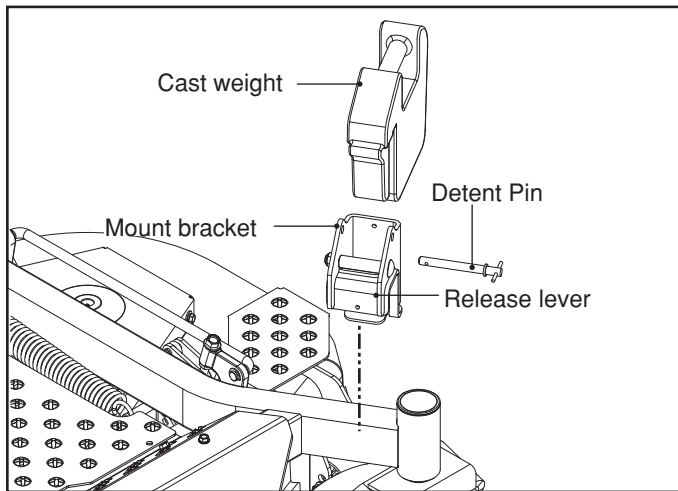

5 INSTALLING BLOW OUT BAFFLES

NOTE: The collection system includes optional deck baffling designed to help prevent blow out when collecting in extremely dry cutting conditions. If cutting conditions are not extremely dry, baffling may not be required.

1. Remove the hardware from deck's center baffle.
2. Place the left hand baffle from the kit between the deck skirt and the front edge of deck.
3. Secure the left hand baffle and the center baffle to the deck skirt with four 1" carriage bolts and nuts supplied with the kit, using a $\frac{7}{16}$ " wrench.
4. With a $\frac{1}{2}$ " wrench, install the right hand baffle on blade side of deck skirt and secure with two $\frac{1}{2}$ " carriage bolts and nuts from the kit.
5. Secure the blockout plate to the left hand side of the deck discharge opening with a $\frac{3}{4}$ " bolt and nut.

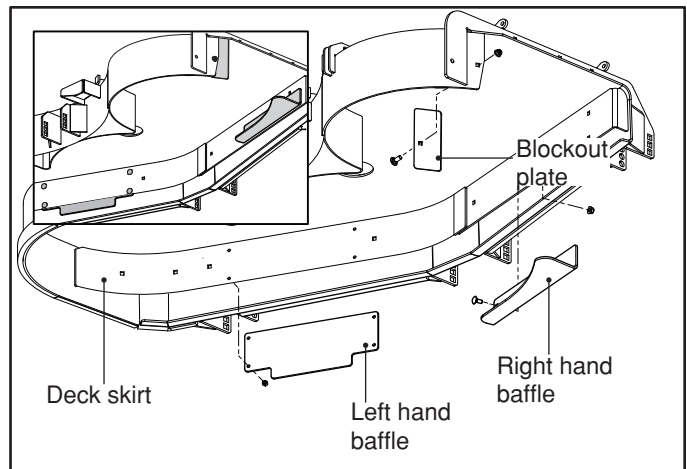

ASSEMBLY

6 INSTALLING DRIVE PULLEY - 48"

1. Using two $\frac{9}{16}$ " wrenches, remove the hardware and discharge chute from the deck.
2. Lower deck to the lowest cutting position.
3. With a $\frac{1}{2}$ " wrench, remove the hardware of the right hand (discharge side) belt cover and remove the shield from the deck.
4. Relieve the tension from the deck belt and remove it from the center deck pulley.
(See Operator Manual if necessary)

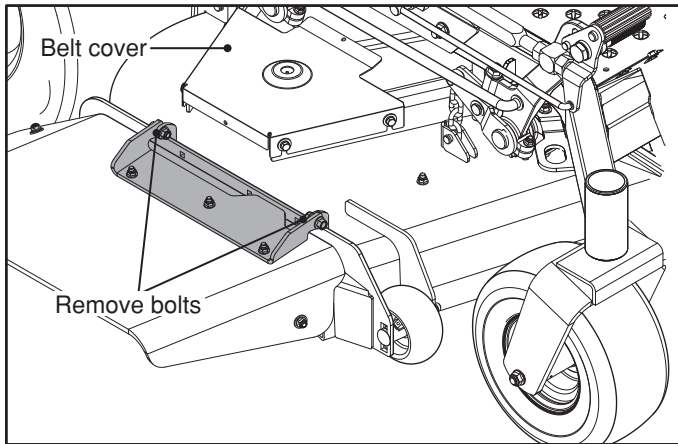

48" Deck

5. Remove the bolts and washers securing the right hand deck pulley to the spindle with a $\frac{1}{2}$ " wrench. Do not remove the pulley.
6. Install new drive pulley on top of the current deck pulley. Use a $\frac{1}{2}$ " wrench to secure the three $\frac{5}{8}$ " bolts and spring washers to the top of the pulley.
7. Reinstall the deck belt.

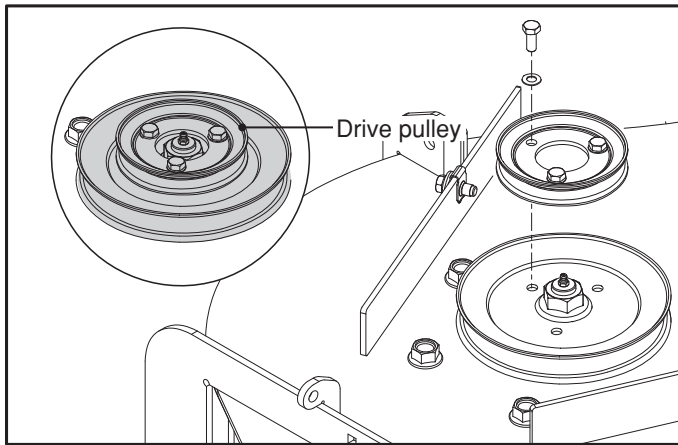

54" and 60" Deck

5. Remove the bolts and washers securing the right hand deck pulley to the spindle with a $\frac{1}{2}$ " wrench. Do not remove the pulley.
6. Install new drive pulley on top of the current deck pulley, placing spacers in between. Use a $\frac{1}{2}$ " wrench to secure the three $2\frac{1}{2}$ " bolts and spring washers to the top of the pulley. See illustration.
7. Reinstall the deck belt.

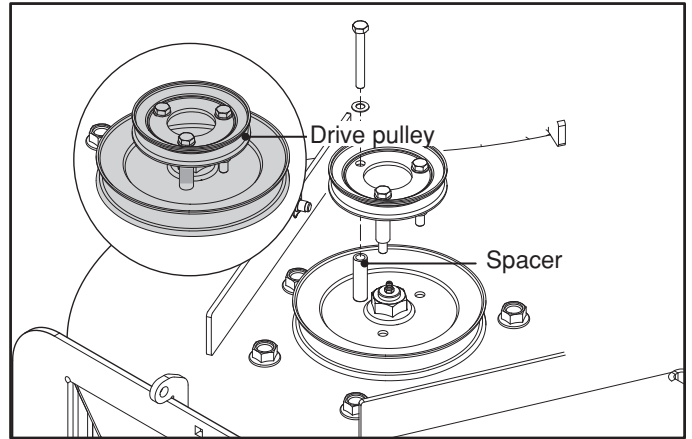

ASSEMBLY

7 MOUNTING BLOWER ASSEMBLY

1. Locate the lower rear latch assembly attached to the mounting bracket of the blower assembly. Pull the spring pin to release the assembly from the blower.

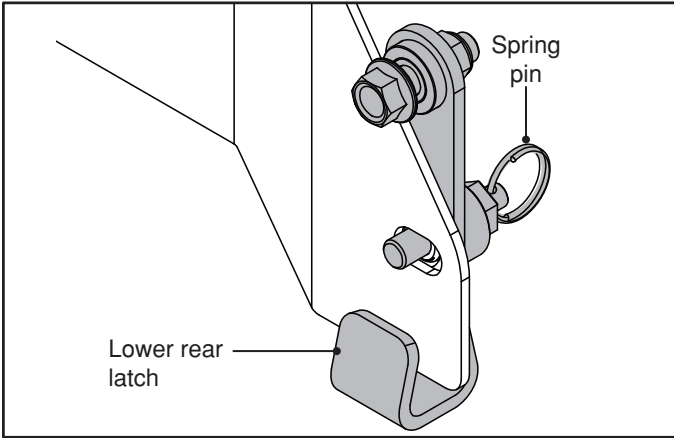

NOTE: Older model decks may need to have the top hole drilled into the deck.

3. Secure the latch to the deck with the spring pin and adjust latch vertically on the flange. Mark the location of the second hole and rotate the bracket out of the way. Drill a $\frac{7}{16}$ " hole at the mark.

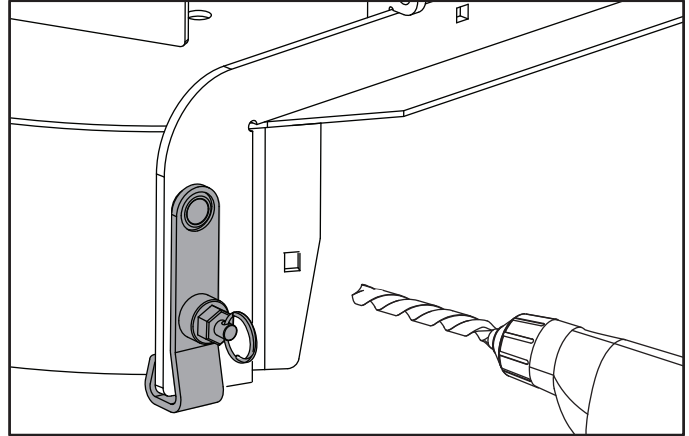

2. The assembly will be reattached to the deck discharge chute flange at the rear of the deck. Attach the latch to the outside of the deck flange using the top hole. Secure the spring pin the in the bottom hole

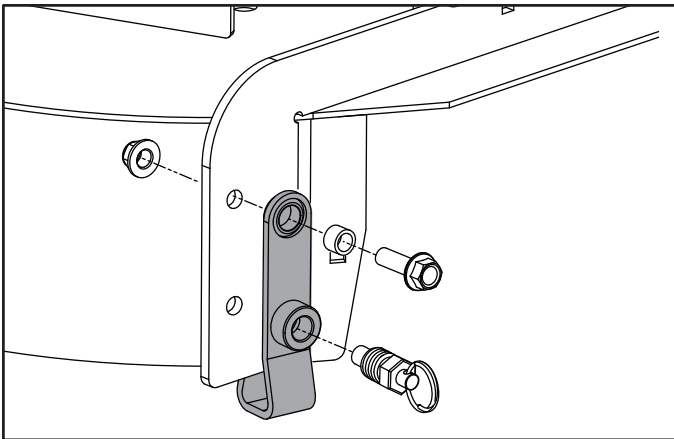

4. Move the latch assembly into place and attach the latch at the top hole with the bolt, spacer and nut.

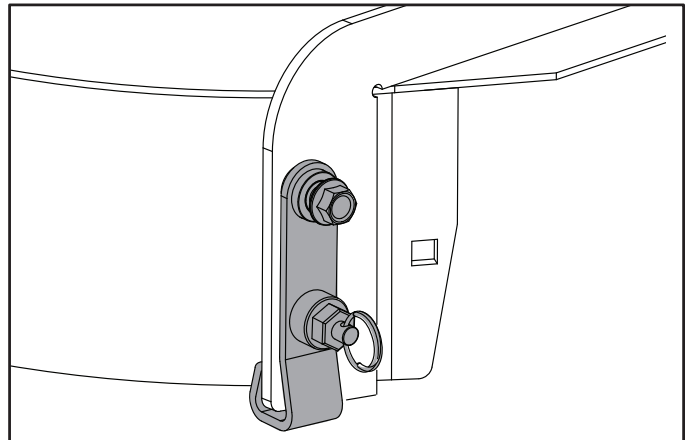

NOTE: The latch assembly can remain on the deck when the blower collection system is not used.

ASSEMBLY

- Slide the latch pins out and rotate up toward the upper housing.

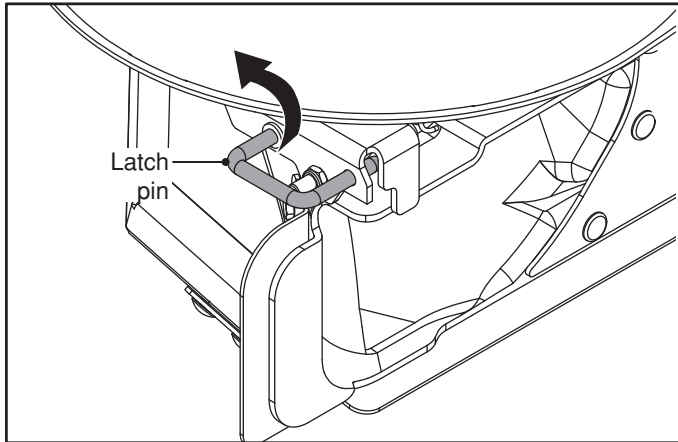

- Set the blower on the deck with the mount slots over the discharge chute mounting tabs.
- Rotate the latch pin back down, assuring it passes through the deck's front discharge chute mounting tab.
- Pull the spring pin and rotate the lower rear latch until the pin fits through the blower mounting bracket and deck flange.

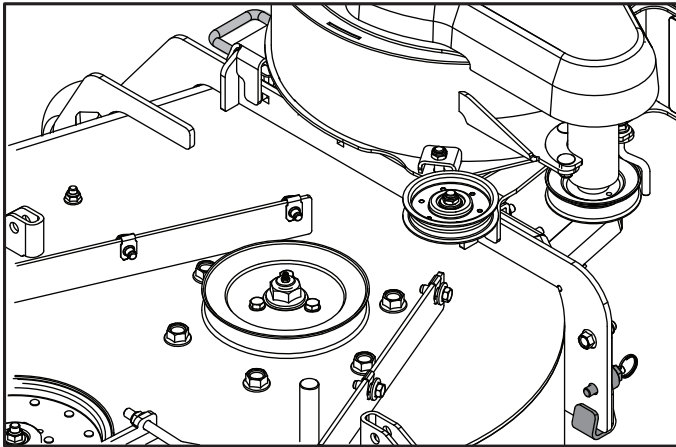

8 INSTALLING DRIVE BELT

- Install drive belt around pulley on blower.
- Rotate belt keeper within $\frac{1}{8}$ " of blower pulley and tighten with $\frac{1}{2}$ " wrench.
- Rotate blower idler towards front of blower and place belt over deck pulley. See illustration for correct belt routing.
NOTE: It may be necessary to disengage the latch pins and pivot the blower to aid in installing the drive belt. Reinstall the latch pins after the belt installation.

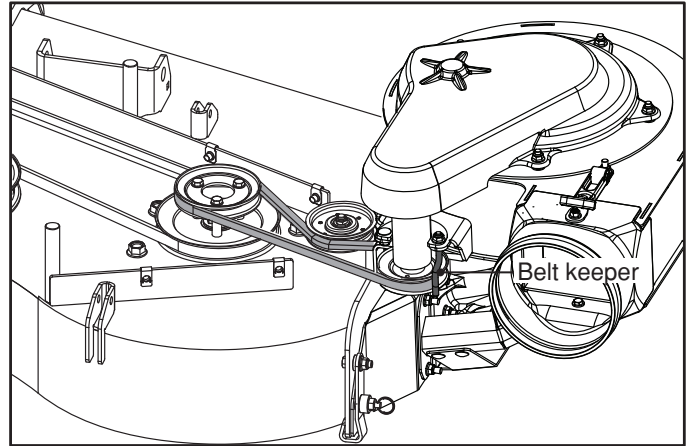

- Set drive kit deck belt cover over deck pulleys and reinstall deck shield hardware.

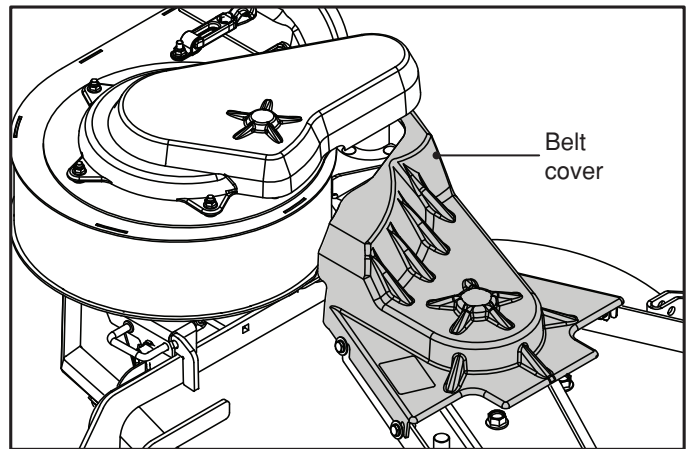

REPAIR PARTS

BLOWER

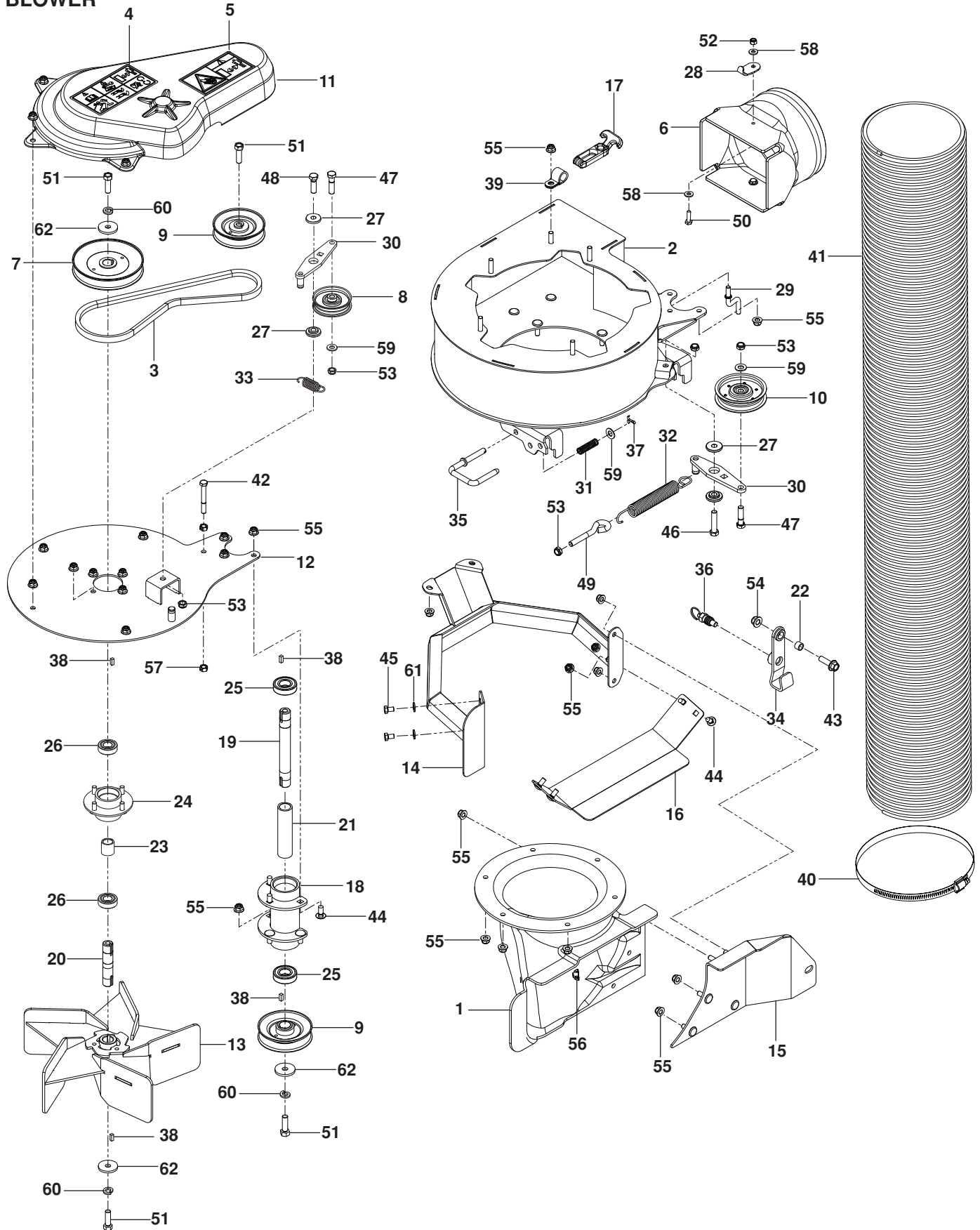

REPAIR PARTS

ITEM	PART NO.	QTY.	DESCRIPTION	ITEM	PART NO.	QTY.	DESCRIPTION
1..	522 59 33-01.....	1	HOUSING, BLOWER LOWER	32..	532 19 61-05.....	1	SPRING, DECK DRIVE
2..	585 85 60-02.....	1	HOUSING, BLOWER UPPER	33..	522 59 51-01.....	1	SPRING, IDLER
3..	539 10 13-86.....	1	BELT	34..	585 37 65-01.....	1	LATCH, RR LOWER
4..	539 10 57-85.....	1	DECAL, WARNING	35..	586 08 22-01.....	2	PIN, LATCH
5..	539 10 67-41.....	1	DECAL, IMPELLER	36..	585 37 68-01.....	1	PIN, SPRING
6..	585 23 68-02.....	1	CONNECTOR, HOSE	37..	876 02 04-12.....	2	PIN, COTTER 1/8 x 3/4
7..	539 13 03-24.....	1	PULLEY	38..	539 11 56-67.....	4	KEY 3/16 x 1/2
8..	539 10 67-21.....	1	PULLEY, IDLER	39..	539 10 26-85.....	2	CLAMP, TUBE
9..	522 59 46-01.....	2	PULLEY, DRIVE	40..	574 38 66-01.....	1	CLAMP, HOSE
10..	579 60 46-01.....	1	PULLEY, IDLER	41..	578 25 79-01.....	1	HOSE
11..	585 37 38-01.....	1	SHIELD, BELT TOP	42..	874 78 05-40.....	1	BOLT 5/16-18 x 2 1/2
12..	585 37 46-02.....	1	PLATE, TOP BLK	43..	525 83 42-01.....	1	BOLT 3/8-16 x 1 1/4 HEX FLANGE
13..	585 58 78-01.....	1	IMPELLER	44..	872 14 05-06.....	9	BOLT 5/16-18 x 3/4 RDHD SQNK
14..	585 37 57-02.....	1	GUARD, BLK	45..	874 78 05-08.....	2	BOLT 5/16-18 x 1/2
15..	585 37 62-02.....	1	BRACKET, BLOWER RR BLK	46..	539 97 69-49.....	1	BOLT 3/8-16 x 1 3/4
16..	585 37 64-02.....	1	SKID PLATE, BLK	47..	874 78 06-24.....	2	BOLT 3/8-16 x 1 1/2
17..	586 18 47-01.....	2	LATCH, DRAW T-HANDLE	48..	874 78 06-20.....	1	BOLT 3/8-16 x 1 1/4
18..	522 59 50-01.....	1	TUBE, SPINDLE	49..	539 10 74-84.....	1	EYEBOLT 3/8-16 x 2 1/4 SPEC
19..	585 37 54-01.....	1	SHAFT, SPINDLE	50..	539 99 06-43.....	2	SCREW 1/4-20 x 7/8 HEX CAP
20..	585 37 56-01.....	1	SHAFT, IMPELLER	51..	532 85 08-57.....	4	SCREW 3/8-24 x 1 1/4 HEX HD
21..	585 37 55-01.....	1	SPACER	52..	539 97 69-78.....	2	NUT 1/4-20 HEX NYLOC
22..	579 61 33-01.....	1	SPACER	53..	539 20 02-82.....	5	NUT 3/8-16 HEX NYLON THIN
23..	585 37 53-01.....	1	SPACER	54..	521 99 65-01.....	1	NUT 3/8-16 HEX FLG NYLOC
24..	585 37 49-01.....	1	HOUSING, HUB	55..	539 11 28-99.....	37	NUT 5/16-18 HEX FLG NYLOC
25..	539 13 02-96.....	2	BEARING	56..	539 13 03-13.....	2	NUT 5/16-18 TEE
26..	585 37 52-01.....	2	BEARING	57..	539 99 01-84.....	2	NUT 5/16-18 HEX CTRLK
27..	539 13 21-61.....	4	BUSHING, BRAKE	58..	819 09 10-16.....	4	WASHER
28..	586 08 23-01.....	2	KEEPER, LATCH	59..	819 13 13-16.....	3	WASHER FLAT
29..	522 59 52-01.....	1	KEEPER, BELT	60..	810 03 06-00.....	4	WASHER LOCK HVY 3/8
30..	522 59 48-02.....	2	IDLER, BLK	61..	819 11 11-16.....	2	WASHER 16 GA
31..	525 81 60-01.....	1	SPRING, COMPRESSION	62..	532 14 02-96.....	4	WASHER, BLADE

NOTE: ALL FASTENERS ARE GRADE 5 UNLESS OTHERWISE SPECIFIED.

REPAIR PARTS

CLAMSHELL REAR

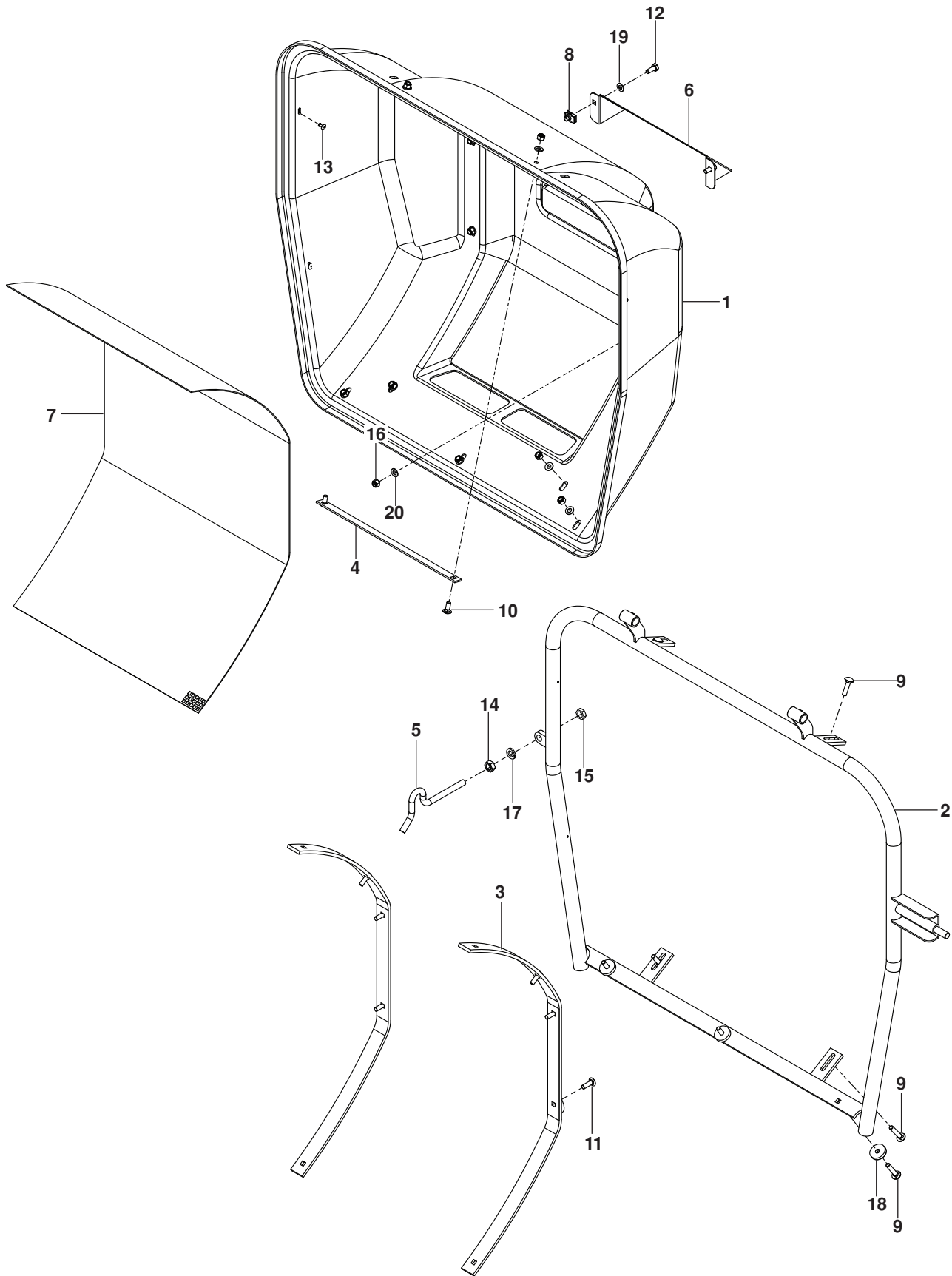

REPAIR PARTS

ITEM	PART NO.	QTY.	DESCRIPTION	ITEM	PART NO.	QTY.	DESCRIPTION
1..	539 11 93-77.....	1	CLAMSHELL BACK	11..	539 10 72-71.....	6	BOLT ⁵ / ₁₆ 18 x 1 RDHD SQNK
2..	539 11 79-87.....	1	FRAME, REAR	12..	539 99 02-06.....	2	BOLT ⁵ / ₁₆ -18 x ³ / ₄
3..	539 11 93-96.....	2	STRAP	13..	539 11 94-13.....	6	RIVET
4..	539 11 94-58.....	1	STRAP	14..	539 11 56-09.....	1	NUT ¹ / ₂ -13 THIN NYLOC
5..	539 11 93-67.....	1	HOOK LATCH	15..	539 99 06-25.....	1	NUT ¹ / ₂ -13 HEX JAM
6..	539 11 75-43.....	1	VENT, CLAMSHELL	16..	539 99 07-17.....	15	NUT ⁵ / ₁₆ -18 NYLOC
7..	581 53 29-01.....	1	SCREEN, VENT	17..	539 99 02-54.....	1	WASHER ¹ / ₂ LOCK
8..	539 11 56-77.....	2	RETAINER, U TYPE	18..	539 11 57-89.....	3	WASHER, NYLON
9..	539 10 04-72.....	7	BOLT ⁵ / ₁₆ -18 x 1 ¹ / ₄ RDHD SQNK	19..	539 99 01-88.....	2	WASHER ⁵ / ₁₆ SAE
10..	539 99 03-16.....	2	BOLT ⁵ / ₁₆ -18 x ³ / ₄ RDHD SQNK	20..	539 99 06-92.....	15	WASHER ⁵ / ₁₆ STD

NOTE: ALL FASTENERS ARE GRADE 5 UNLESS OTHERWISE SPECIFIED.

REPAIR PARTS

CLAMSHELL FRONT

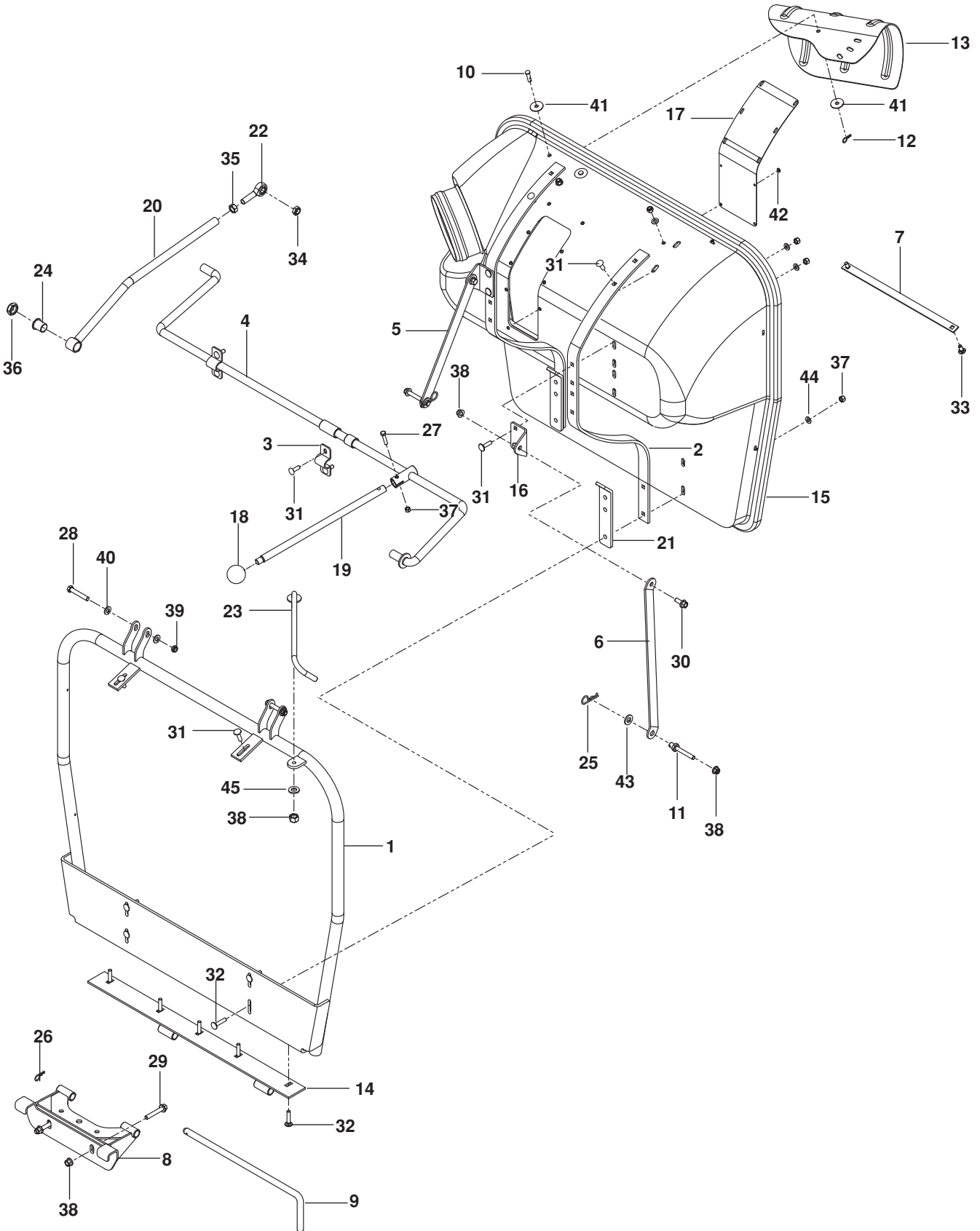

REPAIR PARTS

ITEM	PART NO.	QTY.	DESCRIPTION	ITEM	PART NO.	QTY.	DESCRIPTION
1..	539 11 94-10.....	1	FRONT FRAME	24..	539 11 59-72.....	2	BUSHING
2..	539 11 94-09.....	2	STRAP	25..	539 97 69-89.....	2	HAIRPIN 2½
3..	539 11 93-68.....	2	STRAP	26..	539 11 55-01.....	1	HAIRPIN 1¾
4..	580 98 00-01.....	1	SHAFT, LIFT	27..	539 97 69-35.....	1	BOLT 5/16-18 x 1½
5..	580 97 95-02.....	1	STRAP, MOUNTING, LT BLK	28..	539 99 06-29.....	2	BOLT 3/8-18 x 2¼
6..	580 97 96-02.....	1	STRAP, MOUNTING, RT BLK	29..	577 09 83-01.....	2	BOLT 3/8-16 x 2¼ HEX FLG GR8
7..	539 11 94-58.....	1	STRAP	30..	525 61 28-01.....	2	BOLT 3/8-16 x 1 HEX FLG HD
8..	580 97 91-02.....	1	HITCH, BLK	31..	539 10 04-72.....	12	BOLT 5/16-18 x 1¼ RDHD SQNK
9..	539 11 93-72.....	1	PIN, HINGE	32..	539 10 29-33.....	9	BOLT 5/16-18 x 1½ RDHD SQNK
10..	539 11 55-96.....	2	PIN 5/16 CLEVIS	33..	539 99 03-16.....	2	BOLT 5/16-18 x ¾ RDHD SQNK
11..	525 44 50-01.....	2	PIN, MOUNT	34..	539 10 80-10.....	1	NUT ½-13 THIN NYLOC
12..	532 00 49-39.....	2	PIN, RETAINER	35..	539 10 87-63.....	1	NUT ½-20 JAM
13..	539 11 94-33.....	1	DEFLECTOR	36..	522 84 26-01.....	1	NUT ¾-16 THIN NYLOC
14..	539 11 47-79.....	1	MOUNT, LOWER	37..	539 99 07-17.....	23	NUT 5/16-18 NYLOC
15..	580 97 83-01.....	1	CLAMSHELL, FRONT	38..	521 99 65-01.....	6	NUT 3/8-16 HEX FLG NYLOC
16..	580 97 97-02.....	2	BRACKET, MOUNTING	39..	539 20 02-82.....	2	NUT 3/8-16 HEX JAM NYLOC
17..	539 11 54-41.....	1	WINDOW	40..	539 99 01-22.....	4	WASHER 3/8 SAE FLT
18..	580 98 06-01.....	1	KNOB, BLK	41..	539 11 54-95.....	4	WASHER 11/32
19..	580 98 05-01.....	1	ARM, DUMP	42..	539 11 00-33.....	10	WASHER
20..	539 11 48-16.....	1	ARM, LIFT	43..	539 99 02-50.....	2	WASHER, SAE
21..	539 11 79-88.....	2	PLATE, SPACER	44..	539 99 06-92.....	23	WASHER 5/16 STD
22..	539 11 72-44.....	1	ROD END	45..	539 99 01-88.....	1	WASHER 5/16 SAE
23..	539 11 48-16.....	1	LINKAGE, LATCH				

NOTE: ALL FASTENERS ARE GRADE 5 UNLESS OTHERWISE SPECIFIED.

REPAIR PARTS

WEIGHTS, BAFFLES, SHIELDS

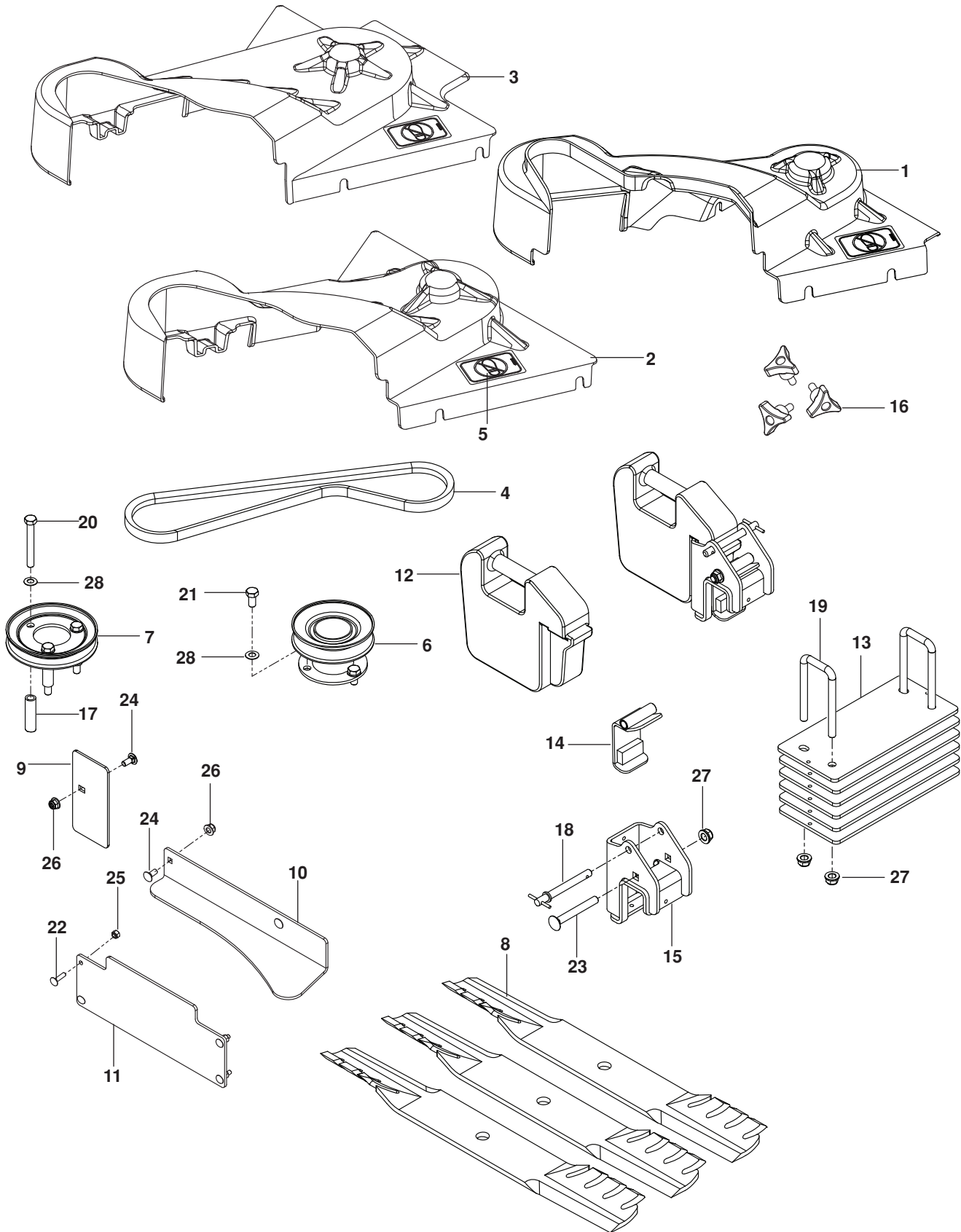

REPAIR PARTS

ITEM	PART NO.	QTY.	DESCRIPTION	ITEM	PART NO.	QTY.	DESCRIPTION
1..	581 17 65-01.....	1SHIELD, BELT, 48"	15..	575 50 98-02.....	2BRACKET, WEIGHT, BLK
2..	522 59 58-02.....	1SHIELD, BELT, 54"	16..	539 10 44-11.....	3KNOB w/STUD
3..	522 59 58-01.....	1SHIELD, BELT, 60"	17..	573 98 27-01.....	3SPACER
4..	574 21 60-01.....	1BELT, BLOWER 48"	18..	575 50 99-01.....	2PIN, DETENT
	539 10 04-39.....	1BELT, BLOWER 54"	19..	575 88 06-01.....	2BOLT, U
	574 21 61-01.....	1BELT, BLOWER 60"	20..	539 10 83-92.....	3BOLT ⁵ / ₁₆ -18 x 2 ¹ / ₂
5..	539 10 57-43.....	1DECAL, NO STEP	21..	539 10 83-92.....	3BOLT ⁵ / ₁₆ -18 x ⁵ / ₈
6..	522 59 45-03.....	1PULLEY, DRIVE 48"	22..	539 10 98-00.....	4BOLT ¹ / ₄ -20 x 1 RDHD SQNK
7..	522 59 45-02.....	1PULLEY, DRIVE 54"	23..	539 10 84-84.....	2BOLT ¹ / ₂ -13 x 4 RDHD SQNK
	522 59 45-01.....	1PULLEY, DRIVE 60"	24..	539 99 03-16.....	3BOLT ⁵ / ₁₆ -18 x ³ / ₄ RDHD SQNK
8..	525 52 59-01.....	3BLADE, GATOR 54"	25..	539 97 69-78.....	4NUT ¹ / ₄ -20 HEX NYLOC
	522 93 66-01.....	3BLADE, GATOR 60"	26..	539 11 28-99.....	3NUT ⁵ / ₁₆ -18 HEX FLG NYLOC
9..	525 79 87-01.....	1PLATE, BLOCK OFF	27..	521 99 11-01.....	6NUT ¹ / ₂ -13 HEX FLG NYLOC
10..	575 59 41-02.....	1BAFFLE, RT	28..	539 10 96-00.....	3WASHER ⁵ / ₁₆ DISC SPRING
11..	575 59 36-02.....	1BAFFLE, LT				
12..	539 09 25-31.....	2WEIGHT CAST, FRONT				
13..	575 88 05-01.....	6WEIGHT PLATE				
14..	575 50 95-01.....	2LATCH				

NOTE: ALL FASTENERS ARE GRADE 5 UNLESS OTHERWISE SPECIFIED.

