

INSTALLATION AND REPAIR PARTS MANUAL

97 CM REPLACEMENT MOWER DECK
FOR LAWN TRACTORS

PART NUMBER **596 55 13-01**

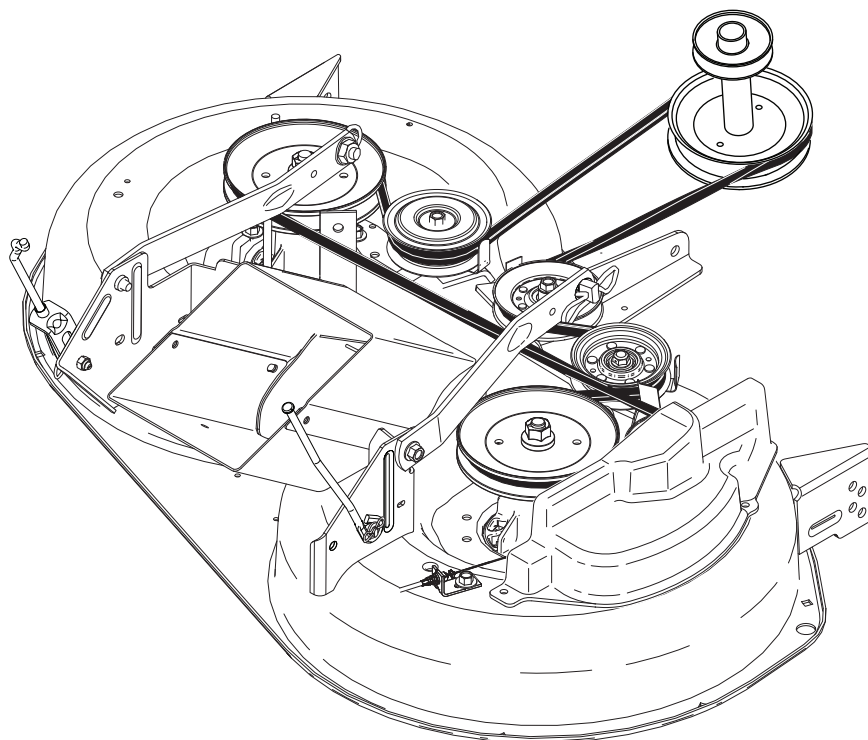



SAFETY RULES

Safe Operation Practices for Ride-On Mowers



DANGER: THIS CUTTING MACHINE IS CAPABLE OF AMPUTATING HANDS AND FEET AND THROWING OBJECTS. FAILURE TO OBSERVE THE FOLLOWING SAFETY INSTRUCTIONS COULD RESULT IN SERIOUS INJURY OR DEATH.



WARNING: In order to prevent accidental starting when setting up, transporting, adjusting or making repairs, always disconnect spark plug wire and place wire where it cannot contact spark plug.



WARNING: Do not coast down a hill in neutral, you may lose control of the tractor.



WARNING: Tow only the attachments that are recommended by and comply with specifications of the manufacturer of your tractor. Use common sense when towing. Operate only at the lowest possible speed when on a slope. Too heavy of a load, while on a slope, is dangerous. Tires can lose traction with the ground and cause you to lose control of your tractor.



WARNING

Engine exhaust, some of its constituents, and certain vehicle components contain or emit chemicals known to the State of California to cause cancer and birth defects or other reproductive harm.



WARNING

Battery posts, terminals and related accessories contain lead and lead compounds, chemicals known to the State of California to cause cancer and birth defects or other reproductive harm. Wash hands after handling.

I. CHILDREN



WARNING! CHILDREN CAN BE INJURED BY THIS EQUIPMENT. The American Academy of Pediatrics recommends that children be a minimum of 12 year of age before operating a pedestrian controlled lawn mower and a minimum of 16 years of age before operating a riding lawn mower.



WARNING! CHILDREN CAN BE SERIOUSLY INJURED OR KILLED BY THIS EQUIPMENT. Carefully read and follow all of the safety instructions below.

Tragic accidents can occur if the operator is not alert to the presence of children. Children are often attracted to the machine and the mowing activity. Never assume that children will remain where you last saw them.

- Keep children out of the mowing area and in the watchful care of a responsible adult **other than** the operator.

- Be alert and turn machine off if a child enters the area.
- Before and while backing, look behind and down for small children.
- Never carry children, even with the blades shut off. They may fall off and be seriously injured or interfere with safe machine operation. Children who have been given rides in the past may suddenly appear in the mowing area for another ride and be run over or backed over by the machine.
- Never allow children to operate the machine.
- Use extreme caution when approaching blind corners, shrubs, trees, or other objects that may block your view of a child.

II. GENERAL OPERATION

- Read, understand, and follow all instructions on the machine and in the manual before starting.
- Do not put hands or feet near rotating parts or under the machine. Keep clear of the discharge opening at all times.
- Only allow responsible adults, who are familiar with the instructions, to operate the machine.
- Clear the area of objects such as rocks, toys, wire, etc., which could be picked up and thrown by the blades.
- Ensure the area is clear of bystanders before operating. Stop machine if anyone enters the area.
- Never carry passengers.
- Do not mow in reverse unless absolutely necessary. Always look down and behind before and while backing.
- Never direct discharged material toward anyone. Avoid discharging material against a wall or obstruction. Material may ricochet back toward the operator. Stop the blades when crossing gravel surfaces.
- Do not operate machine without the entire grass catcher, discharge chute, or other safety devices in place and working.
- Slow down before turning.
- Never leave a running machine unattended. Always turn off blades, set parking brake, stop engine, and remove keys before dismounting.
- Disengage blades when not mowing. Shut off engine and wait for all parts to come to a complete stop before cleaning the machine, removing the grass catcher, or unclogging the discharge chute.
- Operate machine only in daylight or good artificial light.
- Do not operate the machine while under the influence of alcohol or drugs.
- Watch for traffic when operating near or crossing roadways.
- Use extreme caution when loading or unloading the machine into a trailer or truck.
- Always wear eye protection when operating machine.
- Use ear protectors to avoid damage to hearing.
- Data indicates that operators, age 60 years and above, are involved in a large percentage of riding mower-related injuries. These operators should evaluate their ability to operate the riding mower safely enough to protect themselves and others from serious injury.
- Follow the manufacturer's recommendation for wheel weights or counterweights.
- Keep machine free of grass, leaves or other debris build-up which can touch hot exhaust / engine parts and burn. Do not allow the mower deck to plow leaves or other debris which can cause build-up to occur. Clean any oil or fuel spillage before operating or storing the machine. Allow machine to cool before storage.



SAFETY RULES

Safe Operation Practices for Ride-On Mowers



III. SLOPE OPERATION



WARNING! When loading or unloading this machine, do not exceed the maximum recommended operation angle of 15°.

Slopes are a major factor related to loss of control and tip-over accidents, which can result in severe injury or death. Operation on all slopes requires extreme caution. If you cannot back up the slope or if you feel uneasy on it, do not mow it.

- Mow up and down slopes, not across.
- Watch for holes, ruts, bumps, rocks, or other hidden objects. Uneven terrain could overturn the machine. Tall grass can hide obstacles.
- Choose a low ground speed so that you will not have to stop or shift while on the slope.
- Do not mow on wet grass. Tires may lose traction. Always keep the machine in gear when going down slopes.
- Do not shift to neutral and coast downhill.
- Avoid starting, stopping, or turning on a slope. If the tires lose traction, disengage the blades and proceed slowly straight down the slope.
- Keep all movement on the slopes slow and gradual. Do not make sudden changes in speed or direction, which could cause the machine to roll over.
- Use extreme caution while operating machine with grass catchers or other attachments; they can affect the stability of the machine. Do not use on steep slopes.
- Do not try to stabilize the machine by putting your foot on the ground.
- Do not mow near drop-offs, ditches, or embankments. The machine could suddenly roll over if a wheel is over the edge or if the edge caves in.
- If machine stops while going uphill, disengage blades, shift into reverse and back down slowly.
- Do not turn on slopes unless necessary, and then, turn slowly and gradually downhill, if possible.



IV. TOWING

- Tow only with a machine that has a hitch designed for towing. Do not attach towed equipment except at the hitch point.
- Follow the manufacturer's recommendation for weight limits for towed equipment and towing on slopes.
- Never allow children or others in or on towed equipment.
- On slopes, the weight of the towed equipment may cause loss of traction and loss of control.
- Travel slowly and allow extra distance to stop.

V. SERVICE

SAFE HANDLING OF GASOLINE

To avoid personal injury or property damage, use extreme care in handling gasoline. Gasoline is extremely flammable and the vapors are explosive.

- Extinguish all cigarettes, cigars, pipes, and other sources of ignition.
- Use only approved gasoline container.

- Never remove gas cap or add fuel with the engine running.
- Allow engine to cool before refueling.
- Never fuel the machine indoors.
- Never store the machine or fuel container where there is an open flame, spark, or pilot light such as on a water heater or other appliances.
- Never fill containers inside a vehicle or on a truck or trailer bed with plastic liner. Always place containers on the ground away from your vehicle when filling.
- Remove gas-powered equipment from the truck or trailer and refuel it on the ground. If this is not possible, then refuel such equipment with a portable container, rather than from a gasoline dispenser nozzle.
- Keep the nozzle in contact with the rim of the fuel tank or container opening at all times until fueling is complete. Do not use a nozzle lock-open device.
- If fuel is spilled on clothing, change clothing immediately.
- Never overfill fuel tank. Replace gas cap and tighten securely.

GENERAL SERVICE

- Never operate machine in a closed area.
- Keep all nuts and bolts tight to ensure the equipment is in safe working condition.
- Never tamper with safety devices. Never interfere with the intended function of a safety device or reduce the protection provided by a safety device. Check their proper operation regularly. NEVER operate a machine with a safety device that does not function properly.
- Keep machine free of grass, leaves, or other debris build-up. Clean oil or fuel spillage and remove any fuel-soaked debris. Allow machine to cool before storing.
- If you strike a foreign object, stop and inspect the machine. Repair, if necessary, before restarting.
- Never make any adjustments or repairs with the engine running.
- Check grass catcher components and the discharge chute frequently and replace with manufacturer's recommended parts, when necessary.
- Mower blades are sharp. Wrap the blade or wear gloves, and use extreme caution when servicing them.
- Check brake operation frequently. Adjust and service as required.
- Maintain or replace safety and instruction labels, as necessary.



Use ear protectors to avoid damage to hearing.



Always wear eye protection when operating machine.

REMOVAL & INSTALLATION



WARNING: TO AVOID SERIOUS INJURY, BEFORE PERFORMING ANY SERVICE OR ADJUSTMENTS:

- Depress brake pedal fully and set parking brake.
- Place attachment clutch in “DISENGAGED” position.
- Turn ignition key to “STOP” and remove key.
- Make sure the blades and all moving parts have completely stopped.
- Disconnect spark plug wire from spark plug and place wire where it cannot come in contact with plug.

TO REMOVE CENTER CHUTE (See Fig. 1)

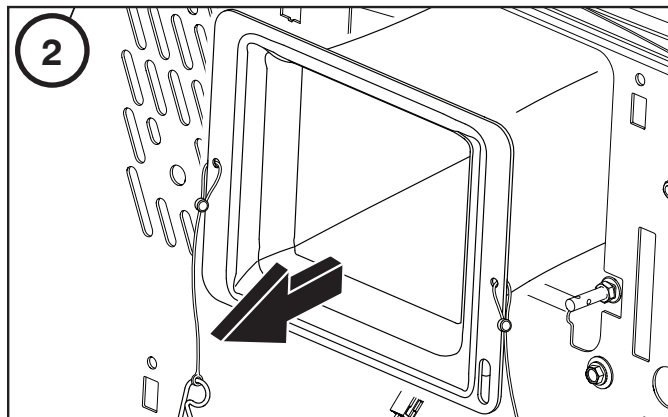
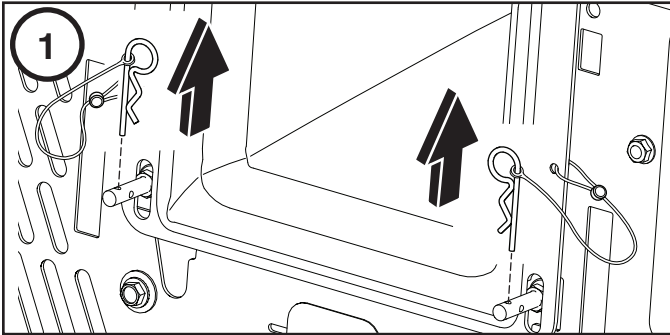

Fig. 1

TO REMOVE MOWER (See Fig. 2)

Mower will be easier to remove from the right side of tractor.

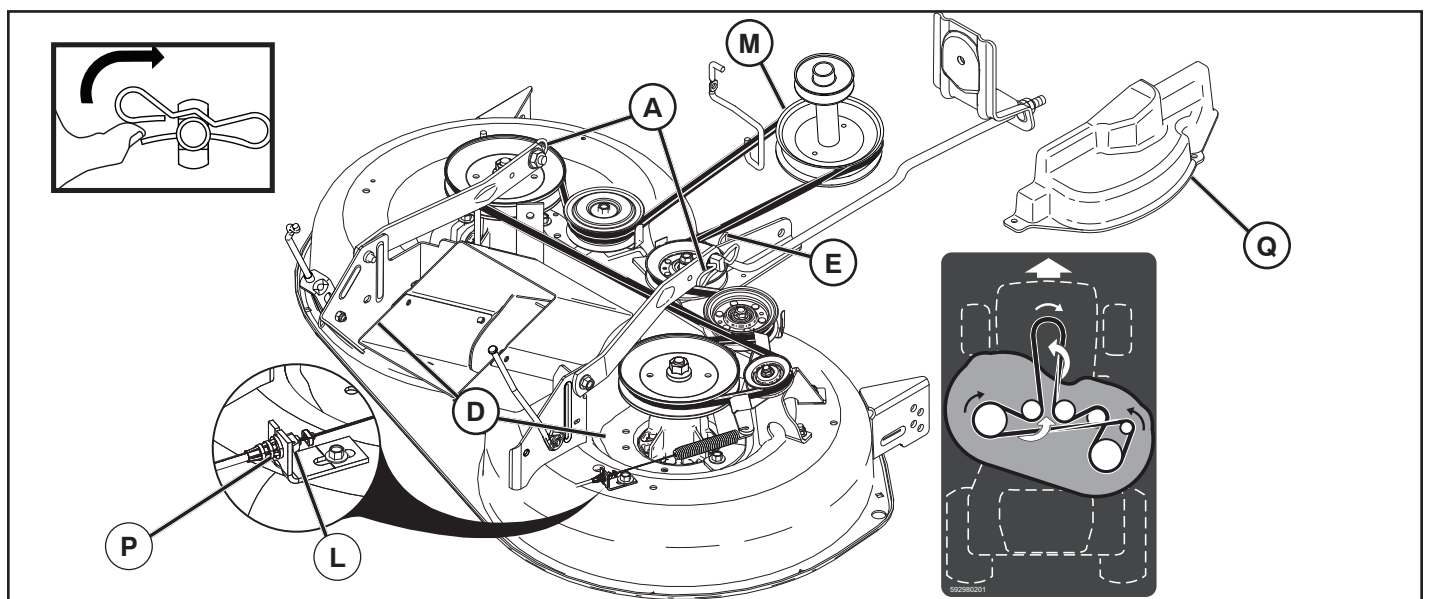

Fig. 2

- Remove center chute as described previously.
- Place attachment clutch in “DISENGAGED” position.
- Lower attachment lift lever to its lowest position.
- Remove mandrel cover (Q)
- Remove cable (P) by depressing tab (L)
- Remove mower belt from clutch pulley (M).
- Dismantle the retainer spring (E) and remove the lever.
- Dismantle the retainer spring (A) and remove the lever.
- Dismantle the retainer spring (D) and remove the lever.

IMPORTANT: IF AN ATTACHMENT OTHER THAN THE MOWER DECK IS TO BE MOUNTED ON THE TRACTOR, REMOVE THE FRONT LINKS.

- Slide mower out from under right side of tractor.



CAUTION: Attachment lift lever is spring loaded. Have a tight grip on rod and release slowly.

TO INSTALL MOWER

- Push in the mower deck under the tractor.
- Assemble in the reverse order to dismantling.

IMPORTANT: Check belt for proper routing in all mower pulley grooves.

NOTE: Arrows on belt routing image represent a twist in the belt in order to correctly align with pulleys, narrow side of belt always mate to pulleys, wide side of belt always mate to flat idlers.

- Raise attachment lift lever to highest position.

REMOVAL & INSTALLATION

TO LEVEL MOWER

Ensure tires are properly inflated to the PSI shown on tires. If tires are over or under inflated, it may affect the appearance of your lawn and lead you to think the mower is not adjusted properly.

VISUAL SIDE-TO-SIDE ADJUSTMENT (See Fig. 3)

- With all tires properly inflated and if your lawn appears unevenly cut, determine which side of mower is cutting lower.
- With a 3/4" or adjustable wrench, turn lift link adjustment nut (A) to the left to lower LH side of mower, or, to the right to raise LH side of mower.

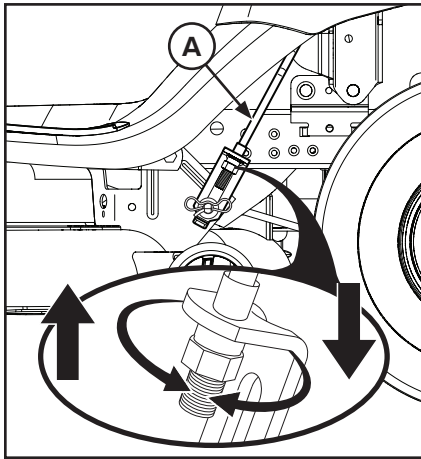

Fig. 3

NOTE: Each full turn of adjustment nut will change mower height about 3/16" (4,7 mm).

- Test your adjustment by mowing some uncut grass and visually checking the appearance. Readjust, if necessary, until you are satisfied with the results.

PRECISION SIDE-TO-SIDE ADJUSTMENT (See Fig. 4)

- With all tires properly inflated, park tractor on level ground or driveway.



CAUTION: Blade is sharp. Protect your hands with gloves and/or wrap blade with heavy cloth.

- Raise mower to its highest position.
- At both sides of mower, position blade at side and measure the distance (A) from bottom edge of blade to the ground. The distance should be the same on both sides.

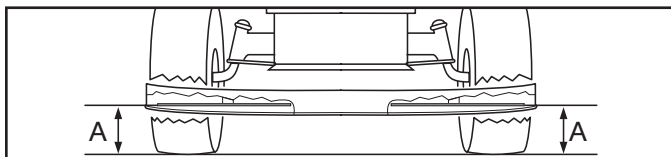

Fig. 4

- If adjustment is necessary, see steps in Visual Adjustment instructions above.
- Recheck measurements, adjust if necessary until both sides are equal.

FRONT-TO-BACK ADJUSTMENT (See Figs. 5 & 6)

IMPORTANT: Deck must be level side-to-side.

To obtain the best cutting results, the mower blades should be adjusted so the front tip is 1/8" to 3/8" (3,1 to 9,5 mm) lower than the rear tip when the mower is in its highest position.



CAUTION: Blade is sharp. Protect your hands with gloves and/or wrap blade with heavy cloth.

- Raise mower to highest position.
- Position blade so the tip is pointing straight forward. Measure distance (B) to the ground at front and rear tip of the blade.

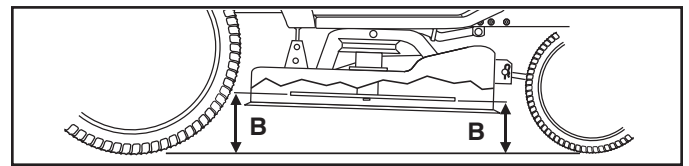

Fig. 5

- If front tip of blade is not 1/8" to 3/8" (3,1 to 9,5 mm) lower than the rear tip, go to the front of tractor.
- With an 11/16" or adjustable wrench, loosen jam nut A several turns to clear adjustment nut B.
- With a 3/4" or adjustable wrench, turn front link adjustment nut (B) clockwise (↻) (tighten) to raise the front of mower, or, counterclockwise (↺) (loosen) to lower the front mower.

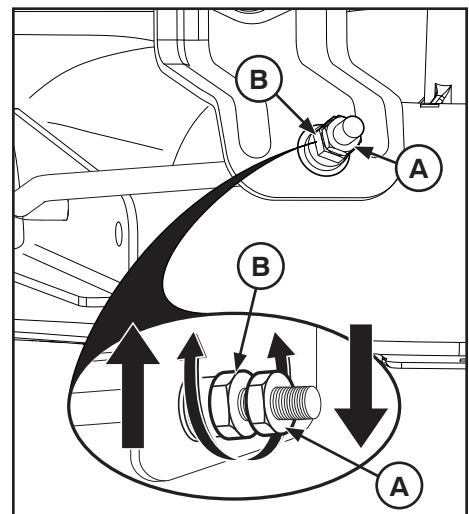

Fig. 6

NOTE: Each full turn of the adjustment nut will change mower height about 1/8" (3,1 mm).

- Recheck measurements, adjust if necessary until front tip of blade is 1/8" to 3/8" (3,1 to 9,5 mm) lower than the rear tip.
- Hold adjustment nut in position with wrench and tighten jam nut securely against adjustment nut.

REPAIR PARTS

38" (97 CM) REPLACEMENT MOWER DECK PART # 596 55 13-01

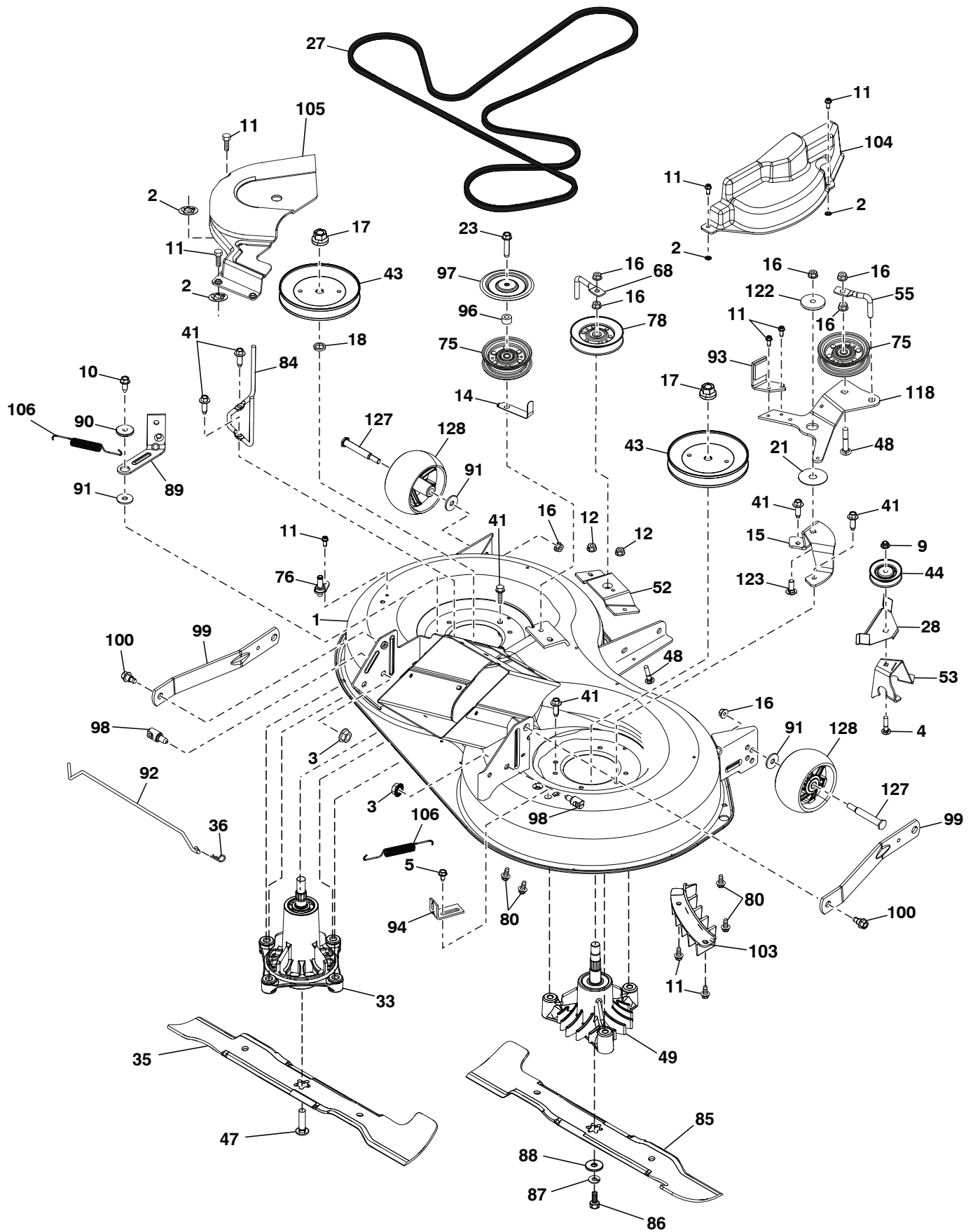

REPAIR PARTS

38" (97 CM) REPLACEMENT MOWER DECK PART # 596 55 13-01

KEY NO.	PART NO.	DESCRIPTION	KEY NO.	PART NO.	DESCRIPTION
1	592 85 42-02	97 CRD Shell Weldment	76	532 43 96-40	Washout Port
2	532 42 30-62	Palnut 1/4	78	532 17 39-02	Pulley Idler V-GR. Plated 4.25
3	596 13 57-01	Nut, Lock, Prvl. Torq. 5/16-18 x .68	80	595 90 16-01	Bolt, Cup 5/16 x 3/4 Clr. Zn
4	872 11 05-10	Bolt Carr. 5/16-18 x 1-1/4 Gr. 5	84	589 67 61-02	Keeper, Belt, Mandrel
5	817 00 05-10	Bolt 5/16-18	85	532 42 79-85	Blade
9	585 69 13-01	Nut Hex Flg Nylock	86	532 18 17-13	Bolt 3/8-24 x 1.50
10	817 00 06-16	Screw 3/8-16 x 1	87	596 23 87-01	Washer, Spring, Lock
11	532 13 77-29	Screw 1/4-20 x 5/8	88	532 14 02-96	Washer Hard Blade
12	594 94 44-01	Nut,Hex,Flng. 5/16-18 Nyloc Cir	89	532 43 81-24	Arm Brake
14	532 15 60-85	Keeper Belt Idler	90	532 19 90-92	Spacer Retainer
15	592 85 47-02	CRD Idler Arm Mount Bracket	91	596 13 49-01	Washer, Plain 3/8 x 7/8
16	873 90 06-00	Nut 3/8-16	92	592 85 57-01	Rod Brake 97 CRD Link
17	596 13 48-01	Nut, Hex. 9/16-18 x 1.010	93	592 85 49-02	Arm Brake
18	532 18 76-90	Washer Spacer Mandrel	94	532 19 72-50	Bracket Clutch Cable
21	532 17 85-15	Washer Flat Hardened	96	532 40 02-71	Spacer
23	596 56 40-03	Bolt, Hex 3/8-16 x 1.75 Clr Zn	97	532 18 20-61	Shield Idler Mower
27	599 36 53-01	Belt, Deck	98	593 82 40-01	Stud, W/"D" Anti-Rotation
28	592 85 56-02	Keeper 97 CRD Angled Idler	99	532 19 51-86	Arm Suspension
33	587 81 97-01	Kit, Mandrel, Nongreasable (includes shaft and bolt)	100	532 19 65-39	Bolt Shoulder
35	532 42 79-84	Blade	103	532 43 69-92	Guard Front Vent
36	532 00 44-97	Retainer, Spring	104	592 84 81-01	Mandrel Cover RH
41	584 95 39-01	Bolt Hex Wshrhd .313-18 x 1.19	105	532 43 87-44	Mandrel Cover LH
43	532 19 74-73	Pulley Mandrel	106	532 19 32-16	Spring Brake Return
44	532 19 95-34	Pulley V-Idler GRND DR. Plated	118	599 23 63-02	Arm Clutching
47	584 30 93-01	Screw LH Blade 7/16 x 1	122	532 16 57-23	Retainer Spring
48	596 13 63-01	Bolt, Cup, Head 3/8-16 x 2	123	596 98 75-01	Bolt, 3/8 x 1-1/4" Gr.5 Clr. Zn
49	532 16 55-79	Kit, Mandrel Asm., Crd, LH Threads, Svc (includes shaft, bearing, washer, and bolt)	127	596 43 44-04	Bolt, Shoulder 3/8-16 x 3-5/8"
52	599 21 07-03	Bracket, 97crd. Centr, Idler	128	589 52 73-01	Wheel Gauge Rally
53	595 09 81-03	Bracket V-Idler Bolt Angled	--	581 57 91-01	Decal, Cutfinger
55	598 96 92-01	Keeper, 97 Crd, Clutching Arm	--	593 85 11-01	Decal, Manual Deck SVC
68	598 90 38-02	Keeper, Belt	--	596 55 13-01	Replacement Mower Complete
75	597 02 50-01	Pulley Idler Flat			

NOTE: All component dimensions given in U.S. inches
1 inch = 25.4 mm

