

Repair Parts Manual
YTH18542 / 96045005901



English

529 58 46-01



Please read the operator's manual carefully and make sure you understand the instructions before using the machine.

HOW TO USE THIS MANUAL

This manual is designed to provide the customer with a means to identify the parts on his/her tractor when ordering repair parts. The illustrations may or may not represent the actual assemblies; therefore, it is not recommended to use this manual as a guide to assemble or disassemble the tractor. Some hardware and parts are drawn larger in order to more readily identify them.

Each tractor has its own model number. The model number for your tractor can be found on the fender under the seat.

Support / Help

If you require assistance or have questions concerning the application, operation, maintenance or parts for your product:

- Visit our website: www.husqvarna.com
- Call Us Toll Free: 1-800-487-5951

When ordering parts, always give the following information:

- Product - "TRACTOR"
- MODEL NUMBER - "YTH18542" (96045005901)"
- Part Number
- Part Description

TABLE OF CONTENTS

SCHEMATIC	3
ELECTRICAL.....	4-5
CHASSIS	6-7
DRIVE.....	8-9
ENGINE.....	10-11
STEERING	12-13
MOWER DECK.....	14-15
MOWER LIFT.....	16
SEAT	17
DECALS.....	18

TRACTOR - - MODEL NUMBER YTH18542 (96045005901), PRODUCT NO. 960 45 00-59 SCHEMATIC

SCH11

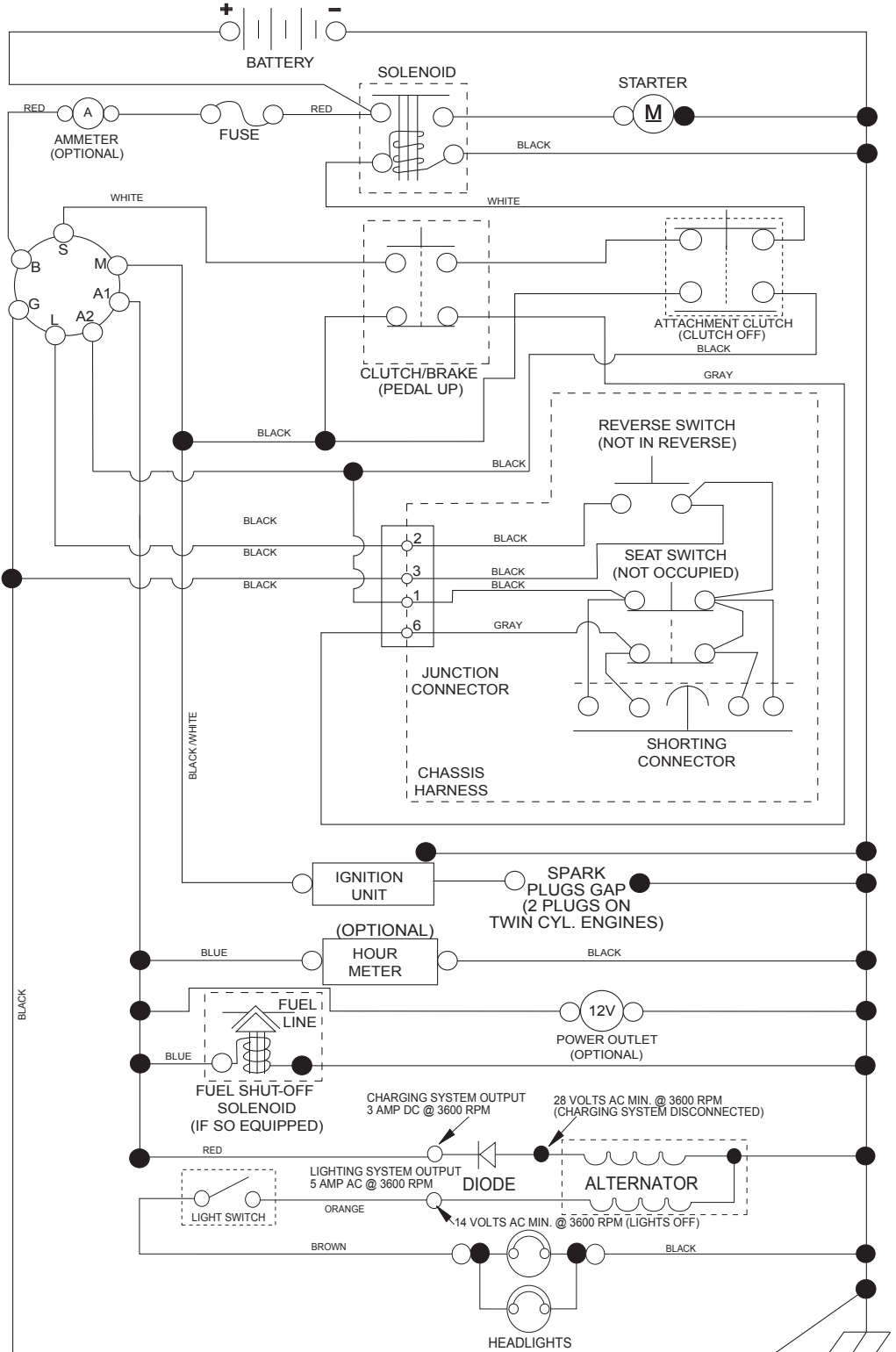

NOTE
YOUR TRACTOR IS EQUIPPED WITH A SPECIAL ALTERNATOR SYSTEM. THE LIGHTS ARE NOT CONNECTED TO THE BATTERY, BUT HAVE THEIR OWN ELECTRICAL SOURCE. BECAUSE OF THIS, THE BRIGHTNESS OF THE LIGHTS WILL CHANGE WITH ENGINE SPEED. AT IDLE THE LIGHTS WILL DIM. AS THE ENGINE IS SPEEDED UP, THE LIGHTS WILL BECOME THEIR BRIGHTEST.

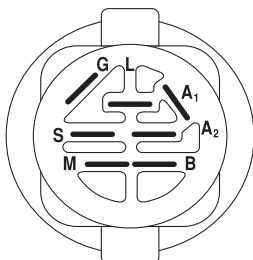

IGNITION SWITCH

POSITION	CIRCUIT "MAKE"
OFF	M+G+A1
RUN/OVERRIDE	B+A1
RUN	B+A1 L+A2
START	B+S+A1

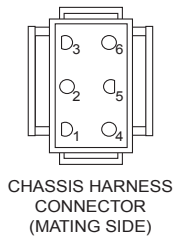

CHASSIS HARNESS CONNECTOR (MATING SIDE)



DASH HARNESS CONNECTOR (MATING SIDE)

WIRING INSULATED CLIPS
NOTE: IF WIRING INSULATED CLIPS WERE REMOVED FOR SERVICING OF UNIT, THEY SHOULD BE RE-INSTALLED TO PROPERLY SECURE YOUR WIRING.

NON-REMOVABLE CONNECTIONS

REMOVABLE CONNECTIONS

**TRACTOR -- MODEL NUMBER YTH18542 (96045005901), PRODUCT NO. 960 45 00-59
ELECTRICAL**

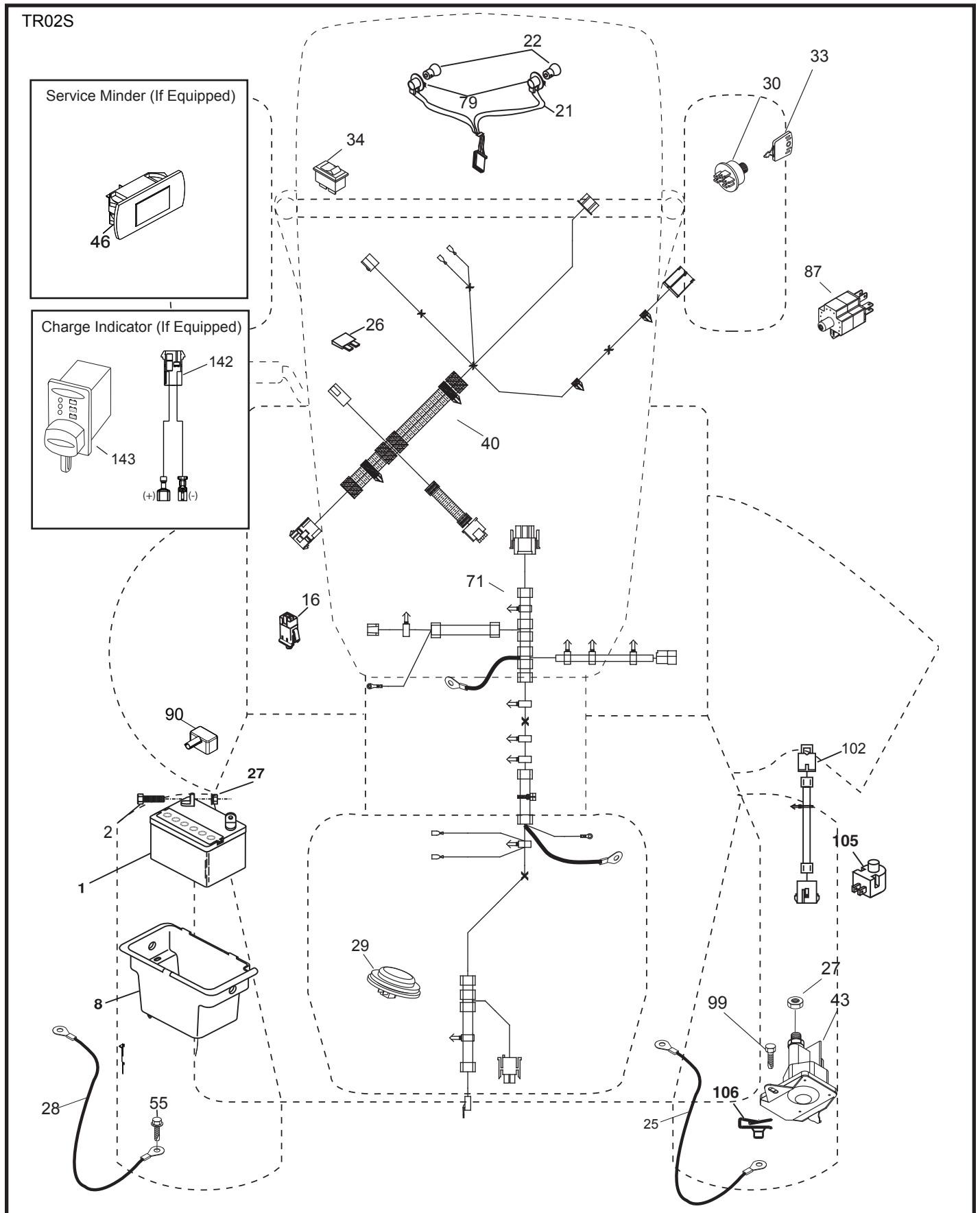

**TRACTOR -- MODEL NUMBER YTH18542 (96045005901), PRODUCT NO. 960 45 00-59
ELECTRICAL**

KEY NO.	PART NO.	DESCRIPTION
1	532 16 34-65	Battery
2	874 76 04-12	Bolt Hex Head 1/4-20 x 3/4
8	532 19 32-28	Box Battery
16	532 17 61-38	Switch Interlock Push-In
21	532 40 02-52	Harness Socket Light w/4152J
22	532 00 41-52	Bulb Light
25	581 49 80-01	Cable Starter
26	532 17 51-58	Fuse
27	596 13 36-01	Locknut, Keps. 1/4-20
28	532 42 16-86	Cable, Ground
29	532 40 15-45	Switch, Seat
30	532 19 33-50	Switch, Ign
33	532 41 19-35	Keychain, Blstrpck, Genrc, CE/CAN
34	532 11 07-12	Switch Light/Reset
40	581 02 31-01	Harness Ign. Dash
43	582 04 28-02	Solenoid, W/Brass, Plunger, ZN
55	817 06 05-12	Screw Thdrol 5/16-18 x 3/4
71	501 13 37-01	Harness Chassis
79	532 17 52-42	Socket Asm Bulb Twistlock
87	532 19 78-02	Switch Interlock Clutch Cable
90	532 43 53-95	Cover, Terminal Battery
99	817 67 04-12	Screw
102	532 40 44-54	Harness Pigtail
105	532 40 75-68	Switch Reverse
106	532 17 48-14	Pal nut

NOTE: All component dimensions given in U.S. inches
1 inch = 25.4 mm

TRACTOR -- MODEL NUMBER YTH18542 (96045005901), PRODUCT NO. 960 45 00-59
CHASSIS

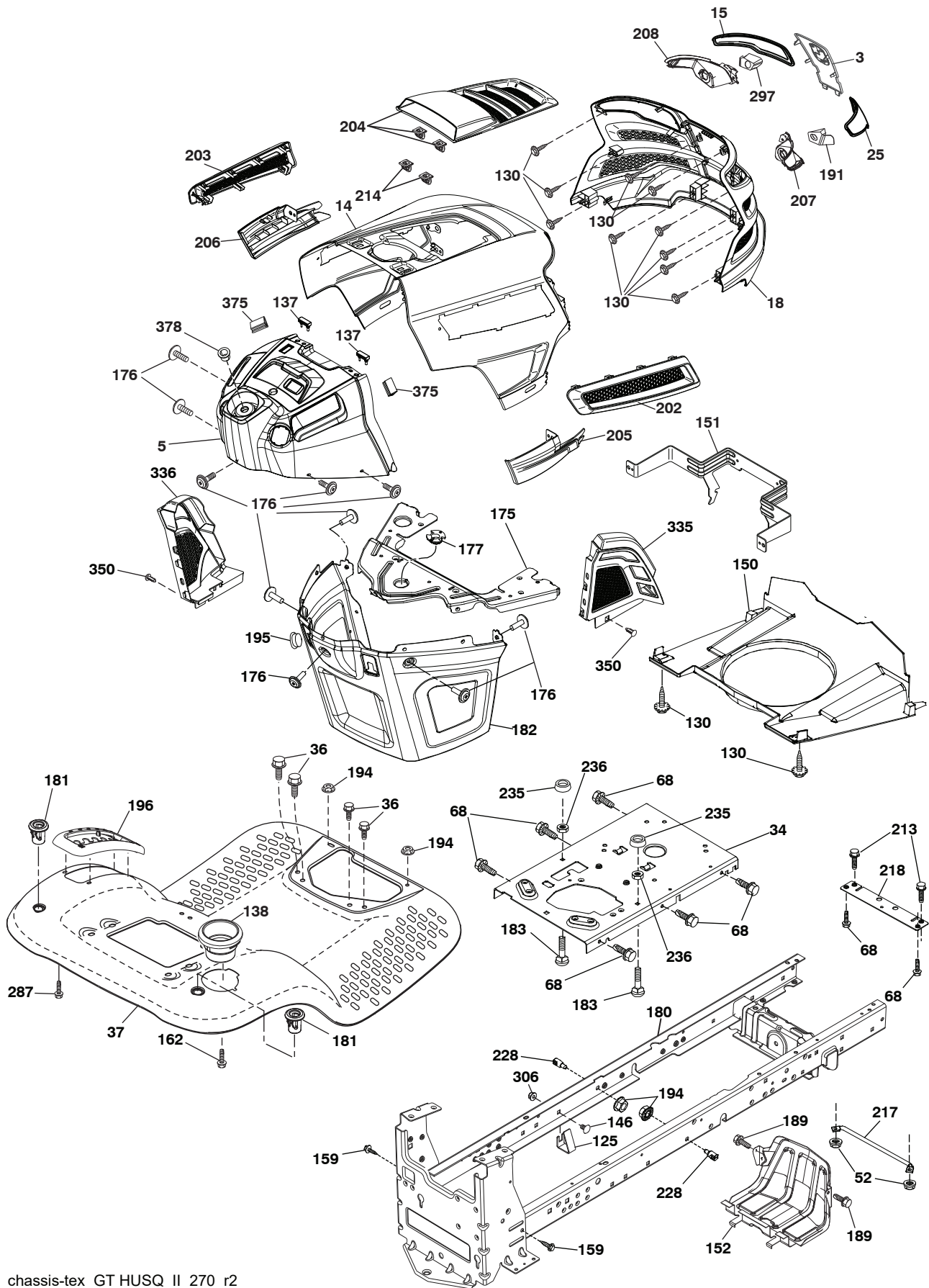

chassis-tex_GT HUSQ_II_270_r2

**TRACTOR -- MODEL NUMBER YTH18542 (96045005901), PRODUCT NO. 960 45 00-59
CHASSIS**

KEY NO.	PART NO.	DESCRIPTION	KEY NO.	PART NO.	DESCRIPTION
3	532 44 44-81	Applique Sub Asm.	194	596 13 57-01	Nutlock, Prvl, Torq. 5/16-18 x .68
5	590 74 88-18	Dash	195	532 40 41-37	Plug Dash
14	532 44 11-77	Hood	196	532 43 96-47	Console Asm. Deck Lift
15	532 43 97-33	Lens LH	202	532 43 97-28	Vent Side Hood RH
18	597 24 72-01	Grille, Asm. Gt. II, Incandescent	203	532 43 97-27	Vent Side Hood LH
25	532 44 33-85	Lens RH	204	587 48 58-01	Vent, Top, Asm.
34	580 91 08-01	Plate Engine	205	532 43 97-30	Trim Side RH
36	817 06 05-12	Screw 5/16-18 x 3/4	206	532 43 97-29	Trim Side LH
37	532 44 12-06	Fender	207	587 46 48-01	Bezel RH
52	596 04 05-01	Nutlock, Hex. Prvl. 5/16-18	208	587 46 45-01	Bezel LH
68	596 03 07-01	Screw, Hexagon, 5/16-18 x 1/2	213	596 03 05-01	Bolt, Hex. Hd. 5/16-18 unc x 3/4
125	581 68 48-01	Clip Fuel Line	214	532 19 91-45	Clip Retainer
130	596 32 17-01	Screw, #10 x 0.750 BOS Thread	217	532 40 91-67	Rod Pivot Hood
137	532 40 75-90	Bumper Dash	218	532 19 63-95	X-Piece Hood Stop
138	532 43 97-47	Cupholder	228	593 82 40-01	Stud, W/"D" Anti-rotation
146	581 85 79-01	Bolt RDHD SHT SQNK 3/8-16 x 5/8	235	596 56 42-01	Spacer, Fender, Clr. Zn
150	532 43 99-21	Air Duct	236	873 93 05-00	Nut Lock 5/16-18 unc
151	532 43 66-70	Hood Pivot Bracket	287	817 60 04-06	Screw Hex Washhead 1/4-20 x 3/8
152	532 43 98-70	Shield Browning	297	532 43 74-56	Insert Reflective LH
159	817 00 06-12	Screw Hexwash Thor 3/8-16 x 3/4	306	873 90 06-00	Nut Lock Flg 3/8-16 unc
162	596 13 41-01	Screw, Hex. Tap. 1/4-15 x 1/2	335	532 44 82-04	Cover RH
175	590 60 77-02	Crossmember Plate	336	532 44 53-09	Cover LH
176	532 40 07-76	Screw 10-24 x 5/8	350	532 44 51-43	Clip X-mas Tree
177	532 19 52-28	Bushing Steering	375	586 90 82-01	Dash Clip-On Bumper
180	532 19 54-57	Chassis	378	590 84 98-01	Bushing, Flange, Plastic
181	532 43 97-46	Bushing Mtg. Fender Crgo	336	587 25 96-02	Bolt 5/16-18 x 1-3/4 Flanged
182	586 73 86-02	Dash Lower	--	532 43 99-76	Dash Plug Reminder
183	595 30 57-01	Screw, Hexagon, 5/16-18 x 1-1/4			
189	817 00 05-12	Screw 5/16-18 x 3/4			
191	532 43 74-55	Insert Reflective RH			

NOTE: All component dimensions given in U.S. inches
1 inch = 25.4 mm

**TRACTOR -- MODEL NUMBER YTH18542 (96045005901), PRODUCT NO. 960 45 00-59
DRIVE**

KEY NO.	PART NO.	DESCRIPTION	KEY NO.	PART NO.	DESCRIPTION
1	-- -- -- --	Transaxle, TUFFTORQ K46 BT (426120) (Order parts from trans-axle manufacturer.)	170	532 19 43-22	Keeper Belt Centerspan
2	532 12 35-83	Key	171	596 13 63-01	Bolt, Cup Head, 3/8-16 x 2
15	596 56 53-01	Washer, 3/8 x 0.08 in. St. Clr. Zinc	177	587 22 53-01	Pin, Cotter, Locking, Bowtie, 1 In.
17	532 41 36-78	Spring Brake	183	532 13 70-57	Spacer Split
29	532 40 38-06	Rod, Brake	184	587 65 37-01	Handle Parking Brake
33	812 00 00-01	Ring E	185	872 11 06-22	Bolt Rdhd. Sqnk. 3/8-16x2-3/4 Gr. 5
35	590 60 59-02	Rod Brake Park	186	532 19 43-21	Spacer Retainer
37	532 18 89-67	Washer Hardened	187	596 13 55-01	Washer, 13/32 x 2 Clear, Zinc
42	532 00 88-83	Cover Foot Pedal	188	582 21 70-01	Link Clutch Ground Drive, Long
49	596 13 62-01	Bolt, Cup Head, 3/8-16 x 3/4	189	532 19 43-17	Bellcrank Ground Drive
50	532 19 43-27	Pulley Idler Flat	190	532 19 43-18	Keeper Bellcrank Ground Drive
51	873 90 06-00	Lock Nut 3/8-16	205	532 12 17-48	Washer
52	532 19 43-26	Idler V-Groove	210	532 40 09-80	Rocker Asm Pedel Control
56	592 85 52-01	V-Belt Drive	211	532 12 01-83	Bearing Nylon
64	532 19 78-65	Shaft Asm. Pedal Brake Control	214	532 42 12-63	Pedal Forward Pad
69	532 42 33-03	Hairpin	215	586 60 65-02	Pedal Reverse
73	596 13 65-01	Bolt, Hex. Head, 5/16-18 x 1-1/2	216	532 19 61-31	Bracket Pulley Idler
92	595 30 57-01	Screw, Hexagon, 5/16-18 x 1-1/4	221	532 40 31-87	Retainer Spring Clip Handle
99	582 40 45-01	Rod Asm. Bypass	222	879 21 20-10	Washer 21/32 x 1-1/4 10 Ga.
116	596 13 57-01	Nutlock, Prvl. Torq. 5/16-18 x .68	223	598 66 26-01	Bolt, T45, 5/16-18x .75m Hexhd, Blk
125	817 00 05-12	Screw 5/16-18 x 3/4	225	532 40 33-19	Keeper Belt Trans.
143	596 03 07-01	Screw, Hexagon, 5/16-18 x 1/2	227	596 13 59-01	Bolt, Hex. 5/16-18 x 3/4 Clr. Znc.
153	532 00 44-97	Retainer Spring	325	585 66 85-02	Torque Strap K46 LT RH
159	596 02 95-01	Pin, Cotter, 1/8 Dia. x 3/4	326	585 67 08-02	Bracket TRQ STP 46 20" Tire RH
161	532 10 57-09	Spring Return Clutch	336	587 25 96-02	Bolt, 5/16-18 x 1-3/4, Flanged
163	593 86 10-01	Rod, Control, K46/K57R			
166	532 42 91-64	Nut Push			
167	532 40 52-57	Latch Brake Parking			

NOTE: All component dimensions given in U.S. inches
1 inch = 25.4 mm

**TRACTOR -- MODEL NUMBER YTH18542 (96045005901), PRODUCT NO. 960 45 00-59
ENGINE**

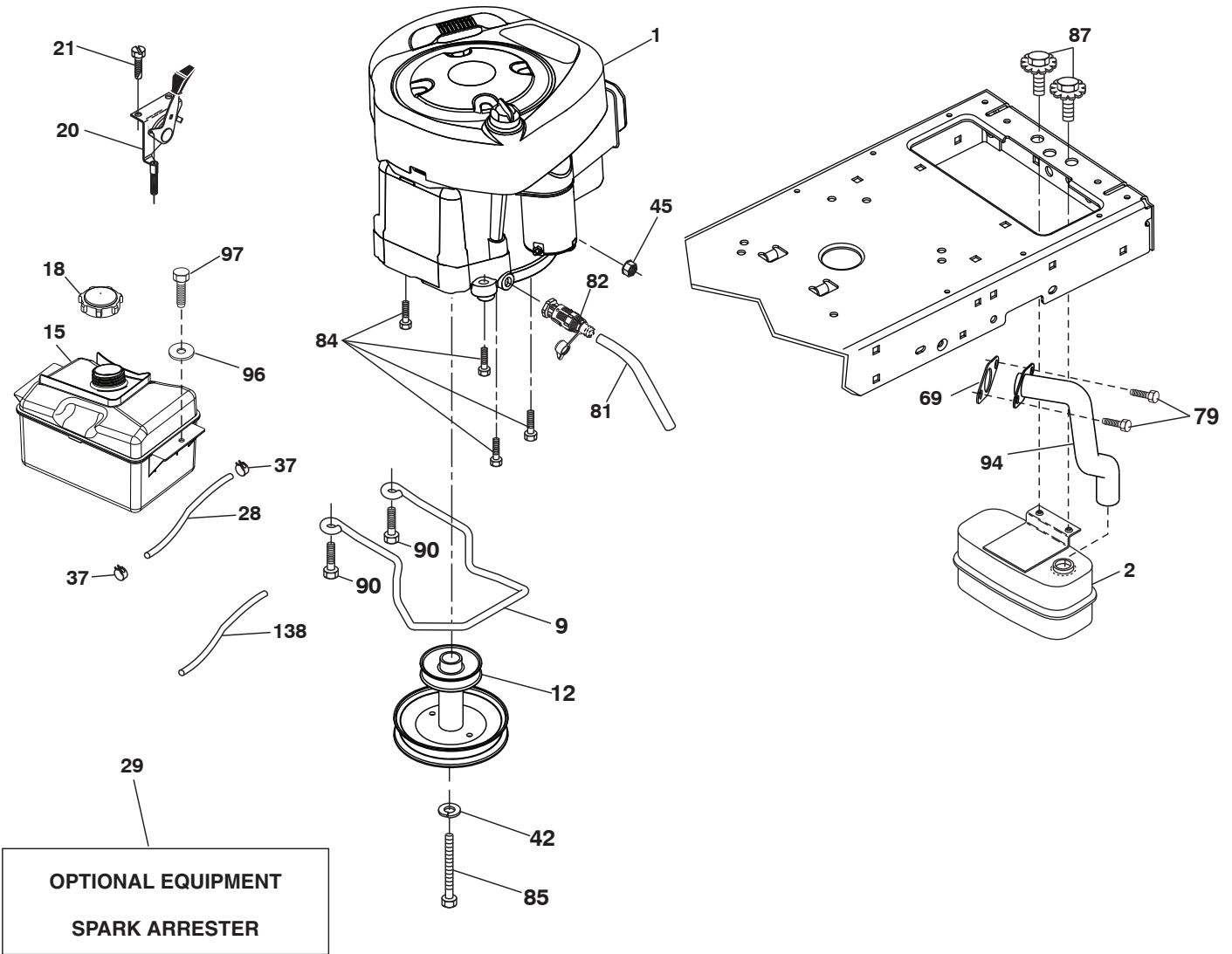

engine-tex_BS_134

TRACTOR -- MODEL NUMBER YTH18542 (96045005901), PRODUCT NO. 960 45 00-59 ENGINE

KEY NO.	PART NO.	DESCRIPTION
1	---	Engine Briggs Model No. 33R777-0005-G1(586306801) (Order parts from engine manufacturer.)
2	590 64 53-01	Muffler
9	501 83 26-02	Keeper Belt Engine
12	586 47 85-01	Pulley Engine
15	597 95 45-01	Fuel, Tank, Asm. 2.5 Ga.
18	581 17 61-01	Cap Fuel
20	532 18 38-97	Control Throttle
21	596 32 17-01	Screw, #10 x 0.750 BOS Thread
28	532 40 11-37	Fuel Line
29	532 13 71-80	Spark Arrester Kit
37	532 12 34-87	Clamp Hose
42	596 23 89-01	Washer, 7/16 in. Clr. Zn
45	596 13 36-01	Locknut, Keps. 1/4-20
69	532 16 52-91	Gasket
79	596 13 42-01	Screw, Hex. Socket, 5/16-18 x 3/4
81	532 14 84-56	Tube Drain Oil Easy
82	532 42 82-87	Valve Drain Oil
84	817 06 06-20	Screw 3/8-16 x 1/4
85	501 60 65-01	Bolt Hex 7/16-20 x 4 Gr. 5
87	532 17 18-77	Bolt 5/16-18 unc x 3/4 w/sems
90	817 00 06-16	Screw 3/8-16 x 1
94	581 88 09-01	Exhaust Tube
96	596 13 53-01	Washer, Plain, 9/32 x 7/8 Clr. Zn
97	817 67 04-12	Screw 1/4-20 x 3/4
138	596 94 15-01	Tube, Purge, Fuel .1875"

NOTE: All component dimensions given in U.S. inches
1 inch = 25.4 mm

For engine service and replacement parts, call the toll free number for your engine manufacturer listed below:

Briggs & Stratton 1-800-233-3723

Engine Power Rating Information

The gross power rating for individual gas engine models is labeled in accordance with SAE (Society of Automotive Engineers) code J1940 (Small Engine Power & Torque Rating Procedure), and rating performance has been obtained and corrected in accordance with SAE J1995 (Revision 2002-05). Torque values are derived at 3060 RPM; horsepower values are derived at 3600 RPM. Actual gross engine power will be lower and is affected by, among other things, ambient operating conditions and engine-to-engine variability. Given both the wide array of products on which engines are placed and the variety of environmental issues applicable to operating the equipment, the gas engine will not develop the rated gross power when used in a given piece of power equipment (actual "on-site" or net power). This difference is due to a variety of factors including, but not limited to, accessories (air cleaner, exhaust, charging, cooling, carburetor, fuel pump, etc.), application limitations, ambient operating conditions (temperature, humidity, altitude), and engine-to-engine variability. Due to manufacturing and capacity limitations, Briggs & Stratton may substitute an engine of higher rated power for this Series engine.

TRACTOR -- MODEL NUMBER YTH18542 (96045005901), PRODUCT NO. 960 45 00-59
STEERING ASSEMBLY

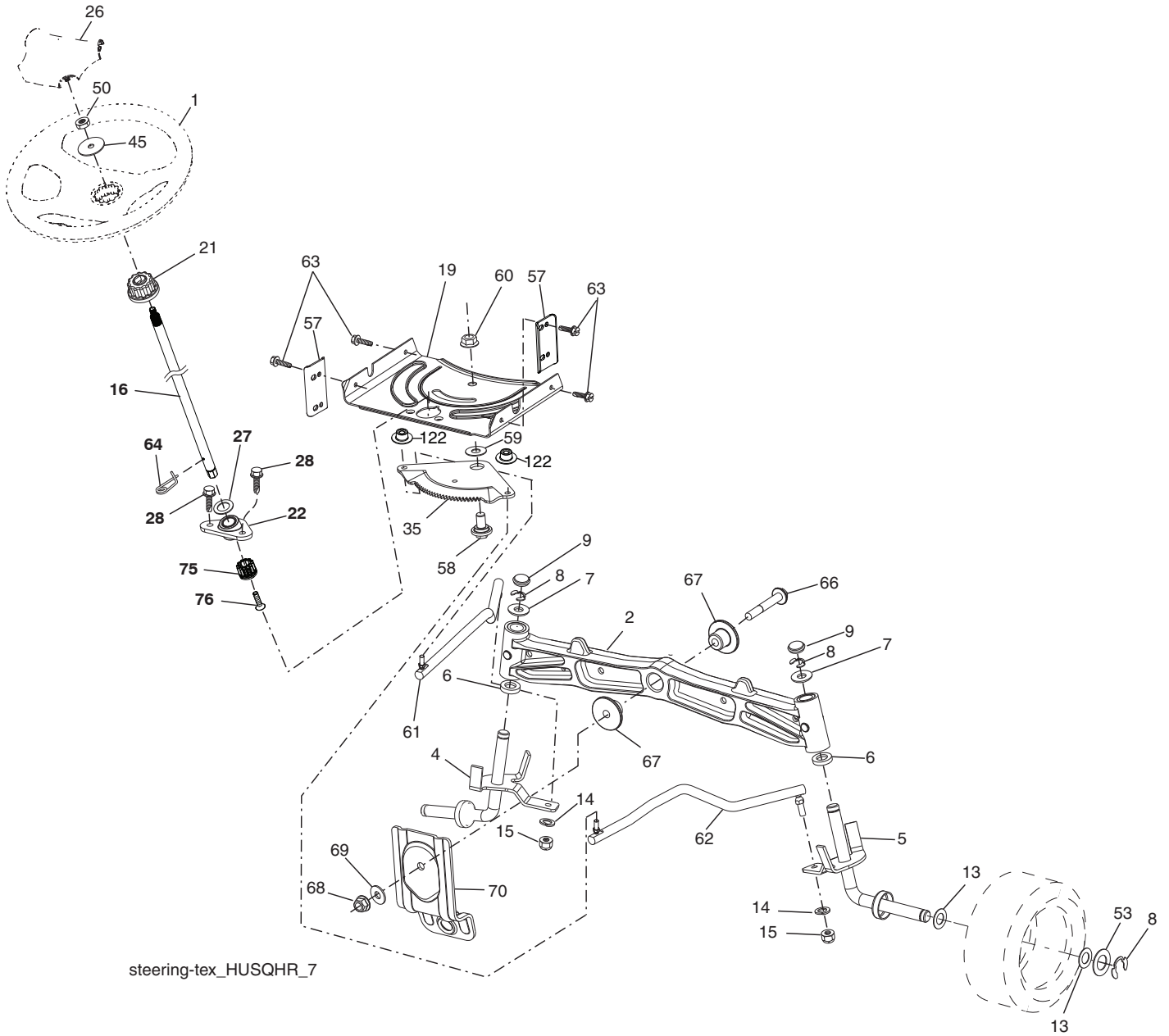

steering-tex_HUSQHR_7

**TRACTOR -- MODEL NUMBER YTH18542 (96045005901), PRODUCT NO. 960 45 00-59
STEERING ASSEMBLY**

KEY NO.	PART NO.	DESCRIPTION
1	532 43 99-97	Wheel, Steering
2	532 19 59-68	Axle Asm., Front
4	532 40 30-87	Spindle Asm., LH
5	532 40 30-88	Spindle Asm., RH
6	532 00 62-66	Washer, Thrust .75 x 1.230
7	532 12 17-48	Washer 25/32 x 1-5/8 x 16 Ga.
8	812 00 00-29	Ring, Klip #T5304-75
9	532 12 12-32	Cap, Spindle
13	532 12 17-49	Washer 25/32 x 1-1/4 x 16 Ga.
14	596 23 87-01	Washer, Spring, Lock, .381 ID x .680
15	873 54 06-00	Nut, Crown Lock 3/8-24 unf
16	587 01 60-02	Shaft Steering
19	532 19 47-29	Plate Steering
21	586 84 02-01	Adapter Wheel Steering
22	585 02 98-02	Bearing
26	532 43 97-43	Insert, Wheel Steering
27	596 93 34-01	Washer, Plain
28	817 00 06-12	Screw 3/8-16 x 3/4
35	532 19 47-32	Gear, Sector Plate
45	587 01 64-01	Washer 3/8 ID 2-3/8 OD 12 Ga. PLTD
50	873 90 06-00	Nut Lock Flg 3/8-16 unc
53	532 18 89-67	Washer Hardened .793 x 1.637 x .060
57	532 40 74-65	Bracket Upstop
58	532 19 47-47	Bolt Shoulder Sector Pivot CFM
59	532 19 47-48	Washer Thrust Sector Steering
60	873 97 10-00	Nut Flange Lock 5/8-11
61	597 04 78-02	Draglink, LH. Ballstud, Std.
62	597 04 79-02	Draglink, RH. Ballstud, Std.
63	817 00 05-12	Screw 5/16-18 x 3/4
64	532 19 98-49	Retainer Clip Spring Steering
66	871 02 07-48	Bolt Hex Fghd 7/16-14 x 3 Serr
67	532 19 47-37	Bushing PM Front Axle
68	873 90 07-00	Nut Lock Flange 7/16-14 Gr. 5
69	532 19 91-62	Washer 1.5 x .505 x .118
70	585 33 88-01	Bracket Deck Susp. Front
75	580 68 37-01	Pinion
76	580 68 36-01	Screw Head Sock
122	532 44 49-62	Cap Gear Sector

NOTE: All component dimensions given in U.S. inches
1 inch = 25.4 mm

**TRACTOR -- MODEL NUMBER YTH18542 (96045005901), PRODUCT NO. 960 45 00-59
MOWER DECK**

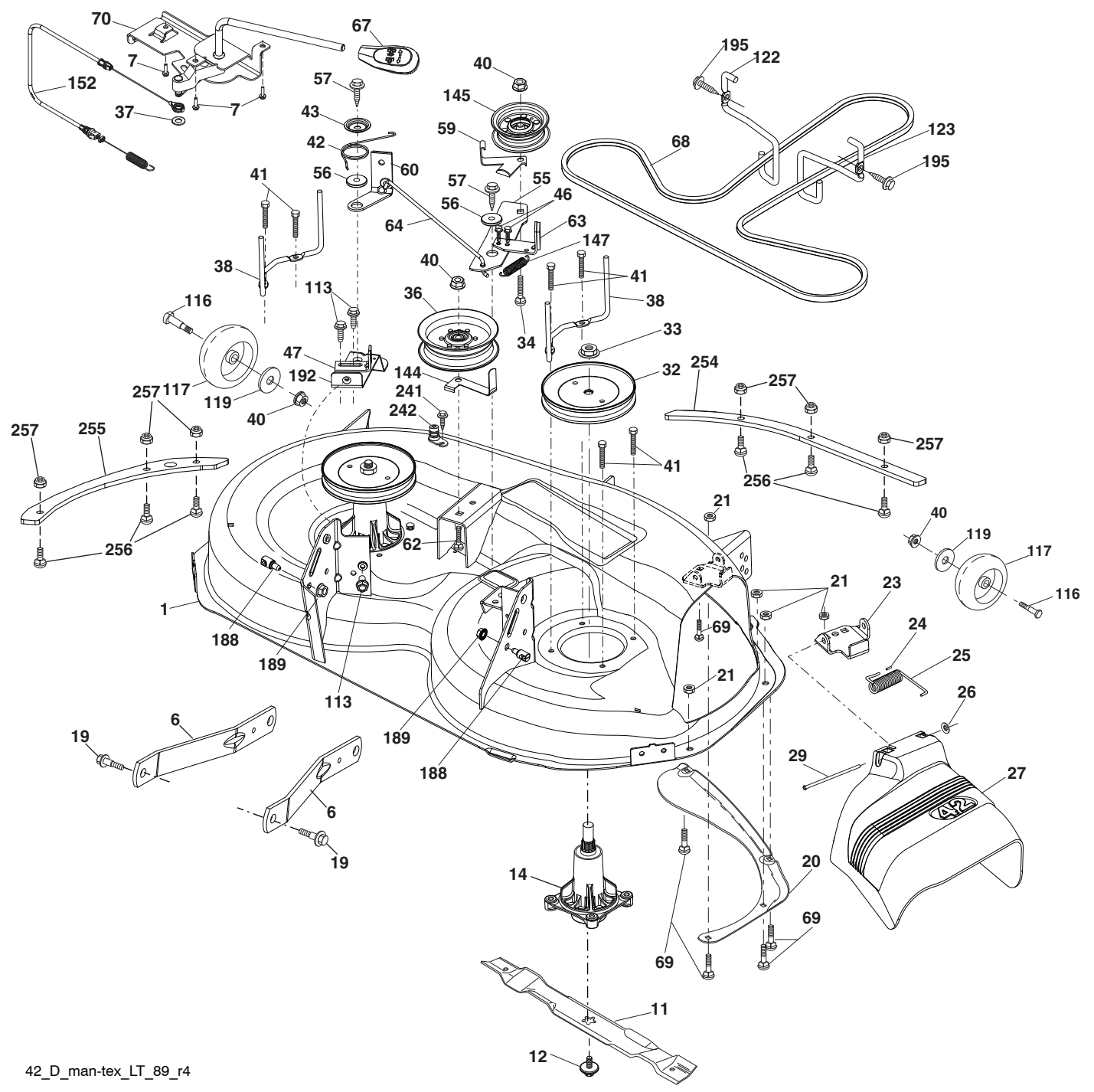

42_D_man-tex_LT_89_r4

**TRACTOR -- MODEL NUMBER YTH18542 (96045005901), PRODUCT NO. 960 45 00-59
MOWER DECK**

KEY NO.	PART NO.	DESCRIPTION	KEY NO.	PART NO.	DESCRIPTION
1	532 44 78-95	Kit, SVC, Weldment	62	596 13 63-01	Bolt, Cup Head, 3/8-16 x 2
6	532 19 51-86	Arm Suspension	63	532 19 94-77	Arm Brake Mower
7	596 32 17-01	Screw, #10 x 0.750 BOS Thread	64	532 19 99-18	Link Brake
11	532 13 89-71	Blade, 42" Hi-Lift (For bagging or discharge)	67	532 40 30-12	Handle Clutch Cable
12	584 30 93-01	Screw	68	598 55 91-01	Belt, Deck, 101.25 EL
14	587 81 97-01	Kit, Mandrel, Nongrease, Tall (inlcudes shaft and bolt)	69	596 13 64-01	Bolt, Cup Head, 5/16-18 x 5/8
19	532 19 65-39	Bolt, Shoulder	70	532 19 99-72	Clutch Asm Manual
20	532 15 97-70	Baffle, Vortex	113	817 00 05-10	Screw 5/16-18
21	596 04 05-01	Nutlock, Hex. Prvl. 5/16-18	116	596 43 44-02	Bolt, Shldr. 2.41 x 1.66 x 5" Clr. Zn.
23	532 19 25-57	Bracket, Deflector	117	589 52 74-01	Wheel, Gauge
24	532 10 53-04	Cap, Sleeve	119	596 13 49-01	Washer, Plain 3/8 x 7/8
25	532 19 70-26	Spring, Torsion, Deflector	122	532 19 72-58	Keeper Belt Engine LH
26	532 11 04-52	Nut, Push	123	532 19 72-59	Keeper Belt Engine RH
27	532 40 30-04	Shield, Deflector	144	532 19 92-04	Keeper Belt
29	595 29 70-01	Rod, Hinge	145	532 19 31-97	Pulley Idler
32	532 19 74-73	Pulley, Mandrel	147	532 40 19-71	Spring Return
33	596 13 48-01	Nut, Hex. 9/16-18 x 1.010	152	584 24 35-01	Manual Clutch Cable
34	596 13 61-01	Bolt, Cup Head, 3/8-16 x 1-1/2"	188	593 82 40-01	Stud, W/"D" Anti-rotation
36	532 19 73-79	Pulley, Idler, Flat	189	596 13 57-01	Nutlock, Prvl. Torq. 5/16-18 x .68
37	596 56 53-01	Washer, 3/8 x 0.08 in. St. Clr. Zinc	192	532 19 72-60	Bracket Brake Stand LH
38	589 67 61-02	Keeper Belt Mandrel	195	817 00 06-12	Screw 3/8-16 x 3/4
40	873 90 06-00	Nut, Lock Flg. 3/8-16 unc	241	532 15 29-27	Screw TT #10-32 5 3/8 Flange
41	584 95 39-01	Bolt Hex Wshrhd 3/16-18 x 1.19	242	532 41 55-98	Port Washout
42	532 19 84-10	Spring Torsion Brake	254	585 31 68-05	Plate Reinforcment Front
43	532 19 72-56	Spring Torsion Retainer	255	585 31 70-05	Plate Reinforcement Side
46	532 13 77-29	Screw Thd Roll 1/4-20 x 5/8	256	592 80 78-01	Bolt 1/4-20X1".Zn. Square Neck
47	532 19 72-50	Bracket Clutch Cable	257	873 90 04-00	Nut Hex Flange 1/4-20 unc
55	532 43 71-10	Arm, Idler	--	532 41 64-05	Coupling Quick connect
56	532 19 90-92	Spacer, Retainer	--	532 44 78-93	Replacement Mower, Complete
57	817 00 06-16	Screw 3/8-16 x 1			
59	532 14 10-43	Guard, Tuv Idler			
60	532 19 72-61	Arm Brake Mower			

NOTE: All component dimensions given in U.S. inches
1 inch = 25.4 mm

**TRACTOR -- MODEL NUMBER YTH18542 (96045005901), PRODUCT NO. 960 45 00-59
MOWER LIFT**

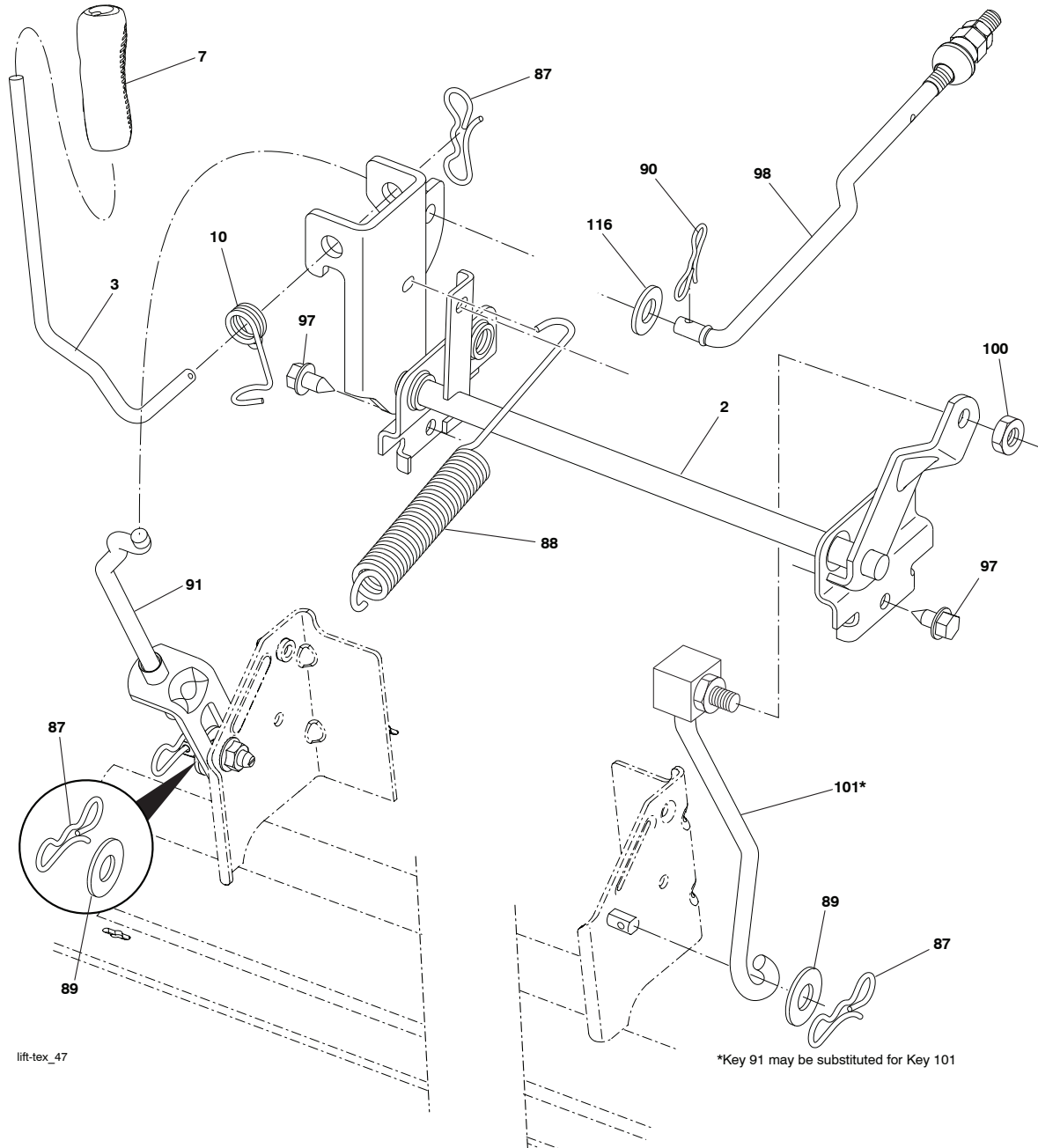

lift-tex_47

*Key 91 may be substituted for Key 101

KEY NO.	PART NO.	DESCRIPTION
2	532 42 20-27	Shaft Asm., Lift
3	594 01 80-01	Handle, Liftlever, Lt, Std, Wide
7	580 96 23-01	Grip, Lever
10	532 19 63-14	Spring Torsion
87	532 19 42-09	Pin Cotter 7/16 Bow Tie Lock
88	532 41 07-10	Spring Lift Assist
89	819 19 19-12	Washer Clear Zinc
90	532 19 42-08	Pin Cotter 5/16 Bow Tie Lock
91	589 46 48-03	Link, Assy. Lift, Rear

KEY NO.	PART NO.	DESCRIPTION
97	817 00 06-12	Screw Hex Wsh. THDR 3/8-16 x 3/4
98	581 50 69-03	Link, Assy. Mwr. Front, Suspension
100	595 30 59-01	Nut, Hex. Locknut, 3/8-16
101	532 40 70-03	Link Asm. Fixed
116	594 97 65-01	Washer 15/32 x 15/16 x .065

NOTE: All component dimensions given in U.S. inches
1 inch = 25.4 mm

**TRACTOR -- MODEL NUMBER YTH18542 (96045005901), PRODUCT NO. 960 45 00-59
SEAT ASSEMBLY**

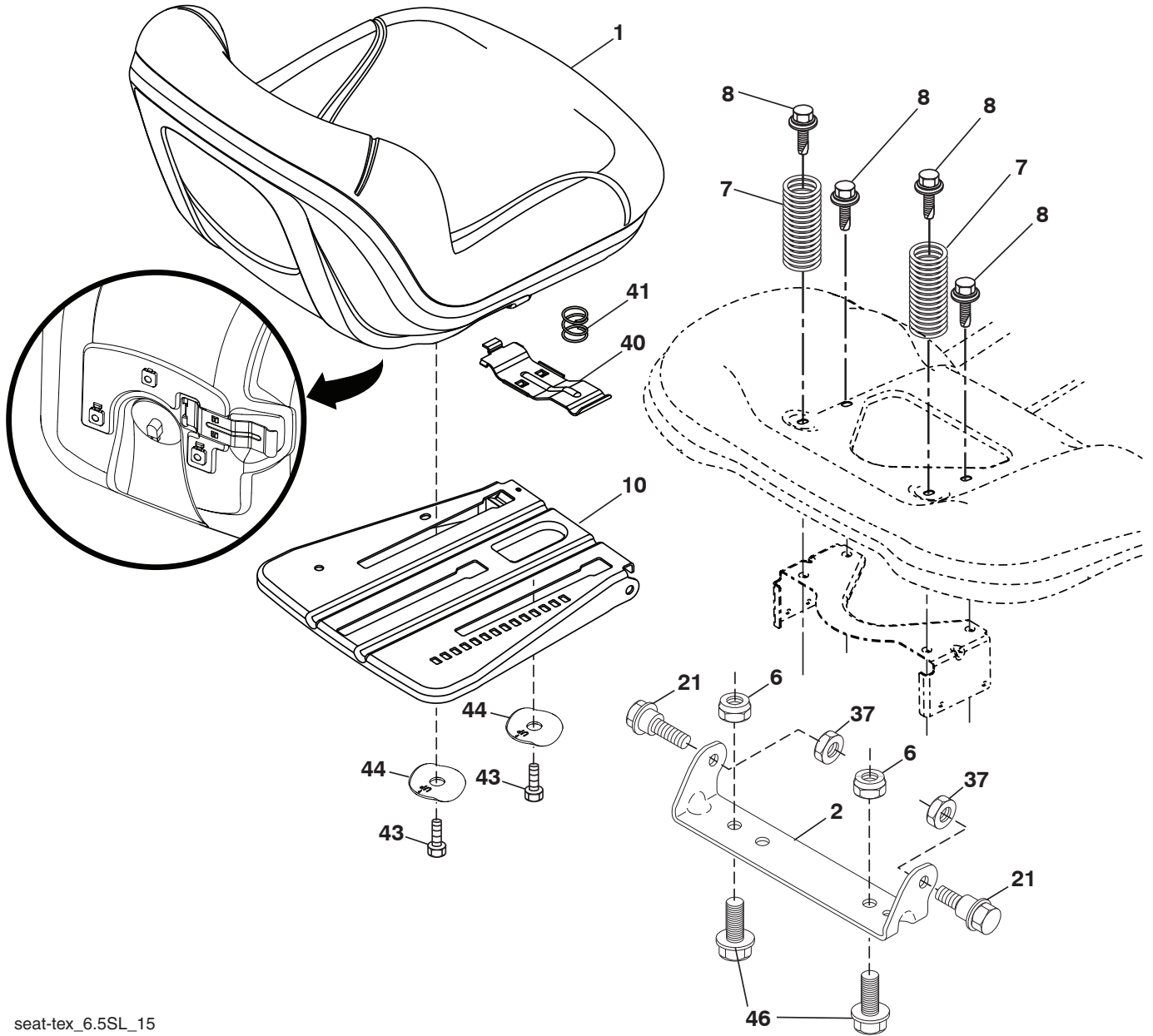

seat-tex_6.5SL_15

KEY NO.	PART NO.	DESCRIPTION
1	532 43 98-19	Seat
2	532 18 01-66	Bracket Pivot Fender
6	873 80 06-00	Nut, Lock w/Ins. 3/8-16 unc
7	589 48 35-01	Spring, Seat Cprsn
8	532 17 18-77	Bolt 5/16-18 unc x 3/4 w/Sems
10	596 65 74-02	Plate, Seat
21	587 90 78-01	Bolt, Shoulder 5/16-18 x 5/8
37	596 58 37-02	Nut, Hex, 5/16-18 Nyloc, Blk_Zinc
40	595 08 81-02	Handle, Seat, Slide, E-Dip, x 431

KEY NO.	PART NO.	DESCRIPTION
41	532 19 82-00	Spring Latch Seat
43	874 76 06-12	Bolt Fin Hex 3/8-16 unc x 3/4
44	501 05 18-01	Washer Winged
46	588 09 04-01	Bolt 3/8-16 x 1, 1.25 OD

NOTE: All component dimensions given in U.S. inches
1 inch = 25.4 mm

**TRACTOR -- MODEL NUMBER YTH18542 (96045005901), PRODUCT NO. 960 45 00-59
DECALS**

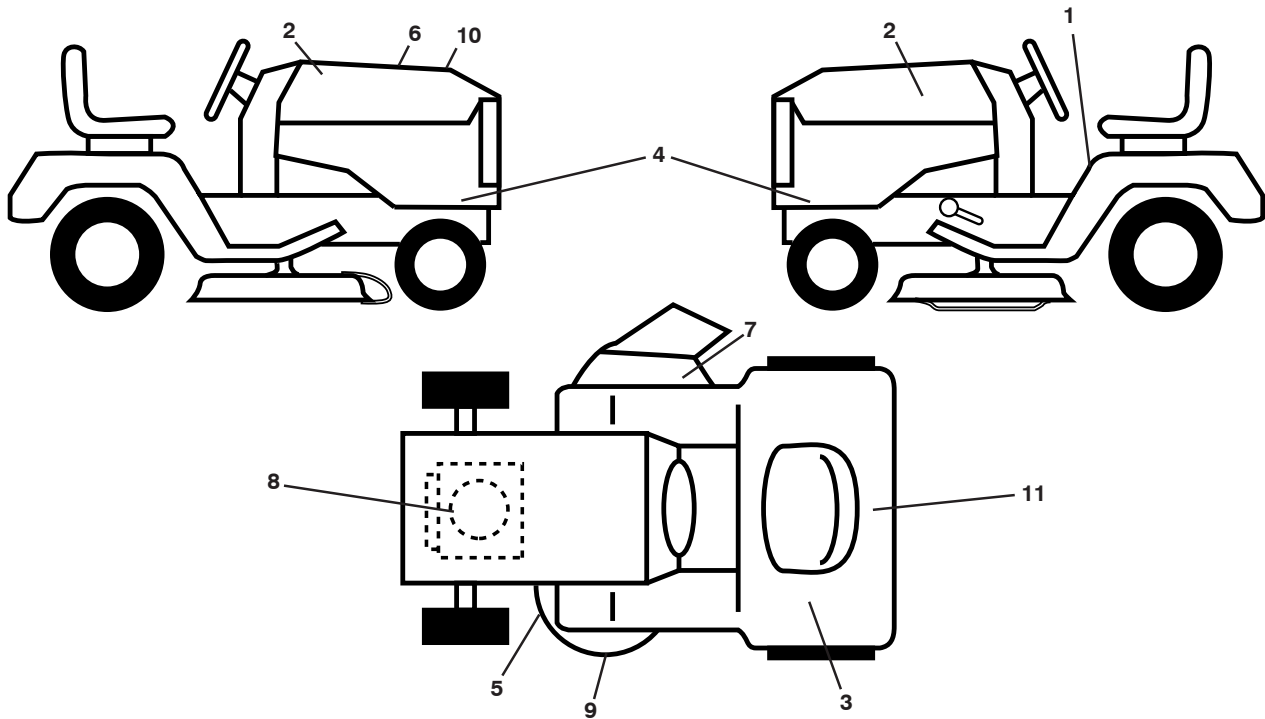

KEY NO.	PART NO.	DESCRIPTION
1	581 57 90-01	Decal, Fender, Warning, Eng/Fr/Sp
2	581 62 73-01	Decal, Hood Logo
3	529 40 53-01	Decal, Deck, Built In America. Husq
4	585 98 62-01	Decal, Hood Panel
5	581 58 00-01	Decal, Mower V-Belt Schematic
6	529 53 74-01	Decal, Rpl. Bsm33. Intk. Tlw. K46
7	584 90 46-01	Decal, Deflect. Warning
8	585 55 60-01	Decal, Engine
9	599 96 68-01	Decal, Deck, Stamp, Bioclipcmp. Hu
10	580 88 58-01	Decal, E85 Warning
11	596 62 34-01	Decal, Instru. Dealerhusq. Eng/Fr
--	581 72 48-01	Decal, Bypass

KEY NO.	PART NO.	DESCRIPTION
--	532 43 96-81	Pad, Footrest, LH
--	532 43 96-82	Pad, Footrest, RH
--	114-25 65-24	Manual, Opers. 96045005901. (English/Spanish)
--	114 25 66-32	Manual, Opers. 96045005901. (English/French)
--	529 58 46-01	Manual, parts, 96045005901. (English)
--	587 71 00-26	Manual, Quick Start Guide (English/Spanish)
--	587 71 01-26	Manual, Qsg. Husqvarna, (English/French)

WHEELS AND TIRES

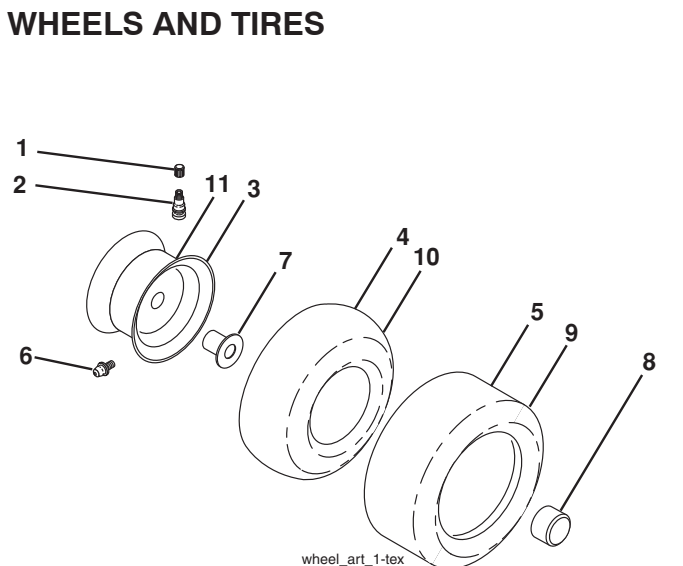

KEY NO.	PART NO.	DESCRIPTION
1	532 05 91-92	Cap Valve Tire
2	532 06 51-39	Stem Valve
3	532 13 83-36	Rim Asm 6" Front
4	532 05 99-04	Tube Front (Service Item Only)
5	532 10 62-22	Tire Front 15 x 6-6
6	532 00 02-78	Fitting Grease (Front Wheel Only)
7	532 00 90-40	Bearing Flange (Front Wheel Only)
8	532 17 50-39	Cap Axle
9	532 13 84-68	Tire Rear 20 x 8-8
10	532 00 71-52	Tube Rear (Service Item Only)
11	532 13 83-37	Rim Asm 8" Rear
--	532 14 43-34	Sealant, Tire (10 oz. Tube)

NOTE: All component dimensions given in U.S. inches
1 inch = 25.4 mm

NOTES



www.husqvarna.com