

Illustrated Parts List - IPL Update



Product Name(s)

372 XP X-TORQ

Description of change

1. New crank shaft assy. with new big end bearing with a more robust cage.
2. New screw with torx grip T10 to knee joint, chip guard, cover, spike, chain guide, grounding cable and chain guide plate provides better condition for tightening.

Comments

Fully interchangeable

Introduced from

Serial number / Date	Remark
20172301113 -	Crank shaft assy. 503 74 87-05
20164600385 -	Screw CITXPANT 525 88 74-02

IPL updates

Page Title	Ref. No	New part no	Name	Excl. part no.	Remark
CRANK SHAFT	1	503 74 87-05	Crank shaft assy.	503 74 87-04	
CHAIN BRAKE	4	525 88 74-02	Screw CITXPANT	503 21 28-10	
CLUTCH COVER	4,14,19	525 88 74-02	Screw CITXPANT	503 21 28-10	
CLUTCH COVER	4,13,16,18	525 88 74-02	Screw CITXPANT	503 21 28-10	
IGNITION SYSTEM	23	525 88 74-02	Screw CITXPANT	503 21 28-10	
CRANK CASE	9	525 88 74-02	Screw CITXPANT	503 21 28-10	

1. Crank shaft assy.

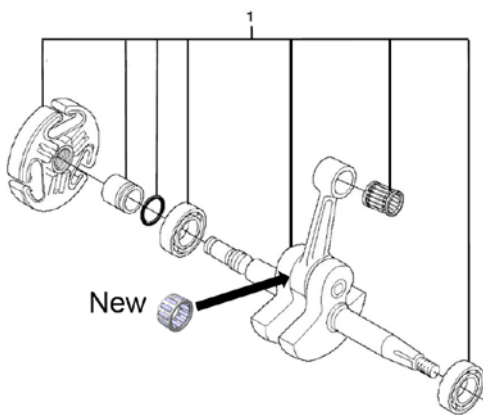

503 74 87-05

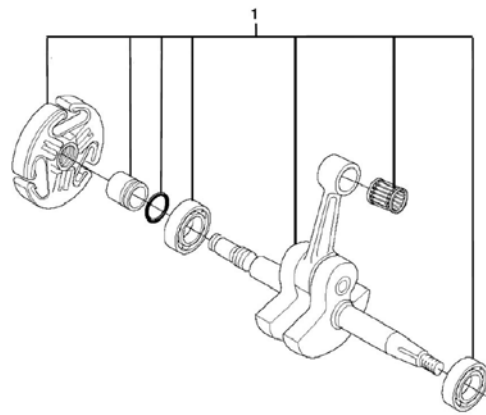

503 74 87-04

Illustrated Parts List - IPL Update



2. Screw

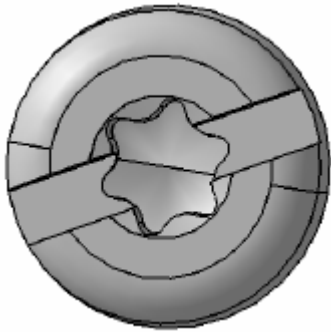

525 88 74-02

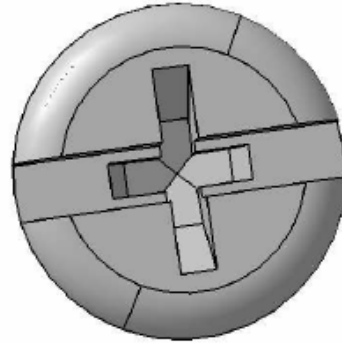

503 21 28-10