

# Illustrated part list IPL update

## Instruction

Husqvarna Division; Handheld

Husqvarna



Product Name(s)

**H560XP/XPG**

### Description of change

1. We have removed the label 535 05 80-01 on Clutch cover assy and added a moulded logo "Husqvarna". New colour: **Metallic Rough**.
2. New forged adapter has been implemented on the Clutch drum, the new Worm wheel has a new design due to this new adapter. The old Worm wheel 505 20 08-01 will **NOT** fit the new Clutch drum, and new Worm wheel will **NOT** fit the old Clutch drum.
3. New Oil pump 505 19 99-08 with increased diameter has been introduced to fit the new Clutch drum. New colour: **Natural**.

New Clutch drum assy Kit, 598 93 77-01/-02 is added. The Kit consist of: The new Clutch drum assy, new Oil pump and new Worm wheel.

4. A new Ball bearing 525 43 42-04 is replacing -03. New Crankshaft 575 54 52-17 has an additional Ball bearing 525 43 42-04 and a Protective cap 596 91 13-01.
5. A new Crankcase assy 575 38 02-22 has been implemented with a new Fly wheel side and an additional Ball bearing 525 43 42-04. New colour: **Metallic Rough**.

Page H2 added with Shortblock 580 66 37-11.

6. We have introduced a Protective cap 596 91 13-01 to prevent dirt from getting into the crankcase. **NOTE:** Can only be used on new Crankcase assy 575 38 02-22 and Shortblock 580 66 37-11.

### Comments

1. Clutch cover assy 501 84 61-01 is fully exchangeable. New colour: **Metallic Rough**.
2. Clutch drum and Worm wheel are **NOT** exchangeable.
3. Oil Pump is fully exchangeable. New colour: **Natural**.

Clutch drum assy kit 598 93 77-0-01/-02 is fully exchangeable.

4. Ball bearing 525 43 42-04 is fully exchangeable with 525 43 42-03.  
Ball bearing 525 43 42-04 is **NOT** fully exchangeable with 505 13 35-03.
5. Crankcase assy 575 38 02-22 and Shortblock 580 66 37-11 are fully exchangeable.  
New colour: **Metallic Rough**.
6. Protective cap is **NOT** fully exchangeable. **NOTE:** Only for use on new Crankcase 575 38 02-22 and Shortblock 580 66 37-11.

Introduced from

Serial number / Date	Remark
S/n 20202200049	Valid for Clutch drum assy / Worm wheels / Oil pump
S/n 20202400001	Valid for Clutch cover / Crankcase / Ball bearing / Crankshaft

<b>Page Title</b>	<b>Ref. no</b>	<b>New part no</b>	<b>Name</b>	<b>Excl. part no.</b>	<b>Remark</b>
Chain brake & clutch cover	5	501 84 61-01	Clutch cover assy	505 19 90-05	
	14	523 05 80-01	Label		<b>Remain as spare part</b>
Clutch & oil pump	3	575 26 10-07	Clutch drum assy RIM .325 7T		<b>New spare part</b>
	3	575 26 10-08	Clutch drum assy RIM 3/8 7T		<b>New spare part</b>
	6	586 20 17-01	Worm wheel .325 Small SMS		<b>New spare part</b>
	6	587 63 30-01	Worm wheel 3/8 Small SMS		<b>New spare part</b>
	7	505 19 99-08	Oil pump assy Small SMS	505 19 99-05	
	21	598 93 77-01	Clutch drum assy KIT .325 Small SMS		<b>New spare part</b>
	21	598 93 77-02	Clutch drum assy KIT 3/8 Small SMS		<b>New spare part</b>
Crankshaft	3	525 43 42-04	Ball bearing	525 43 42-03	
	7	575 54 52-17	Crankshaft assy		<b>New spare part</b>
Crankcase	5	575 38 02-22	Crankcase assy	575 38 02-16	
	14	593 80 60-01	Guide bushing	501 27 08-01	
	34	596 91 13-01	Protective cap		<b>New spare part</b>
Shortblock	1	580 66 37-11	Shortblock	580 66 37-09	<b>New page H2</b>

## 1. Clutch cover

New version.

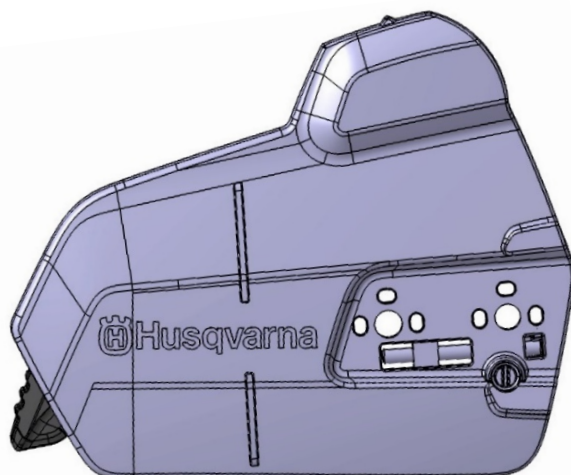

501 84 61-01

2. Clutch drum

New version.

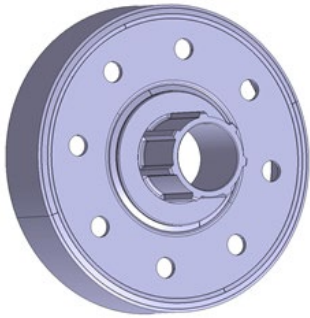

575 26 10-07/-08

Old version.

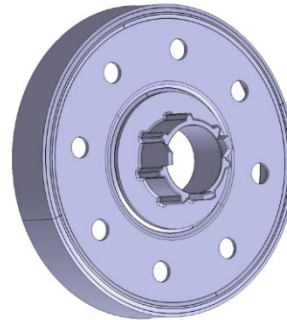

575 26 10-05/-06



3. Oil pump

New version.

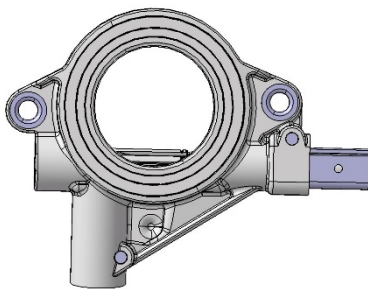

505 19 99-08

Old version.

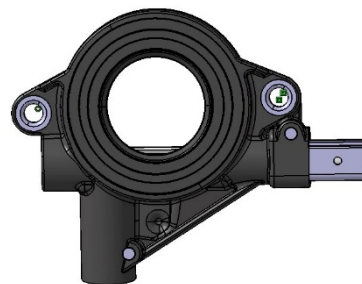

505 19 99-05



Clutch drum assy kit 598 93 77-01/-02

New

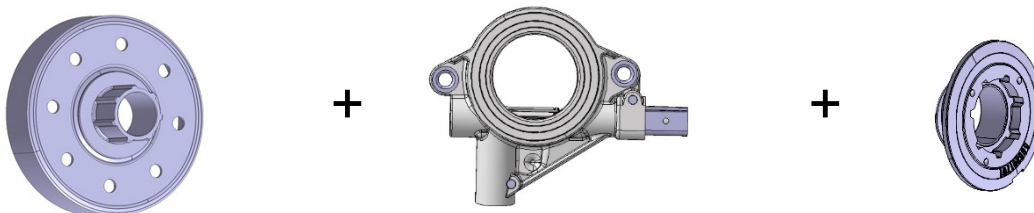

4. Crankshaft 575 54 52-17 / Crankcase 575 38 02-22 / Shortblock 580 66 37-11

New version.

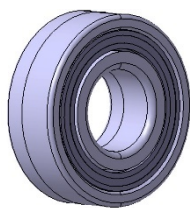

525 43 42-04

Old version.

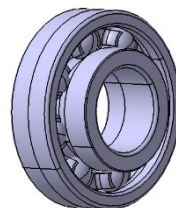

505 13 35-03



Protective cap

New



596 91 13-01