

Illustrated Parts List - IPL Update



Product Name(s)

530iPX

Description of change

Motor assy 587 69 08-01 replaced by Motor kit 546 70 36-01 including Motor (529 65 38-01), Disc spring (597 67 01-01), Washer (503 23 00-35) and Screw (503 21 53-20) (see Reference 1 in page 2).

Introduced from

Serial number / Date	Remark
up to s/n 20240900021	Page A1
From s/n 20240900022	Page A2

IPL updates

Page Title	Ref. no	New part no	Name	Excl. part no.	Remark
A1 SAW HEAD	4	See Remark	MOTOR ASSY	587 69 08-01	Old motor.
A1 SAW HEAD	30	546 70 36-01	MOTOR KIT		New motor. Will replace 587 69 08-01 after stock is finished.
A1 SAW HEAD	31	529 65 38-01	MOTOR		New motor for MOTOR KIT 546 70 36-01.
A1 SAW HEAD	23	See Remark	WASHER	577 27 15-01	Only for old motor 587 69 08-01 and CUTTING SYSTEM 529 53 71-01 without screw hole in the motor shaft (see Reference 2 in page 3).
A1 SAW HEAD	24	See Remark	CIRCLIP	735 31 12-00	Only for old motor 587 69 08-01 and CUTTING SYSTEM 529 53 71-01 without screw hole in the motor shaft (see Reference 2 in page 3).
A1 SAW HEAD	29	See Remark	CUTTING SYSTEM	529 53 71-01	New CUTTING SYSTEM includes a motor shaft with screw hole (see Reference 2 in page 3).
A1 SAW HEAD	32	597 67 01-01	DISC SPRING		See Reference 2 in page 3.
A1 SAW HEAD	33	503 23 00-35	WASHER		See Reference 2 in page 3.
A1 SAW HEAD	34	503 21 53-20	SCREW		See Reference 2 in page 3.
A2 SAW HEAD	4	529 65 38-01	MOTOR ASSY		
A2 SAW HEAD	23	597 67 01-01	DISC SPRING		
A2 SAW HEAD	24	503 23 00-35	WASHER		
A2 SAW HEAD	30	503 21 53-20	SCREW		

Illustrated Parts List - IPL Update

Reference 1

Motor assy is replaced with a new motor assy that has an internal threaded hole in the shaft.
The washer and circlip are replaced by a disc spring, washer and screw.
The screw must be tightened with 7-8 Nm and the spur sprocket must be held / fixed to enable that.

Old setup

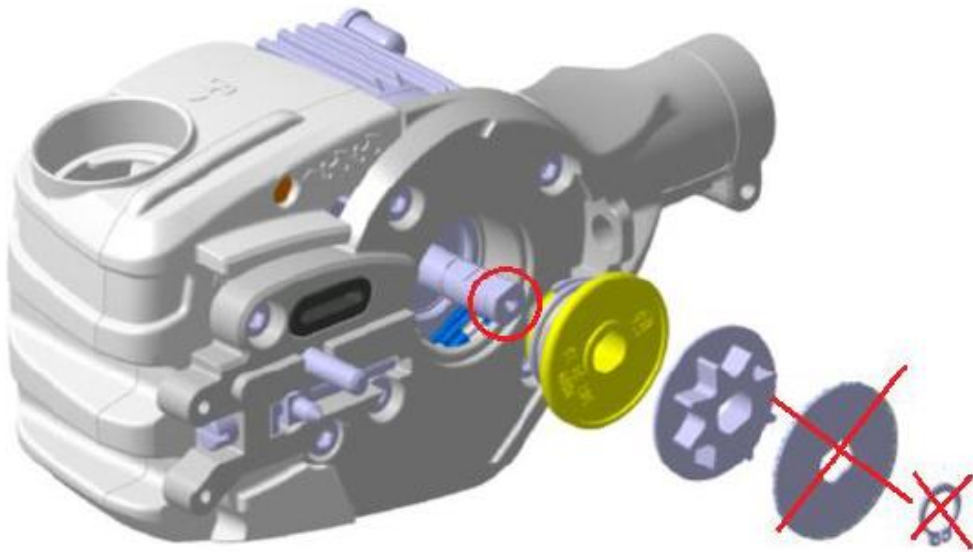

New setup

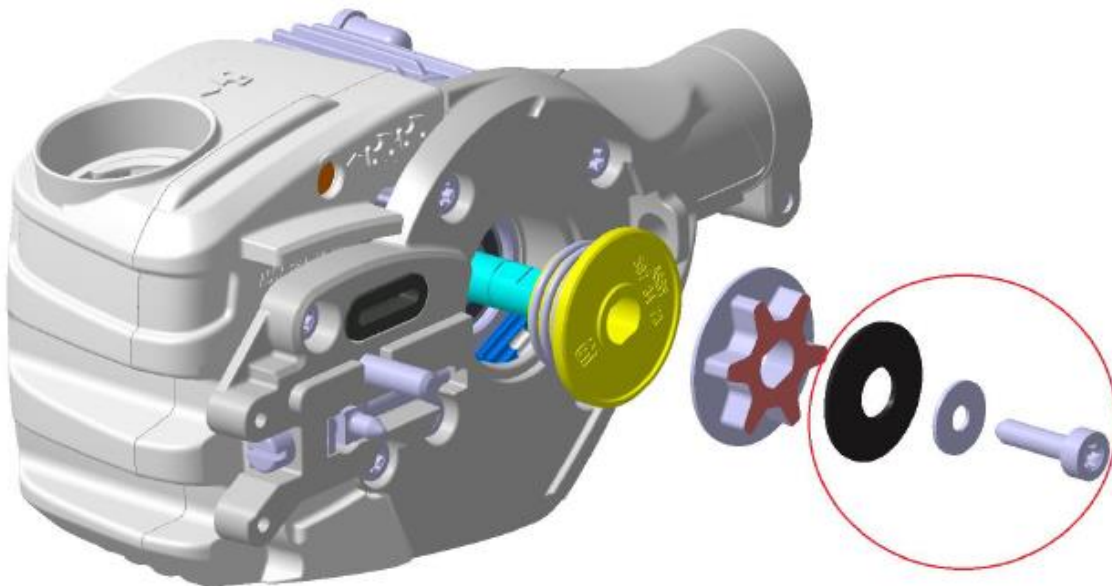

Illustrated Parts List - IPL Update



Reference 2 for CUTTING SYSTEM 529 53 71-01 IDENTIFICATION.

Old CUTTING SYSTEM 529 53 71-01 > (motor shaft without screw hole) **ONLY** compatible with CIRCLIP 735 31 12-00 and WASHER 577 27 15-01. This old cutting system includes MOTOR 587 69 08-01.

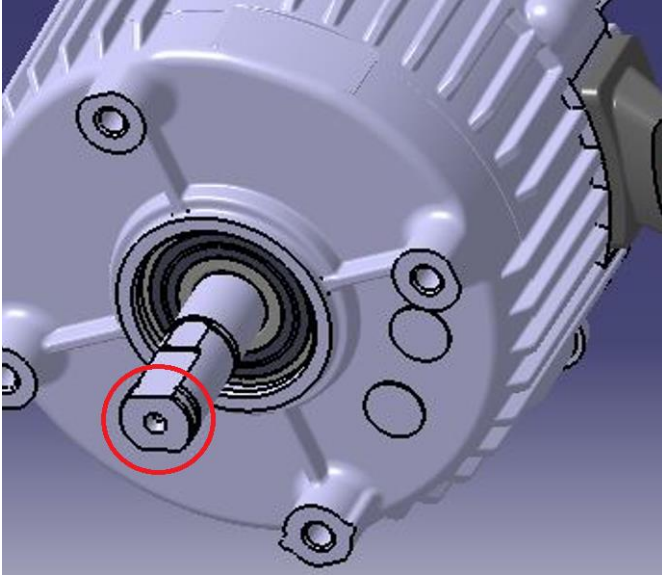

New CUTTING SYSTEM 529 53 71-01 > (motor shaft includes a screw hole, see below) **ONLY** compatible with DISC SPRING 597 67 01-01, WASHER 503 23 00-35 and SCREW 503 21 53-20. This new cutting system includes MOTOR 529 65 38-01.

