

230 ACX, 2011-01

SPARE PARTS LIST

C

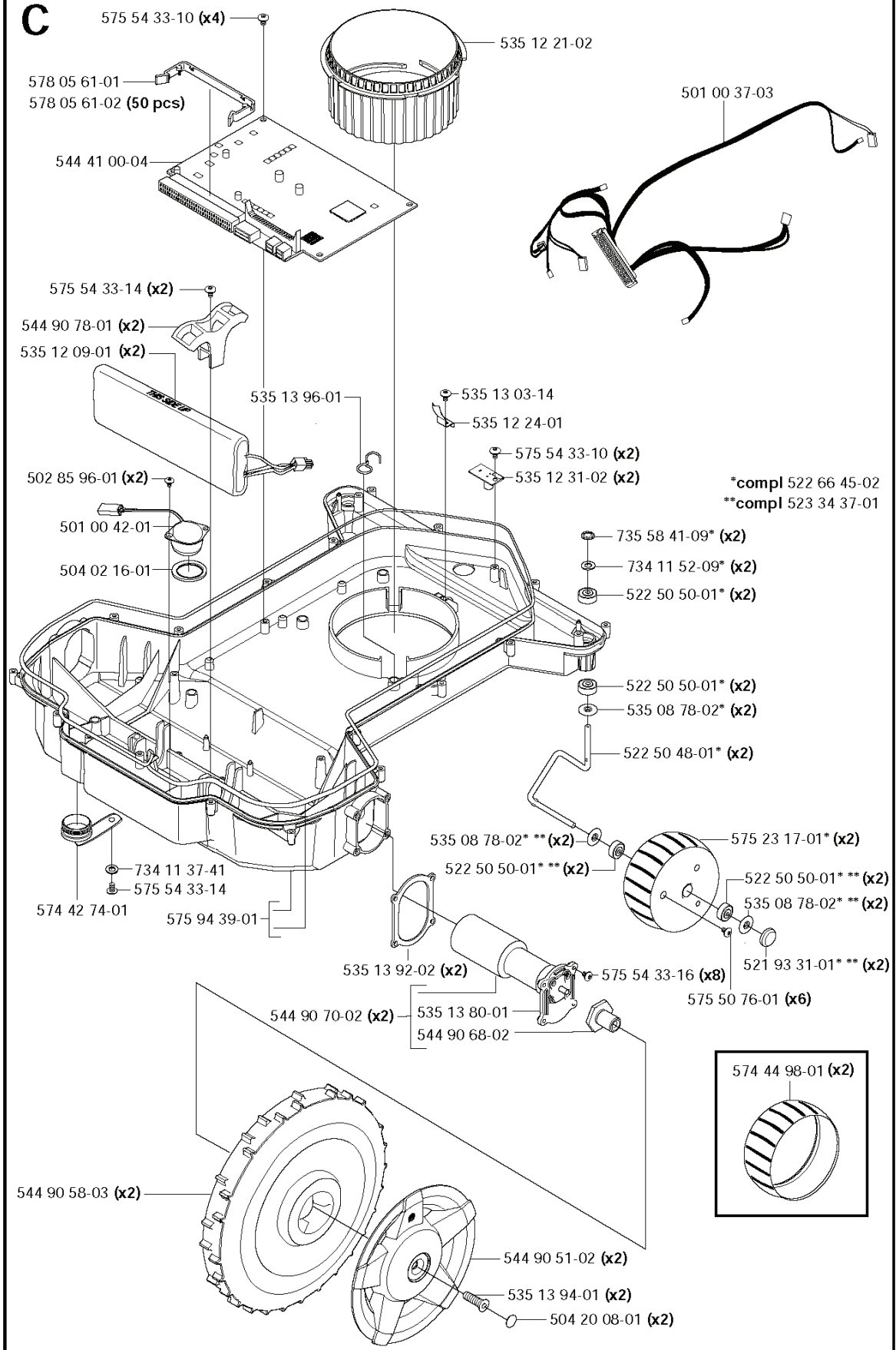

REF.	PART NO.	DESCRIPTION	REMARK	QTY.	KIT
535 12 21-02	535122102	NUT		1	
575 54 33-10	575543310	SCREW		4	
544 90 70-02	544907002	DRIVE MOTOR		2	
544 90 58-03	544905803	REAR WHEEL		2	
575 54 33-16	575543316	SCREW		8	
535 13 94-01	535139401	SCREW IHCSFM		2	
544 90 51-02	544905102	HUB CAP		2	
535 12 09-01	535120901	BATTERY		1	
522 50 50-01	522505001	BALL BEARING		2	
575 54 33-14	575543314	SCREW		2	
544 90 78-01	544907801	BRACKET		2	
501 00 37-03	501003703	WIRING ASSY		2	
544 90 68-02	544906802	HUB		1	
535 13 80-01	535138001	GABLE		1	
535 13 03-14	535130314	SCREW ITPANT		1	
535 12 24-01	535122401	LOCKING SPRING		1	
574 42 74-01	574427401	PLUG		1	
535 12 31-02	535123102	SENSOR CARD		2	
535 13 96-01	535139601	CABLE HOLDER		1	
522 50 50-01	593081101	BALL BEARING	Tube 50 pcs	1	
522 50 50-01	522505001	BALL BEARING		2	
522 50 48-01	522504801	SPINDLE		2	
535 08 78-02	535087802	WASHER		2	
535 08 78-02	535087802	WASHER		2	
522 50 50-01	522505001	BALL BEARING		2	
521 93 31-01	521933101	COVER WASHER		2	
575 23 17-01	575231701	WHEEL ASSY		2	
735 58 41-09	735584109	WASHER		2	
734 11 52-09	734115209	WASHER		2	
522 66 45-02	522664502	WHEEL KIT		1	
523 34 37-01	523343701	BEARING KIT		1	
575 54 33-14	575543314	SCREW		1	
734 11 37-41	734113741	WASHER		1	
575 50 76-01	575507601	SCREW ITPANT		6	
502 85 96-01	502859601	SCREW		2	
501 00 42-01	501004201	LOUD SPEAKER		1	
504 02 16-01	504021601	SEALING		1	
574 44 98-01	574449801	WHEEL		2	
535 13 92-02	535139202	GASKET		2	
575 94 39-01	575943901	CHASSIS		1	
504 20 08-01	504200801	COVER WASHER		2	

REF.	PART NO.	DESCRIPTION	REMARK	QTY.	KIT
544 41 00-04	544410004	PRINTED CIRCUIT ASSY		1	
578 05 61-01	578056101	CLIP		1	
578 05 61-02	578056102	CLIP		1	

B

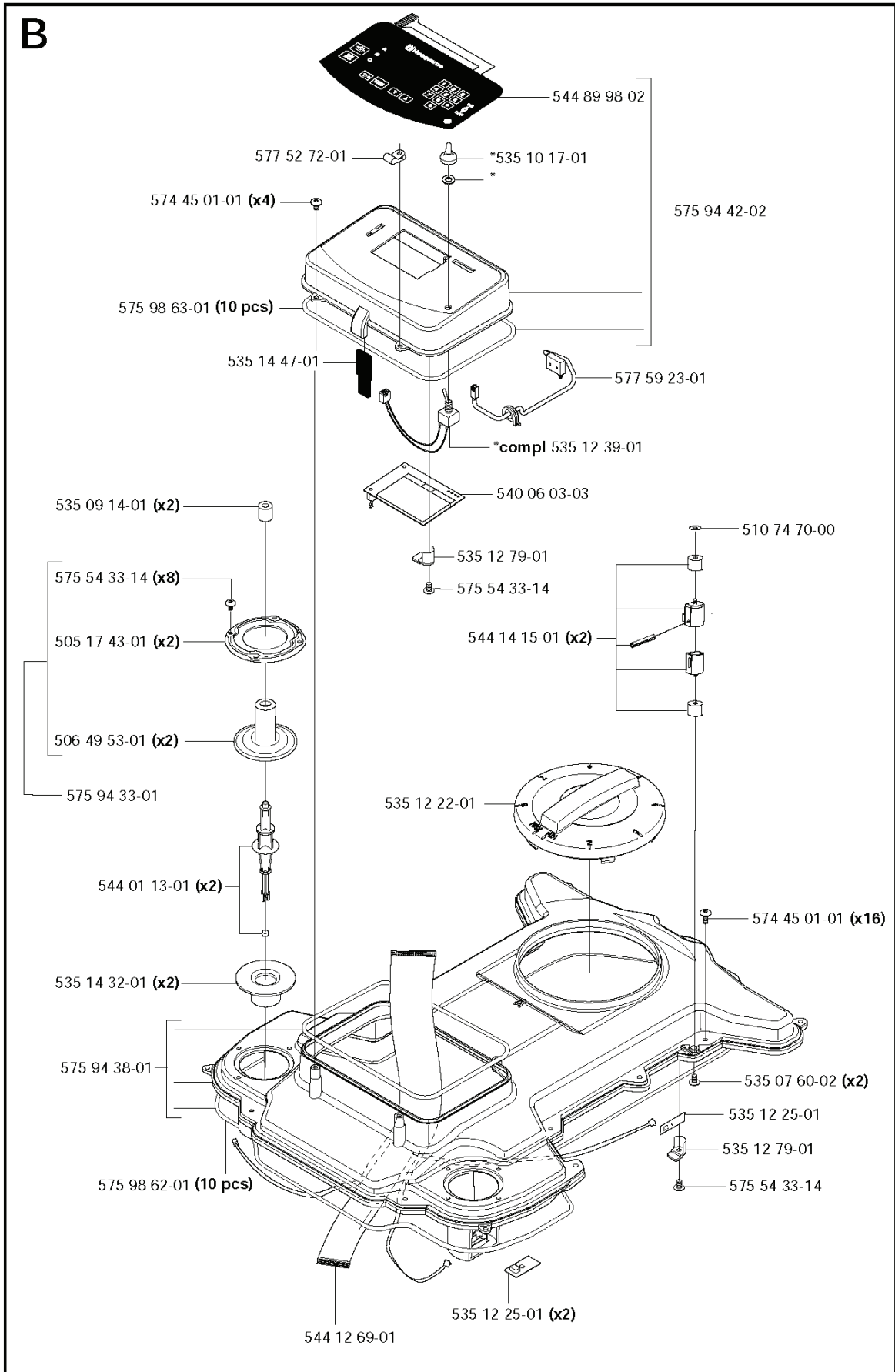

REF.	PART NO.	DESCRIPTION	REMARK	QTY.	KIT
535 12 22-01	535122201	STEERING WHEEL		1	
544 14 15-01	544141501	SENSOR		2	
535 09 14-01	535091401	DAMPER		2	
544 01 13-01	544011301	COLUMN		2	
535 14 32-01	535143201	DEFLECTION LIMITER		2	
575 54 33-14	575543314	SCREW		8	
505 17 43-01	505174301	DUST SEAL		2	
506 49 53-01	506495301	RUBBER GAITERS		2	
575 94 33-01	575943301	KIT		1	
574 45 01-01	574450101	SCREW ITPANT		16	
535 07 60-02	535076002	SCREW		2	
544 12 69-01	544126901	WIRING ASSY		1	
535 12 25-01	535122501	SENSOR CARD		2	
575 54 33-14	575543314	SCREW		1	
535 12 25-01	535122501	SENSOR CARD		1	
577 59 23-01	577592301	SWITCH KIT		1	
544 89 98-02	544899802	KEYBOARD		1	
540 06 03-03	540060303	DISPLAY		1	
575 94 42-02	575944202	DISPLAY COVER		1	
535 10 17-01	535101701	SWITCH		1	
535 12 39-01	535123901	MAIN SWITCH		1	
535 14 47-01	535144701	FILTER		1	
535 12 79-01	535127901	BRACKET		1	
575 98 63-01	575986301	SEALING STRIP		1	
575 94 38-01	575943801	CHASSIS		1	
575 98 62-01	575986202	SEALING STRIP		1	
577 52 72-01	577527201	CABLE CLAMP		1	
510 74 70-00	510747000	LOCKWASHER		1	

A

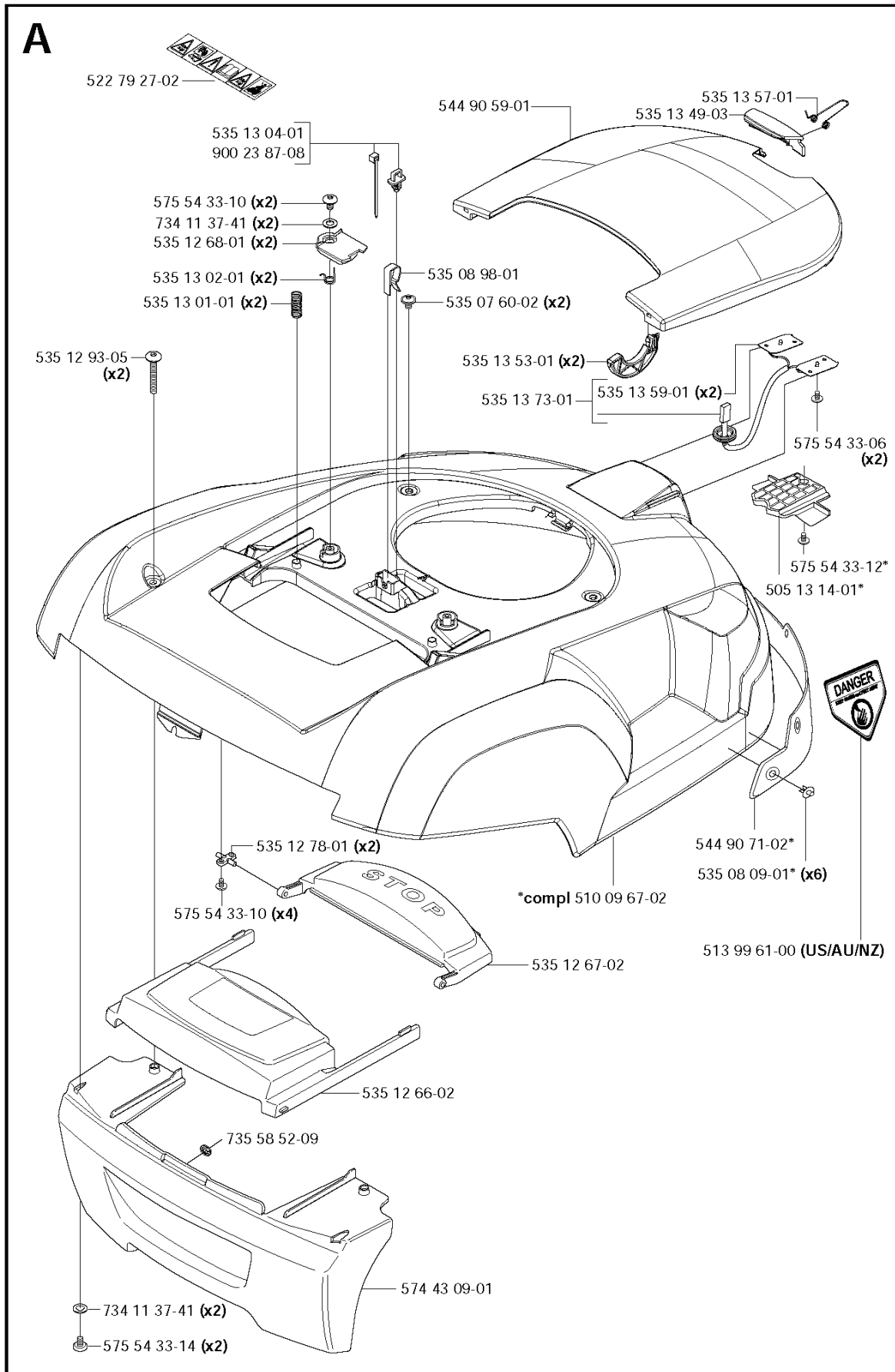

REF.	PART NO.	DESCRIPTION	REMARK	QTY.	KIT
574 43 09-01	574430901	BUMPER		1	
535 12 66-02	535126602	COVER		1	
535 12 67-02	535126702	SWITCH		1	
535 13 01-01	535130101	SPRING		2	
535 12 68-01	535126801	CLAMP		2	
535 13 02-01	535130201	TORSION SPRING		2	
535 12 78-01	535127801	SHAFT		2	
535 12 93-05	535129305	SCREW IH PANM		2	
544 90 59-01	544905901	COVER		1	
575 54 33-10	575543310	SCREW		4	
535 07 60-02	535076002	SCREW		2	
535 08 98-01	535089801	CLIP		1	
535 13 53-01	535135301	PIVOT		2	
535 13 49-03	535134903	LOCK		1	
535 13 57-01	535135701	TORSION SPRING		1	
575 54 33-06	575543306	SCREW		2	
535 13 59-01	535135901	CHARGING PLATE		2	
535 13 04-01	535130401	ANCHOR		1	
900 23 87-08	900238708	TIE WRAP		1	
522 79 27-02	522792702	LABEL		1	
535 13 73-01	535137301	WIRING		1	
734 11 37-41	734113741	WASHER		2	
575 54 33-14	575543314	SCREW		2	
544 90 71-02	544907102	BUMPER		1	
535 08 09-01	535080901	RIVET		6	
735 58 52-09	735585209	WASHER		1	
513 99 61-00	513996100	DECAL		1	
575 54 33-12	575543312	SCREW		1	
505 13 14-01	505131401	SPACER		1	
510 09 67-02	510096702	BODY		1	

H Accessories
Zubehöre
Accessoires
Acessorios
Tillbehör

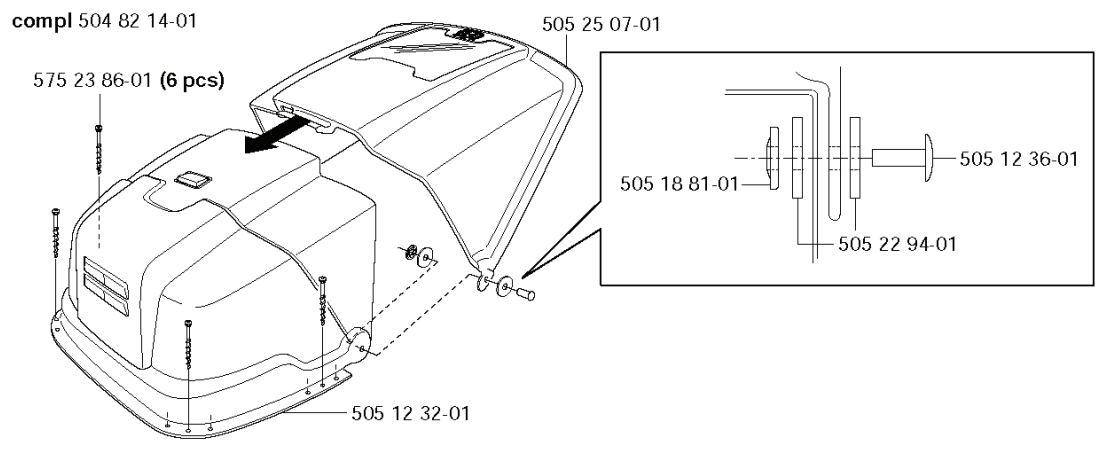
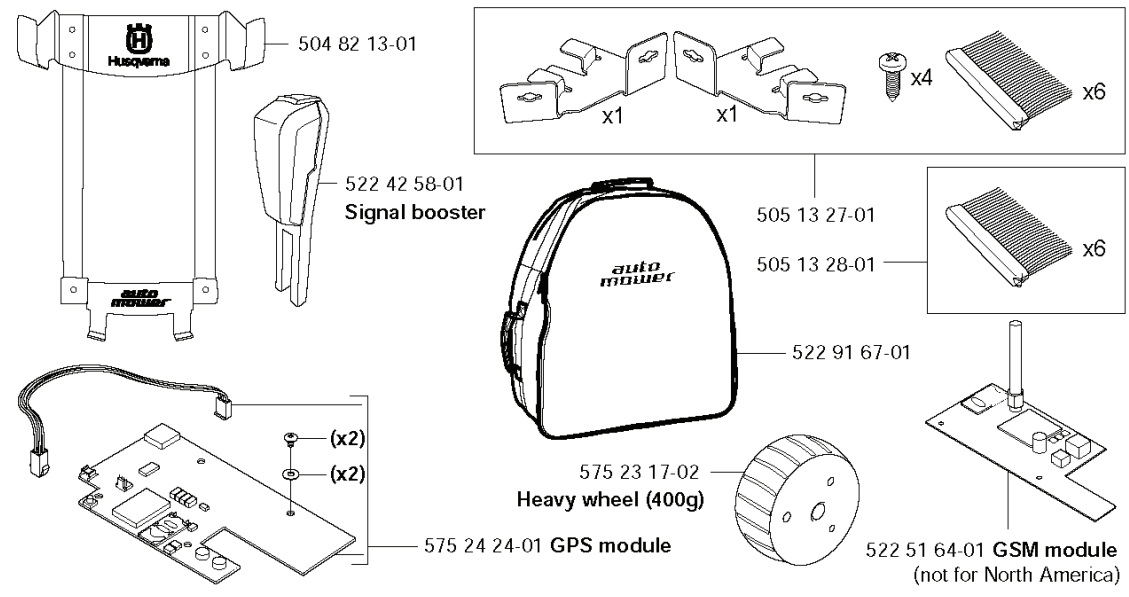
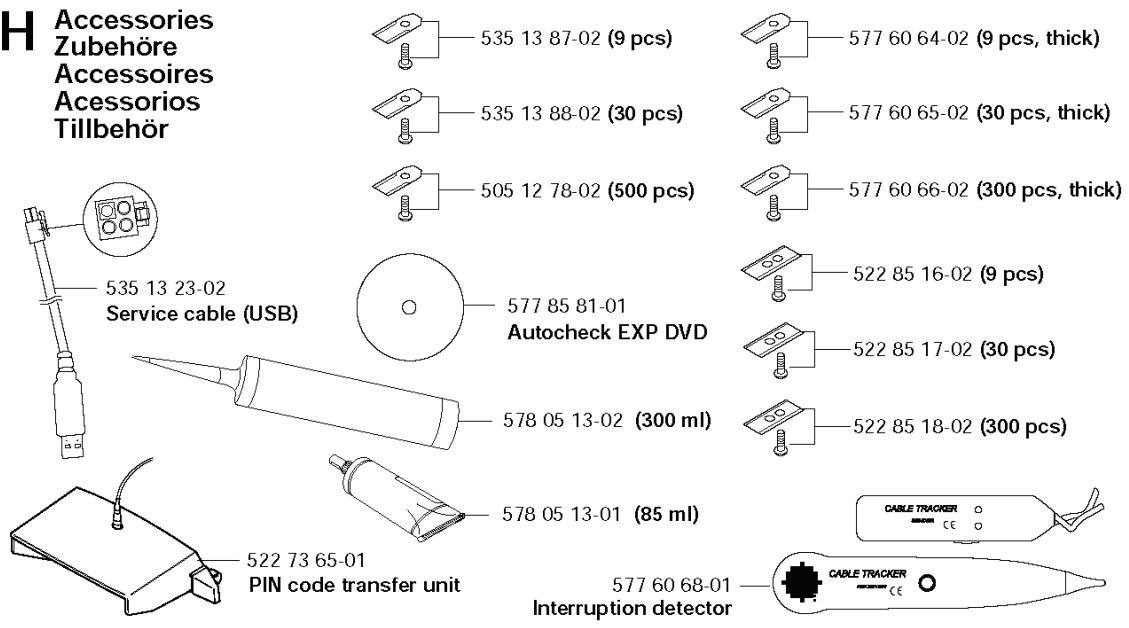

REF.	PART NO.	DESCRIPTION	REMARK	QTY.	KIT
5048213-01	504821301	WALL HANGER		1	
5224258-01	522425801	BOOSTER		1	
5051327-01	505132701	BRUSH KIT		1	
5051328-01	505132801	BRUSH		1	
5778581-01	577858101	DVD		1	
5776065-02	577606502	BLADE SET		1	
5776066-02	577606602	BLADE SET		1	
5776064-02	577606402	BLADE SET		1	
5351388-02	535138802	BLADE SET		1	
5051278-02	505127802	BLADE SET		1	
5351387-02	535138702	BLADE SET		1	
5780513-01	578051301	GREASE		1	
5780513-02	578051302	GREASE		1	
5228517-02	522851702	BLADE SET		1	
5228518-02	522851802	BLADE SET		1	
5228516-02	522851602	BLADE SET		1	
5052507-01	505250701	KIT		1	
5051232-01	505123201	HOUSING		1	
5051236-01	505123601	PEN		1	
5052294-01	505229401	WASHER		1	
5051881-01	505188101	LOCKWASHER		1	
5752386-01	575238601	SCREW KIT		1	
5048214-01	504821401	HOUSING		1	
5229167-01	522916701	BAG		1	
5752424-01	575242401	GPS MODULE		1	
5752317-02	575231702	WHEEL KIT		1	
5225164-01	522516401	GSM MODULE		1	
5227365-01	522736501	ADAPTER		1	
5776068-01	577606801	TEST EQUIPMENT		1	
5351323-02	535132302	WIRING		1	

D

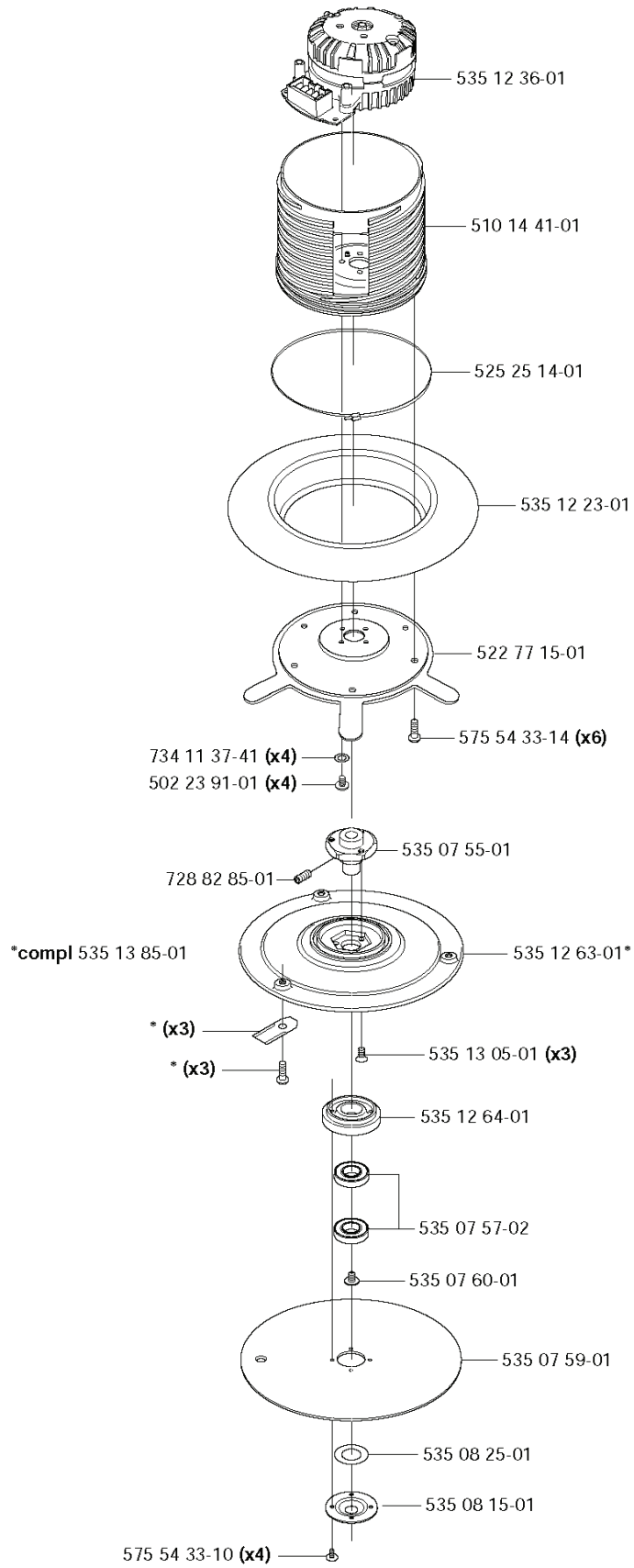

REF.	PART NO.	DESCRIPTION	REMARK	QTY.	KIT
575 54 33-10	575543310	SCREW		4	
535 08 15-01	535081501	COVER WASHER		1	
535 07 60-01	535076001	SCREW		1	
535 08 25-01	535082501	GASKET		1	
535 07 59-01	535075901	SKID PLATE		1	
535 07 57-01	593080801	BALL BEARING	Tube 50 pcs	1	
535 07 57-02	535075702	BALL BEARING		1	
535 12 64-01	535126401	HOUSING		1	
535 13 05-01	535130501	SCREW		3	
535 07 55-01	535075501	HUB		1	
728 82 85-01	728828501	SCREW IHSETM		1	
535 12 23-01	535122301	RUBBER GAITERS		1	
510 14 41-01	510144101	MOTOR BOWL		1	
535 12 36-01	535123601	MOTOR ASSY		1	
502 23 91-01	502239101	SCREW		4	
535 13 85-01	535138501	KIT		3	
535 12 63-01	535126301	CUTTING DISC		1	
734 11 37-41	734113741	WASHER		4	
525 25 14-01	525251401	TIE WRAP		1	
575 54 33-14	575543314	SCREW		6	
522 77 15-01	522771501	PLATE		1	

E compl 574 90 20-02
compl 574 90 20-05 (CH)

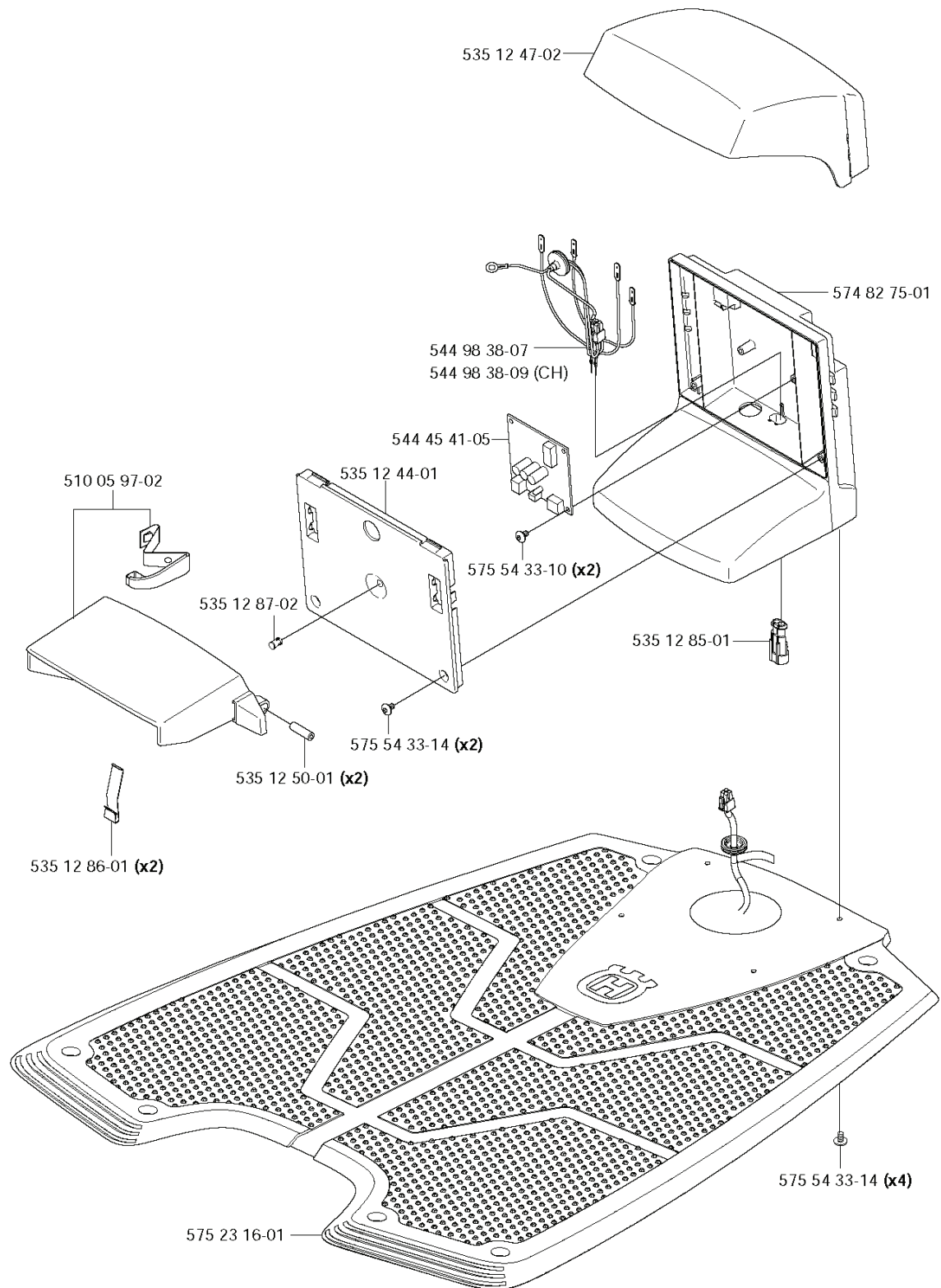

REF.	PART NO.	DESCRIPTION	REMARK	QTY.	KIT
574 82 75-01	574827501	BODY		1	
535 12 44-01	535124401	HUB CAP		1	
535 12 47-02	535124702	COVER		1	
535 12 50-01	535125001	PEN		2	
535 12 85-01	535128501	CONTACT		1	
535 12 86-01	535128601	SPRING PLATE		2	
535 12 87-02	535128702	DIODE LENS		1	
544 45 41-05	544454105	CIRCUIT BOARD ASSY		1	
575 54 33-10	575543310	SCREW		2	
574 90 20-02	574902002	CHARGING STATION		1	
574 90 20-05	574902005	CHARGING STATION		1	
575 23 16-01	575231601	CHARGING PLATE		1	
575 54 33-14	575543314	SCREW		4	
510 05 97-02	510059702	CONSOLE ASSY		1	
544 98 38-07	544983807	WIRING ASSY		1	
544 98 38-09	544983809	WIRING ASSY		1	

- F** compl 575 55 08-01 (EU)
compl 575 55 08-02 (UK)
compl 575 55 08-03 (CH)
compl 575 55 08-04 (US/CA)
compl 575 55 08-05 (AU/NZ)
compl 575 55 08-06 (MX)

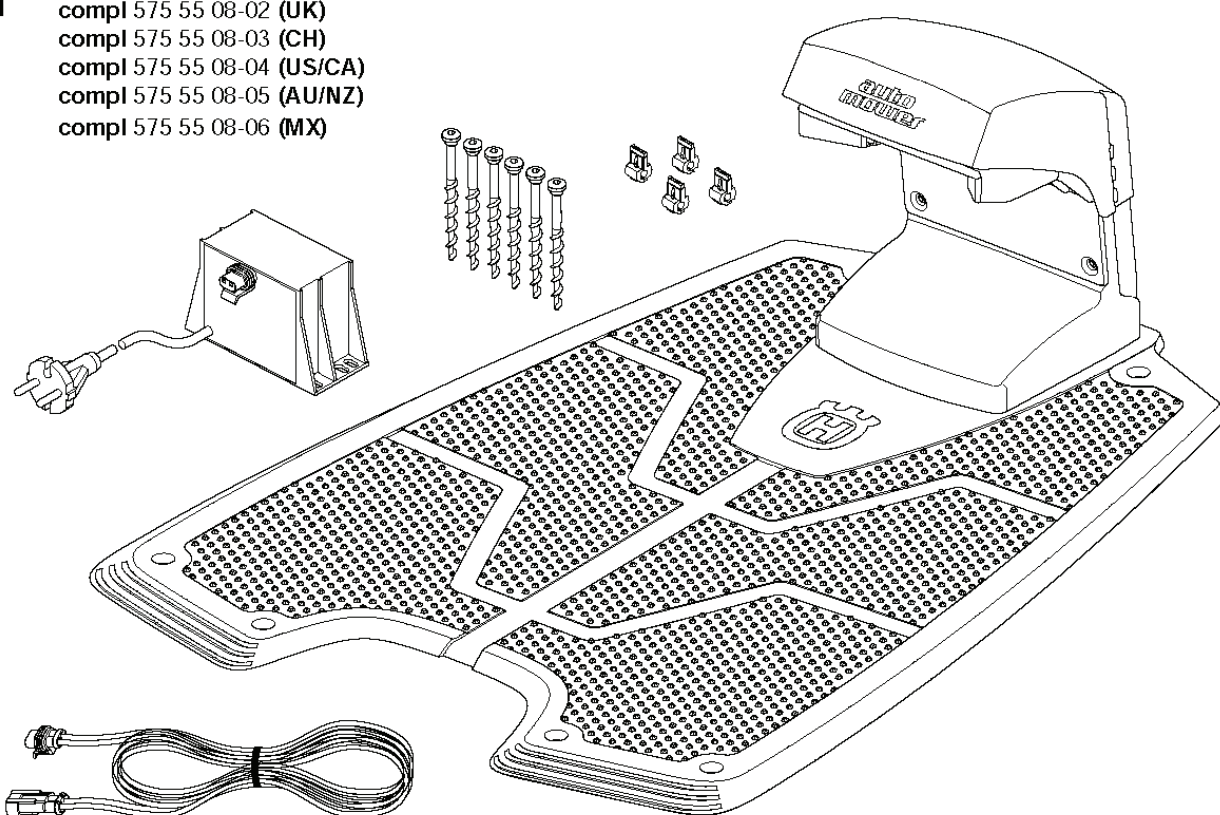

REF.	PART NO.	DESCRIPTION	REMARK	QTY.	KIT
575 55 08-01	575550801	CHARGING STATION		1	
575 55 08-02	575550802	CHARGING STATION		1	
575 55 08-03	575550803	CHARGING STATION		1	
575 55 08-04	575550804	CHARGING STATION		1	
575 55 08-05	575550805	CHARGING STATION		1	
575 55 08-06	575550806	CHARGING STATION		1	

G

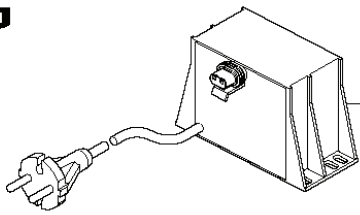

- 501 00 44-01 (EU)
- 501 00 44-02 (UK/IRL)
- 501 00 44-03 (CH)
- 501 00 44-04 (US)
- 501 00 44-05 (AU/NZ)
- 501 00 44-06 (MX)



504 04 97-01 (100 pcs)

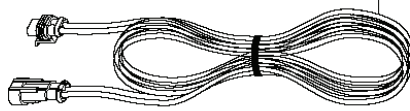

535 12 73-06 (20 m)

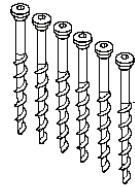

575 23 86-01 (6 pcs)



535 12 90-01



501 98 03-02 (150 m)



501 98 02-01 (1 pcs)



501 98 03-01 (250 m)



501 98 02-02 (50 pcs)

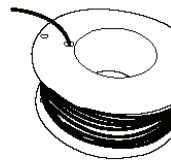

522 91 41-01 (500 m, Ø3.4 mm)



544 17 75-01



535 13 16-01

REF.	PART NO.	DESCRIPTION	REMARK	QTY.	KIT
501 00 44-01	501004401	POWER UNIT		1	
501 00 44-02	501004402	POWER UNIT		1	
501 00 44-03	501004403	POWER UNIT		1	
535 12 90-01	535129001	CONNECTOR		1	
535 13 16-01	535131601	LABEL		1	
544 17 75-01	544177501	MEASURING TAPE		1	
501 98 02-01	501980201	COUPLER		1	
504 04 97-01	504049701	STAPLE		1	
535 12 73-06	535127306	CABLE		1	
501 00 44-04	501004404	TRANSFORMER		1	
501 00 44-05	501004405	TRANSFORMER		1	
501 98 02-02	501980202	COUPLER		1	
501 98 03-01	501980301	WIRE		1	
501 98 03-02	501980302	WIRE		1	
522 91 41-01	522914101	WIRE		1	
501 00 44-06	501004406	TRANSFORMER		1	
575 23 86-01	575238601	SCREW KIT		1	