

230 ACX, 2007-05

---

# **SPARE PARTS LIST**

**H** Accessories  
 Zubehöre  
 Accessoires  
 Accesorios  
 Tillbehör



505 69 99-91

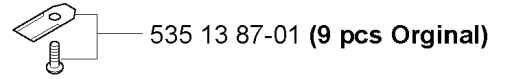

535 13 87-01 (9 pcs Original)

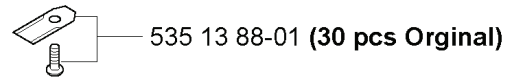

535 13 88-01 (30 pcs Original)

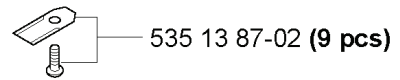

535 13 87-02 (9 pcs)

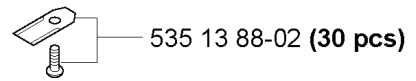

535 13 88-02 (30 pcs)

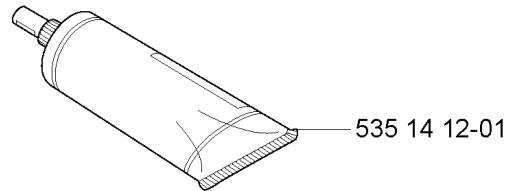

535 14 12-01

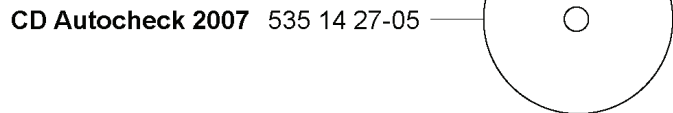

CD Autocheck 2007 535 14 27-05

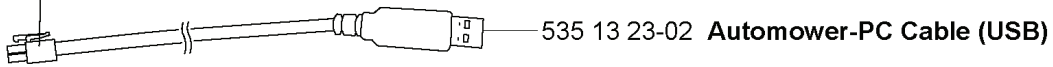
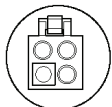

535 13 23-02 Automower-PC Cable (USB)

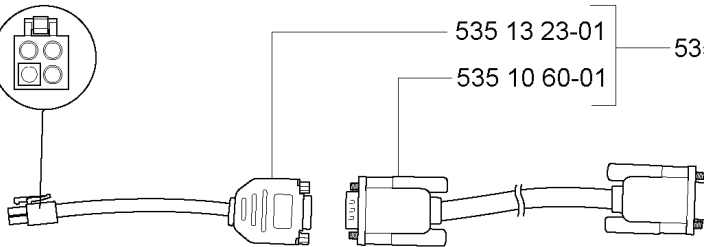
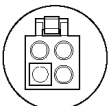

535 13 23-01

535 10 60-01

535 13 24-01 Automower-PC Cable (RS-232)

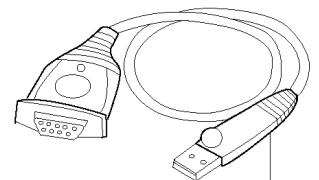

USB V-COM adapter 544 08 50-01

REF.	PART NO.	DESCRIPTION	REMARK	QTY.	KIT
505 69 99-91	505699991	BAG		1	
535 14 27-05	535142705	AUTOMOWER CD		1	
535 13 23-02	535132302	WIRING		1	
535 13 23-01	535132301	WIRING		1	
535 10 60-01	535106001	CABLE		1	
544 08 50-01	544085001	ADAPTER		1	
535 13 24-01	535132401	CABLE ASSY		1	
535 14 12-01	535141201	SEALING		1	
535 13 88-02	535138802	BLADE SET		1	
535 13 87-02	535138702	BLADE SET		1	
535 13 88-01	535138801	KIT		1	
535 13 87-01	535138701	BLADE		1	

**D**

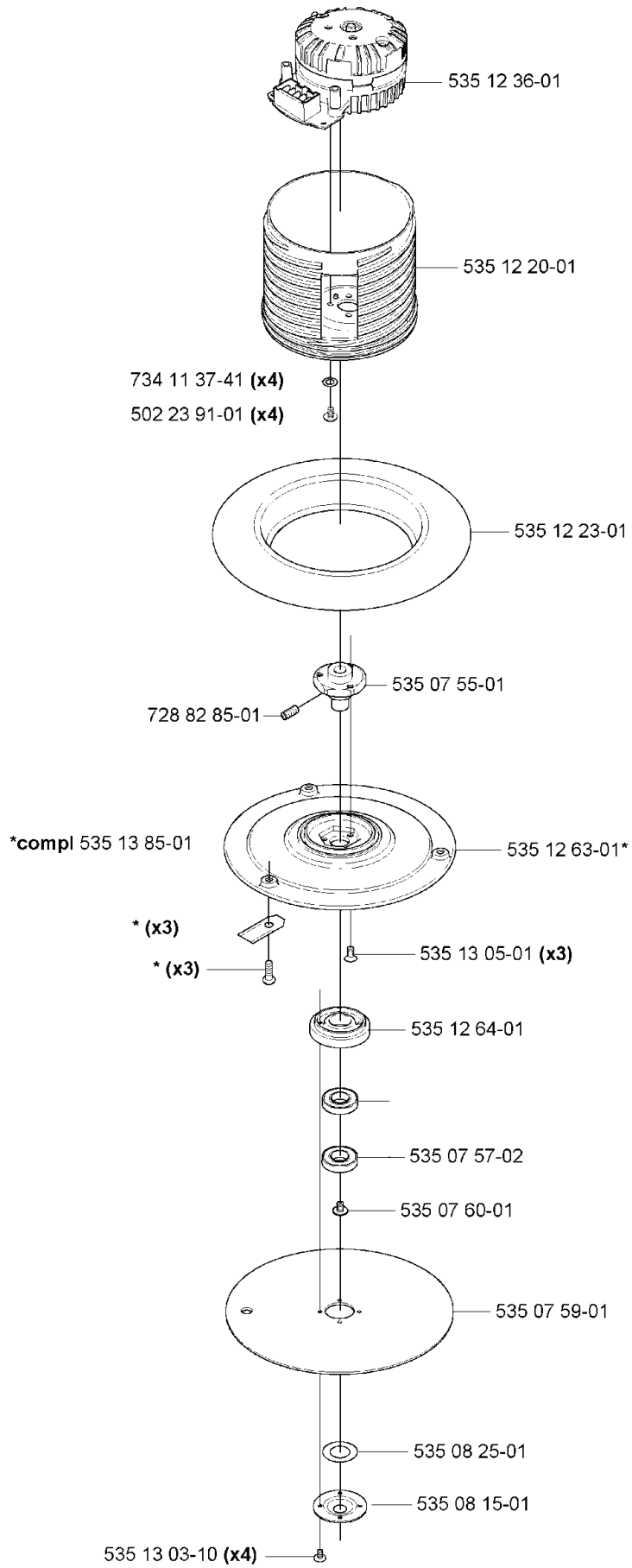

REF.	PART NO.	DESCRIPTION	REMARK	QTY.	KIT
734 11 37-41	734113741	WASHER		4	
502 23 91-01	502239101	SCREW		4	
728 82 85-01	728828501	SCREW IHSETM		1	
535 13 85-01	535138501	KIT		1	
535 13 03-10	535130310	SCREW ITXPANT		4	
535 08 15-01	535081501	COVER WASHER		1	
535 08 25-01	535082501	GASKET		1	
535 07 59-01	535075901	SKID PLATE		1	
535 07 60-01	535076001	SCREW		1	
535 07 57-02	535075702	BALL BEARING		1	
535 07 57-02	593080801	BALL BEARING	Tube 50 pcs	1	
535 12 64-01	535126401	HOUSING		1	
535 13 05-01	535130501	SCREW		3	
535 12 63-01	535126301	CUTTING DISC		1	
535 07 55-01	535075501	HUB		1	
535 12 23-01	535122301	RUBBER GAITERS		1	
535 12 20-01	535122001	MOTOR BOWL		1	
535 12 36-01	535123601	MOTOR ASSY		1	

**F** compl 544 97 31-01 (EU)  
compl 544 97 31-02 (UK)  
compl 544 97 31-03 (CH)  
compl 544 97 31-04 (US)

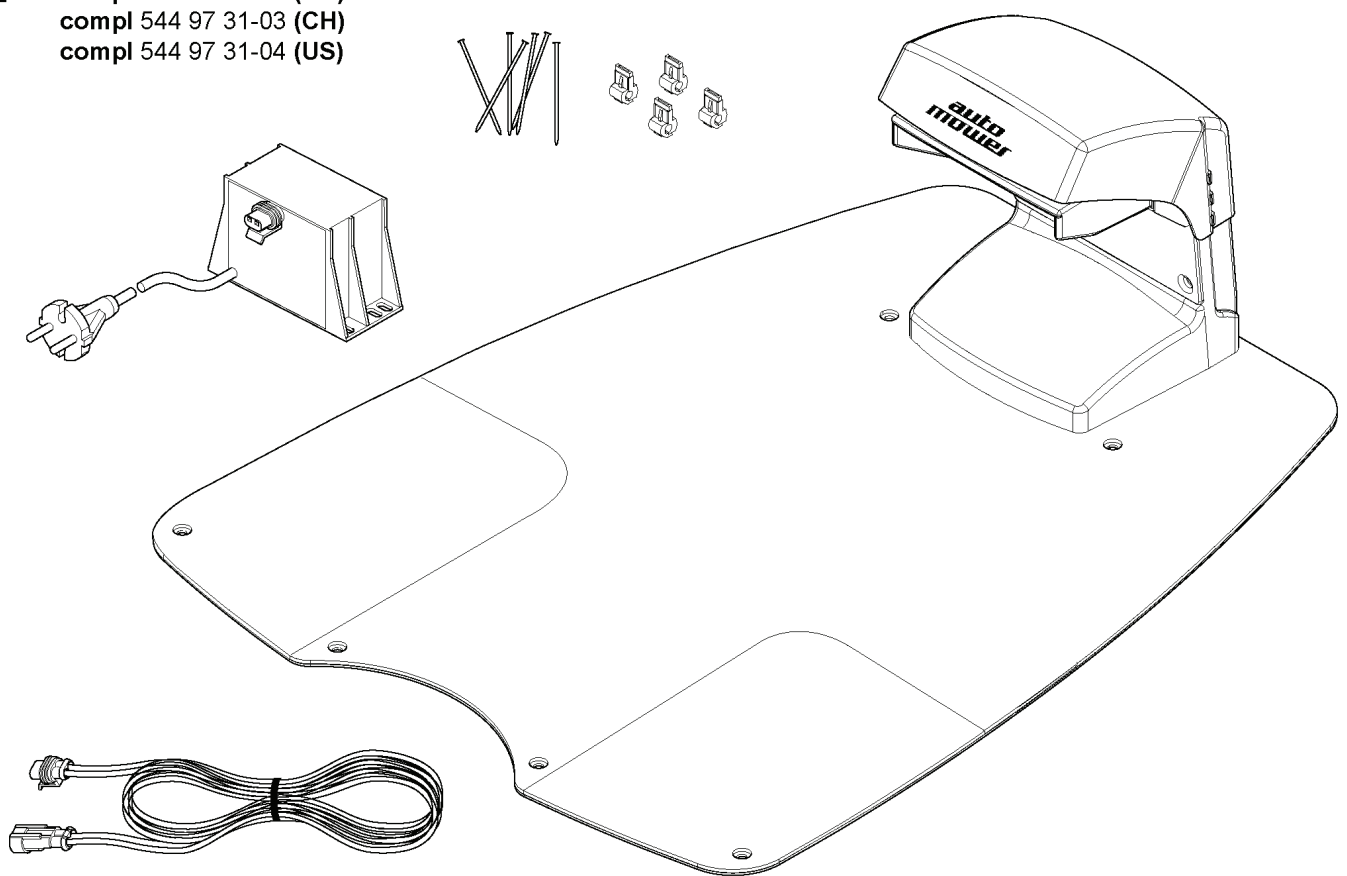

---

REF.	PART NO.	DESCRIPTION	REMARK	QTY.	KIT
544 97 31-01	544973101	CHARGING STATION		1	
544 97 31-02	544973102	CHARGING STATION		1	
544 97 31-03	544973103	CHARGING STATION		1	
544 97 31-04	544973104	CHARGING STATION		1	



**C**

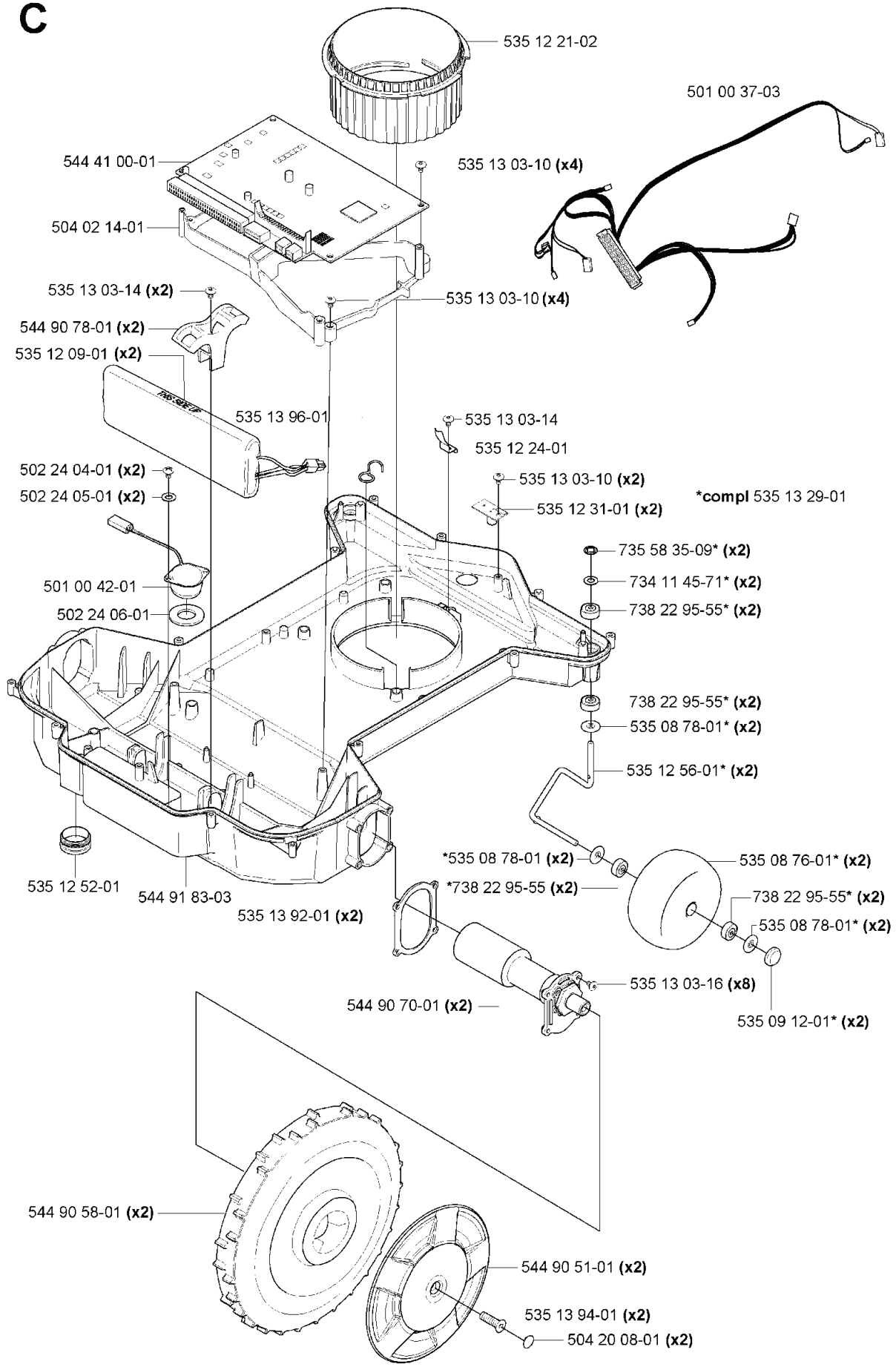

REF.	PART NO.	DESCRIPTION	REMARK	QTY.	KIT
544 41 00-01	544410001	PRINTED CIRCUIT ASSY		1	
504 02 14-01	504021401	SPACER		1	
544 90 78-01	544907801	BRACKET		2	
535 12 09-01	535120901	BATTERY		2	
535 13 96-01	535139601	CABLE HOLDER		1	
502 24 04-01	502240401	SCREW		2	
502 24 05-01	502240501	WASHER		2	
501 00 42-01	501004201	LOUD SPEAKER		1	
535 12 52-01	535125201	PLUG		1	
544 91 83-03	544918303	CHASSIS		1	
535 13 92-01	535139201	GASKET		2	
544 90 70-01	544907001	DRIVE MOTOR		2	
544 90 58-01	544905801	REAR WHEEL		2	
504 20 08-01	504200801	COVER WASHER		2	
535 13 94-01	535139401	SCREW IHCSFM		2	
544 90 51-01	544905101	HUB CAP		2	
738 22 95-55	738229555	BALL BEARING		2	
535 13 03-16	535130316	SCREW ITXPANT		8	
535 09 12-01	535091201	WASHER		2	
535 08 76-01	535087601	WHEEL		2	
535 12 56-01	535125601	SPINDLE SHAFT		2	
535 08 78-01	535087801	COVER WASHER		2	
734 11 45-71	734114571	WASHER		2	
735 58 35-09	735583509	WASHER		2	
535 13 29-01	535132901	KIT		1	
535 12 31-01	535123101	SENSOR CARD		2	
535 13 03-10	535130310	SCREW ITXPANT		2	
535 12 24-01	535122401	LOCKING SPRING		1	
535 13 03-14	535130314	SCREW ITXPANT		1	
501 00 37-03	501003703	WIRING ASSY		1	
535 12 21-02	535122102	NUT		1	

**B**

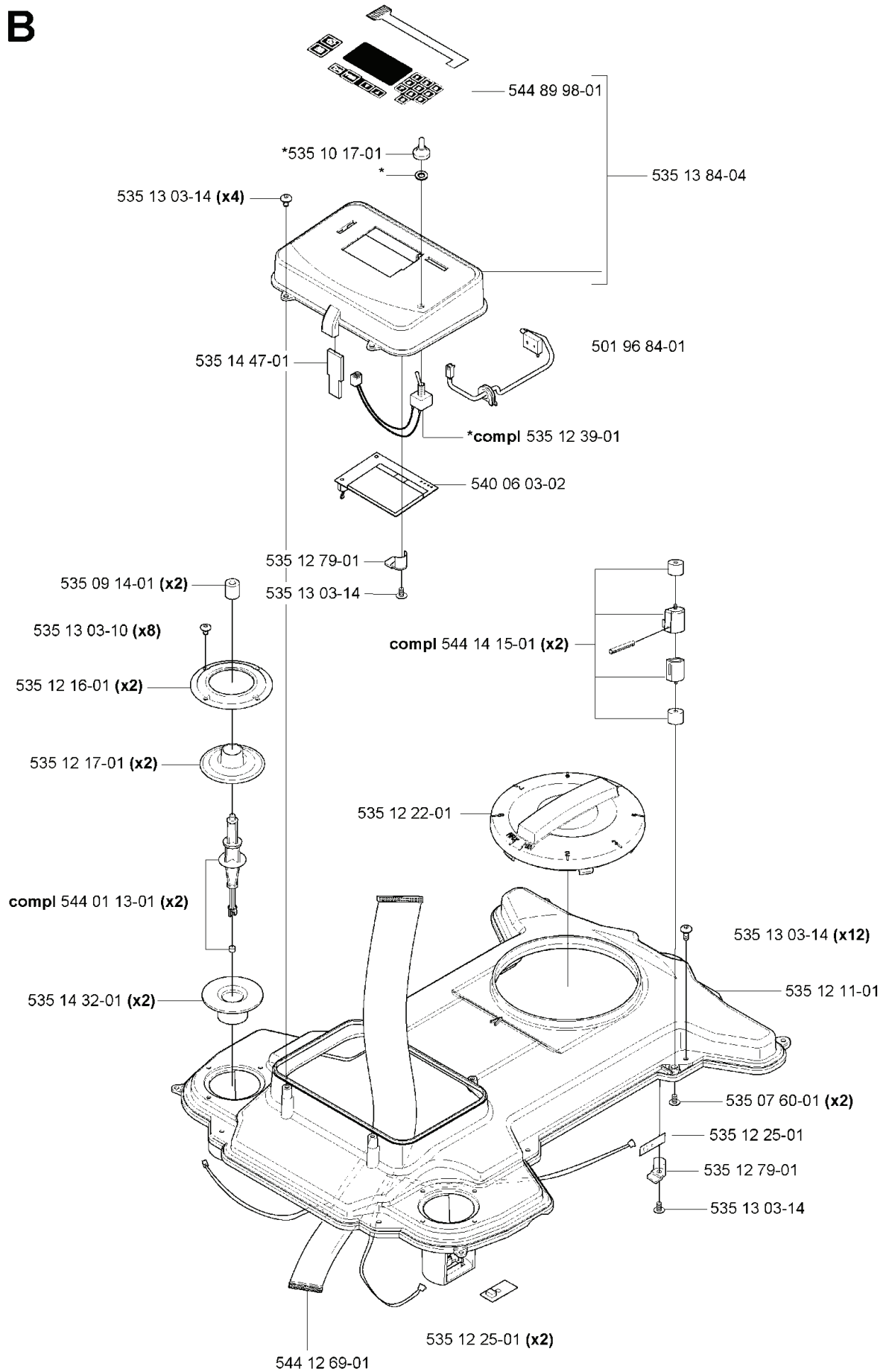

REF.	PART NO.	DESCRIPTION	REMARK	QTY.	KIT
535 10 17-01	535101701	SWITCH		1	
535 14 47-01	535144701	FILTER		1	
535 12 79-01	535127901	BRACKET		1	
535 09 14-01	535091401	DAMPER		2	
535 13 03-10	535130310	SCREW ITXPANT		8	
535 12 16-01	535121601	RING FASTENER		2	
535 12 17-01	535121701	RUBBER GAITERS		2	
544 01 13-01	544011301	COLUMN		2	
535 14 32-01	535143201	DEFLECTION LIMITER		2	
544 12 69-01	544126901	WIRING ASSY		1	
535 13 03-14	535130314	SCREW ITXPANT		1	
535 12 25-01	535122501	SENSOR CARD		1	
535 07 60-01	535076001	SCREW		2	
535 12 11-01	535121101	CHASSIS		1	
535 12 22-01	535122201	STEERING WHEEL		1	
544 14 15-01	544141501	SENSOR		2	
540 06 03-02	540060302	DISPLAY		1	
535 12 39-01	535123901	MAIN SWITCH		1	
501 96 84-01	501968401	SWITCH		1	
535 13 84-04	535138404	PANEL ASSY		1	
544 89 98-01	544899801	KEYBOARD		1	

**E** compl 504 05 37-01

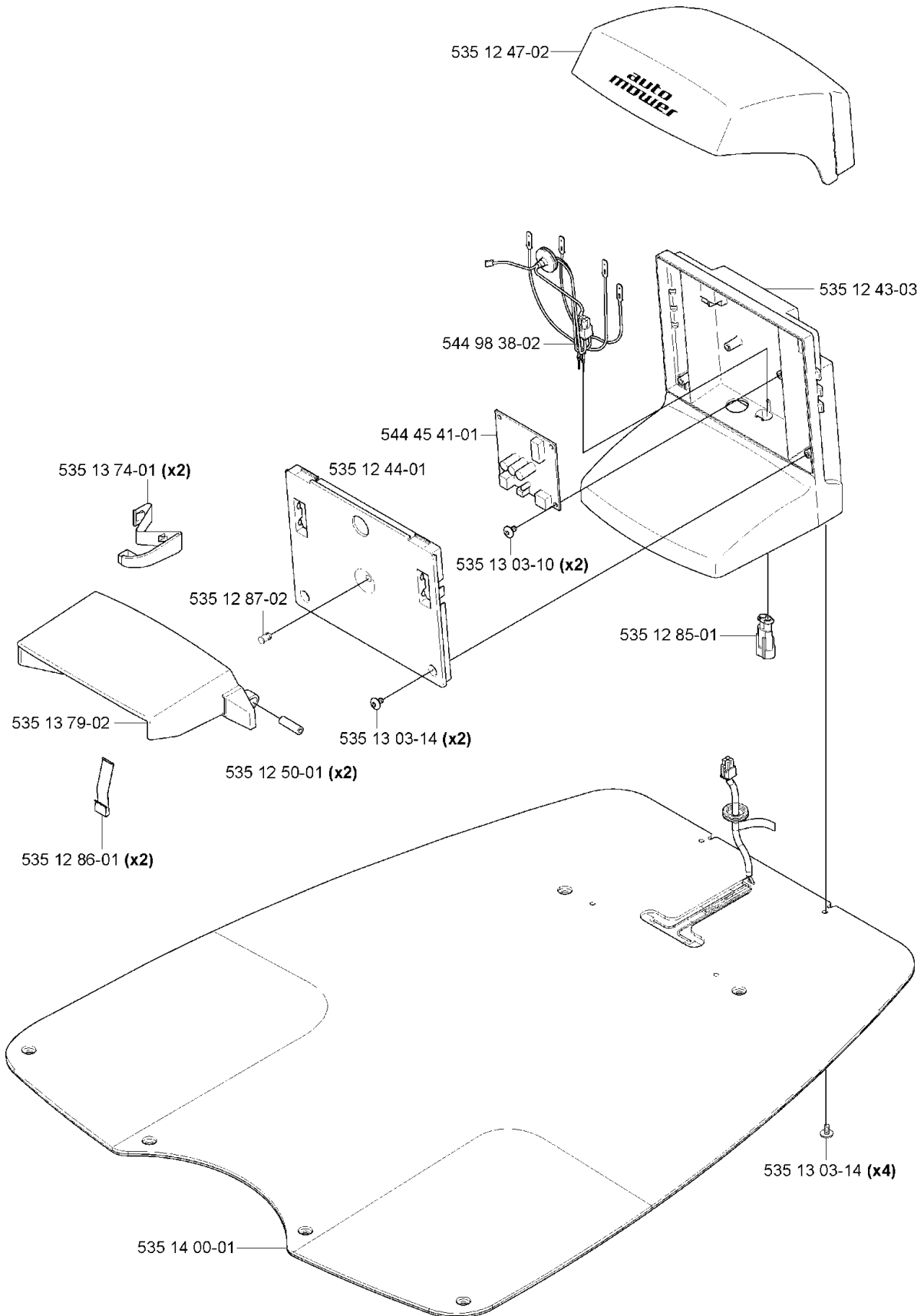

---

REF.	PART NO.	DESCRIPTION	REMARK	QTY.	KIT
5040537-01	504053701	CHARGING STATION		1	
5351247-02	535124702	COVER		1	
5449838-02	544983802	WIRING ASSY		1	
5444541-01	544454101	CIRCUIT BOARD ASSY		1	
5351244-01	535124401	HUB CAP		1	
5351374-01	535137401	CHARGING PLATE		2	
5351287-02	535128702	DIODE LENS		1	
5351250-01	535125001	PEN		2	
5351379-02	535137902	RETAINER		1	
5351286-01	535128601	SPRING PLATE		2	
5351400-01	535140001	FRAME PLATE		1	
5351303-14	535130314	SCREW ITPANT		2	
5351285-01	535128501	CONTACT		1	
5351303-10	535130310	SCREW ITPANT		2	
5351243-03	535124303	BODY		1	

**A**

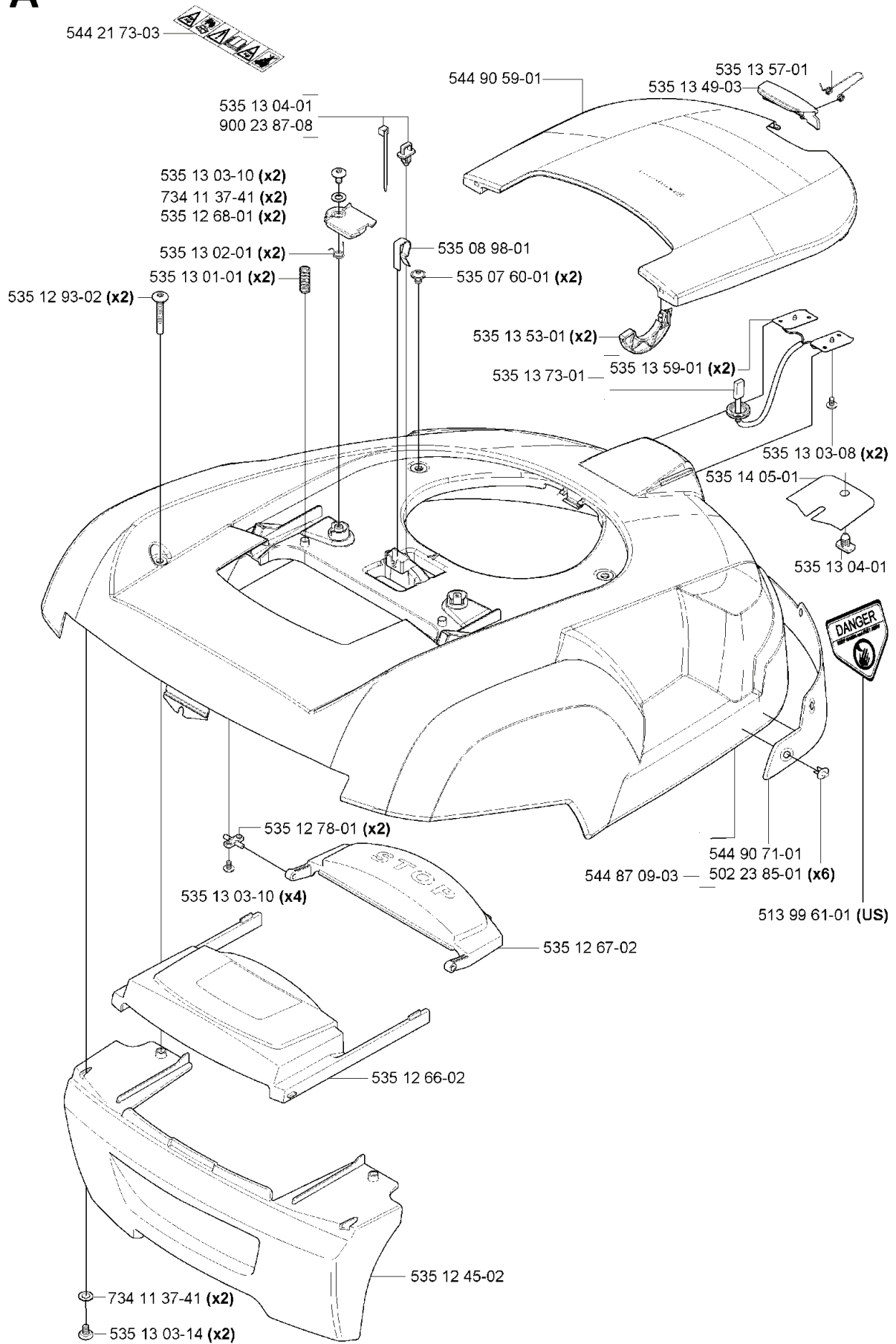

REF.	PART NO.	DESCRIPTION	REMARK	QTY.	KIT
544 21 73-03	544217303	LABEL		1	
900 23 87-08	900238708	TIE WRAP		1	
535 12 68-01	535126801	CLAMP		2	
535 13 02-01	535130201	TORSION SPRING		2	
535 13 01-01	535130101	SPRING		2	
535 12 93-02	535129302	SCREW IH PANM		2	
535 12 78-01	535127801	SHAFT		2	
535 13 03-10	535130310	SCREW ITXPANT		4	
535 12 66-02	535126602	COVER		1	
734 11 37-41	734113741	WASHER		2	
535 13 03-14	535130314	SCREW ITXPANT		2	
535 12 45-02	535124502	MAIN BODY		1	
535 12 67-02	535126702	SWITCH		1	
544 87 09-03	544870903	MAIN BODY		1	
513 99 61-01	513996101	DECAL		1	
502 23 85-01	502238501	RIVET		6	
544 90 71-01	544907101	BUMPER		1	
535 13 04-01	535130401	ANCHOR		1	
535 14 05-01	535140501	PROTECTIVE WASHER		1	
535 13 03-08	535130308	SCREW ITXPANT		2	
535 13 59-01	535135901	CHARGING PLATE		2	
535 13 73-01	535137301	WIRING		1	
535 13 53-01	535135301	PIVOT		2	
535 07 60-01	535076001	SCREW		2	
535 08 98-01	535089801	CLIP		1	
544 90 59-01	544905901	COVER		1	
535 13 49-03	535134903	LOCK		1	
535 13 57-01	535135701	TORSION SPRING		1	



I



<b>Quick Guide 220 AC &amp; 230 ACX</b>	115 03 18-XX	(US is -26)
<b>Quick Guide 210 C</b>	115 03 17-XX	(US is -26)
<b>Owners Manual 220 AC &amp; 230 ACX</b>	115 03 20-XX	
<b>Owners Manual 210 C</b>	115 03 19-XX	
<b>Technical Handbook 2007</b>	115 03 21-XX	

-01	Svenska
-06	Dansk
-11	Soumi
-21	Norsk
-26	GB English
-31	Francais
-36	Nederlands
-41	Italiano
-46	Espanol
-51	Deutsch
-59	Portugues
-61	Polski
-90	Czech
-95	US English



# G

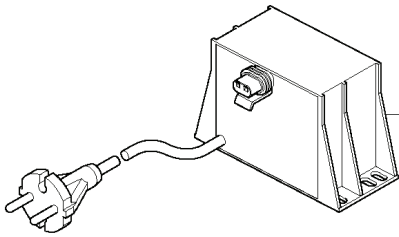

- 501 00 44-01 (EU)
- 501 00 44-02 (UK+IRL)
- 501 00 44-03 (CH)
- 501 00 44-04 (US)

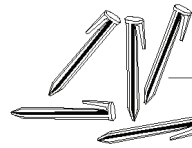

504 04 97-01 (100 pcs)

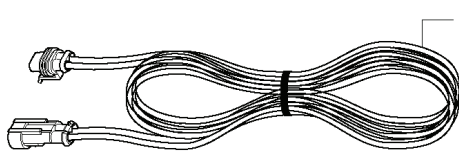

535 12 73-02 (20 m)



535 08 89-01 (6 pcs)



535 12 90-01

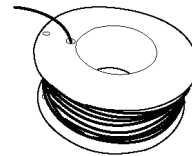

501 98 03-01 (250 m)



501 98 02-01

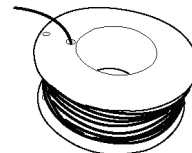

501 98 03-02 (150 m)



544 17 75-01



535 13 16-01

REF.	PART NO.	DESCRIPTION	REMARK	QTY.	KIT
501 00 44-01	501004401	POWER UNIT		1	
501 00 44-02	501004402	POWER UNIT		1	
501 00 44-03	501004403	POWER UNIT		1	
501 00 44-04	501004404	TRANSFORMER		1	
535 12 73-02	535127302	CABLE		1	
535 12 90-01	535129001	CONNECTOR		1	
501 98 02-01	501980201	COUPLER		1	
544 17 75-01	544177501	MEASURING TAPE		1	
535 13 16-01	535131601	LABEL		1	
501 98 03-02	501980302	WIRE		1	
501 98 03-01	501980301	WIRE		1	
535 08 89-01	535088901	STAPLE		1	
504 04 97-01	504049701	STAPLE		1	
	PART NO.		REMARK		KIT