

TH150 XP, HECTH150KB, 954170076, 2003

---

# **SPARE PARTS LIST**

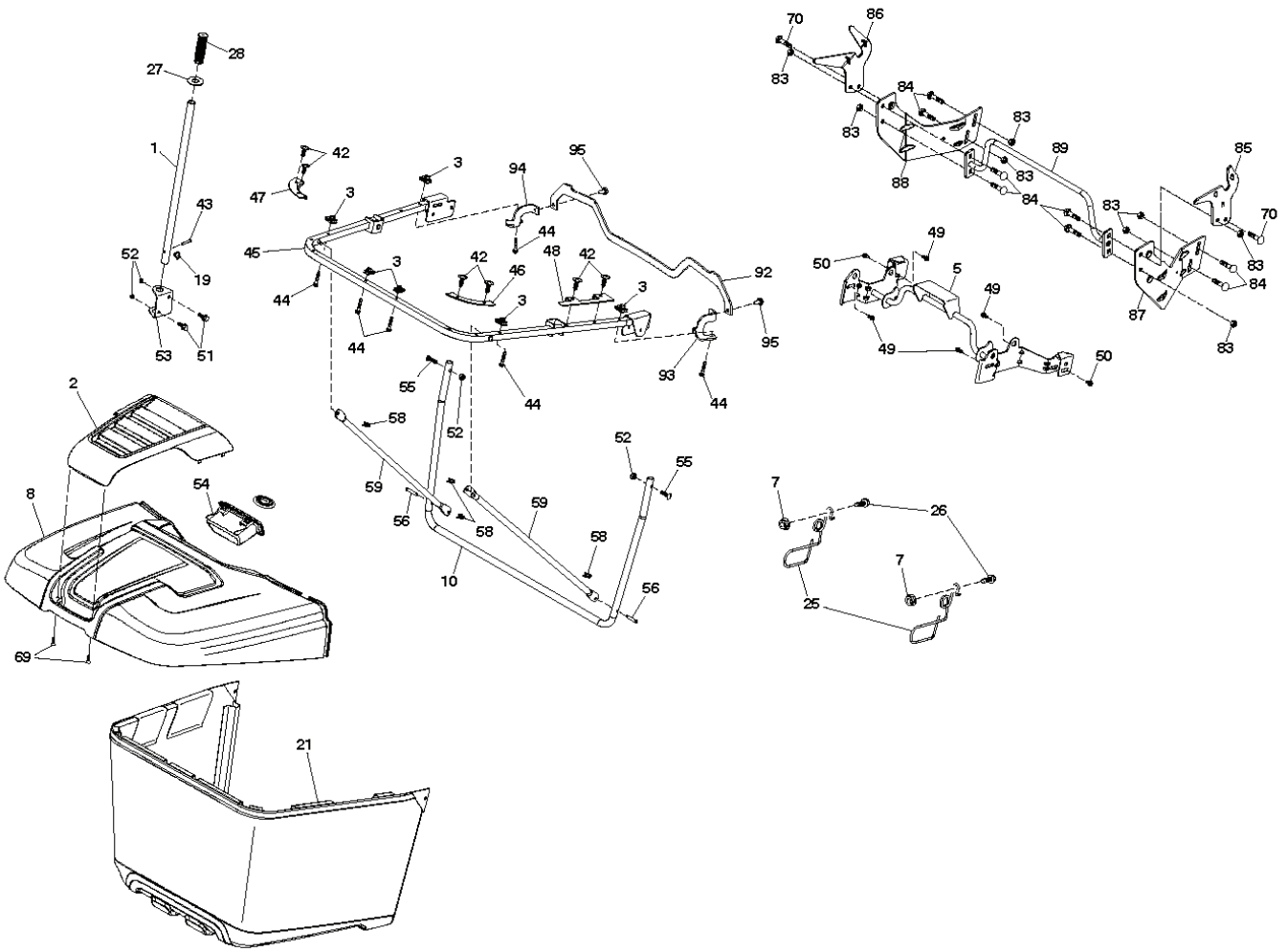

Bagger\_TexCRD-Gen2\_6

REF.	PART NO.	DESCRIPTION	REMARK	QTY.	KIT
1	532428610	TUBE		1	
2	532447572	COVER		1	
3	532174814	NUT		1	
5	532443762	FRAME		1	
7	873900400	NUT		1	
8	532447575	COVER		1	
10	532443755	FRAME		1	
19	532194208	PIN		1	
21	532445943	BAG		1	
25	532445528	LATCH		1	
26	817490412	SCREW		1	
27	532445529	GROMMET		1	
28	532165787	HANDLE		1	
42	532440428	CLIP		1	
43	532126875	RIVET		1	
44	532199687	SCREW		1	
45	532443754	FRAME		1	
46	532445541	CONNECTOR		1	
47	532444079	CONNECTOR		1	
48	532444080	BAFFLE		1	
49	532171873	BOLT		1	
50	532171877	BOLT		1	
51	872110506	BOLT		1	
52	873800500	LOCK NUT		1	
53	532444195	BRACKET		1	
54	532447218	HANDLE		1	
55	872140512	BOLT		1	
56	532420306	CLEVIS PIN		1	
58	532085179	CLIP		1	
59	532444763	TUBE		1	
69	532421801	SCREW		1	
70	817000612	SCREW		1	
83	873800600	NUT		1	
84	872110608	BOLT		1	
85	581314402	BRACKET		1	
86	581314302	BRACKET		1	
87	581314802	BRACKET		1	
88	581314702	BRACKET		1	
89	581315102	TUBE ASSY		1	
92	586052302	BRACKET		1	
93	586052402	BRACKET		1	
94	586052502	BRACKET		1	
95	817000512	SCREW		1	

# TRACTOR- -MODEL NO. CTH150XP (HECTH150KB), PRODUCT NO. 954 17 00-76 SCHEMATIC

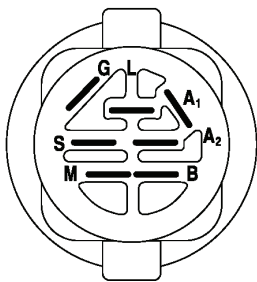
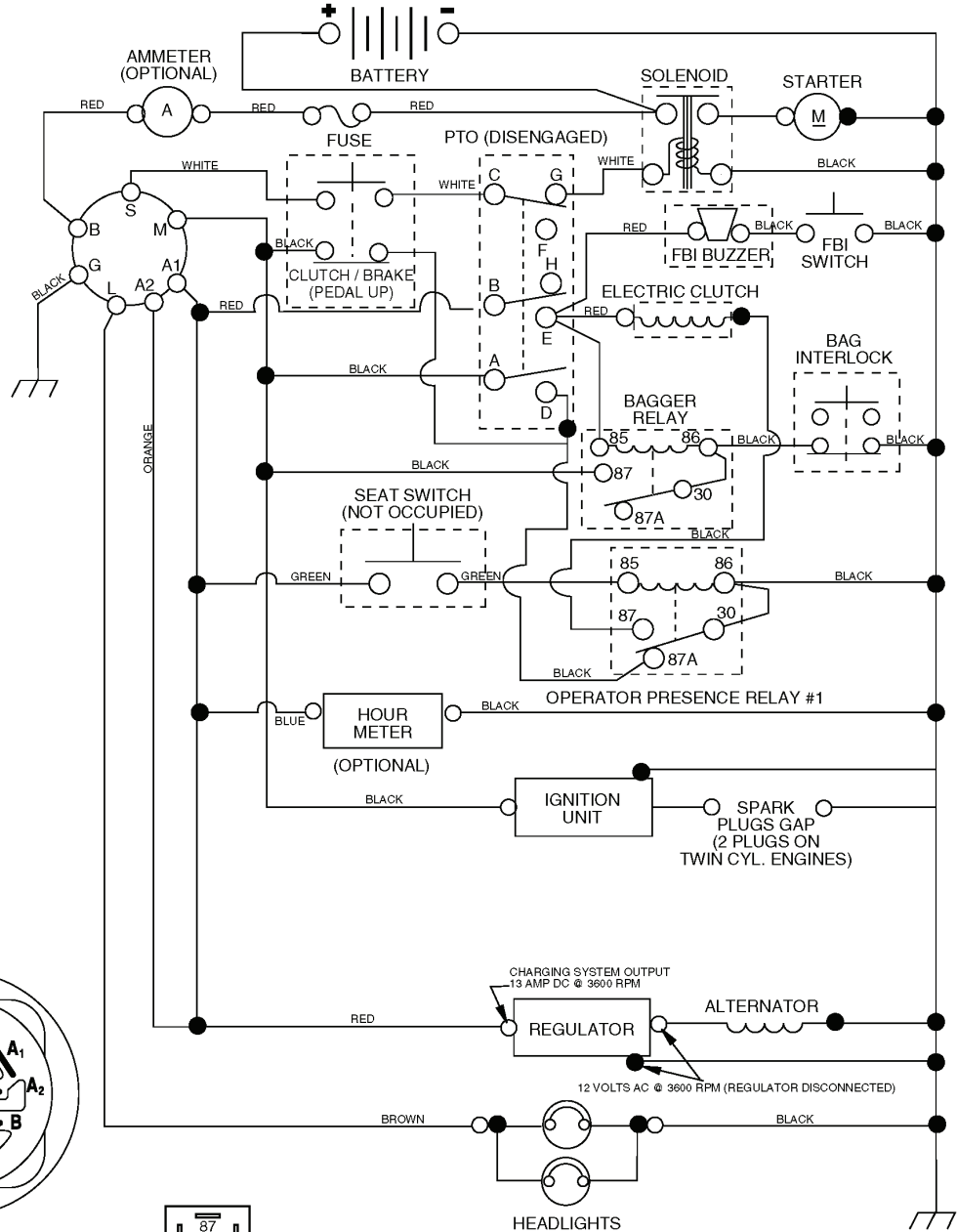

**IGNITION SWITCH**

POSITION	CIRCUIT	"MAKE"
OFF	M+G+A1	NONE
RUN/LIGHT	B+A1	A2+L
RUN	B+A1	NONE
START	B+S+A1	NONE

**WIRING INSULATED CLIPS**  
NOTE: IF WIRING INSULATED CLIPS WERE REMOVED FOR SERVICING OF UNIT, THEY SHOULD BE REPLACED TO PROPERLY SECURE YOUR WIRING.



**RELAY**

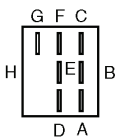

**PTO SWITCH**

POSITION	CIRCUIT
OFF	C + G, B + H
ON	C + F, B + E, A + D

● NON-REMOVABLE CONNECTIONS

○ REMOVABLE CONNECTIONS



# REPAIR PARTS

TRACTOR- -MODEL NO. CTH150XP (HECTH150KB), PRODUCT NO. 954 17 00-76  
SEAT ASSEMBLY

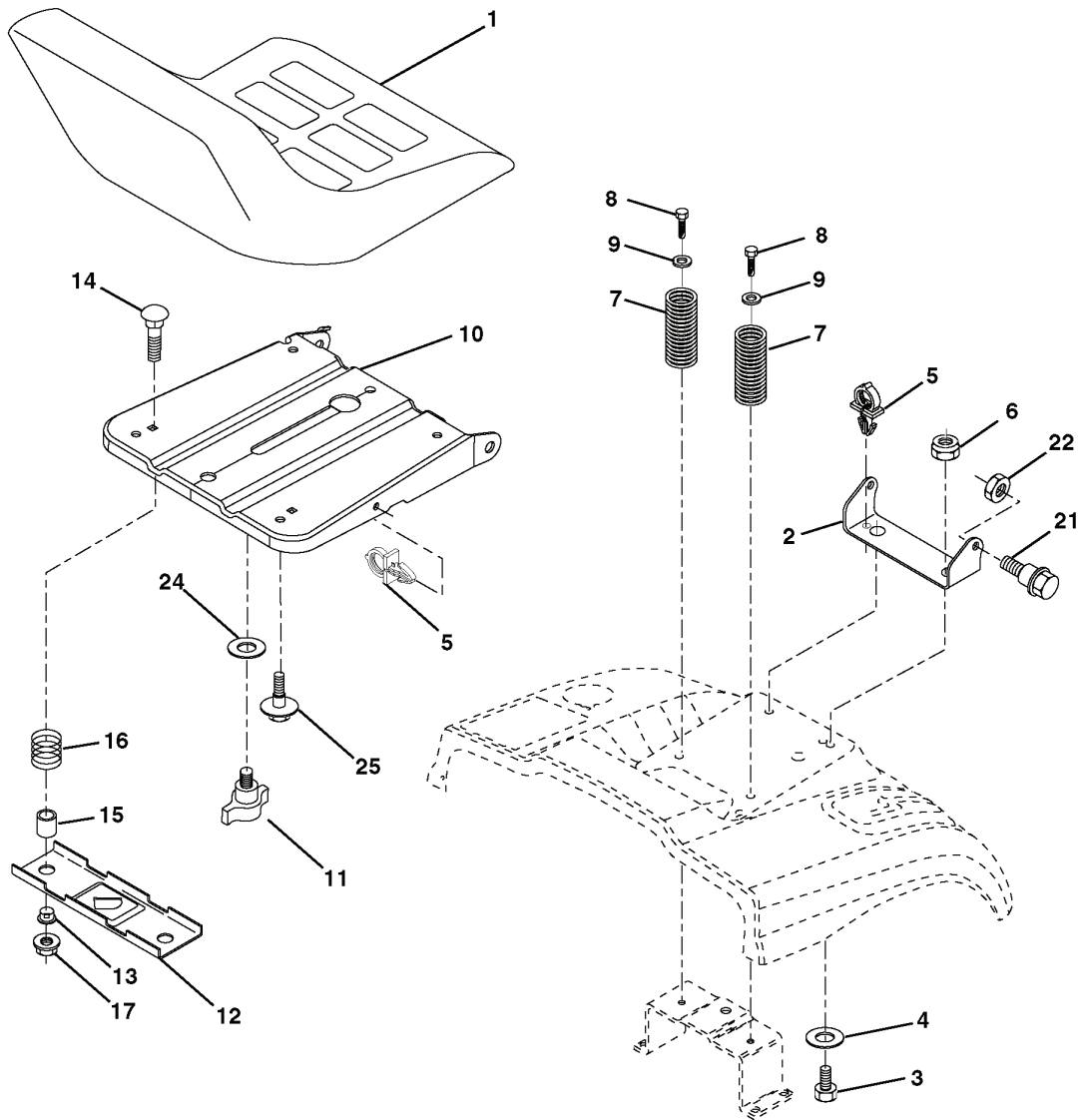

---

REF.	PART NO.	DESCRIPTION	REMARK	QTY.	KIT
1	532184995	SEAT		1	
2	532140551	BRACKET		1	
3	871110616	SCREW		1	
4	819131610	WASHER		1	
5	532145006	CLIP		1	
6	873800600	NUT		1	
7	532124181	SPRING		1	
8	817000616	SCREW		1	
9	819131614	WASHER		1	
10	532182493	BRACKET		1	
11	532166369	WING NUT		1	
12	532121246	BRACKET		1	
13	532121248	BUSHING		1	
14	872050412	BOLT		1	
15	532121249	SPACER		1	
16	532123740	SPRING		1	
17	532123976	LOCKNUT		1	
21	532171852	BOLT		1	
22	873800500	LOCK NUT		1	
24	819171912	WASHER		1	
25	532127018	BOLT		1	



# REPAIR PARTS

TRACTOR- -MODEL NO. CTH150XP (HECTH150KB), PRODUCT NO. 954 17 00-76  
STEERING ASSEMBLY

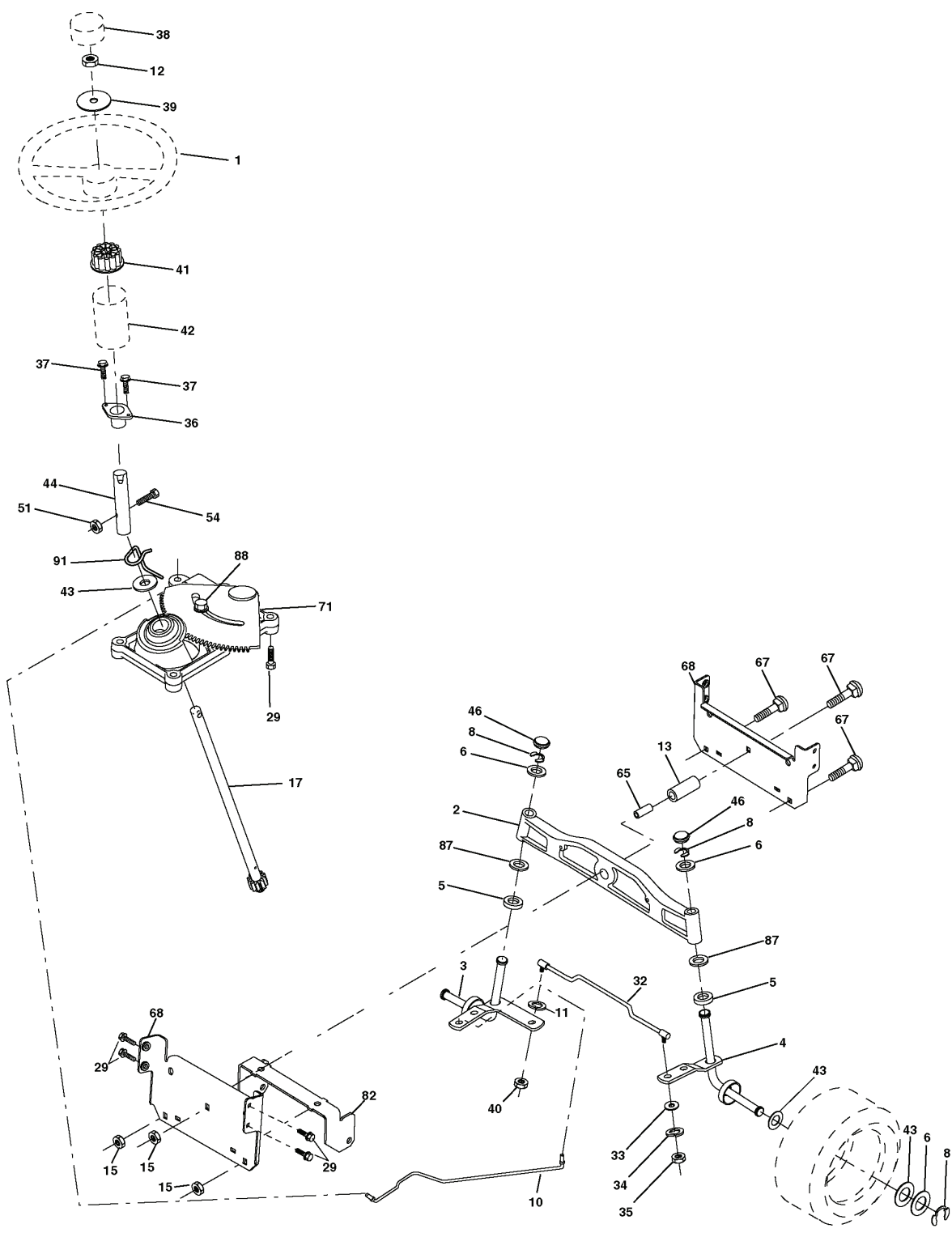

REF.	PART NO.	DESCRIPTION	REMARK	QTY.	KIT
1	532166627	STEERING WHEEL		1	
2	532172393	SHAFT		1	
3	532169840	SPINDLE		1	
4	532169839	SPINDLE		1	
5	532124931	WASHER		1	
6	532121748	WASHER		1	
8	812000029	RETAINER RING		1	
10	532175121	ROD		1	
11	810040600	WASHER		1	
12	873940800	NUT		1	
13	532136518	PIPE		1	
15	532145212	NUT		1	
17	532180641	SHAFT		1	
29	817060612	SCREW		1	
32	532171888	ROD		1	
33	819111216	WASHER		1	
34	810040500	WASHER		1	
35	873540500	NUT		1	
36	532155099	BUSHING		1	
37	532152927	SCREW		1	
38	532166626	INSERT		1	
39	819182411	WASHER		1	
40	532124701	NUT		1	
41	532159945	ADAPTER		1	
42	532169634	SLEEVE		1	
43	532121749	WASHER		1	
44	532180640	SHAFT		1	
46	532121232	HUB CAP		1	
51	873540400	NUT		1	
54	871130420	BOLT		1	
65	532160367	SPACER		1	
67	872140618	BOLT		1	
68	532169827	SHAFT		1	
71	532175146	STEERING GEAR		1	
82	532169835	BRACKET		1	
87	532173966	WASHER		1	
88	532175118	BOLT		1	
91	532175553	SPRING		1	

## REPAIR PARTS

TRACTOR- -MODEL NO. CTH150XP (HECTH150KB), PRODUCT NO. 954 17 00-76

### WHEELS & TIRES

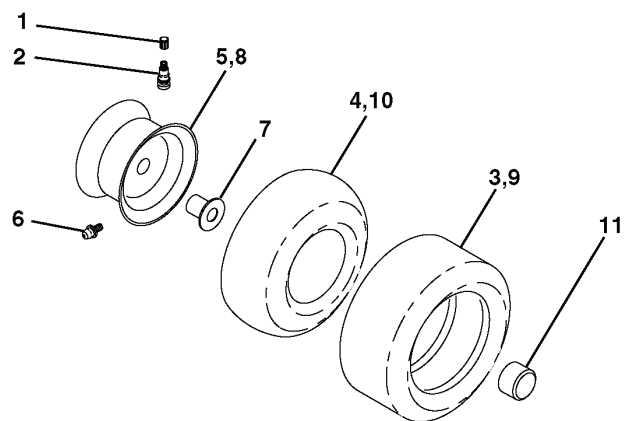

---

REF.	PART NO.	DESCRIPTION	REMARK	QTY.	KIT
1	532059192	CAP VALVE		1	
2	532065139	NIPPLE		1	
3	532106222	TIRE		1	
4	532059904	HOSE		1	
5	532138336	RIM		1	
6	532124957	FITTING		1	
7	532124959	BEARING		1	
8	532138337	RIM SPROCKET		1	
9	532138468	TIRE		1	
10	532124926	HOSE		1	
11	532175039	HUB CAP		1	
--	532144334	SEALING FOAM		1	

# REPAIR PARTS

TRACTOR- -MODEL NO. CTH150XP (HECTH150KB), PRODUCT NO. 954 17 00-76  
DRIVE

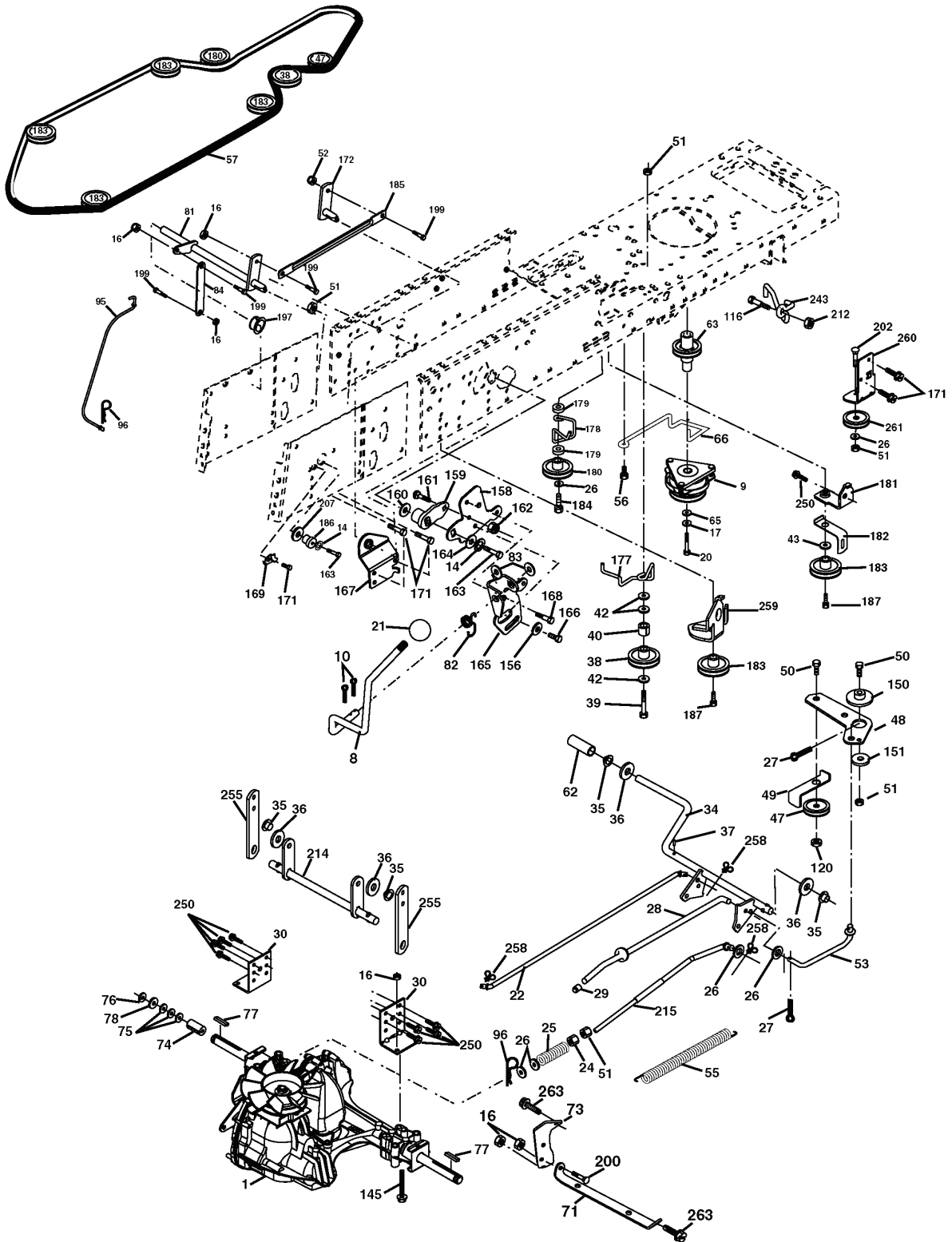

REF.	PART NO.	DESCRIPTION	REMARK	QTY.	KIT
8	532165619	ROD		1	
9	532180220	CLUTCH		1	
10	876020416	SPLIT PIN		1	
14	810040400	WASHER		1	
16	873800500	LOCK NUT		1	
17	532126197	WASHER		1	
20	871170764	BOLT		1	
21	532121274	KNOB		1	
22	532175607	ROD		1	
24	873350600	NUT		1	
25	532106888	SPRING		1	
26	819131316	WASHER		1	
27	876020412	SPLIT PIN		1	
28	532175765	SHAFT		1	
29	532071673	COVER		1	
30	532169592	BRACKET		1	
34	532175578	SHAFT		1	
35	532120183	BEARING		1	
36	819211616	WASHER		1	
37	532124963	PIN RETAINING SCREW		1	
38	532165936	PULLEY		1	
39	874760644	BOLT		1	
40	532124965	SPACER		1	
42	819131312	WASHER		1	
43	819111012	WASHER		1	
47	532127783	PULLEY		1	
48	532154407	GUIDE		1	
49	532123205	BELT GUIDE		1	
50	872110612	BOLT		1	
51	873680600	NUT		1	
52	873680500	NUT		1	
53	532105710	LINK		1	
55	532105709	SPRING		1	
56	817060620	SCREW		1	
57	532170140	BELT		1	
62	532123533	PEDAL RUBBER		1	
63	532180397	PULLEY		1	
65	810040700	WASHER		1	
66	532154778	TENSIONER		1	
71	532169183	ROD		1	
73	532169182	BRACKET		1	
74	532137057	SPACER		1	
75	532121749	WASHER		1	
76	812000001	RETAINER RING		1	
77	532123583	KEY		1	
78	532121748	WASHER		1	
81	532170006	SHAFT		1	
82	532165711	SPRING		1	
83	819171216	WASHER		1	
84	532170007	LINK		1	
95	532170015	LINK		1	
96	532124788	RETAINER RING		1	
116	872140608	BOLT		1	
120	873900600	NUT		1	
145	874490544	SCREW		1	
150	532165850	BUSHING		1	
151	819133210	WASHER		1	
156	532166002	WASHER		1	
158	532165589	BRACKET		1	
159	532183900	LEVER		1	
160	819292016	WASHER		1	
161	872140406	BOLT		1	
162	873680400	NUT		1	
163	874780416	BOLT		1	
164	819091010	WASHER		1	
165	532165623	BRACKET		1	
166	532166880	SCREW		1	
167	532165588	BRACKET		1	
168	532165492	BOLT		1	
169	532165580	RETAINER		1	
171	817490608	SCREW		1	
172	532170271	LINK		1	
177	532165932	HOLDER		1	
178	532165933	HOLDER		1	
179	532120958	WASHER		1	
180	532165630	PULLEY		1	
181	532180211	BRACKET		1	
182	532182682	BELT GUIDE		1	

---

REF.	PART NO.	DESCRIPTION	REMARK	QTY.	KIT
183	532186007	PULLEY		1	
184	817490644	SCREW		1	
185	532170008	LINK		1	
186	532165614	HUB		1	
187	817580520	BOLT		1	
197	532169613	SLEEVE		1	
199	532169612	SCREW		1	
200	872140508	BOLT		1	
202	872110614	BOLT		1	
207	532169845	WASHER		1	
212	532145212	NUT		1	
214	532175609	LEVER		1	
215	532175652	ROD		1	
243	532178289	BRACKET		1	
250	817060612	SCREW		1	
255	532175608	SHAFT		1	
258	532178062	CLIP		1	
259	532180212	BRACKET		1	
260	532181781	BRACKET		1	
261	532131494	PULLEY		1	
263	817000612	SCREW		1	

# REPAIR PARTS

TRACTOR- -MODEL NO. CTH150XP (HECTH150KB), PRODUCT NO. 954 17 00-76  
ELECTRICAL

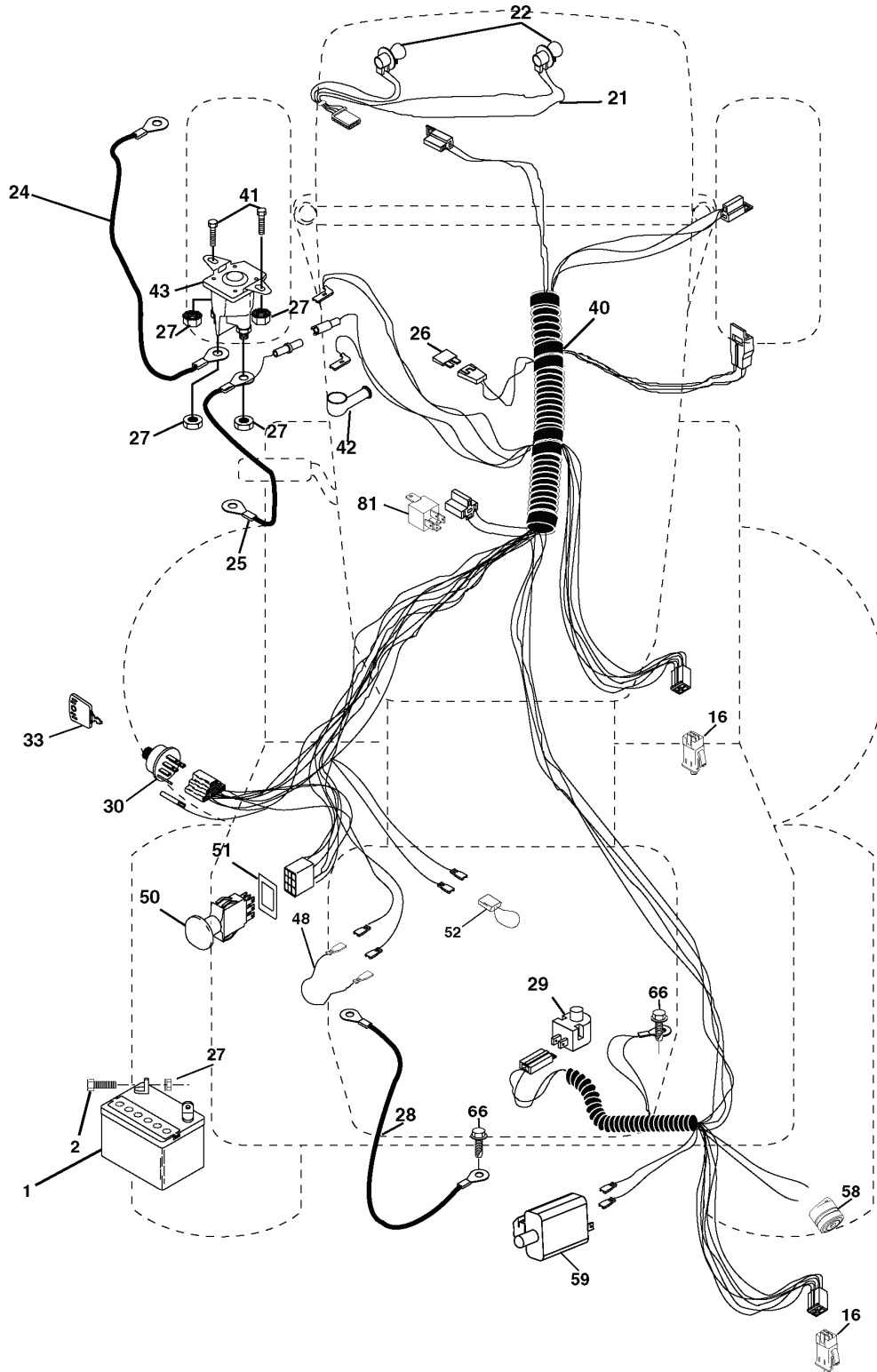



REF.	PART NO.	DESCRIPTION	REMARK	QTY.	KIT
1	532144927	BATTERY		1	
2	874760412	BOLT		1	
16	532176138	MICRO SWITCH		1	
21	532175688	HARNESS		1	
22	532004152	BULB		1	
24	532124780	CABLE		1	
25	532165987	CABLE		1	
26	532175158	FUSE		1	
27	873510400	NUT		1	
28	532127725	CABLE		1	
29	532160784	SWITCH		1	
30	532175566	SWITCH		1	
33	532140401	KEY		1	
40	532179727	HARNESS		1	
41	871110408	BOLT		1	
42	532131563	COVER		1	
43	532178861	SOLENOID		1	
48	532140844	ADAPTER		1	
50	532174651	SWITCH		1	
51	532140405	FRAME		1	
52	532141940	WIRE		1	
58	532169419	BUZZER		1	
59	532180379	SWITCH FBI		1	
66	817490608	SCREW		1	
81	532109748	RELAY		1	

# REPAIR PARTS

TRACTOR- -MODEL NO. CTH150XP (HECTH150KB), PRODUCT NO. 954 17 00-76  
ENGINE

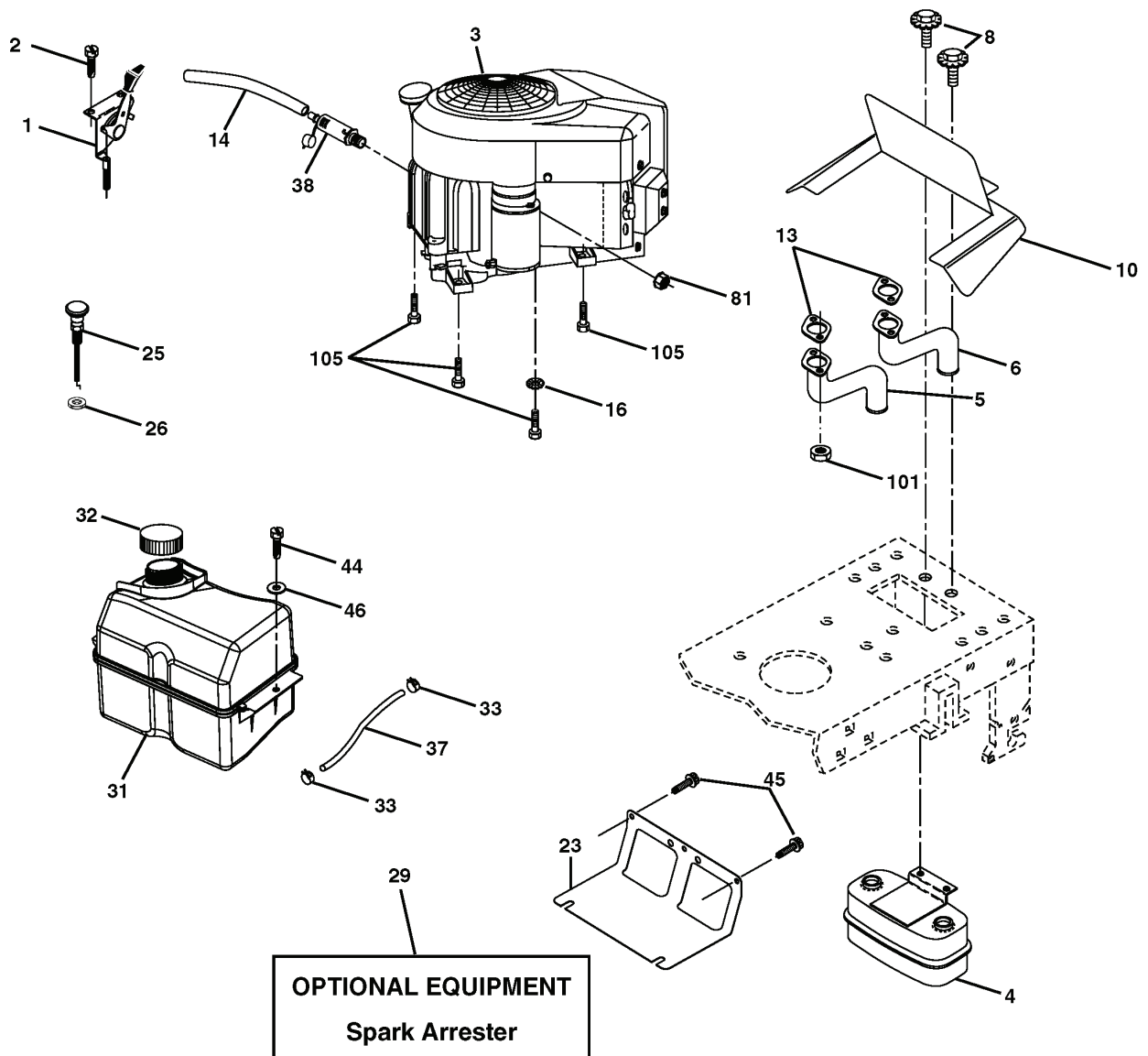

---

REF.	PART NO.	DESCRIPTION	REMARK	QTY.	KIT
1	532170803	CONTROL THROT FLAG		1	
2	817720408	SCREW		1	
4	532149723	MUFFLER		1	
5	532181444	TUBE		1	
6	532181442	TUBE		1	
8	532171877	BOLT		1	
10	532146629	HEAT SHIELD		1	
14	532148456	TUBE		1	
16	811050600	WASHER		1	
23	532169837	HEAT SHIELD		1	
25	532132782	CHOKE CONTROL		1	
26	873920600	NUT		1	
29	532137180	SPARK ARRESTER KIT		1	
31	532185534	TANK UNIT		1	
32	532140527	FUEL CAP		1	
33	532123487	HOSE CLAMP		1	
37	532137040	HOSE		1	
40	532124028	BUSHING		1	
44	817670412	SCREW		1	
45	817000612	SCREW		1	
46	819091416	WASHER		1	
81	873510400	NUT		1	
101	532163305	NUT FLANGE M8-1.25 NON-		1	
105	817120616	SCREW		1	

# REPAIR PARTS

TRACTOR- -MODEL NO. CTH150XP (HECTH150KB), PRODUCT NO. 954 17 00-76  
MOWER

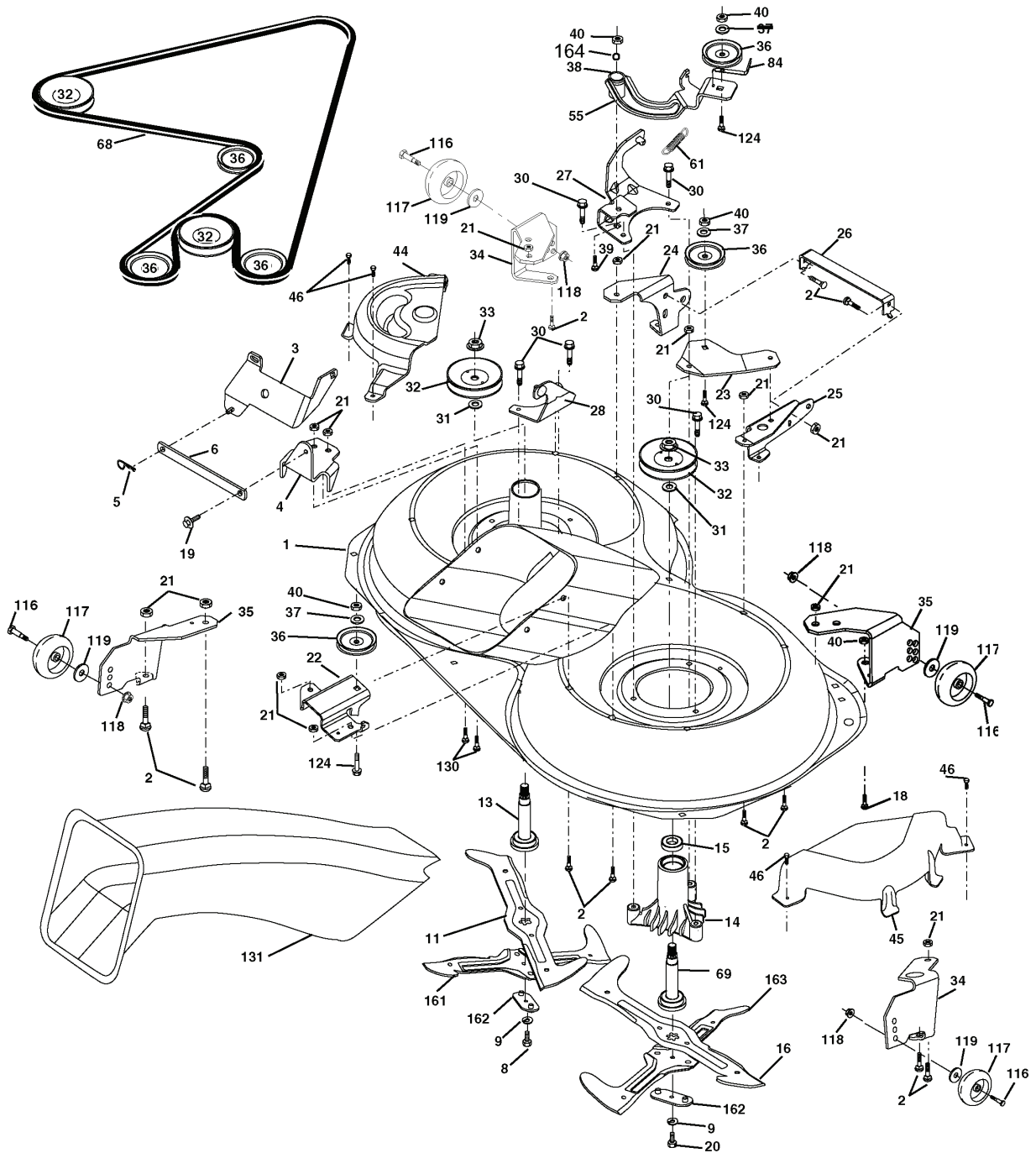

REF.	PART NO.	DESCRIPTION	REMARK	QTY.	KIT
5	532124670	RETAINER RING		1	
1	532169160	HOUSING		1	
2	872140506	BOLT		1	
3	532165569	BRACKET		1	
4	532169167	BRACKET		1	
5	532004939	SPRING		1	
6	532165557	ROD		1	
8	532181712	BOLT		1	
9	810030600	WASHER		1	
11	532180583	BLADE		1	
13	532137645	SHAFT		1	
14	532128774	BEARING HOUSING		1	
15	532110485	BEARING		1	
16	532180584	BLADE		1	
18	872110606	BOLT		1	
19	532132827	SPEC. BOLT		1	
20	532181713	BOLT		1	
21	873680500	NUT		1	
22	532169165	BRACKET		1	
23	532169166	BRACKET		1	
24	532169170	BRACKET		1	
25	532169171	BRACKET		1	
26	532165237	ROD		1	
27	532169172	BRACKET		1	
28	532169168	BRACKET		1	
30	532173984	SCREW		1	
31	532187690	WASHER		1	
32	532175707	MANDREL PULLEY		1	
33	532178342	NUT		1	
34	532179509	BRACKET		1	
40	873900600	NUT		1	
35	532176292	BRACKET		1	
36	532146763	PULLEY		1	
37	819131316	WASHER		1	
38	532169851	SPACER		1	
39	872110622	BOLT		1	
40	873680600	NUT		1	
44	532175538	COVER		1	
45	532175539	COVER		1	
46	532137729	SCREW		1	
55	532169849	LEVER		1	
61	532175159	SPRING		1	
68	532169178	BELT		1	
69	532165482	SHAFT		1	
84	532156085	BELT GUIDE		1	
116	532184219	BOLT		1	
117	532133957	WHEEL		1	
118	873930600	NUT		1	
119	819121414	WASHER		1	
124	872110612	BOLT		1	
130	872110506	BOLT		1	
131	532165661	PIPE		1	
161	532180424	BLADE		1	
162	532180878	ADAPTER		1	
163	532180425	BLADE		1	
--	532181857	BEARING HOUSING		1	
--	532181858	BEARING HOUSING		1	
--	532181770	HOUSING		1	
164	532124937	BEARING COL. STRG.		1	

# REPAIR PARTS

TRACTOR- -MODEL NO. CTH150XP (HECTH150KB), PRODUCT NO. 954 17 00-76  
MOWER LIFT

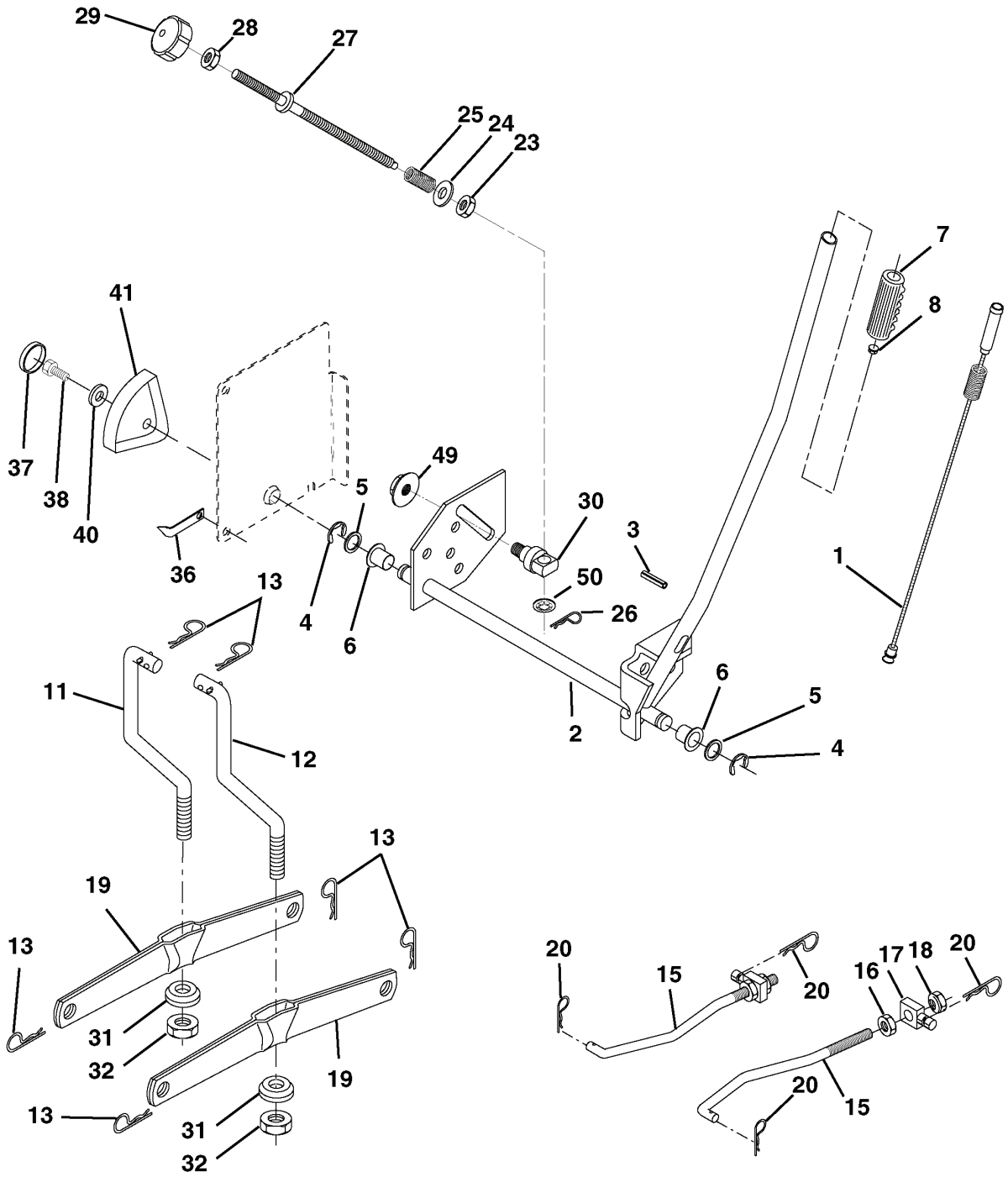

REF.	PART NO.	DESCRIPTION	REMARK	QTY.	KIT
1	532159460	WIRE		1	
2	532159471	LEVER		1	
3	532105767	PIN RETAINING SCREW		1	
4	812000002	RETAINER RING		1	
5	819211621	WASHER		1	
6	532120183	BEARING		1	
7	532125631	HANDLE		1	
8	532124526	KNOB		1	
11	532165829	ROD		1	
12	532165831	ROD		1	
13	532124670	RETAINER RING		1	
15	532173288	LINK		1	
16	873350800	NUT		1	
17	532175689	BRACKET		1	
18	873800800	NUT		1	
19	532139868	LEVER		1	
20	532163552	CLIP		1	
23	532110807	NUT		1	
24	819131016	WASHER		1	
25	532124874	SPRING		1	
26	532169484	PIN		1	
27	532126971	LEVER		1	
28	873350600	NUT		1	
29	532138057	KNOB		1	
30	532150233	TRUNNION		1	
31	532169865	BEARING		1	
32	873540600	NUT		1	
36	532155097	INDICATOR		1	
37	532123935	PLUG		1	
38	817060516	SCREW		1	
40	819112410	WASHER		1	
41	532123934	INDICATOR		1	
49	532145212	NUT		1	
50	532110452	NUT		1	

# REPAIR PARTS

TRACTOR- -MODEL NO. CTH150XP (HECTH150KB), PRODUCT NO. 954 17 00-76  
CHASSIS AND ENCLOSURES

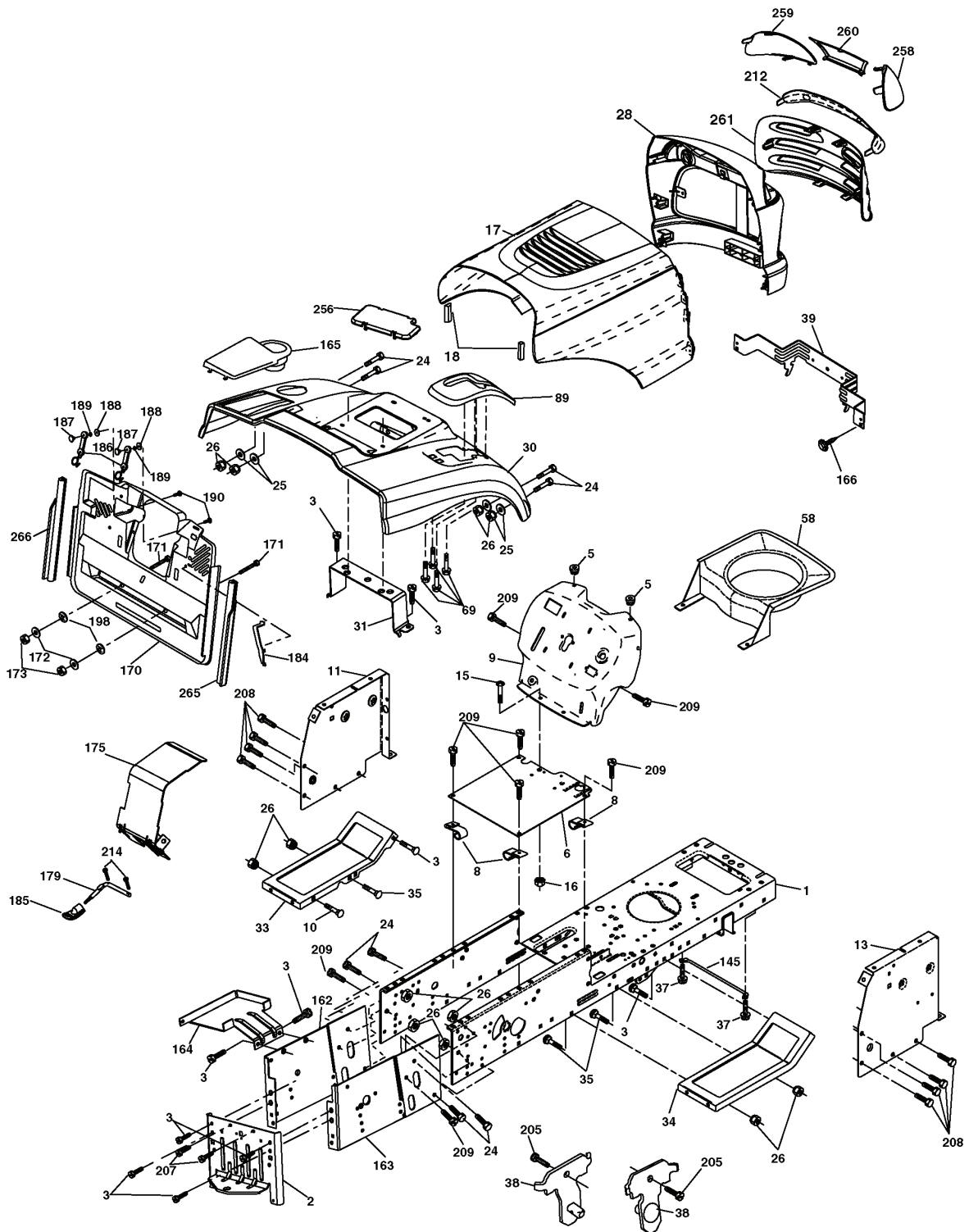



REF.	PART NO.	DESCRIPTION	REMARK	QTY.	KIT
1	532174620	CHASSIS		1	
2	532180384	DRAWBAR		1	
3	817060612	SCREW		1	
5	532155272	DAMPER		1	
6	532184419	PLATE		1	
8	532126471	CLIP		1	
9	532185209	PANEL		1	
10	872140608	BOLT		1	
11	532174996	DASHBOARD		1	
13	532172106	DASH		1	
15	874180512	SCREW		1	
16	873510500	NUT		1	
17	532185211	HOOD		1	
18	532184921	BUMPER		1	
24	874780616	BOLT		1	
25	819131312	WASHER		1	
26	873800600	NUT		1	
28	532183538	GRILL		1	
30	532179645	FENDER		1	
31	532165156	BRACKET		1	
33	532181057	FOOTREST		1	
34	532181058	FOOTREST		1	
35	872110606	BOLT		1	
37	817490508	SCREW		1	
38	532181748	BRACKET		1	
39	532174714	BRACKET PIVOT LASER LT		1	
69	532142432	SCREW		1	
89	532181099	CONSOLE		1	
145	532156524	SHAFT		1	
162	532180382	BRACKET		1	
163	532180383	BRACKET		1	
58	532184460	HOOD		1	
164	532165605	SUPPORT		1	
165	532181100	COVER		1	
166	532171875	SCREW		1	
170	532178862	PLATE		1	
171	872140620	BOLT		1	
172	819132016	WASHER		1	
173	873510600	NUT		1	
175	532180310	GUARD		1	
179	532180376	ROD		1	
184	532174662	BRACKET		1	
185	532181101	KNOB		1	
186	532160793	LATCH		1	
187	532125004	NUT		1	
188	819061216	WASHER		1	
189	810071000	WASHER		1	
190	871081010	SCREW		1	
198	532168937	WASHER		1	
205	817490608	SCREW		1	
207	817670508	SCREW		1	
208	817670608	SCREW		1	
209	817000612	SCREW		1	
212	532183548	INSERT		1	
214	532124788	RETAINER RING		1	
256	532181361	COVER		1	
258	532185213	LENS		1	
259	532185214	LENS		1	
260	532185216	INSERT		1	
261	532185212	INSERT		1	
265	532185704	SEALING		1	
266	532185703	SEALING		1	

## REPAIR PARTS

TRACTOR- -MODEL NO. CTH150XP (HECTH150KB), PRODUCT NO. 954 17 00-76  
DECALS

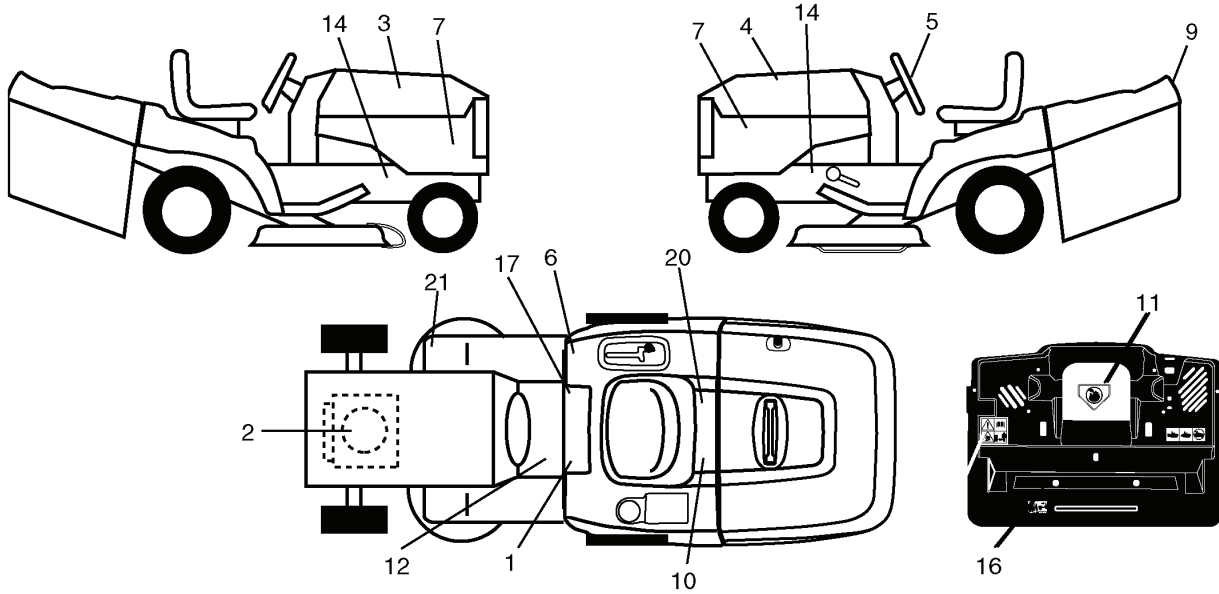

REF.	PART NO.	DESCRIPTION	REMARK	QTY.	KIT
1	532145498	DECAL		1	
2	532185435	DECALC.VOLLUTE MOTEUR		1	
3	532184833	DECAL		1	
4	532184834	DECAL		1	
5	532170564	DECAL		1	
6	532180432	DECAL		1	
7	532185184	LABEL		1	
9	532150617	DECAL		1	
10	532145005	DECAL		1	
11	532182166	DECAL		1	
12	532159737	DECAL		1	
14	532159736	DECAL		1	
16	532180435	DECAL		1	
17	532140837	DECAL		1	
20	532166960	DECAL		1	
21	532166286	DECAL		1	
--	532182621	DECAL		1	
--	532138311	DECAL		1	
--	532181090	PLATE		1	
--	532181091	PLATE		1	
--	532183938	OPERATORS MANUAL		1	
--	532183939	OPERATORS MANUAL		1	
	PART NO.		REMARK		KIT