

265 RX, 19921800001-19954500000

SPARE PARTS LIST

L * compl 502 00 14-02

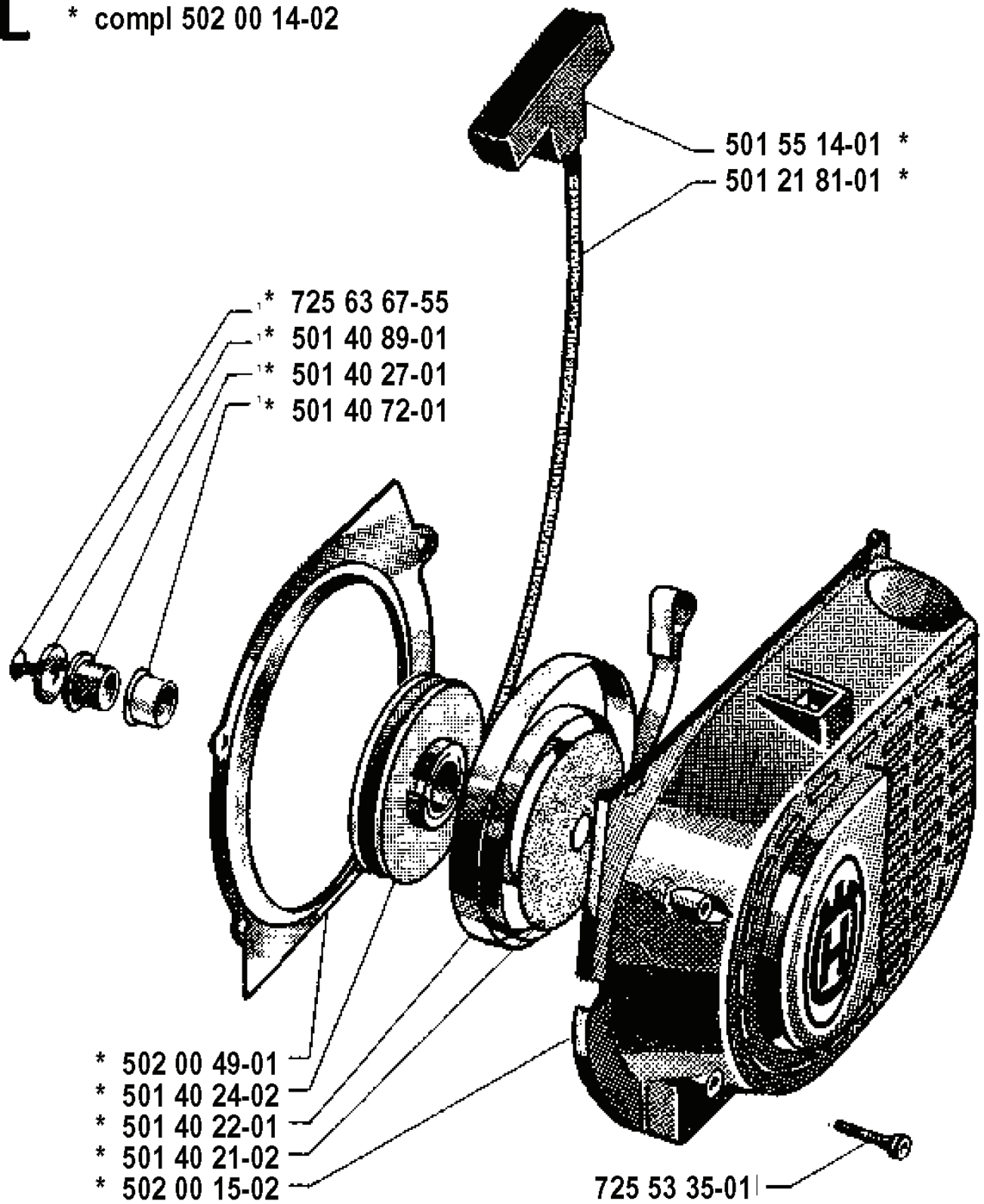

REF.	PART NO.	DESCRIPTION	REMARK	QTY.	KIT
5020014-02	502001402	STARTER ASSY		1	
7256367-55	725636755	SCREW IHCSFM		1	
5014089-01	501408901	WASHER		1	
5014027-01	501402701	BEARING SHAFT		1	
5014072-01	501407201	BUSHING		1	
5020049-01	502004901	SPACING PLATE		1	
5014024-02	501402402	STARTER PULLEY		1	
5014022-01	501402201	RECOIL SPRING		1	
5014021-02	501402102	DAMPER		1	
5020015-02	502001502	STARTER HOUSING		1	
7255335-01	725533501	SCREW IHSCM		1	
5012181-01	501218101	STARTER ROPE ASSY		1	
5015514-01	501551401	STARTER HANDLE		1	

B

* compl 502 25 80-01

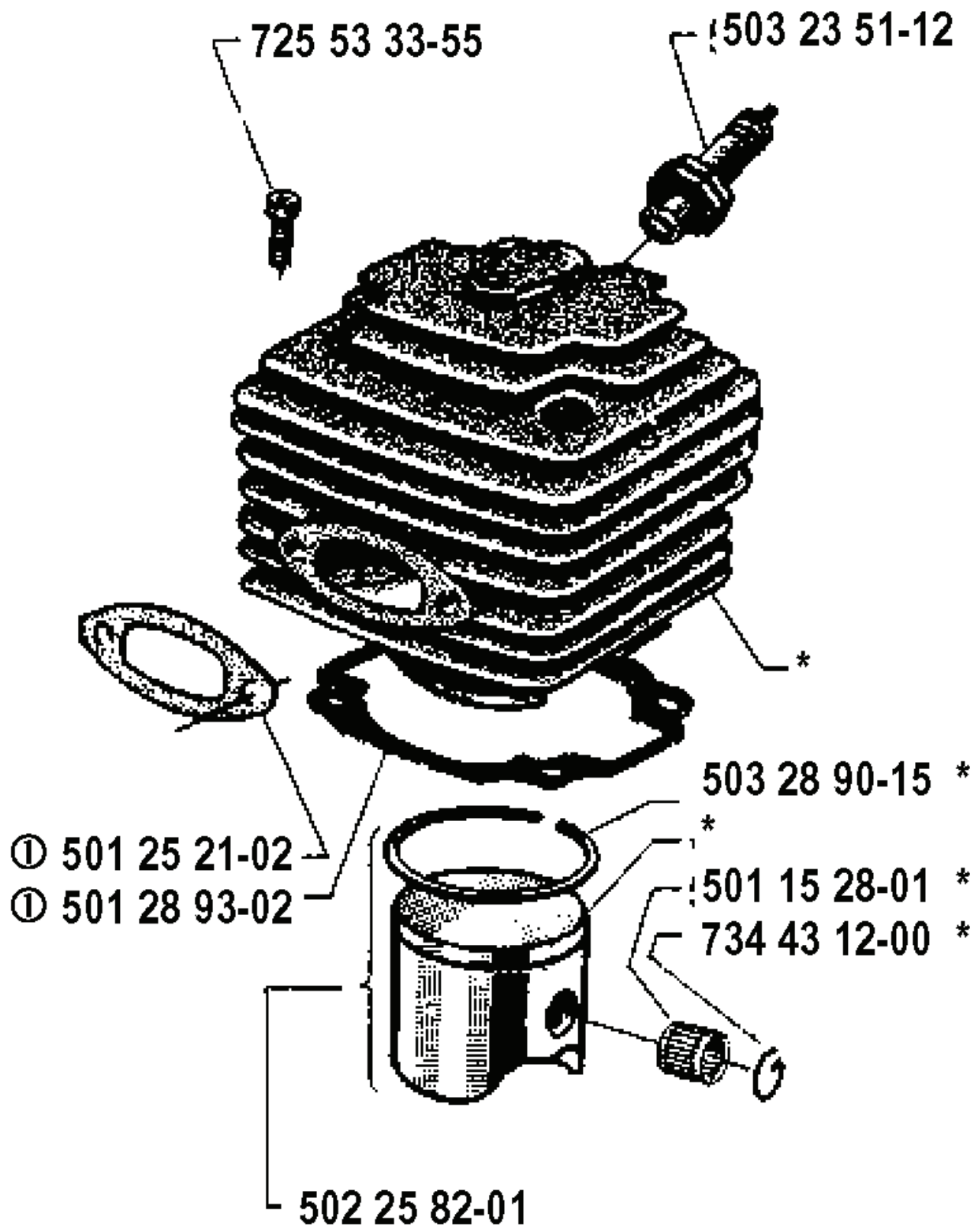

REF.	PART NO.	DESCRIPTION	REMARK	QTY.	KIT
502 25 80-01	502258001	CYLINDER ASSY		1	
725 53 33-55	725533355	SCREW IHSCM		1	
501 25 21-02	501252102	GASKET		1	
501 28 93-02	501289302	GASKET		1	
502 25 82-01	502258201	PISTON ASSY		1	
734 43 12-00	734431200	ERROR		1	
501 15 28-01	501152801	NEEDLE BEARING		1	
503 28 90-15	503289015	PISTON RING		1	
503 23 51-12	503235112	SPARK PLUG		1	

E * compl 502 00 25-03

503 20 32-28 *

502 05 24-03 *

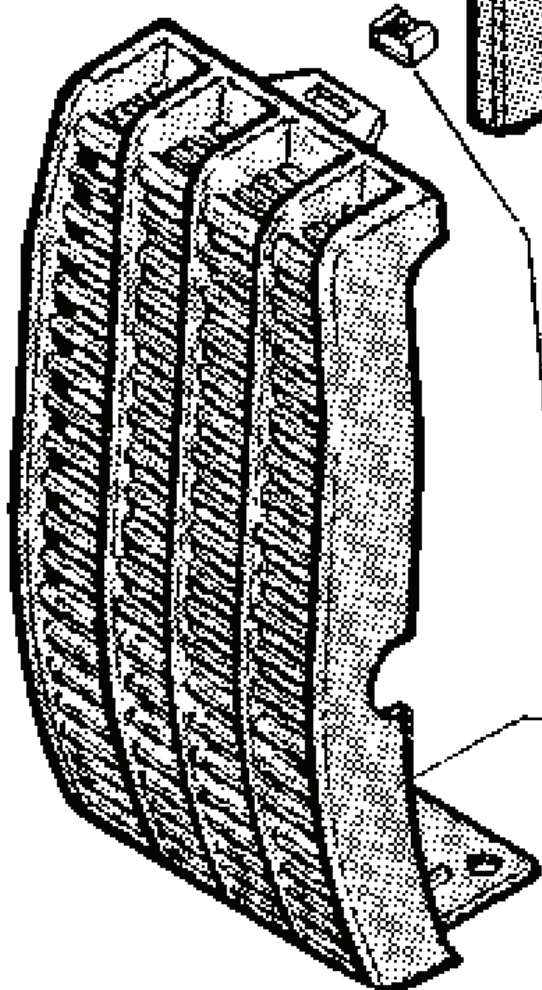
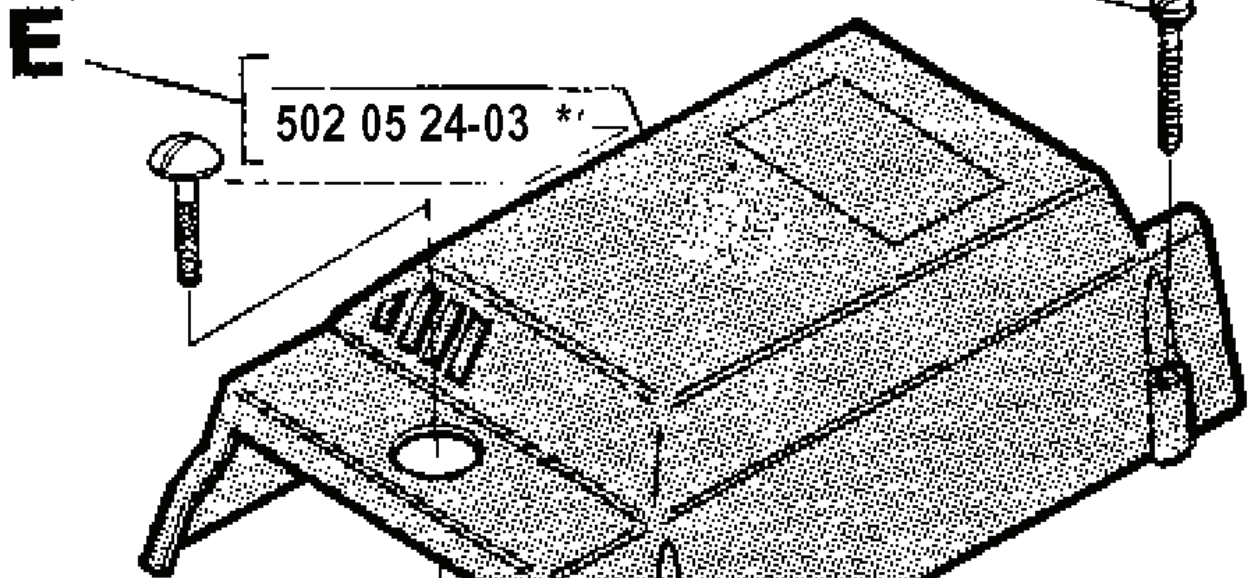

* compl 502 10 64-03

* compl 502 10 64-04 (SA)

733 61 13-01

503 22 62-01 *

729 43 42-42 *



REF.	PART NO.	DESCRIPTION	REMARK	QTY.	KIT
502 00 25-03	502002503	CYLINDER COVER ASSY		1	
502 05 24-03	502052403	SCREW		1	
729 43 42-42	729434242	SCREW SLCSRT		1	
503 22 62-01	503226201	NUT		1	
733 61 13-01	733611301	CAGE NUT		1	
502 10 64-04	502106404	HEAT PROTECTOR	SA	1	
502 10 64-03	502106403	HEAT PROTECTOR		1	
503 20 32-28	503203228	SCREW		1	

REF.	PART NO.	DESCRIPTION	REMARK	QTY.	KIT
502 00 16-04	502001604	FUEL TANK ASSY		1	
503 44 32-01	503443201	FUEL FILTER		1	
502 00 21-02	502002102	FUEL HOSE		1	
502 01 39-01	502013901	GROMMET		1	
502 03 86-03	502038603	TANK CAP ASSY		1	

J * compl 502 00 20-01

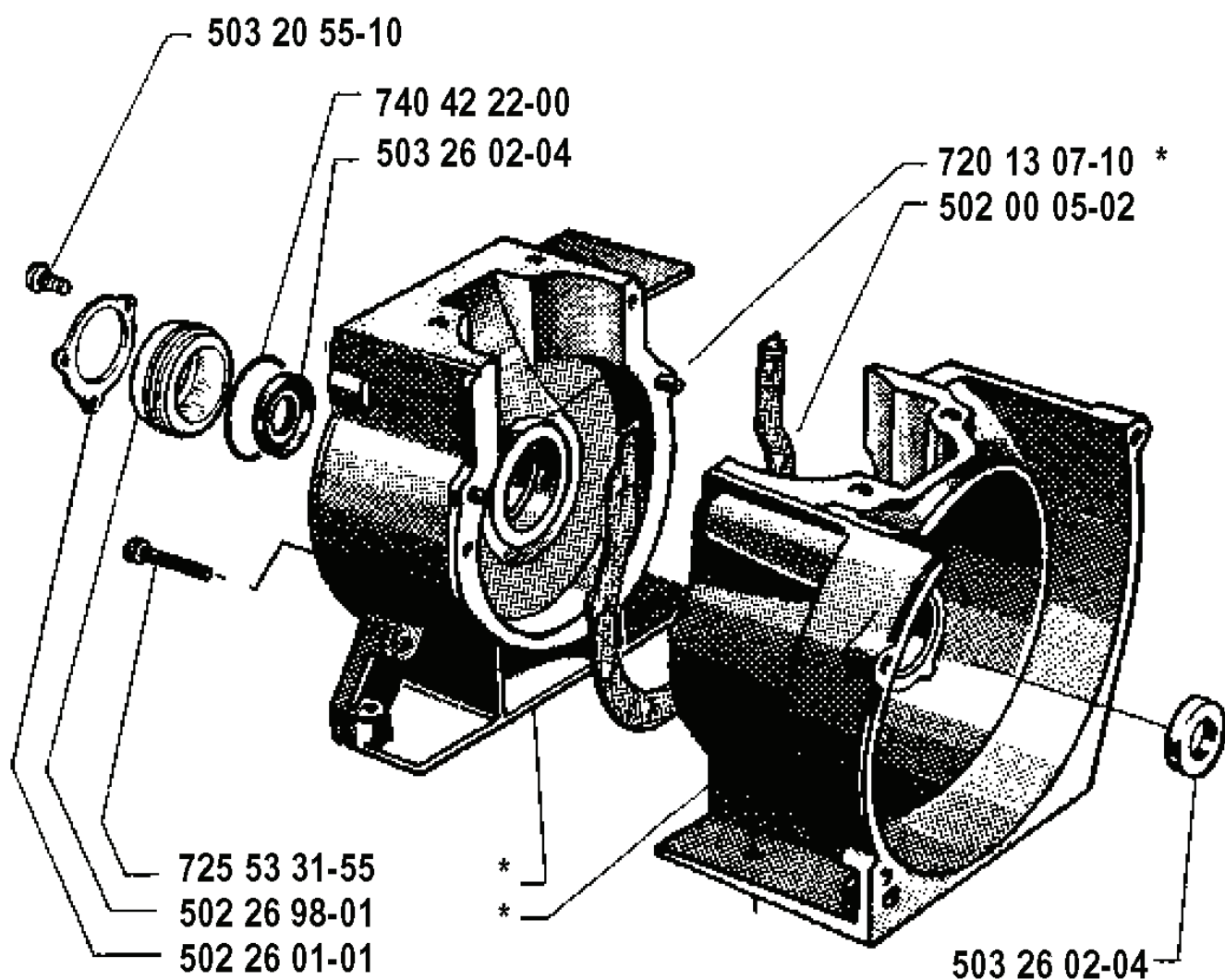

REF.	PART NO.	DESCRIPTION	REMARK	QTY.	KIT
502 00 20-01	502002001	CRANKCASE		1	
503 20 55-10	503205510	SCREW CITXPANM		1	
740 42 22-00	740422200	O-RING		1	
725 53 31-55	725533155	SCREW IHSCM		1	
502 26 98-01	502269801	SEALING RING HOLDER		1	
502 26 01-01	502260101	BEARING CAGE		1	
503 26 02-04	503260204	SEALING RING		1	
502 00 05-02	502000502	CRANKCASE		1	
720 13 07-10	720130710	PARALLEL PIN		1	

H

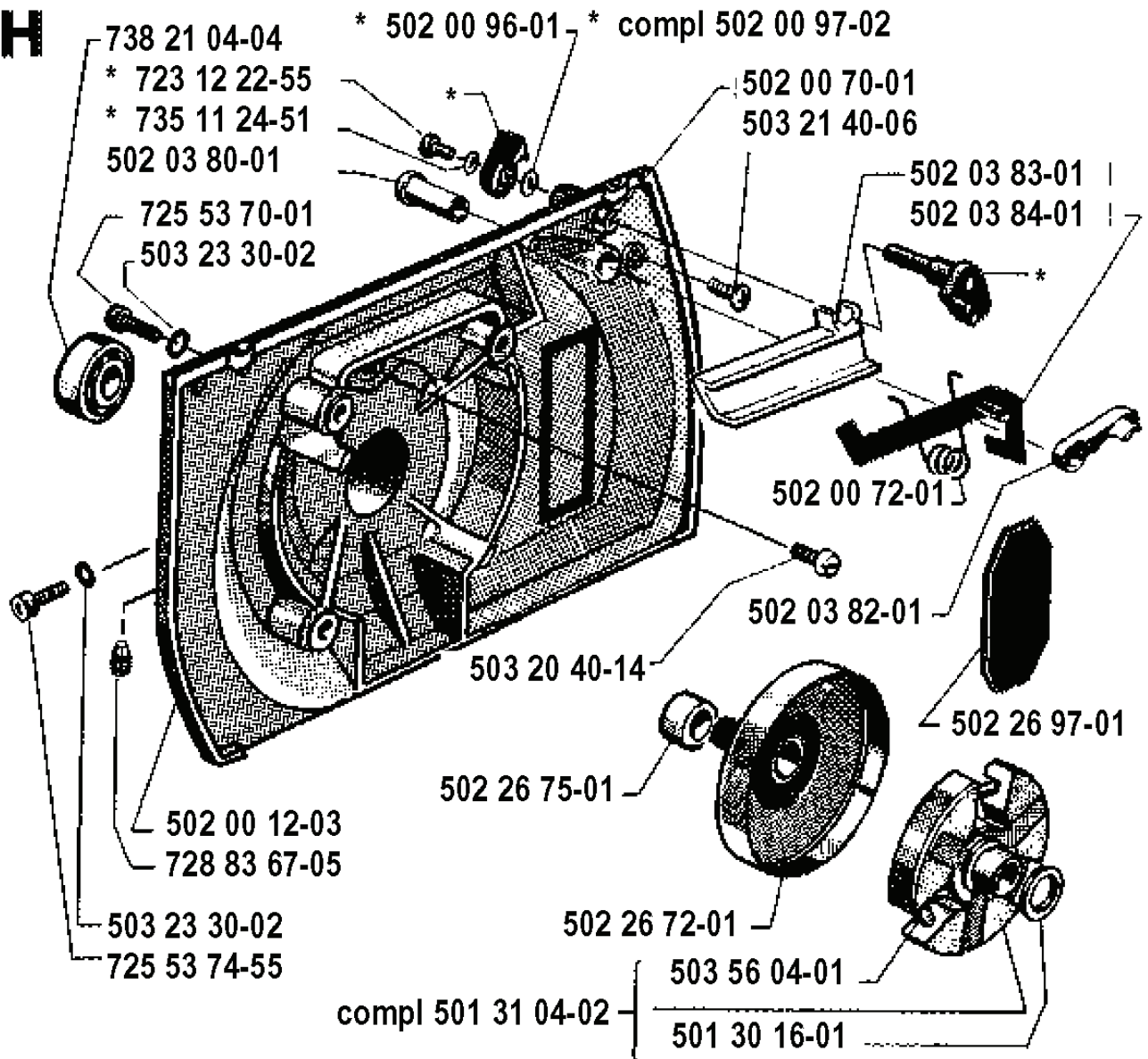

REF.	PART NO.	DESCRIPTION	REMARK	QTY.	KIT
738 21 04-04	738210404	BALL BEARING		1	
723 12 22-55	723122255	SCREW SLCHM		1	
735 11 24-51	735112451	SPRING WASHER		1	
502 03 80-01	502038001	BUSHING		1	
725 53 70-01	725537001	SCREW IHSCM		1	
502 00 12-03	502001203	CLUTCH COVER ASSY		1	
728 83 67-05	728836705	SCREW IHSETM		1	
503 23 30-02	503233002	WASHER		1	
725 53 74-55	725537455	SCREW IHSCM		1	
501 31 04-02	501310402	CLUTCH ASSY		1	
502 26 75-01	502267501	SPACER RING		1	
503 20 40-14	503204014	SCREW SLCSFM		1	
502 00 96-01	502009601	WASHER		1	
502 00 72-01	502007201	SPRING		1	
502 03 82-01	502038201	THROTTLE LEVER		1	
502 26 72-01	502267201	CLUTCH DRUM ASSY		1	
503 56 04-01	503560401	CLUTCH SPRING		1	
501 30 16-01	501301601			1	
502 26 97-01	502269701	SPACER		1	
502 03 84-01	502038401	SPRING		1	
502 03 83-01	502038301	SPRING RETAINER		1	
503 21 40-06	503214006	SCREW CCRPANT		1	
502 00 70-01	502007001	BEARING BUSH		1	
502 00 97-02	502009702	STARTER THROTTLE LOCK		1	

M * compl 502 01 20-01

Tillotson HS 121 A

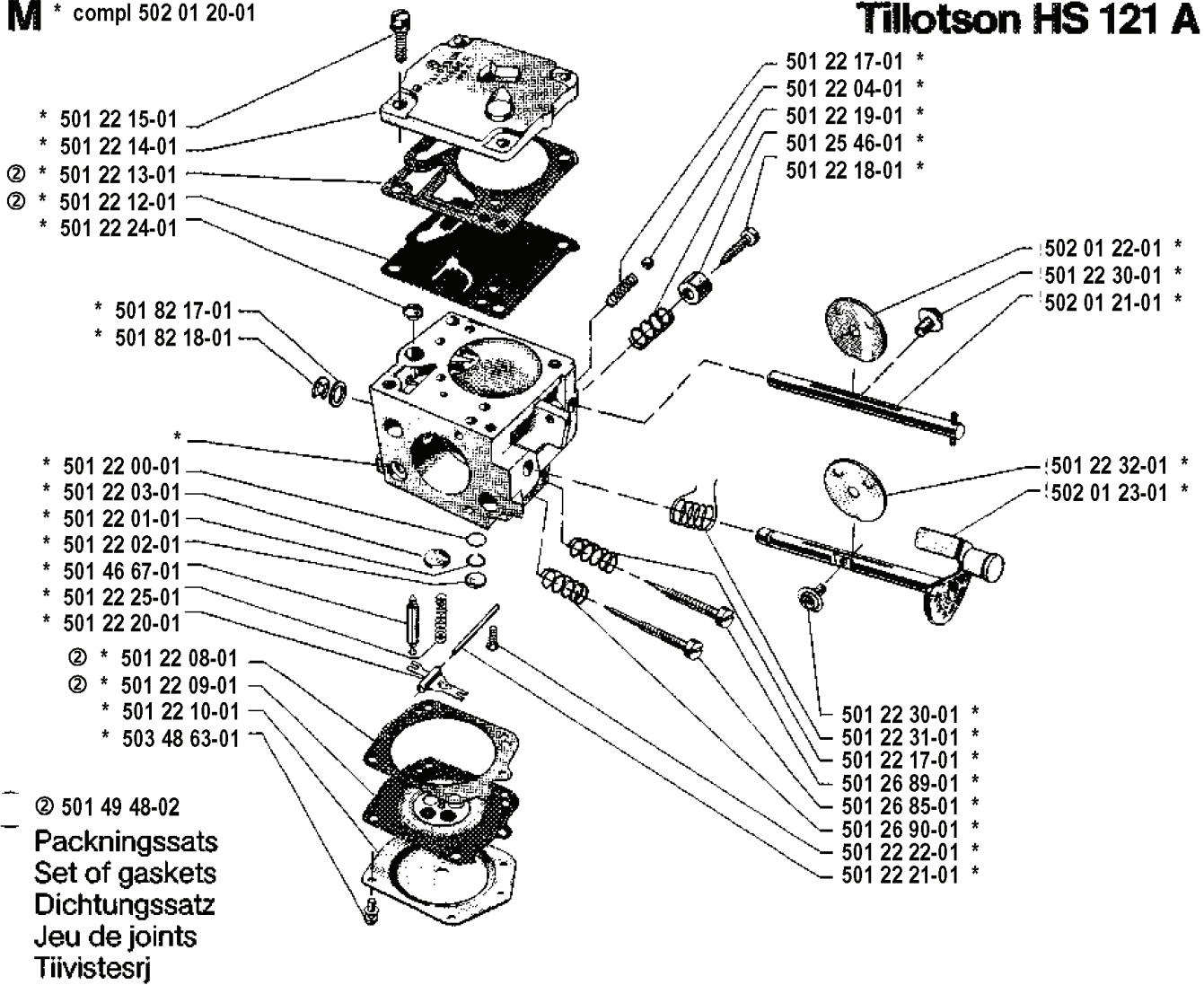

REF.	PART NO.	DESCRIPTION	REMARK	QTY.	KIT
5020120-01	502012001	CARBURETTOR		1	
5012215-01	501221501	SCREW		1	
5012214-01	501221401	COVER		1	
5012213-01	501221301	GASKET	501 49 48-02 SET OF GASKETS	1	
5012212-01	501221201	DIAGRAM	501 49 48-02 SET OF GASKETS	1	
5012224-01	501222401	SCREEN		1	
5018217-01	501821701	WASHER		1	
5018218-01	501821801	THROTTLE SH.'E'RING		1	
5012200-01	501220001	BODY CHANNEL SCREEN		1	
5012203-01	501220301	PLUG		1	
5012201-01	501220101	RETAINER RING		1	
5012202-01	501220201	PLUG		1	
5014667-01	501466701	VALVE		1	
5012225-01	501222501	SPRING		1	
5012220-01	501222001	LEVER		1	
5012208-01	501220801	GASKET	501 49 48-02 SET OF GASKETS	1	
5012209-01	501220901	DIAPHRAGM	501 49 48-02 SET OF GASKETS	1	
5012210-01	501221001	COVER		1	
5034863-01	503486301	SCREW		1	
5012221-01	501222101	PIN		1	
5012222-01	501222201	SCREW		1	
5012690-01	501269001	SPRING		1	
5012685-01	501268501	SCREW		1	
5012689-01	501268901	SCREW		1	
5012217-01	501221701	SPRING		1	
5012231-01	501223101	THROTTLE SH.SPRING		1	
5012230-01	501223001	SCREW&LOCKWASHER		1	
5020123-01	502012301	THROTTLE SH.&LEVER		1	
5012232-01	501223201	PLATE		1	
5020121-01	502012101	CHOKE SHAFT		1	
5020122-01	502012201	VALVE		1	
5012218-01	501221801	IDLE SPEED SCREW		1	
5012546-01	501254601	BUSHING		1	
5012219-01	501221901	IDLE SPEED SCREW		1	
5012204-01	501220401	BALL		1	

K

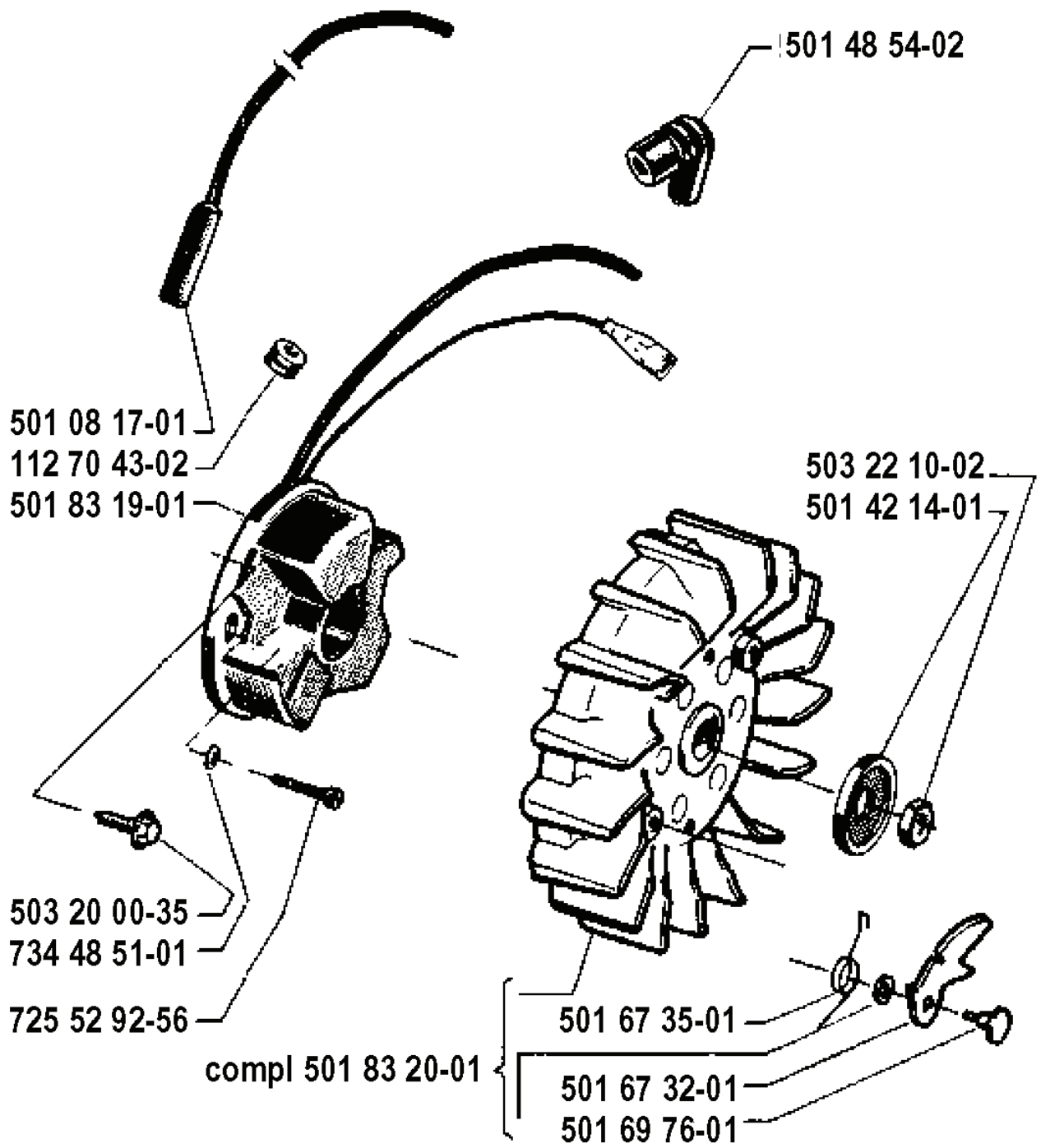

REF.	PART NO.	DESCRIPTION	REMARK	QTY.	KIT
5010817-01	501081701	IGNITION CABLE		1	
1127043-02	112704302	GROMMET		1	
5018319-01	501831901	ANCHOR PLATE		1	
5032000-35	503200035	SCREW EHHFM		1	
7344851-01	734485101	WASHER		1	
7255292-56	725529256	SCREW		1	
5018320-01	501832001	FLYWHEEL ASSY		1	
5016976-01	501697601	REPAIR KIT		1	
5016732-01	501673201	PAWL		1	
5016735-01	501673501	SPRING		1	
5014214-01	501421401	WASHER		1	
5032210-02	503221002	HEXAGON NUT		1	
5014854-02	501485402	SPARK PLUG CAP		1	

O

Delivery as spare part only

Nur als Ersatzteil lieferbar

Livrable seulement comme pièce de rechange

Solo como repuesto

Levereras endast som reservdel

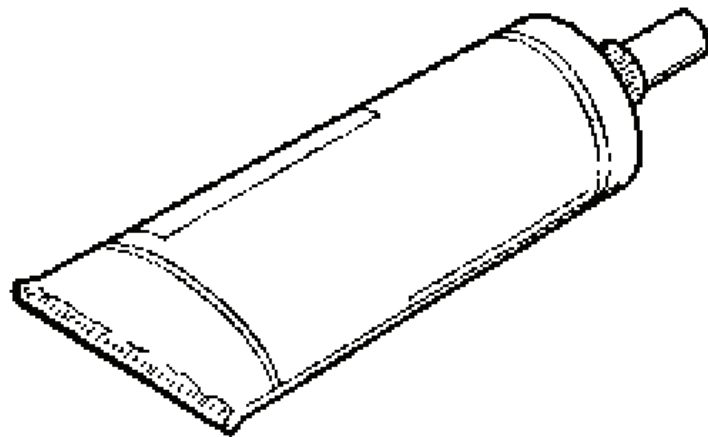

502 51 27-01

REF.	PART NO.	DESCRIPTION	REMARK	QTY.	KIT
5025127-01	502512701	GREASE		1	

N

* compl 502 02 00-02

**Accessoires
Zubehöre
Accessoires
Accesorios
Tillbehör**

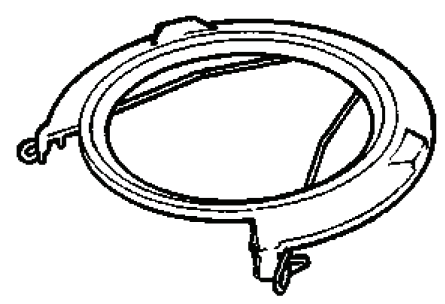
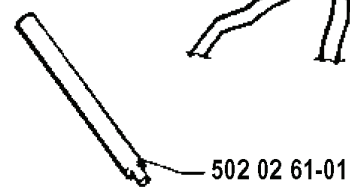
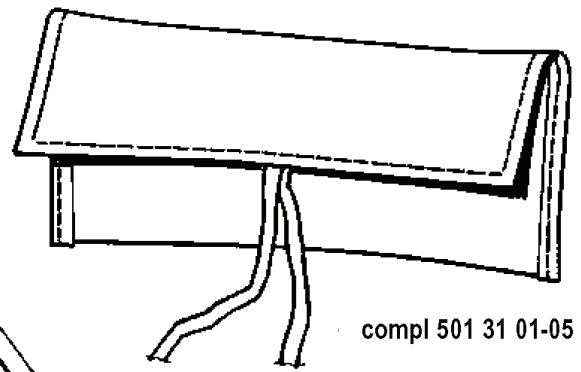
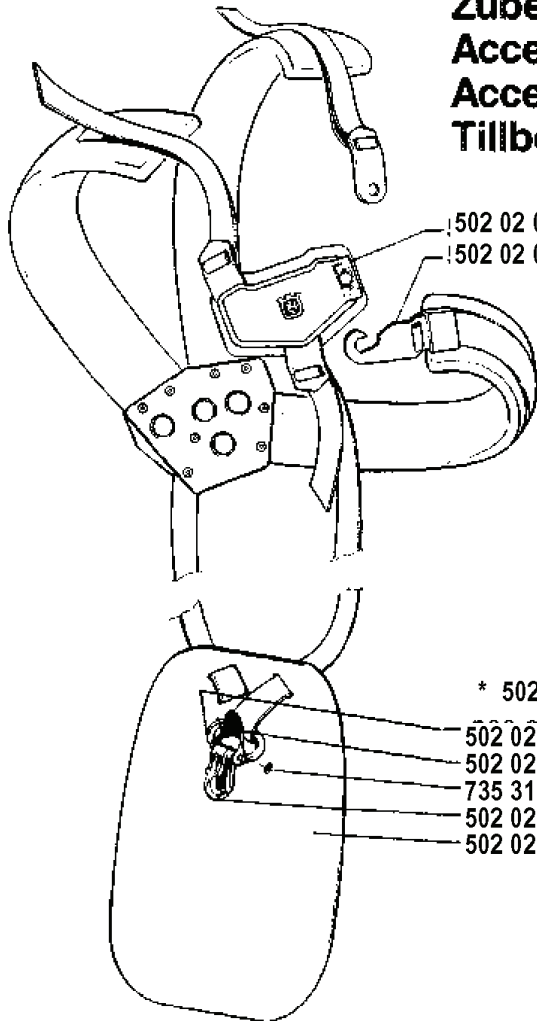

REF.	PART NO.	DESCRIPTION	REMARK	QTY.	KIT
502 02 00-02	502020002	HARNES		1	
502 02 27-01	502022701	HIP PAD		1	
502 02 29-02	502022902	HOOK		1	
735 31 09-20	735310920	E-CLIP		1	
502 02 30-02	502023002	LOCK		1	
502 02 38-01	502023801	SPRING		1	
502 02 28-01	502022801	HOOK		1	
502 02 06-01	502020601	CLAMP COMPL.		1	
502 02 01-01	502020101	FRONT PIECE		1	
502 03 64-01	502036401	TRANSPORT GUARD	12	1	
502 03 55-03	502035503	TRANSPORT GUARD	8	1	
502 02 61-01	502026101	STOP		1	
501 31 01-05	501310105	TOOL KIT		1	

D * compl 502 00 27-04

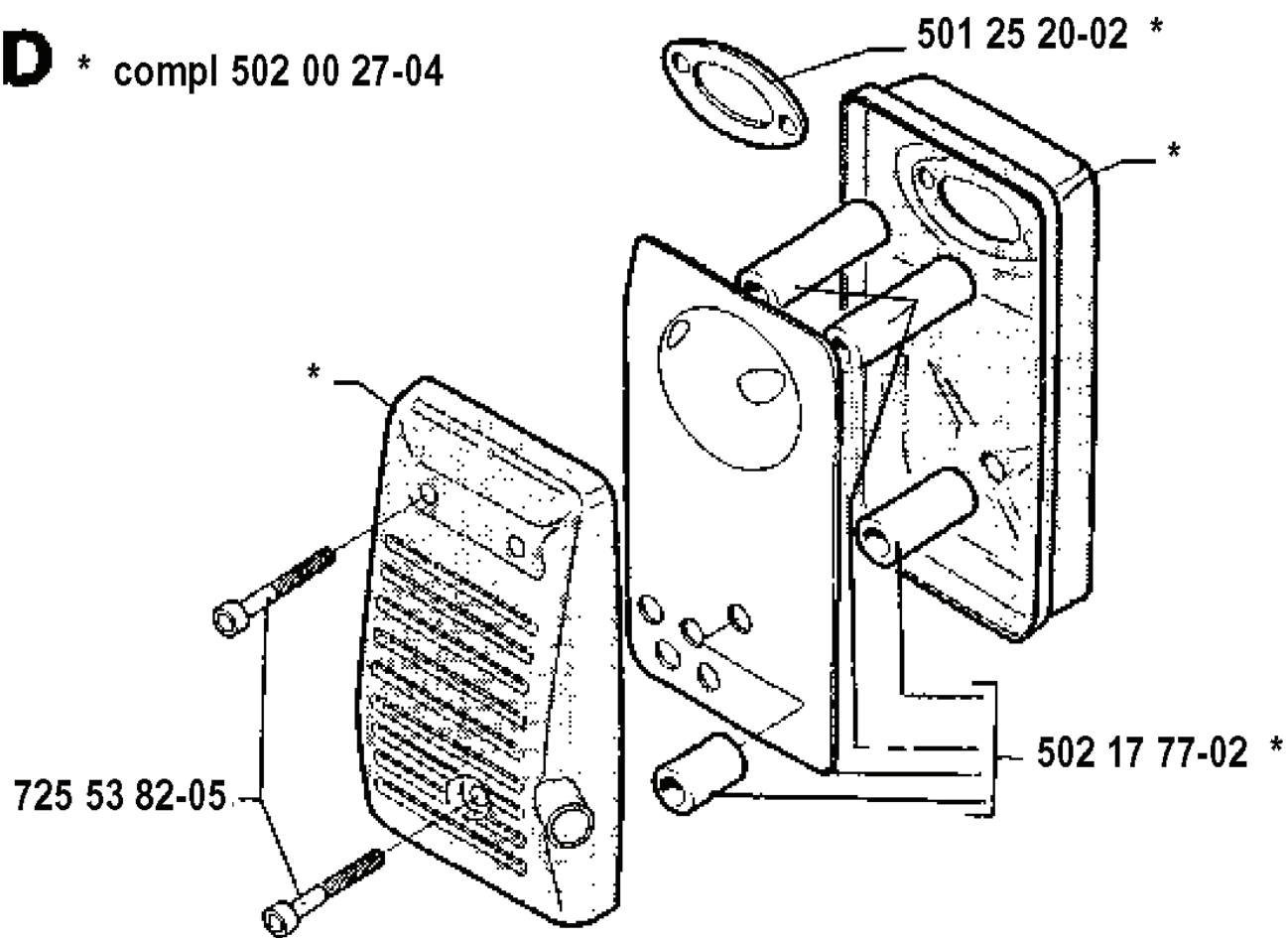

** compl 502 15 49-03

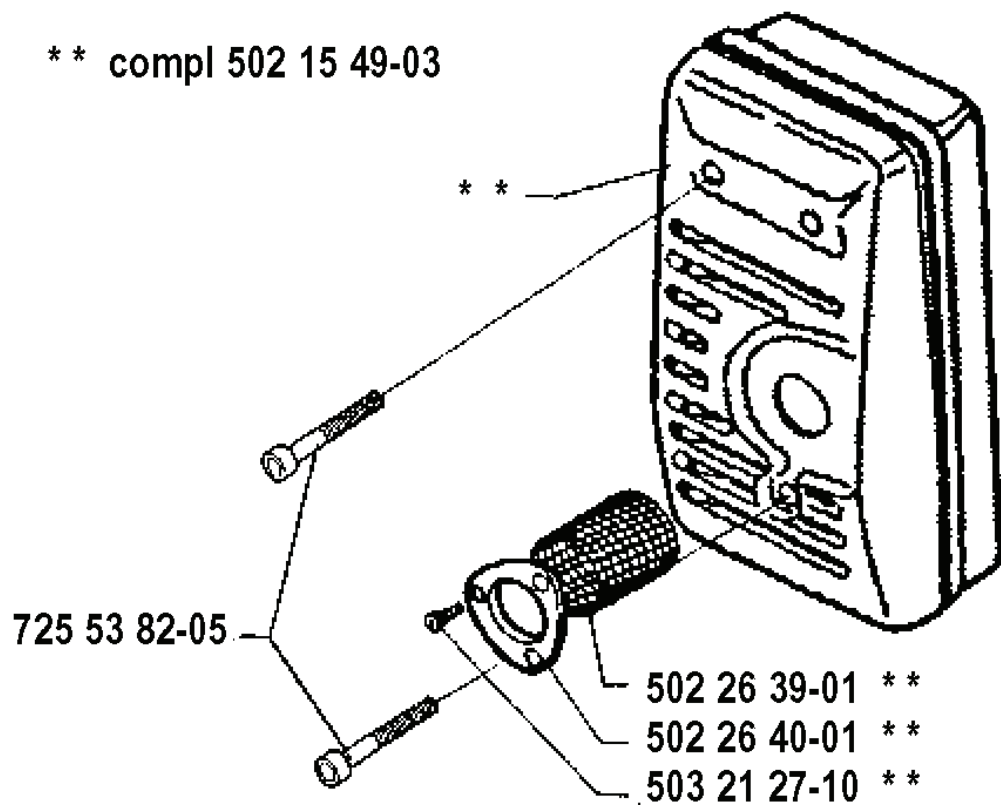

502 26 39-01 **

502 26 40-01 **

503 21 27-10 **

REF.	PART NO.	DESCRIPTION	REMARK	QTY.	KIT
502 00 27-04	502002704	MUFFLER ASSY		1	
725 53 82-05	725538205	SCREW IHSCM		1	
502 15 49-03	502154903	MUFFLER FF		1	
503 21 27-10	503212710	SCREW CCRPANT		1	
502 26 40-01	502264001	HUB CAP		1	
502 26 39-01	502263901	SPARK ARRESTER		1	
502 17 77-02	502177702	SATS SKÄRMPLÅT		1	
501 25 20-02	501252002	FLANGE		1	

C

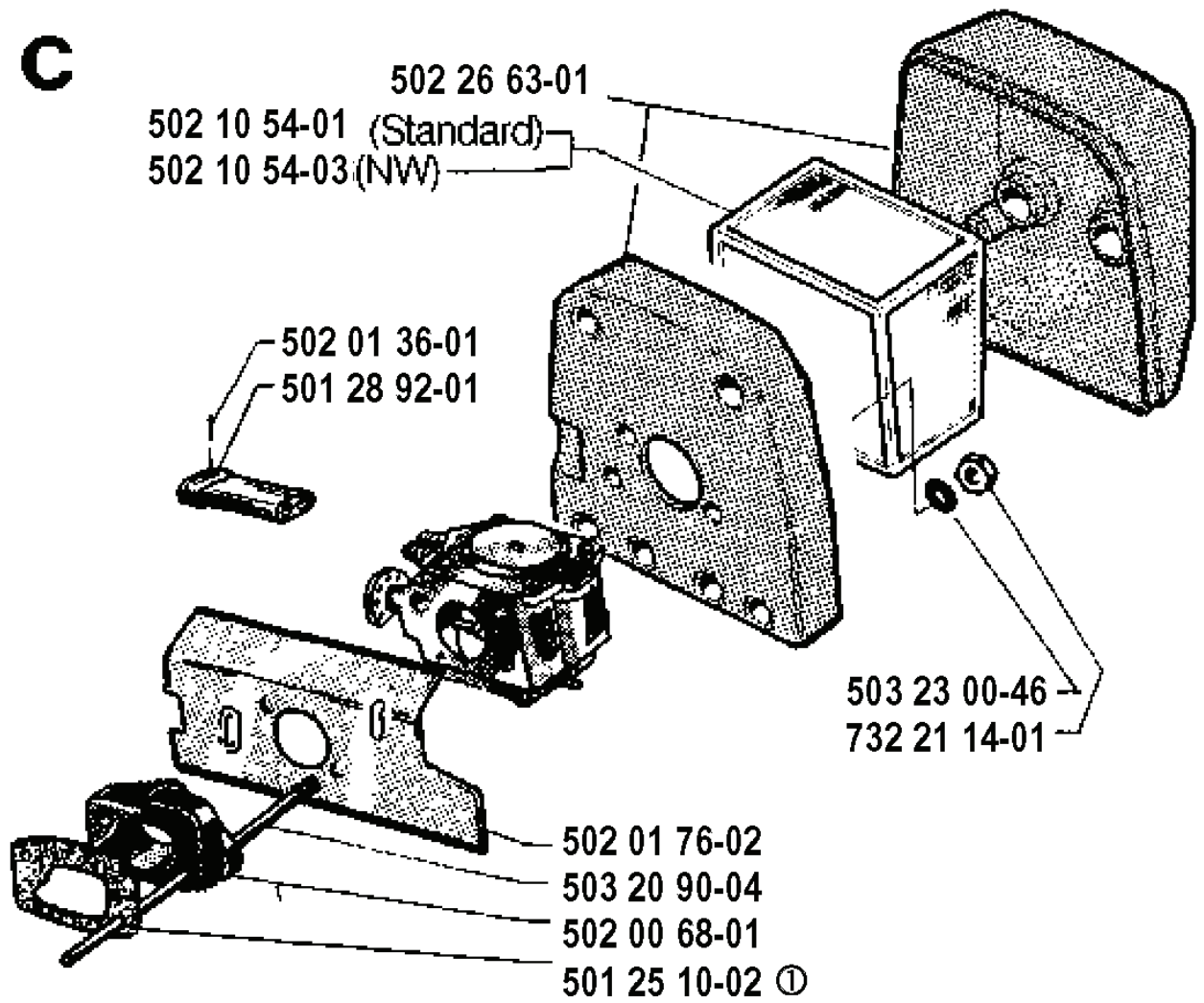

REF.	PART NO.	DESCRIPTION	REMARK	QTY.	KIT
502 26 63-01	502266301	KIT		1	
502 10 54-01	502105401	AIR FILTER ASSY	STANDARD	1	
502 10 54-03	502105403	AIR FILTER ASSY	NW	1	
502 01 36-01	502013601	RUND TRÅDSPIK 1.5X10		1	
501 28 92-01	501289201	GUIDE BUSHING		1	
502 01 76-02	502017602	INTERMEDIATE WALL		1	
503 20 90-04	503209004	SCREW PIN		1	
502 00 68-01	502006801	MANIFOLD		1	
501 25 10-02	501251002	GASKET		1	
732 21 14-01	732211401	LOCK NUT		1	
503 23 00-46	503230046	WASHER		1	

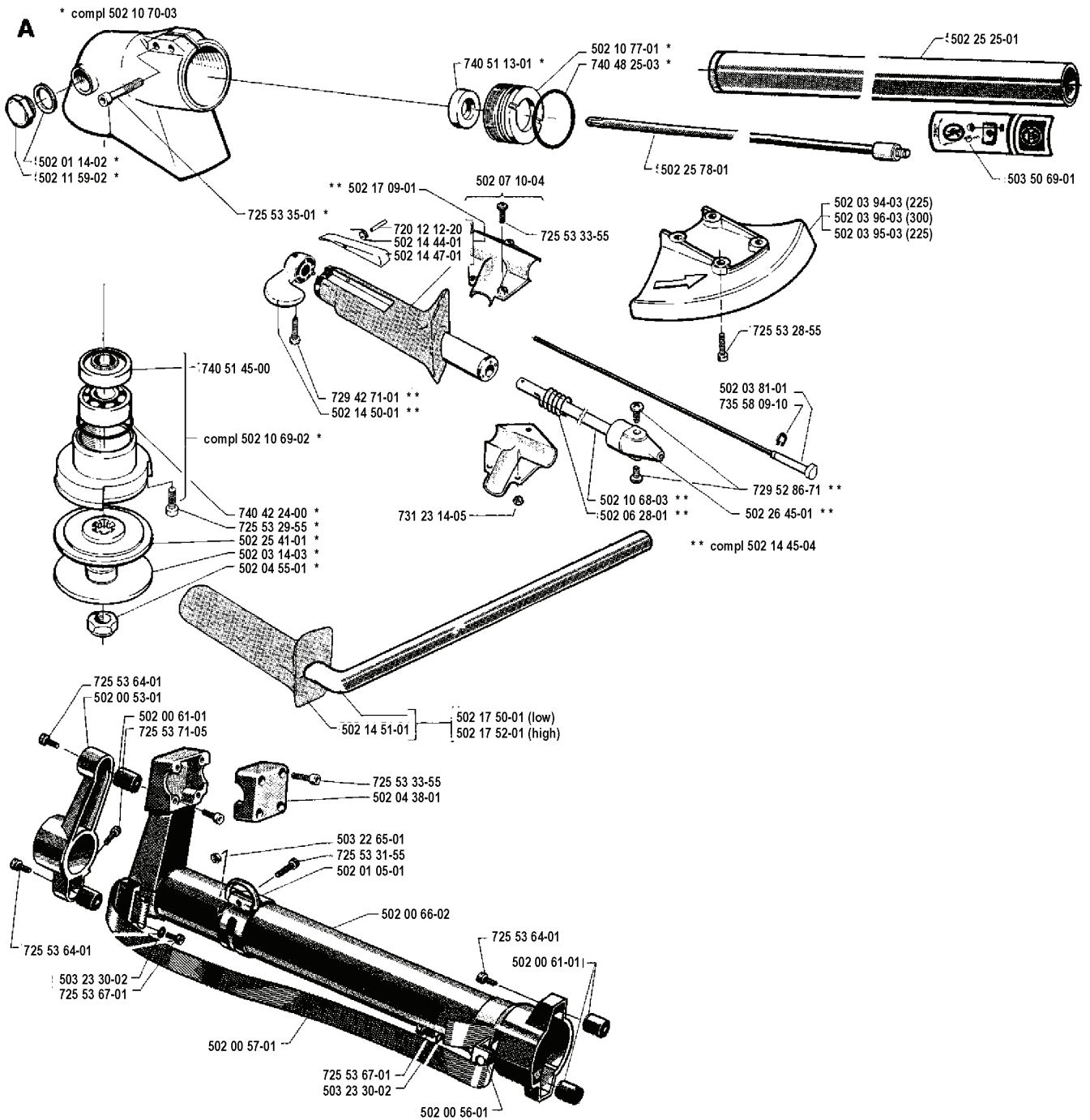

REF.	PART NO.	DESCRIPTION	REMARK	QTY.	KIT
502 10 70-03	502107003	GEAR HOUSING ASSY		1	
502 01 14-02	502011402	GASKET		1	
502 11 59-02	502115902	PLUG		1	
725 53 64-01	725536401	SCREW IHSCM		1	
502 00 53-01	502005301	RETAINER		1	
725 53 71-05	725537105	SCREW		1	
503 23 30-02	503233002	WASHER		1	
502 00 57-01	502005701	SADDLE GIRTH		1	
725 53 67-01	725536701	SCREW		1	
502 00 56-01	502005601	BELT TENSIONER		1	
502 00 61-01	502006101	ANTIVIBRATION ELEMENT		1	
502 00 66-02	502006602	SUSPENSION		1	
502 01 05-01	502010501	EYELET		1	
725 53 31-55	725533155	SCREW IHSCM		1	
503 22 65-01	503226501	SQUARE NUT		1	
502 04 38-01	502043801	HANDLEBAR BRACKET		1	
725 53 33-55	725533355	SCREW IHSCM		1	
502 14 51-01	502145101	HANDLE		1	
502 04 55-01	502045501	NUT		1	
502 03 14-03	502031403	SUPPORT FLANGE		1	
502 25 41-01	502254101	DRIVER		1	
725 53 29-55	725532955	SCREW IHSCM		1	
740 42 24-00	740422400	O-RING		1	
502 10 69-02	502106902	GEAR CASE COVER		1	
740 51 45-00	740514500	SEALING RING		1	
725 53 35-01	725533501	SCREW IHSCM		1	
729 42 71-01	729427101			1	
502 14 50-01	502145001	THROTTLE TRIGGER		1	
731 23 14-05	731231405	HEXAGON NUT		1	
502 17 50-01	502175001	HANDLEBAR LEFT	LOW	1	
502 17 52-01	502175201	HANDLEBAR	HIGH	1	
502 06 28-01	502062801	RECOIL SPRING		1	
502 10 68-03	502106803	TUBULAR SHAFT		1	
502 14 47-01	502144701	THROTTLE LOCKOUT		1	
502 14 44-01	502144401	SPRING		1	
720 12 12-20	720121220	PARALLEL PIN		1	
502 17 09-01	502170901	HANDLEBAR RIGHT		1	
740 51 13-01	740511301	SEALING RING		1	
502 07 10-04	502071004	RETAINER		1	
502 25 78-01	502257801	DRIVE SHAFT ASSY		1	
740 48 25-03	740482503	O-RING		1	

REF.	PART NO.	DESCRIPTION	REMARK	QTY.	KIT
502 10 77-01	502107701	STOP SLEEVE		1	
502 14 45-04	502144504	HANDLE ASSY		1	
502 26 45-01	502264501	SPRING GUIDE		1	
729 52 86-71	729528671	SCREW CCRPANT		1	
735 58 09-10	735580910	LOCKWASHER		1	
502 03 81-01	502038101	SHAFT FLEXIBLE		1	
725 53 28-55	725532855	SCREW		1	
502 03 95-03	502039503	SAW BLADE GUARD	225	1	
502 03 96-03	502039603	BLADE GUARD	300	1	
502 03 94-03	502039403	SAW BLADE GUARD	225	1	
503 50 69-01	503506901	DECAL		1	
502 25 25-01	502252501	TUBE DRIVESHAFT ASSY		1	

F * compl 501 55 61-01

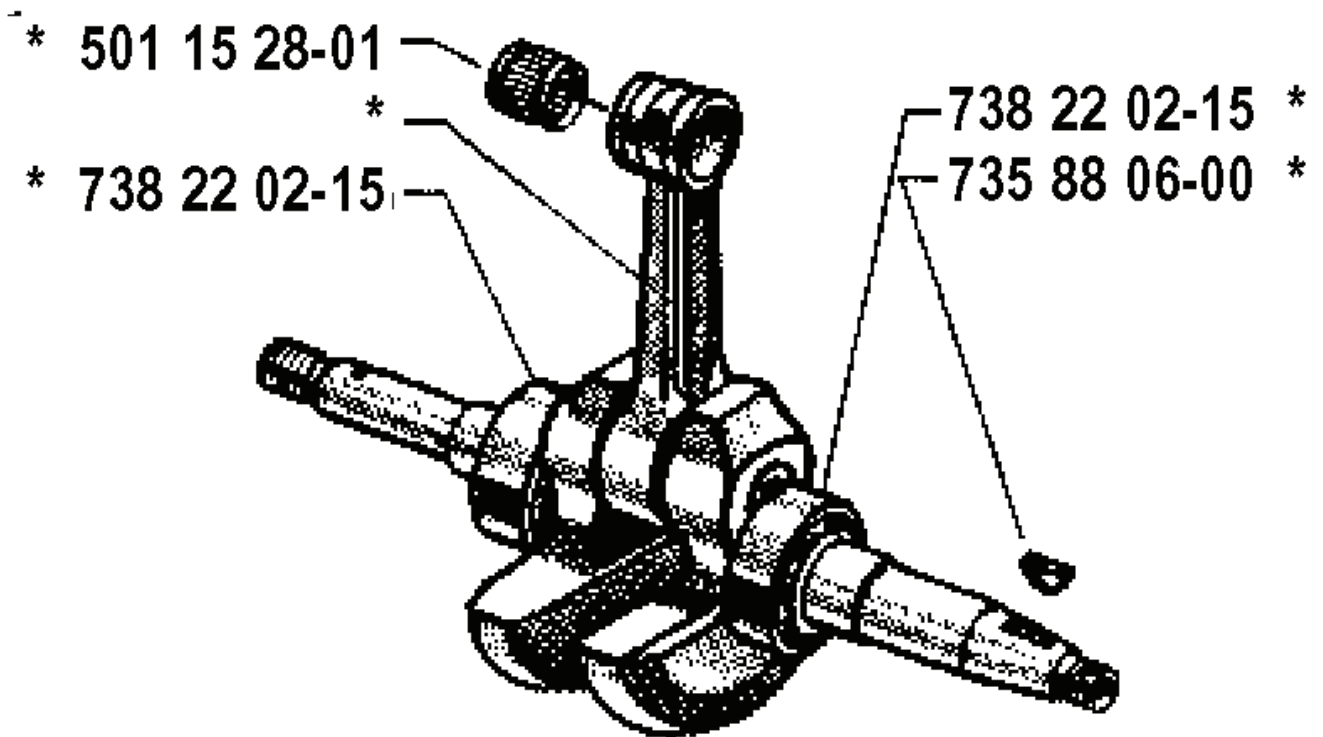

REF.	PART NO.	DESCRIPTION	REMARK	QTY.	KIT
5015561-01	501556101	CRANKSHAFT ASSY		1	
5011528-01	501152801	NEEDLE BEARING		1	
7358806-00	735880600	WOODRUFF KEY		1	
7382202-15	738220215	BALL BEARING		1	