

5 SAW ATTACHMENT, 20042300001-20062

SPARE PARTS LIST

C

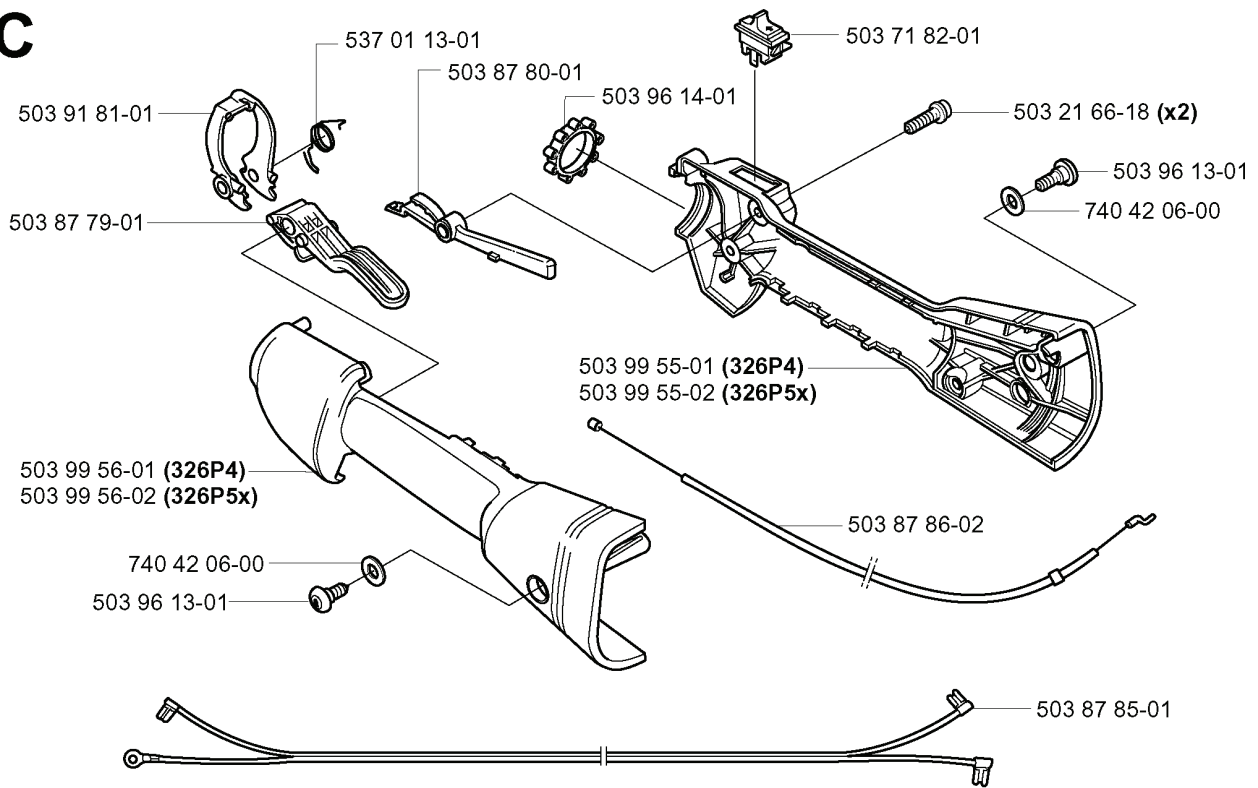

REF.	PART NO.	DESCRIPTION	REMARK	QTY.	KIT
5039181-01	503918101	THROTTLE LEVER		1	
5038779-01	503877901	THROTTLE TRIGGER		1	
5039956-01	503995601	HANDLE HALF	326P4	1	
5039956-02	503995602	HANDLE HALF	326P5X	1	
5039613-01	503961301	SCREW		1	
5038785-01	503878501	SHORT CIRCUIT CABLE		1	
5038786-02	503878602	THROTTLE CABLE ASSY		1	
5039955-02	503995502	HANDLE HALF	326P5X	1	
5039955-01	503995501	HANDLE HALF	326P4	1	
5039614-01	503961401	ABSORBER		1	
5038780-01	503878001	THROTTLE LOCKOUT		1	
5370113-01	537011301	RECOIL SPRING		1	
5037182-01	503718201	SWITCH		1	
7404206-00	740420600	O-RING		1	
5032166-18	503216618	SCREW IH SCT		2	

D

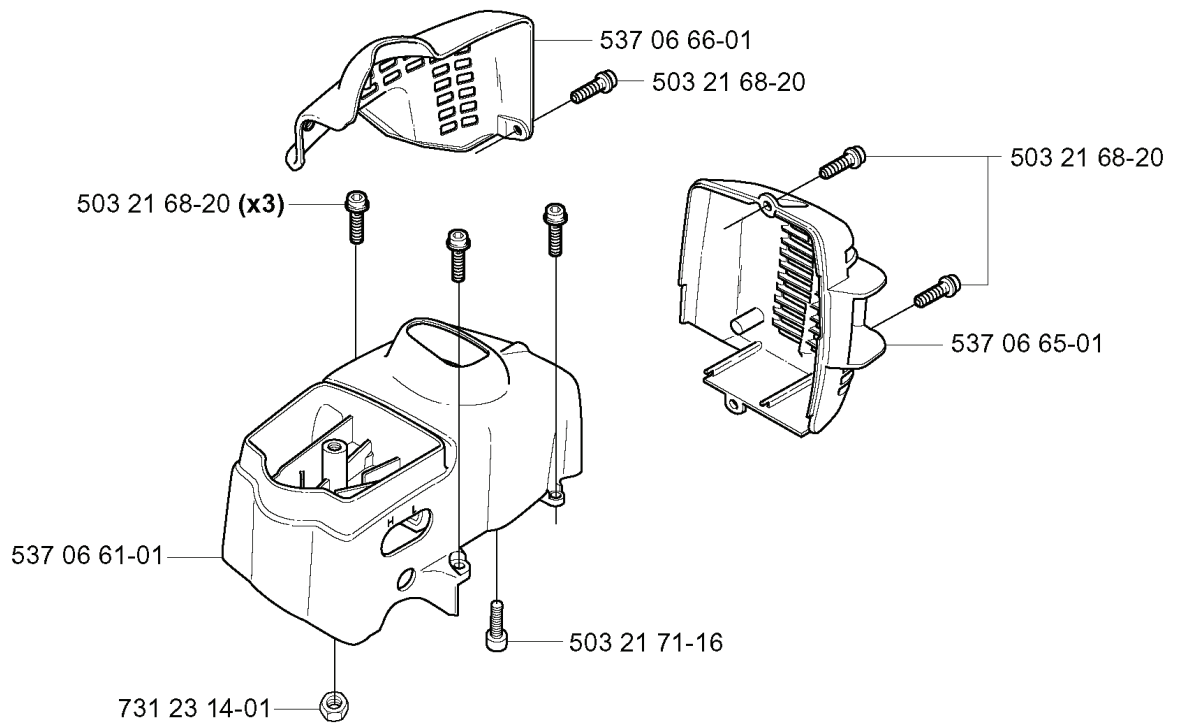

REF.	PART NO.	DESCRIPTION	REMARK	QTY.	KIT
537 06 61-01	537066101	CYLINDER COVER		1	
731 23 14-01	731231401	HEXAGON NUT		1	
503 21 71-16	503217116	SCREW IHSC T		1	
537 06 65-01	537066501	HEAT PROTECTOR		1	
503 21 68-20	503216820	SCREW IHSC FT		1	
537 06 66-01	537066601	ARM PROTECTION		1	

H

* compl 537 04 23-01

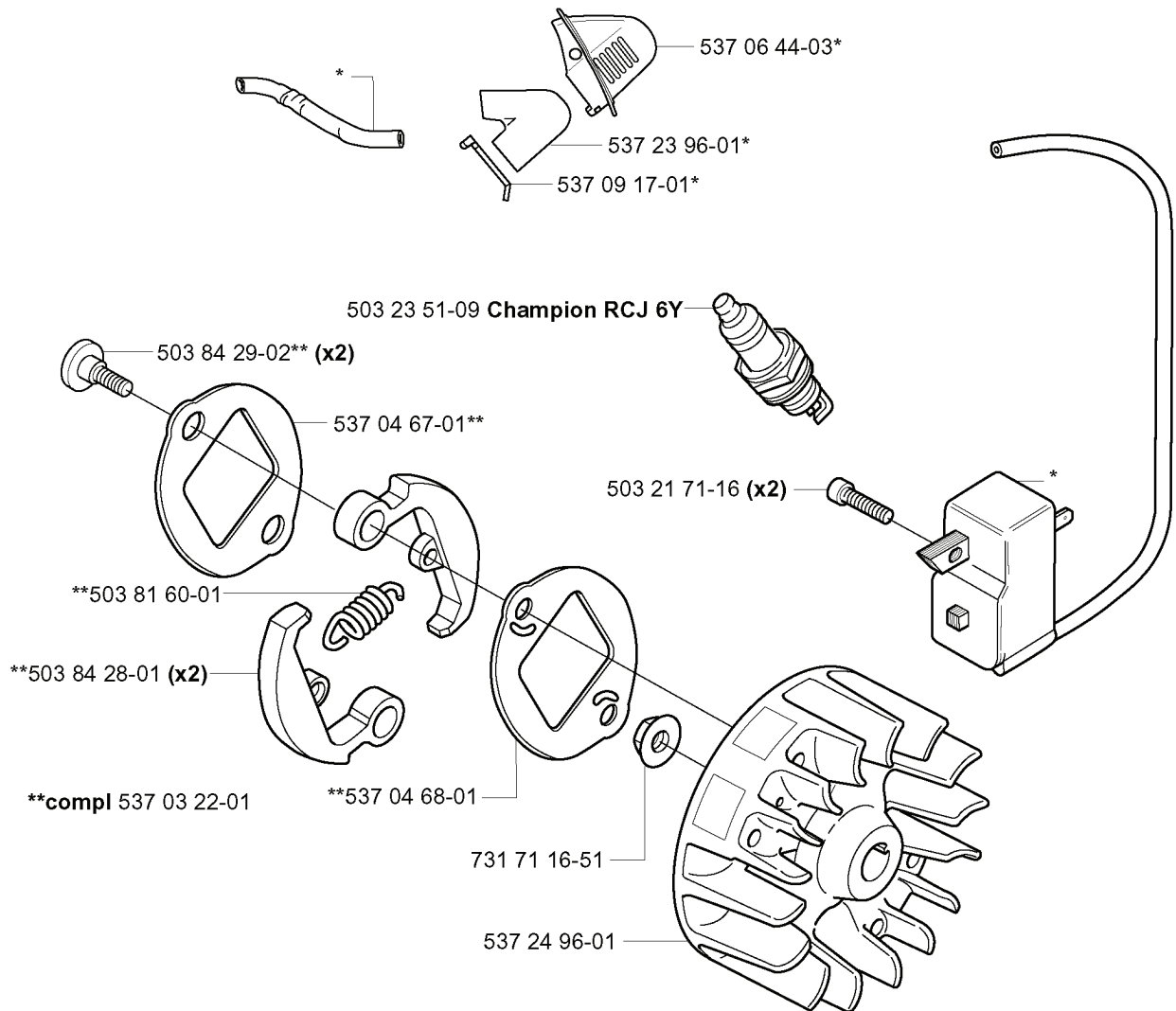

REF.	PART NO.	DESCRIPTION	REMARK	QTY.	KIT
537 04 23-01	537042301	IGNITION MODULE		1	
537 06 44-03	537064403	COVER		1	
537 23 96-01	537239601	SPARK PLUG CAP		1	
537 09 17-01	537091701	SECURING PLATE		1	
503 23 51-09	503235109	SPARK PLUG	CHAMPION RCJ 6Y	1	
503 84 29-02	503842902	SCREW		2	
537 04 67-01	537046701	WASHER		1	
503 81 60-01	503816001	CLUTCH SPRING		1	
503 84 28-01	503842801	CLUTCH SHOE		2	
537 03 22-01	537032201	CLUTCH ASSY		1	
537 04 68-01	537046801	WASHER		1	
731 71 16-51	731711651	HEXAGON NUT FLANGE		1	
537 24 96-01	537249601	FLYWHEEL		1	
503 21 71-16	503217116	SCREW IHSCT		2	

REF.	PART NO.	DESCRIPTION	REMARK	QTY.	KIT
503 28 31-11	503283111	CARBURETTOR		1	
537 02 09-01	537020901	SHAFT ASSY		1	
503 48 19-01	503481901	COLLAR		1	
537 04 90-01	537049001	LEVER		1	
537 02 10-01	537021001	SPRING		1	
537 02 11-01	537021101	VALVE		1	
503 48 18-01	503481801	SCREW		1	
503 47 90-01	503479001	SCREW		1	
537 01 98-01	537019801	LEVER		1	
503 47 89-01	503478901	COLLAR		1	
537 01 26-01	537012601	SPRING		1	
537 01 25-01	537012501	BALL		1	
503 53 57-01	503535701	STRAINER	531 00 45-53 REPAIRKIT	1	
537 02 00-01	537020001	DIAPHRAGM PUMP	531 00 45-52 SET OF GASKETS 531 00 45-53 REPAIRKIT	1	
537 02 01-01	537020101	GASKET	531 00 45-52 SET OF GASKETS 531 00 45-53 REPAIRKIT	1	
537 02 02-01	537020201	COVER		1	
503 47 96-01	503479601	SCREW		1	
537 02 07-01	537020701	SCREW		1	
503 48 11-01	503481101	PIECE		1	
503 47 92-01	503479201	SCREW		1	
537 01 96-01	537019601	SHAFT ASSY		1	
537 01 99-01	537019901	VALVE		1	
537 01 97-01	537019701	SPRING		1	
503 75 53-01	503755301	SCREW		1	
537 02 06-01	537020601	SCREW		1	
537 02 16-01	537021601	LIMITER CAP		1	
537 12 78-01	537127801	SCREW		1	
503 97 40-01	503974001	WASHER		1	
503 48 08-01	503480801	SPRING		1	
537 02 08-01	537020801	PLUG	531 00 45-53 REPAIRKIT	1	
503 47 97-01	503479701	VALVE	531 00 45-53 REPAIRKIT	1	
537 02 03-01	537020301	SPRING	531 00 45-53 REPAIRKIT	1	
503 66 59-01	503665901	LEVER	531 00 45-53 REPAIRKIT	1	
503 48 00-01	503480001	PIN RETAINING SCREW	531 00 45-53 REPAIRKIT	1	
503 48 01-01	503480101	SCREW		1	
537 02 04-01	537020401	GASKET	531 00 45-52 SET OF GASKETS 531 00 45-53 REPAIRKIT	1	
537 04 89-01	537048901	DIAPHRAGM	531 00 45-52 SET OF GASKETS 531 00 45-53 REPAIRKIT	1	
503 97 43-01	503974301	COVER		1	
503 48 05-01	503480501	SCREW		2	

P Saw Attachment
compl 537 18 33-11
compl 537 18 33-12 (USA)

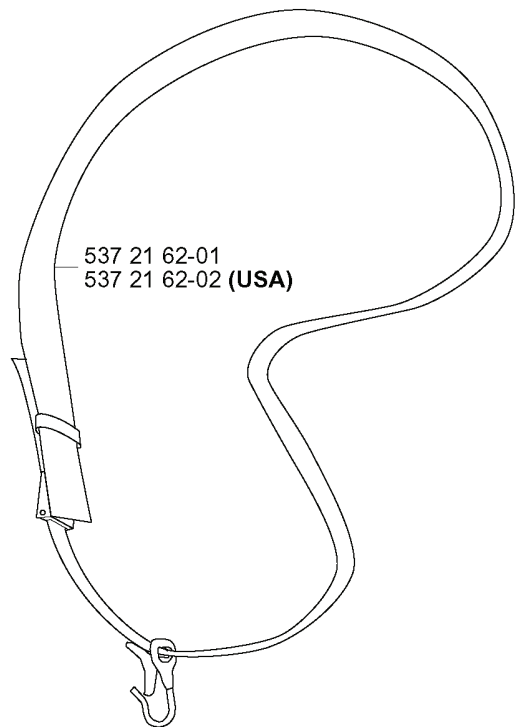
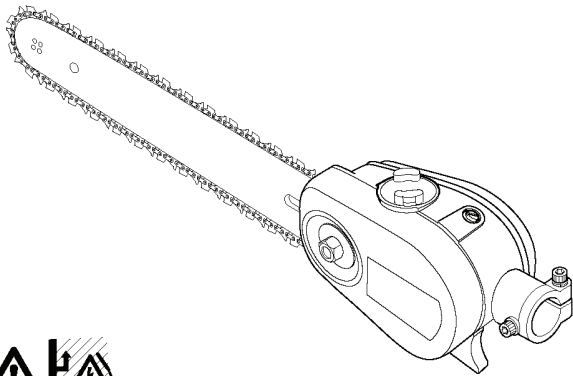

537 38 89-01*

*503 21 83-16

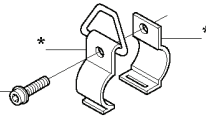

*compl 501 78 33-01

REF.	PART NO.	DESCRIPTION	REMARK	QTY.	KIT
537 18 33-11	537183311	ATTACHMENT		1	
537 18 33-12	537183312	ATTACHMENT	USA	1	
537 38 89-01	537388901	LABEL		1	
503 21 83-16	503218316	SCREW		1	
501 78 33-01	501783301	SUSPENSION BAIL		1	
537 21 62-02	537216202	HARNESS	USA	1	
537 21 62-01	537216201	HARNESS		1	

P Saw Attachment L=110mm
compl 537 18 33-13

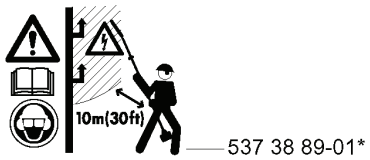
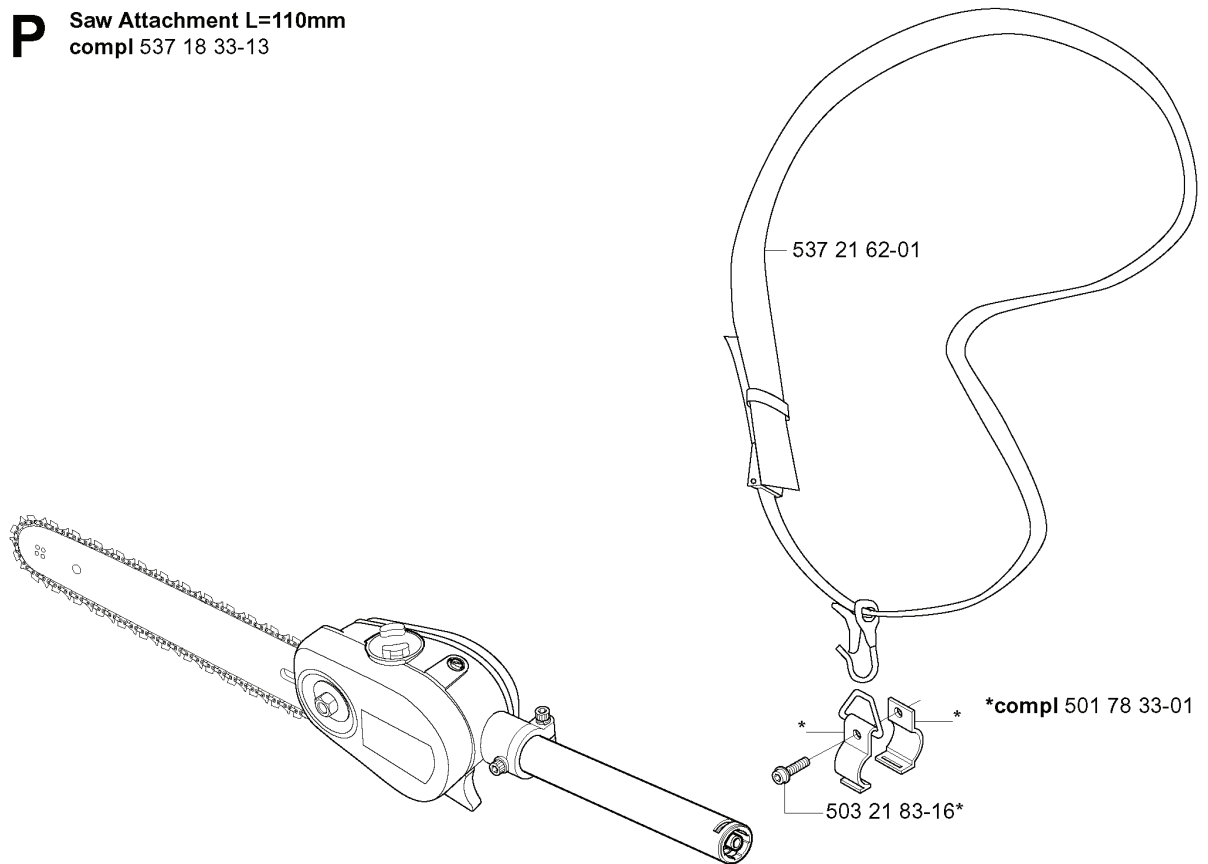

REF.	PART NO.	DESCRIPTION	REMARK	QTY.	KIT
537 18 33-13	537183313	ATTACHMENT		1	
537 38 89-01	537388901	LABEL		1	
503 21 83-16	503218316	SCREW		1	
501 78 33-01	501783301	SUSPENSION BAIL		1	
537 21 62-01	537216201	HARNESS		1	

B 326P5x

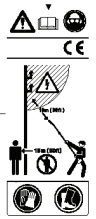
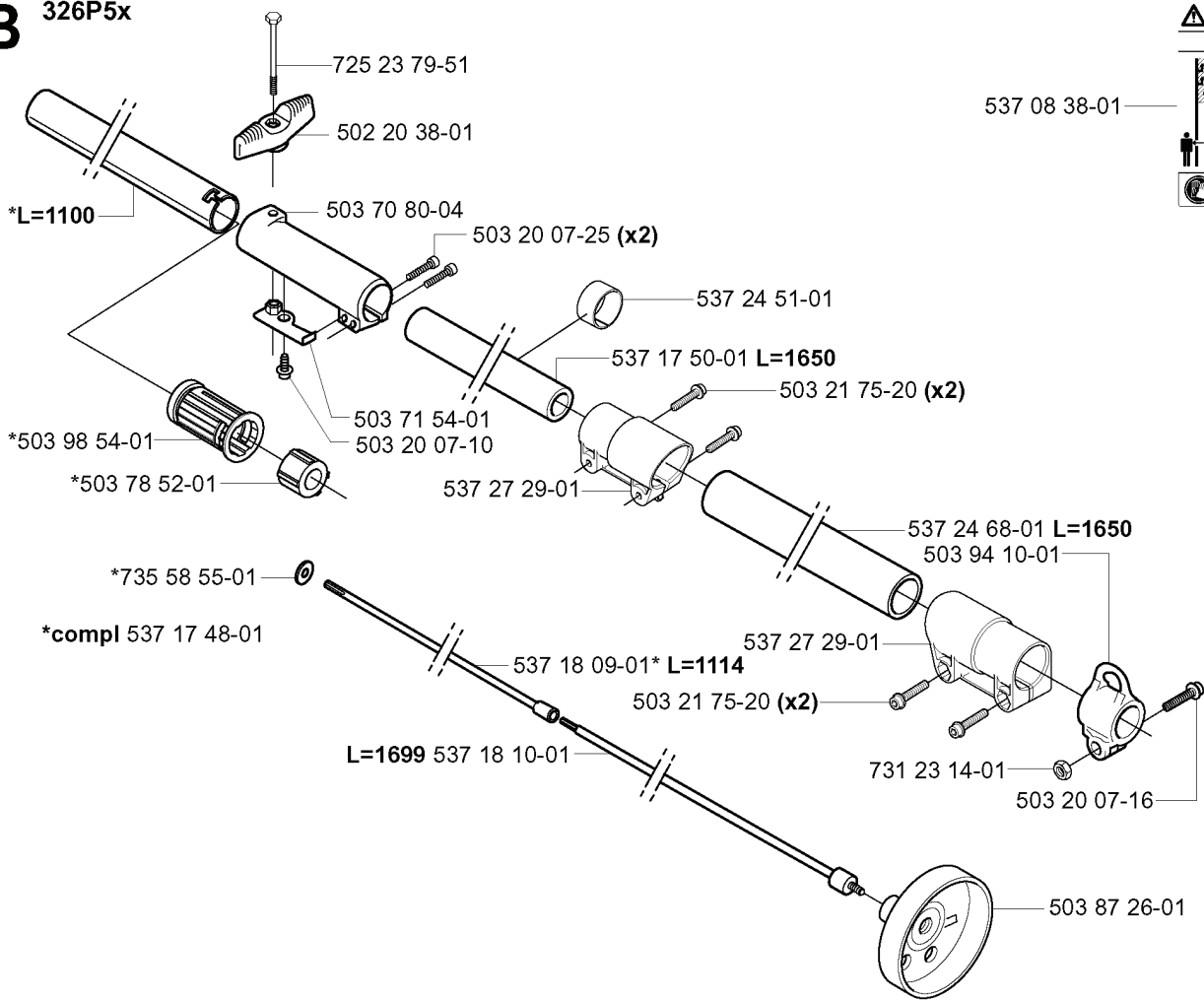

537 08 38-01

REF.	PART NO.	DESCRIPTION	REMARK	QTY.	KIT
5039854-01	503985401	BEARING CAGE		1	
5037852-01	503785201	SUPPORTING BEARING		1	
7355855-01	735585501	WASHER		1	
5371748-01	537174801	TUBE		1	
5371810-01	537181001	DRIVE SHAFT	L=1699	1	
5371809-01	537180901	DRIVE SHAFT	L=1114	1	
5372729-01	537272901	COMPRESSION SLEEVE		1	
5032007-10	503200710	SCREW IHSCFM		1	
5037154-01	503715401	LOCKING PLATE		1	
5037080-04	503708004	SLEEVE		1	
5022038-01	502203801	KNOB		1	
7252379-51	725237951	SCREW EHHM		1	
5032007-25	503200725	SCREW IHSCFM		2	
5372451-01	537245101	SPACER		1	
5371750-01	537175001	TUBE	L=1650	1	
5032175-20	503217520	SCREW IHSCFT		2	
5038726-01	503872601	CLUTCH DRUM ASSY		1	
5032007-16	503200716	SCREW IHSCFM		1	
7312314-01	731231401	HEXAGON NUT		1	
5039410-01	503941001	HOOK		1	
5372468-01	537246801	PIPE	L=1650	1	
5370838-01	537083801	LABEL		1	

REF.	PART NO.	DESCRIPTION	REMARK	QTY.	KIT
5370686-02	537068602	FUEL TANK		1	
5039366-01	503936601	PURGE		1	
5370424-01	537042401	FUEL HOSE		1	
5037358-01	503735801	BUSHING		2	
5039110-01	503911001	SUSPENSION		4	
5034432-01	503443201	FUEL FILTER		1	
5035776-01	503577601	FUEL HOSE		1	
5371849-01	537184901	O-RING		1	
5039118-02	503911802	TANK CAP		1	



*compl 503 85 24-74

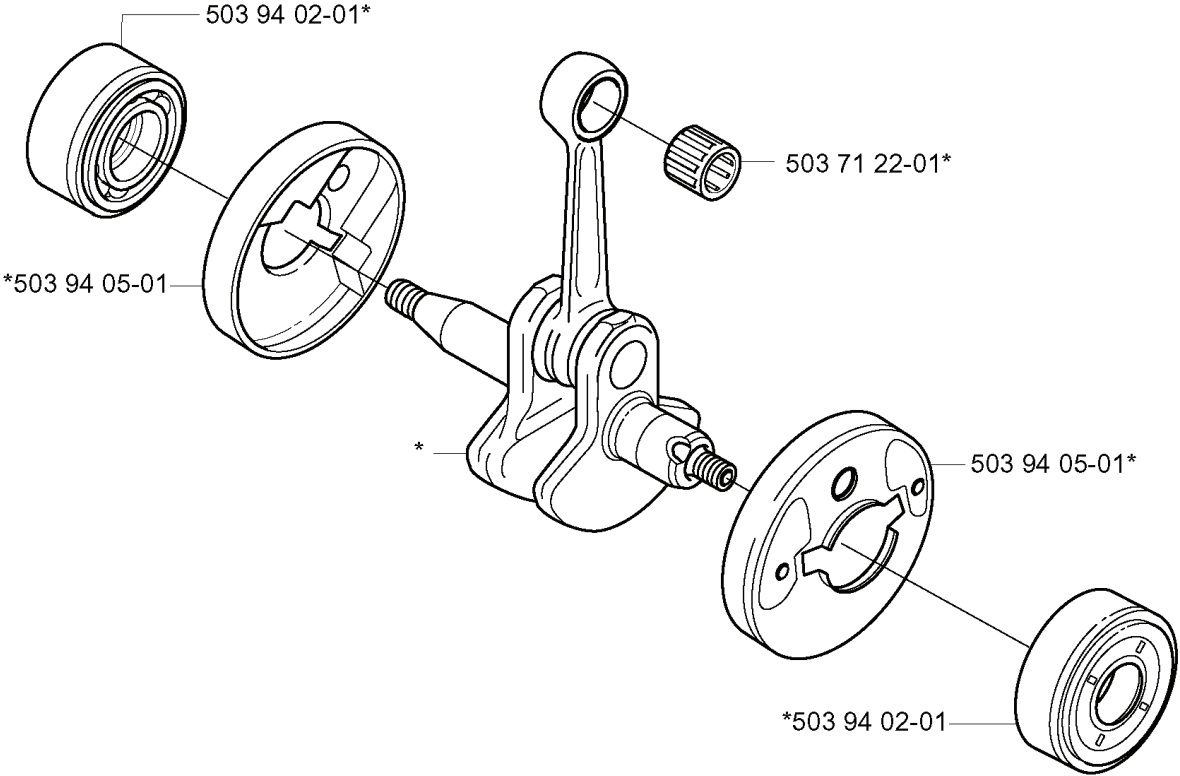

REF.	PART NO.	DESCRIPTION	REMARK	QTY.	KIT
503 85 24-74	503852474	CRANKSHAFT ASSY		1	
503 94 02-01	503940201	BEARING CAGE		1	
503 94 05-01	503940501	CUP		1	
503 71 22-01	503712201	BEARING		1	

E

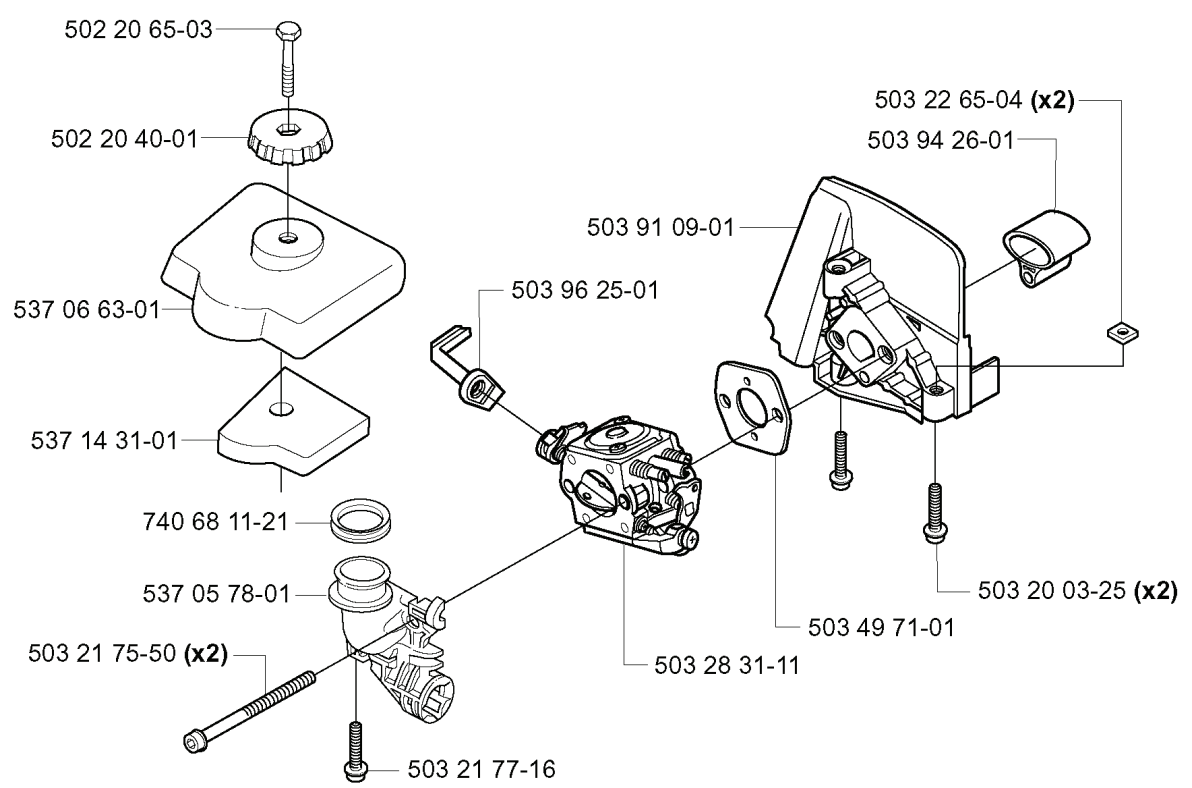

REF.	PART NO.	DESCRIPTION	REMARK	QTY.	KIT
502 20 65-03	502206503	SCREW EHHM		1	
502 20 40-01	502204001	KNOB		1	
537 06 63-01	537066301	FILTER COVER		1	
537 14 31-01	537143101	AIR FILTER ASSY		1	
740 68 11-21	740681121	V-RING		1	
537 05 78-01	537057801	BRACKET		1	
503 21 75-50	503217550	SCREW IHSCFT		2	
503 21 77-16	503217716	SCREW IHSCFT		1	
503 28 31-11	503283111	CARBURETTOR		1	
503 49 71-01	503497101	GASKET		1	
503 20 03-25	503200325	SCREW IHSCFM		2	
503 96 25-01	503962501	CHOKE CONTROL		1	
503 91 09-01	503910901	INSULATION WALL		1	
503 94 26-01	503942601	INLET PIPE		1	
503 22 65-04	503226504	SQUARE NUT		2	

B Saw Attachment
*compl 537 19 58-01

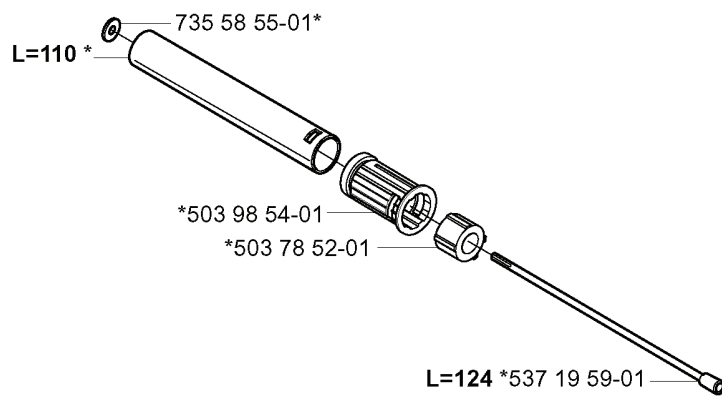

537 19 84-01



REF.	PART NO.	DESCRIPTION	REMARK	QTY.	KIT
537 19 58-01	537195801	TUBE		1	
735 58 55-01	735585501	WASHER	L=1100	1	
503 98 54-01	503985401	BEARING CAGE		1	
503 78 52-01	503785201	SUPPORTING BEARING		1	
537 19 59-01	537195901	DRIVE SHAFT		1	
537 19 84-01	537198401	LABEL		1	

P Saw Attachment L=1100mm
compl 537 18 33-16
compl 537 18 33-17 (USA)

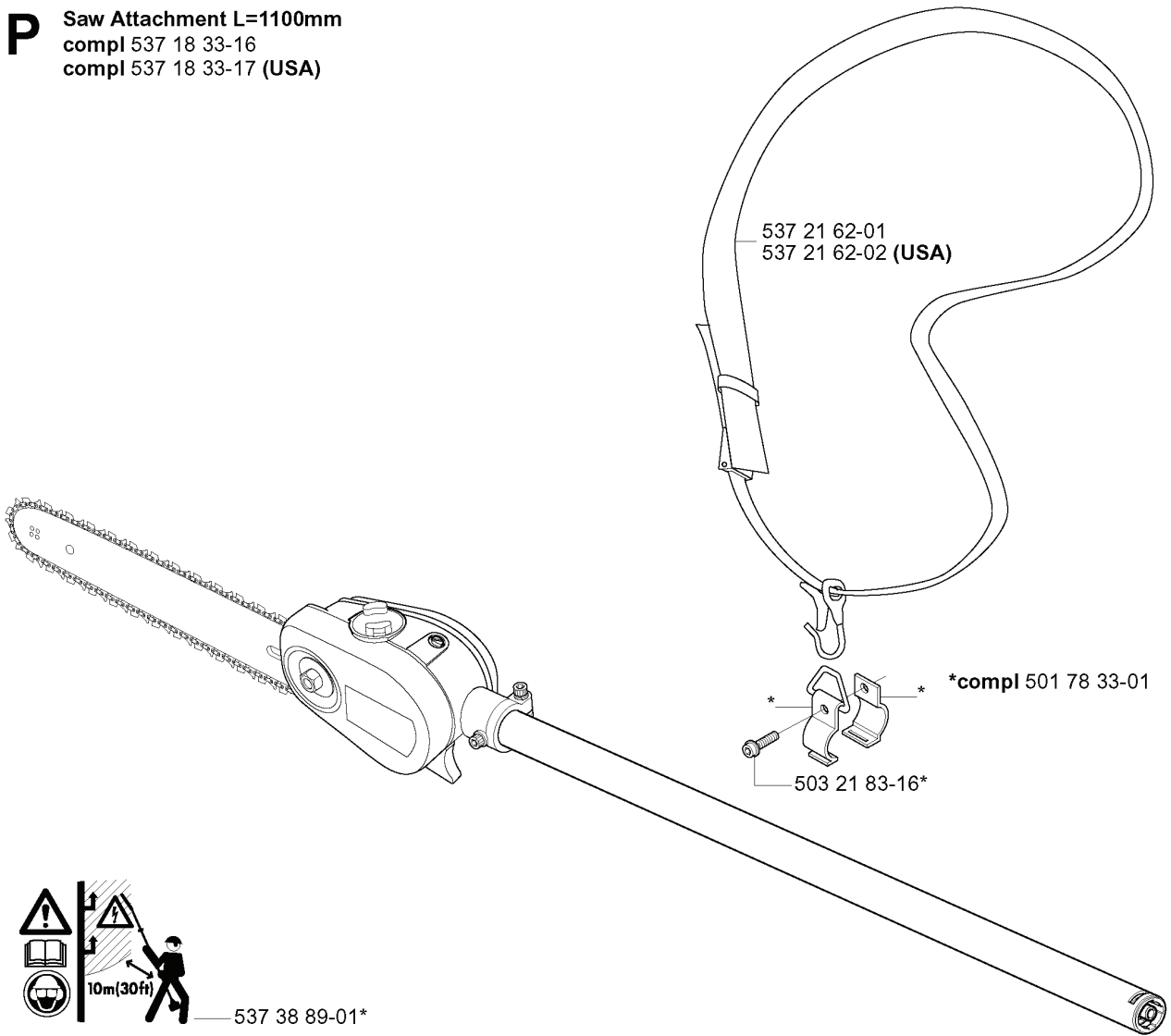

REF.	PART NO.	DESCRIPTION	REMARK	QTY.	KIT
537 18 33-16	537183316	ATTACHMENT		1	
537 18 33-17	537183317	ATTACHMENT	USA	1	
537 38 89-01	537388901	LABEL		1	
503 21 83-16	503218316	SCREW		1	
501 78 33-01	501783301	SUSPENSION BAIL		1	
537 21 62-02	537216202	HARNESS	USA	1	
537 21 62-01	537216201	HARNESS		1	

B Saw Attachment

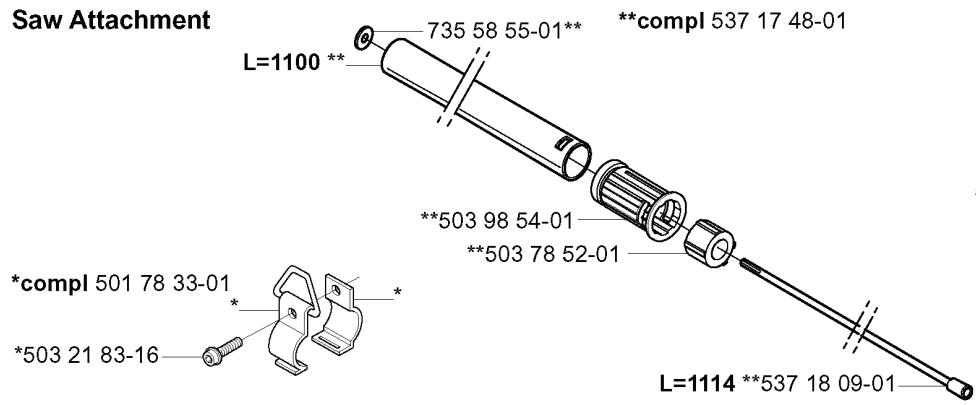

REF.	PART NO.	DESCRIPTION	REMARK	QTY.	KIT
735 58 55-01	735585501	WASHER		1	
501 78 33-01	501783301	SUSPENSION BAIL		1	
503 21 83-16	503218316	SCREW		1	
537 18 09-01	537180901	DRIVE SHAFT		1	
503 78 52-01	503785201	SUPPORTING BEARING		1	
503 98 54-01	503985401	BEARING CAGE		1	
537 19 84-01	537198401	LABEL		1	
537 17 48-01	537174801	TUBE		1	

M Accessories
Zubehöre
Accessoires
Acessorios
Tillbehör

*compl 537 04 07-10

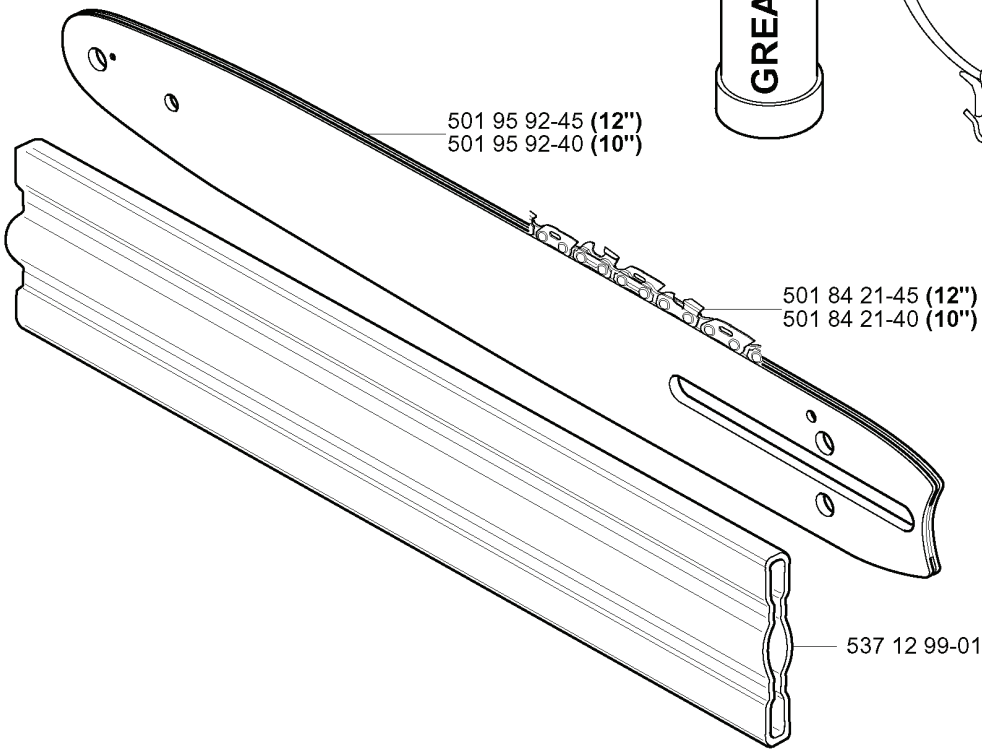
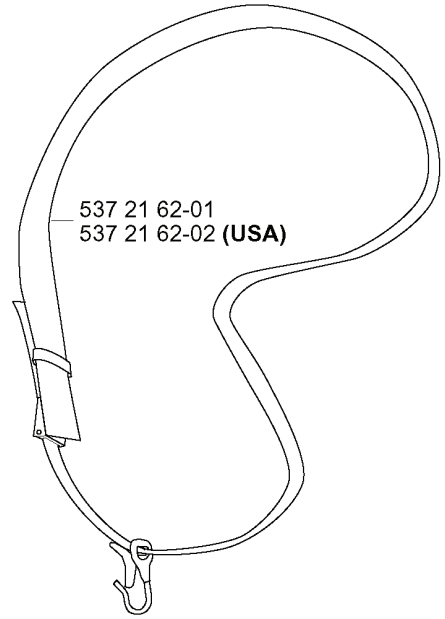
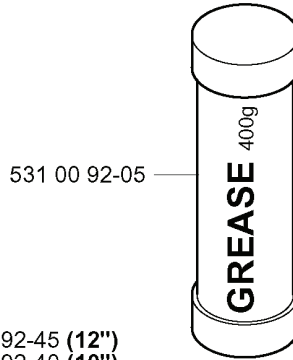
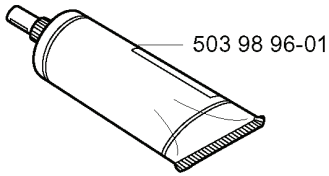
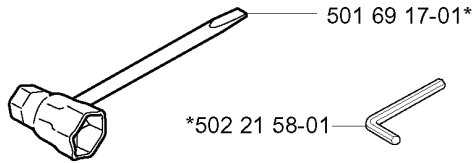

REF.	PART NO.	DESCRIPTION	REMARK	QTY.	KIT
537 04 07-10	537040710	ACCESSORY BAG		1	
501 69 17-01	501691701	COMBINATION WRENCH		1	
502 21 58-01	502215801	WRENCH		1	
503 98 96-01	503989601	GREASE		1	
531 00 92-05	531009205	GREASE		1	
501 95 92-45	501959245	BAR	12	1	
501 95 92-40	501959240	BAR	10	1	
501 84 21-45	501842145	SAW CHAIN	12	1	
501 84 21-40	501842140	SAW CHAIN	10	1	
537 12 99-01	537129901	BAR COVER		1	
537 21 62-02	537216202	HARNESS	USA	1	
537 21 62-01	537216201	HARNESS		1	

REF.	PART NO.	DESCRIPTION	REMARK	QTY.	KIT
537 30 96-01	537309601	SLEEVE		1	
503 21 68-20	503216820	SCREW IHSCFT		3	
503 21 77-16	503217716	SCREW IHSCFT		1	
503 87 26-01	503872601	CLUTCH DRUM ASSY		1	
537 07 36-01	537073601	SPRING		1	
503 21 68-25	503216825	SCREW IHSCFT		2	
537 04 12-03	537041203	CLUTCH COVER		1	
537 06 69-01	537066901	GASKET		1	
537 08 85-01	537088501	GASKET		1	
503 21 66-18	503216618	SCREW IHSCFT		2	
537 06 68-01	537066801	INSERT CRANKCASE		1	
537 08 52-01	537085201	CRANKCASE		1	

F

**compl 503 87 33-02

*compl 503 85 28-01

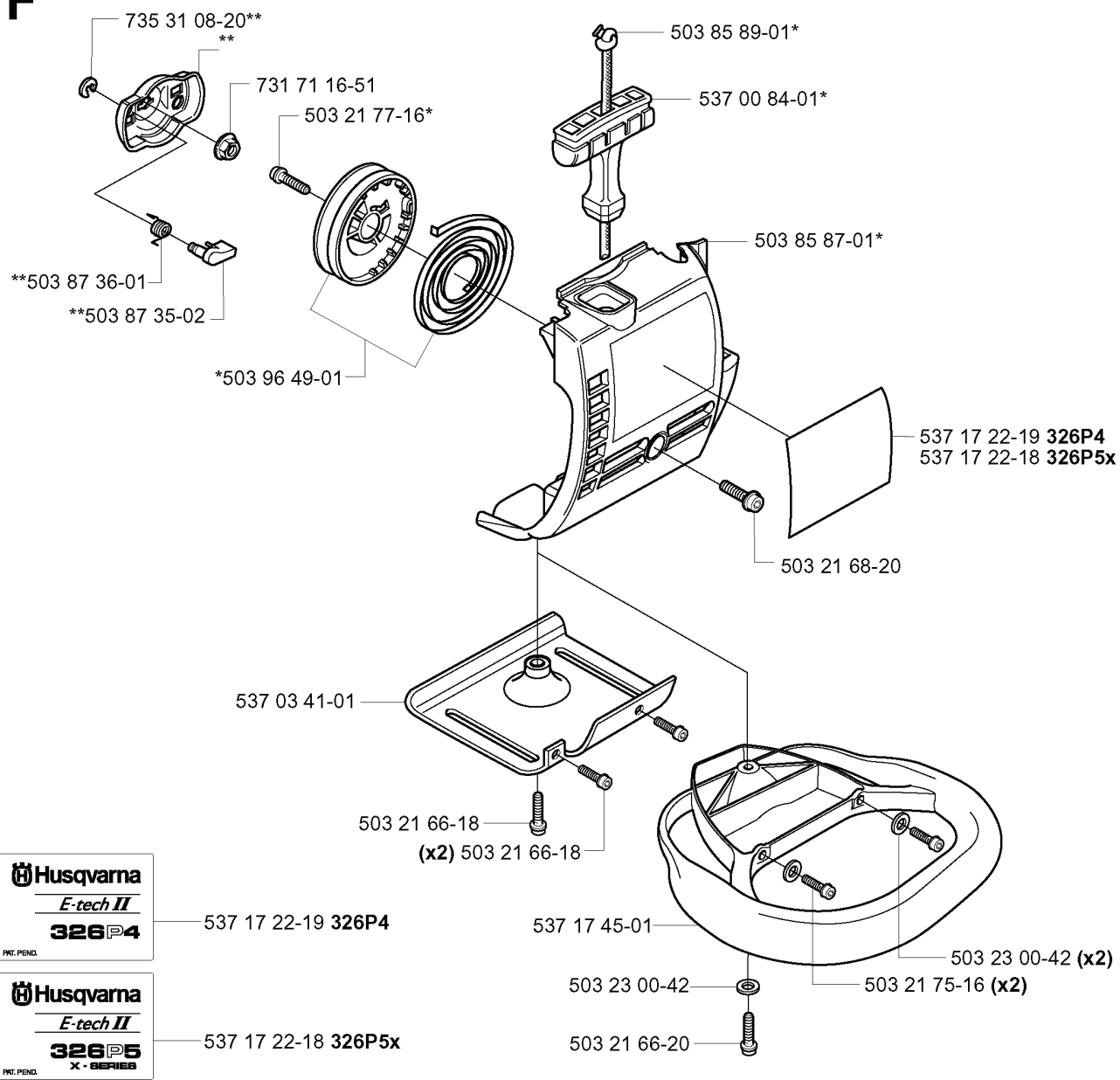

REF.	PART NO.	DESCRIPTION	REMARK	QTY.	KIT
503 87 33-02	503873302	BRIDGE		1	
735 31 08-20	735310820	E-CLIP		1	
731 71 16-51	731711651	HEXAGON NUT FLANGE		1	
503 21 77-16	503217716	SCREW IHSC T		1	
503 87 36-01	503873601	SPRING		1	
503 87 35-02	503873502	STARTER PAWL		1	
503 96 49-01	503964901	STARTER PULLEY		1	
537 03 41-01	537034101	PROTECTIVE PLATE		1	
503 21 66-18	503216618	SCREW IHSC T		2	
537 17 22-19	537172219	LABEL	326P4	1	
537 17 22-18	537172218	LABEL	326P5X	1	
503 21 66-20	503216620	SCREW IHSC T		1	
503 23 00-42	503230042	WASHER		1	
537 17 45-01	537174501	HANDLE		1	
503 21 75-16	503217516	SCREW IHSC FT		2	
503 21 68-20	503216820	SCREW IHSC FT		1	
503 85 87-01	503858701	STARTER HOUSING		1	
537 00 84-01	537008401	STARTER HANDLE		1	
503 85 89-01	503858901	STARTER ROPE		1	
503 85 28-01	503852801	STARTER ASSY		1	

J

****compl 537 08 51-01**

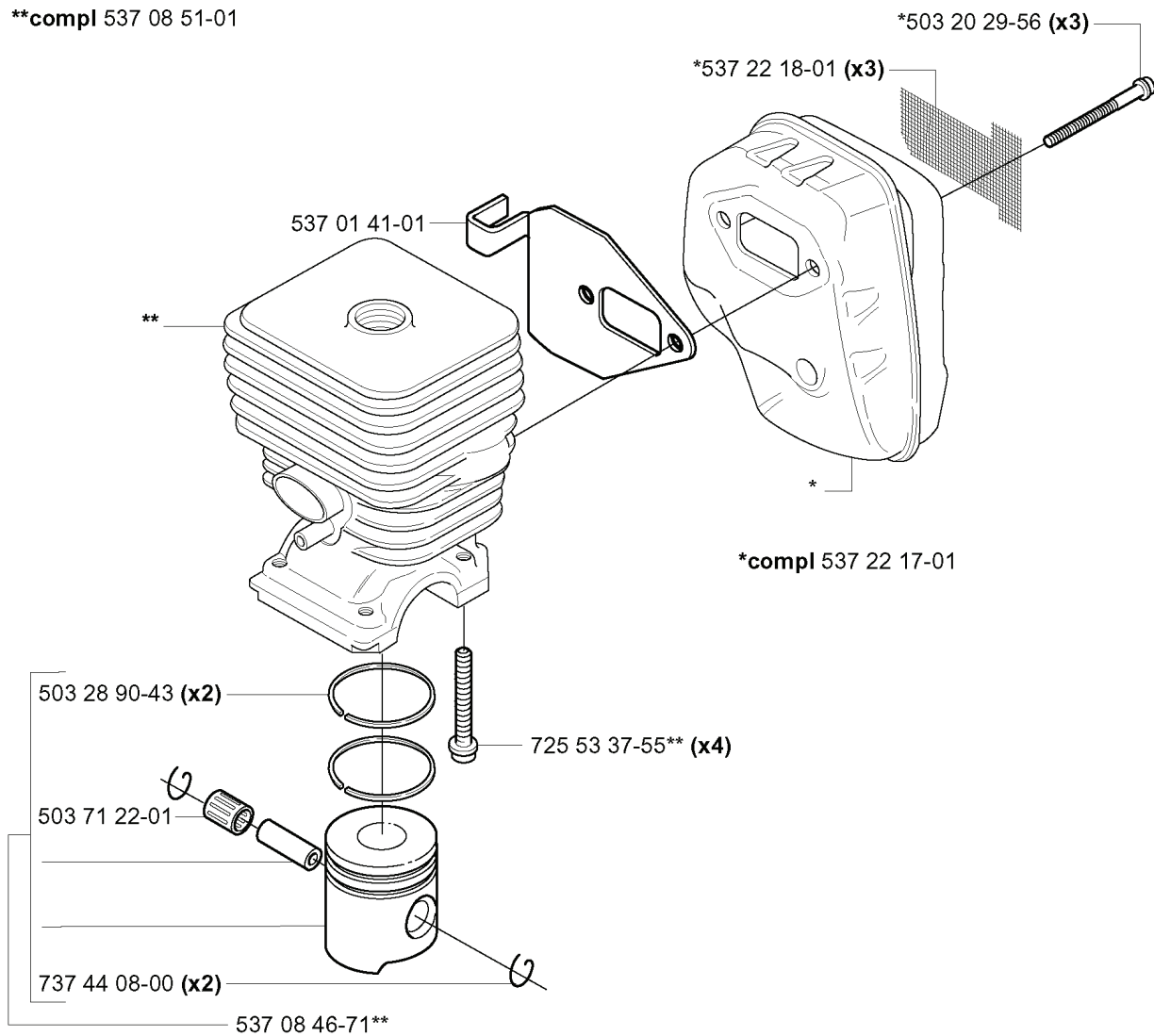

REF.	PART NO.	DESCRIPTION	REMARK	QTY.	KIT
5370851-01	537085101	PISTON		1	
5370141-01	537014101	GASKET		1	
5032890-43	503289043	PISTON RING		2	
5037122-01	503712201	BEARING		1	
7374408-00	737440800	CIRCLIP		2	
5370846-71	537084671	PISTON		1	
7255337-55	725533755	SCREW IHSCM		4	
5372217-01	537221701	MUFFLER ASSY		1	
5372218-01	537221801	SPARK ARRESTER SCREEN		3	
5032029-56	503202956	SCREW IHSCFM		3	

B 326P4

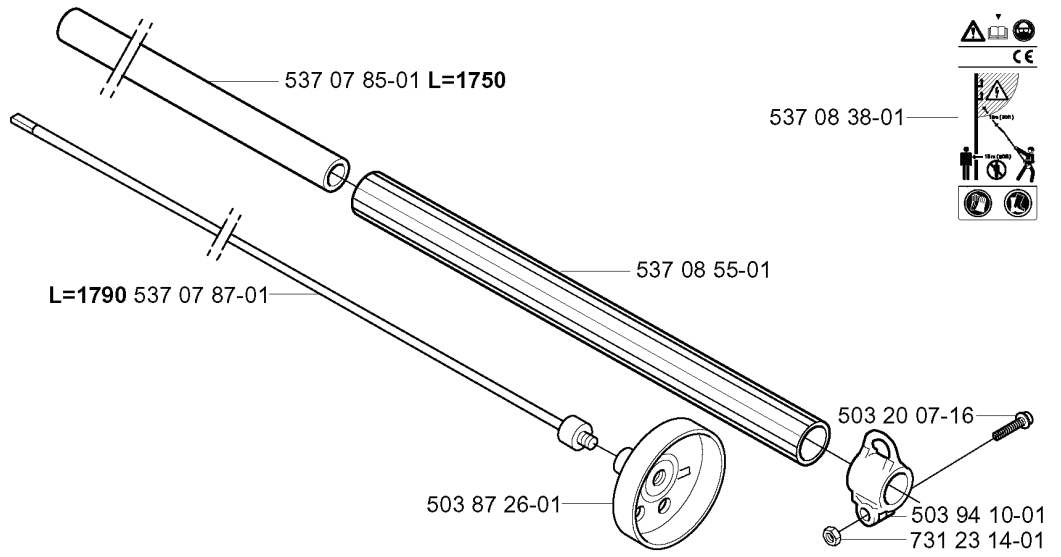

REF.	PART NO.	DESCRIPTION	REMARK	QTY.	KIT
537 07 85-01	537078501	TUBE	L=1750	1	
537 07 87-01	537078701	DRIVE SHAFT	L=1790	1	
503 87 26-01	503872601	CLUTCH DRUM ASSY		1	
731 23 14-01	731231401	HEXAGON NUT		1	
503 94 10-01	503941001	HOOK		1	
503 20 07-16	503200716	SCREW IHSCFM		1	
537 08 55-01	537085501	HANDLE		1	
537 08 38-01	537083801	LABEL		1	

A

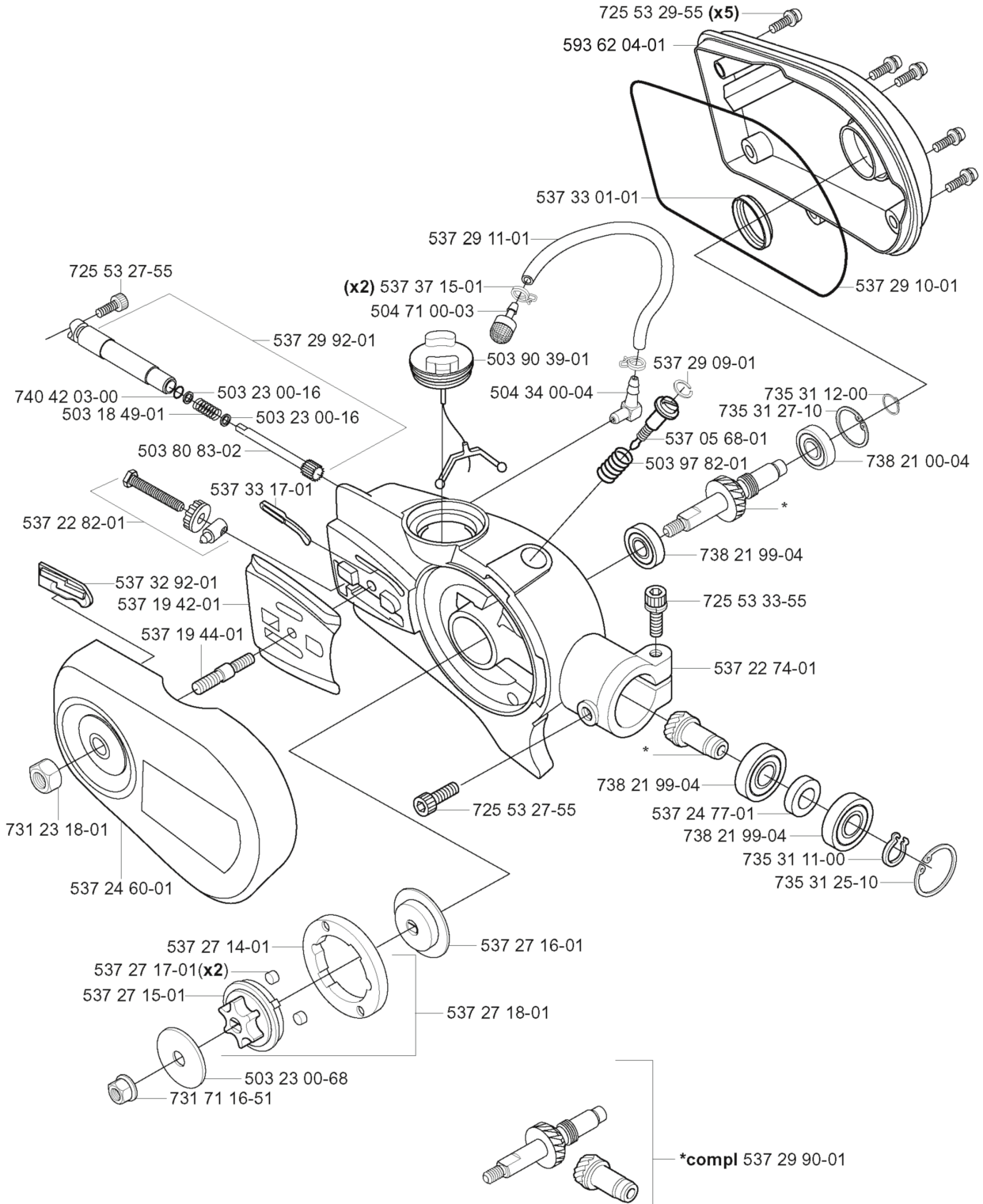

537 23 00-01



REF.	PART NO.	DESCRIPTION	REMARK	QTY.	KIT
725 53 27-55	725532755	SCREW IHSCM		1	
740 42 03-00	740420300	O-RING		1	
503 18 49-01	503184901	SPRING		1	
537 22 82-01	537228201	CHAIN TENSIONER		1	
537 32 92-01	537329201	SEALING		1	
537 19 42-01	537194201	CHAIN GUIDE PLATE		1	
537 19 44-01	537194401	BAR BOLT		1	
731 23 18-01	731231801	HEXAGON NUT		1	
537 24 60-01	537246001	COVER		1	
537 27 14-01	537271401	RING		1	
537 27 17-01	537271701	BUSHING		2	
537 27 15-01	537271501	HUB		1	
731 71 16-51	731711651	HEXAGON NUT FLANGE		1	
503 23 00-68	503230068	WASHER		1	
537 33 17-01	537331701	OIL DUCT		1	
503 80 83-02	503808302	PUMP PISTON		1	
503 23 00-16	503230016	WASHER		1	
537 29 92-01	537299201	OIL PUMP ASSY		1	
504 71 00-03	504710003	OIL PLUMMET		1	
537 37 15-01	537371501	HOSE CLAMP		2	
537 29 11-01	537291101	HOSE		1	
537 33 01-01	537330101	SEALING		1	
593 62 04-01	593620401	CAP ASSY		1	
725 53 29-55	725532955	SCREW IHSCM		5	
503 90 39-01	503903901	TANK		1	
504 34 00-04	504340004	FITTING		1	
537 27 16-01	537271601	HUB CAP		1	
537 27 18-01	537271801	FLYWHEEL		1	
537 23 00-01	537230001	LABEL		1	
537 29 90-01	537299001	GEAR WHEEL KIT		1	
735 31 25-10	735312510	CIRCLIP		1	
735 31 11-00	735311100	CIRCLIP		1	
738 21 99-04	738219904	BALL BEARING		1	
537 24 77-01	537247701	SPACER		1	
537 22 74-01	537227401	HOUSING		1	
725 53 33-55	725533355	SCREW IHSCM		1	
503 97 82-01	503978201	SPRING		1	
537 05 68-01	537056801	ADJUSTER		1	
738 21 00-04	738210004	BALL BEARING		1	
735 31 27-10	735312710	CIRCLIP		1	
735 31 12-00	735311200	CIRCLIP		1	

REF.	PART NO.	DESCRIPTION	REMARK	QTY.	KIT
537 29 09-01	537290901	CIRCLIP		1	
537 29 10-01	537291001	O-RING		1	
537 04 03-01	537040301	VALVE		1	
503 98 13-01	503981301	PLUG		1	