



SPARE PARTS LIST

ENGINES & TRANSMISSIONS

KAWASAKI ENGINES, FX801V-FS00,
2017-09

E0190-B248A

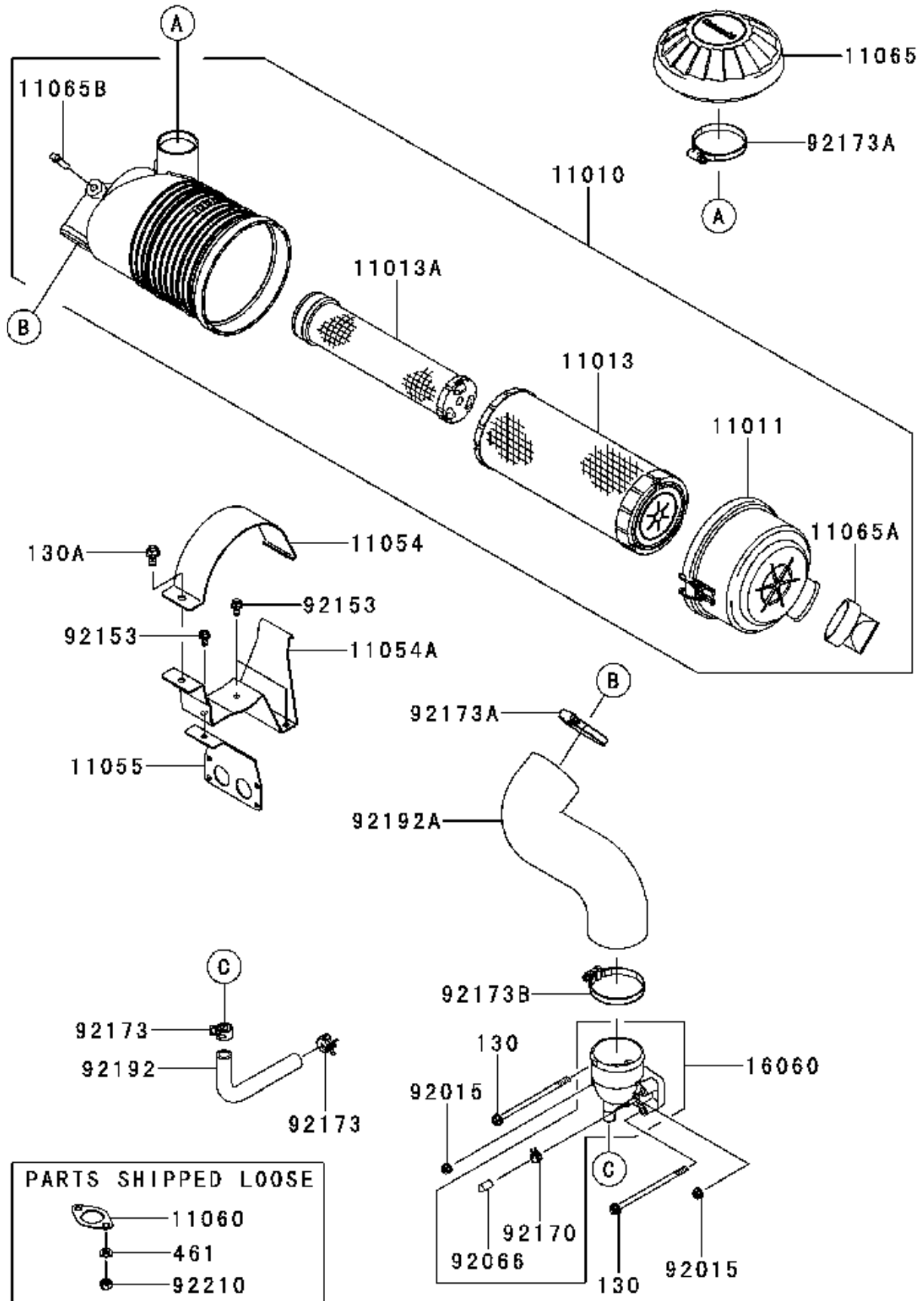

AIR FILTER & MUFFLER

KAWASAKI ENGINES, FX801V-FS00, 2017-09

Ref	Part No	Description	Remark	QTY KIT
11010	577 76 26-01	AIR CLEANER	FILTER-ASSY-AIR	1
11011	579 75 43-01	COVER	CASE-AIR FILTER	1
11013	585 40 80-01	AIR FILTER	ELEMENT-AIR FILTER	1
11013A	585 40 80-02	AIR FILTER	ELEMENT-AIR FILTER	1
11054	577 57 99-01	BRACKET	BRACKET	1
11054A	577 67 89-01	BRACKET	BRACKET	1
11055	577 67 90-01	BRACKET	BRACKET	1
11060	110 60 70-16	GASKET	GASKET	2
11065	577 41 56-01	HUB CAP	CAP	1
11065A	586 51 80-01	CAP	CAP	1
11065B	586 51 81-01	CAP	CAP	1
130	577 58 15-01	BOLT	BOLT-FLANGED,6X120	2
130A	591 45 74-19	BOLT	BOLT-FLANGED	1
16060	591 45 75-41	PIPE	PIPE-INTAKE	1
461	577 58 17-01	WASHER	WASHER-SPRING,8MM	4
92015	577 58 08-01	NUT	NUT,FLANGED,6MM	2
92066	586 51 88-01	PLUG	PLUG	1
92153	577 58 20-01	BOLT	BOLT,6X12	3
92170	586 51 89-01	CLAMP	CLAMP	1
92173	577 58 10-01	CLAMP	CLAMP	2
92173A	580 46 66-01	CLAMP	CLAMP	2
92173B	577 58 11-01	CLAMP	CLAMP	1
92192	577 67 94-01	TUBE	TUBE	1
92192A	591 45 76-25	TUBE	TUBE,AIR-FILTER	1
92210	577 58 14-01	NUT	NUT,M8	4

E0180-B086A

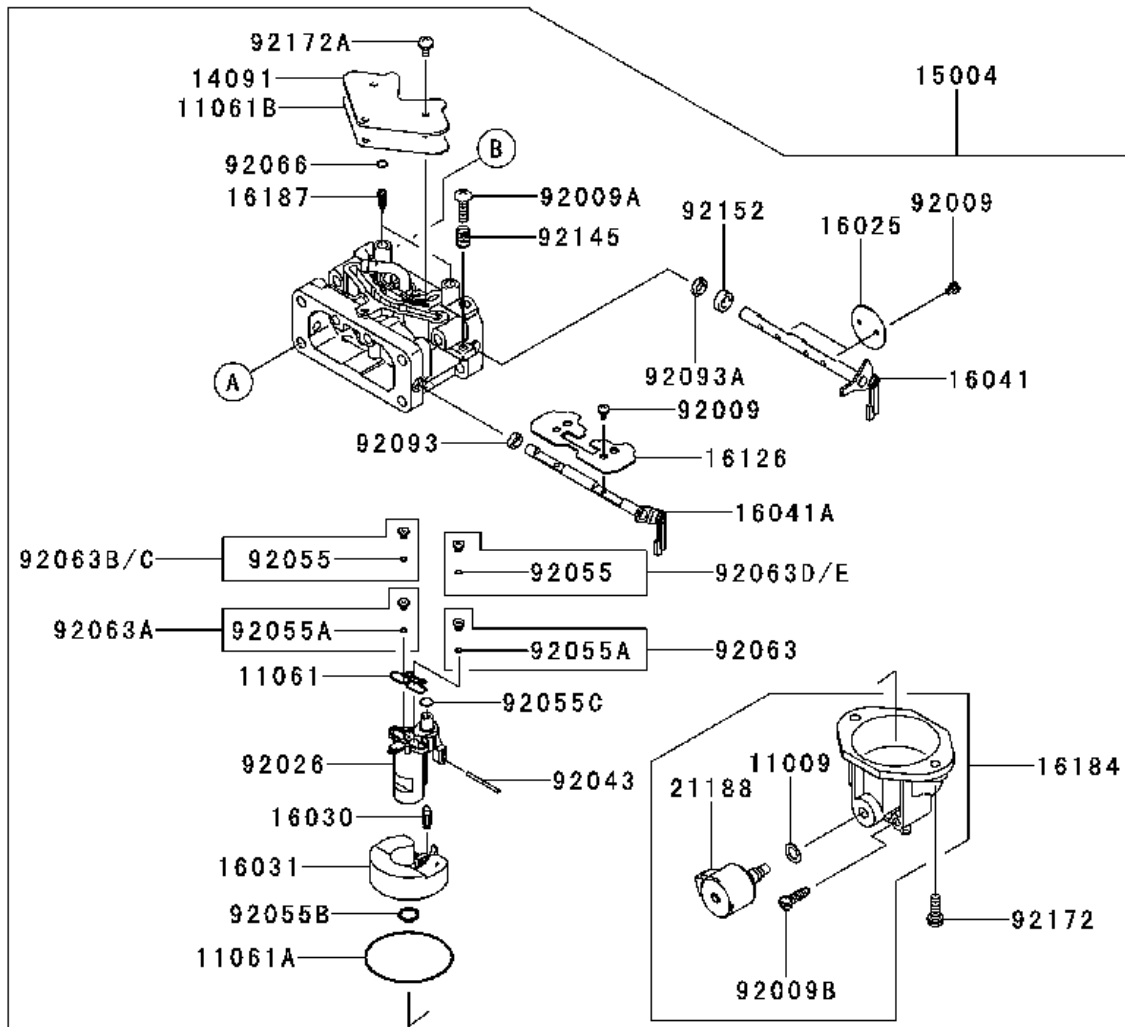
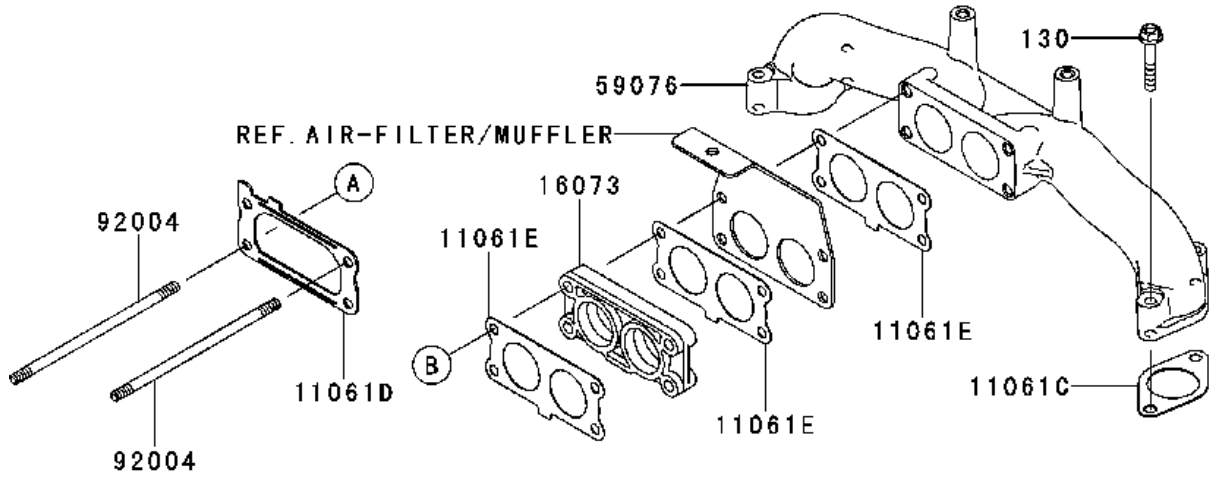

CARBURETOR

KAWASAKI ENGINES, FX801V-FS00, 2017-09

Ref	Part No	Description	Remark	QTY KIT
11009	110 09 20-56	GASKET	GASKET	1
11061	110 61 70-37	GASKET	GASKET	1
11061A	110 61 70-38	GASKET	GASKET	1
11061B	110 61 70-39	GASKET	GASKET	1
11061C	577 67 96-01	GASKET	GASKET,HEAD/MANIFOLD	2
11061D	577 67 99-01	GASKET	GASKET,CARBURETOR/PIP	1
11061E	578 18 07-01	GASKET	GASKET,INSULATOR	3
130	577 57 94-01	BOLT	BOLT-FLANGED	4
14091	140 91 70-31	COVER	COVER	1
15004	592 73 97-23	CARBURETTOR	CARBURETOR-ASSY	1
16025	577 68 01-01	VALVE	VALVE-THROTTLE	2
16030	160 30 70-04	VALVE-FLOAT	VALVE-FLOAT	1
16031	160 31 70-03	FLOAT	FLOAT	1
16041	591 45 75-90	SHAFT	SHAFT-CARBURETOR,THRO	1
16041A	591 45 75-87	SHAFT	SHAFT-CARBURETOR,CHOK	1
16073	577 68 04-01	INSULATOR	INSULATOR	1
16126	577 68 05-01	VALVE	VALVE	1
16184	577 57 76-01	FLOAT	CHAMBER-ASSY-FLOAT	1
16187	577 57 77-01	NEEDLE	NEEDLE-JET	2
21188	211 88 70-03	SOLENOID	SOLENOID	1
59076	592 73 97-44	MANIFOLD	MANIFOLD-INTAKE	1
92004	577 57 78-01	STUD	STUD,6X120	2
92009	577 57 79-01	SCREW	SCREW	6
92009A	578 18 09-01	SCREW	SCREW	1
92009B	586 52 05-01	SCREW	SCREW,DRAIN	1
92026	577 68 07-01	SPACER	SPACER	1
92043	577 57 82-01	PEN	PIN	1
92055	586 52 07-01	O-RING	RING-O	
92055A	586 52 07-01	O-RING	RING-O	2
92055B	920 55 70-16	O-RING	RING-O	1
92055C	577 57 83-01	RING	RING-O	1
92063	591 45 75-09	JET	JET-MAIN,#124	1
92063A	577 68 08-01	JET	JET-MAIN,#118	1
92063B	577 68 10-01	JET	JET-MAIN,#115	
92063C	577 68 11-01	JET	JET-MAIN,#112	
92063D	577 68 12-01	JET	JET-MAIN,#117	
92063E	577 68 13-01	JET	JET-MAIN,#114	
92066	920 66 70-09	PLUG	PLUG,EXPANSION	2
92093	577 57 90-01	SEAL	SEAL,D=5.9	1
92093A	920 93 70-02	SEAL(D=6.9)	SEAL,D=6.9	1
92145	921 45 70-10	SPRING	SPRING	1
92152	577 68 14-01	COLLAR	COLLAR	1
92172	921 72 70-05	SCREW	SCREW	2
92172A	577 57 92-01	SCREW	SCREW	3
Not shown	591 45 74-71	GASKET KIT	CARB GASKET KIT	1

E0170-A764C

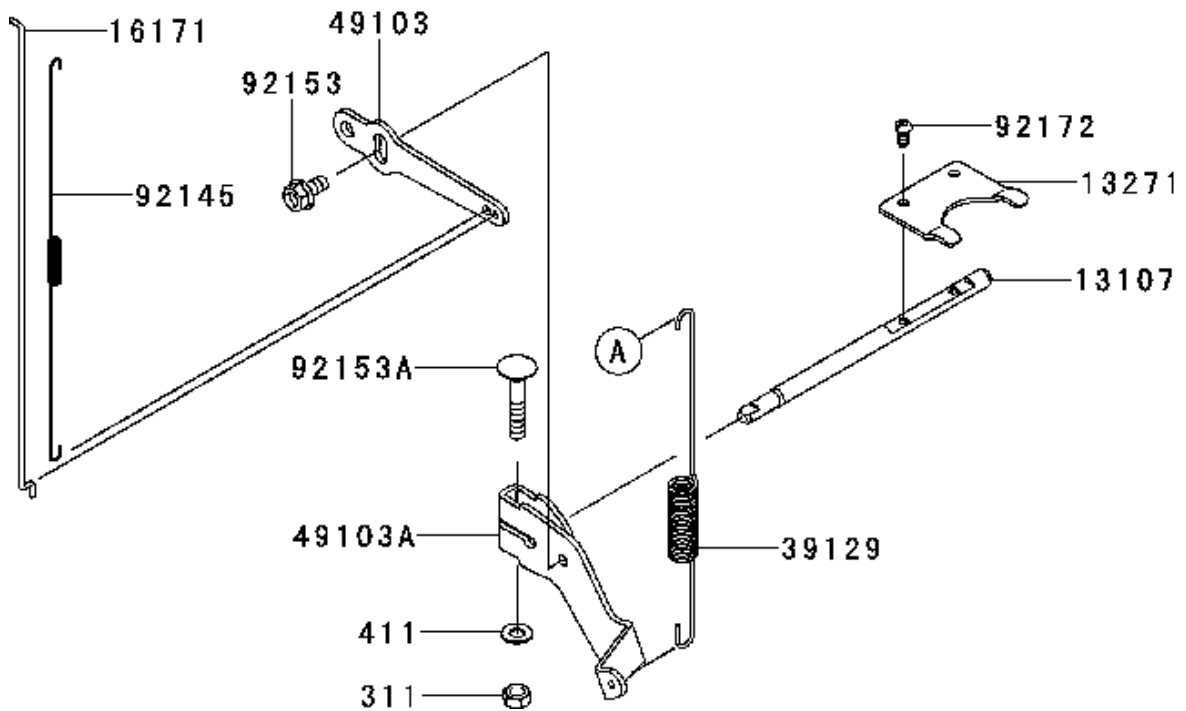
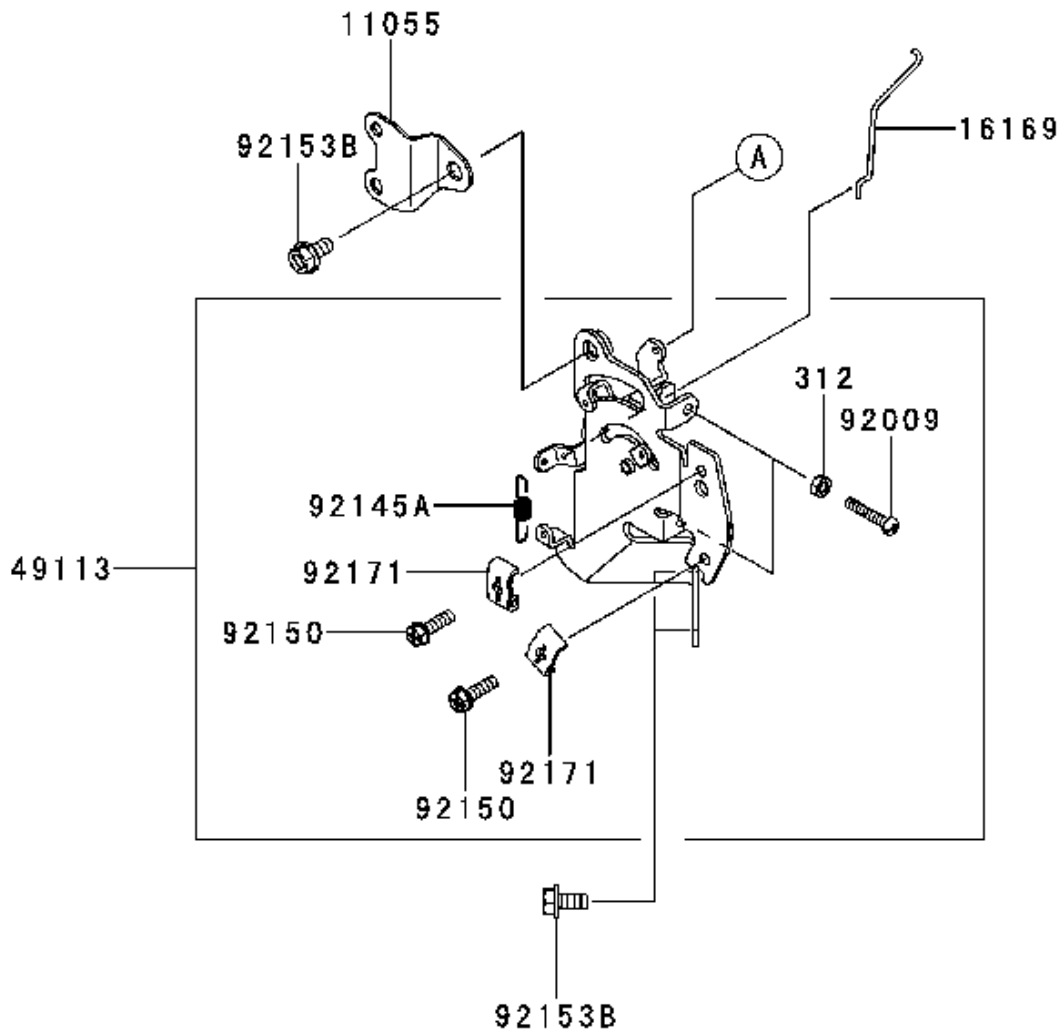

CONTROLS

KAWASAKI ENGINES, FX801V-FS00, 2017-09

Ref	Part No	Description	Remark	QTY KIT
11055	577 68 15-01	BRACKET	BRACKET	1
13107	577 74 12-01	SHAFT	SHAFT	1
13271	577 57 12-01	PLATE	PLATE	1
16169	582 76 34-01	LINK	LINK-CHOKE	1
16171	591 45 75-21	LINK	LINK	1
311	577 57 62-01	NUT	NUT-HEX,6MM	1
312	577 57 63-01	NUT	NUT-HEX	2
39129	591 45 76-13	SPRING	SPRING-GOVERNOR	1
411	577 57 64-01	WASHER	WASHER- PLAIN,6.5X13X1	1
49103	577 68 20-01	ARM	ARM-GOVERNOR	1
49103A	577 74 13-01	ARM	ARM-GOVERNOR	1
49113	591 45 75-36	PANEL	PANEL-COMP-CONTROL	1
92009	577 57 18-01	SCREW	SCREW,5X30	2
92145	591 45 76-10	SPRING	SPRING	1
92145A	577 68 23-01	SPRING	SPRING	1
92150	921 50 21-82	BOLT	BOLT	2
92153	577 68 25-01	BOLT	BOLT,FLANGED,6X12	1
92153A	577 68 26-01	BOLT	BOLT,6X35	1
92153B	577 58 20-01	BOLT	BOLT,6X12	3
92171	577 57 21-01	CLAMP	CLAMP	2
92172	577 68 27-01	SCREW	SCREW,4X8	2

E0150-B260A

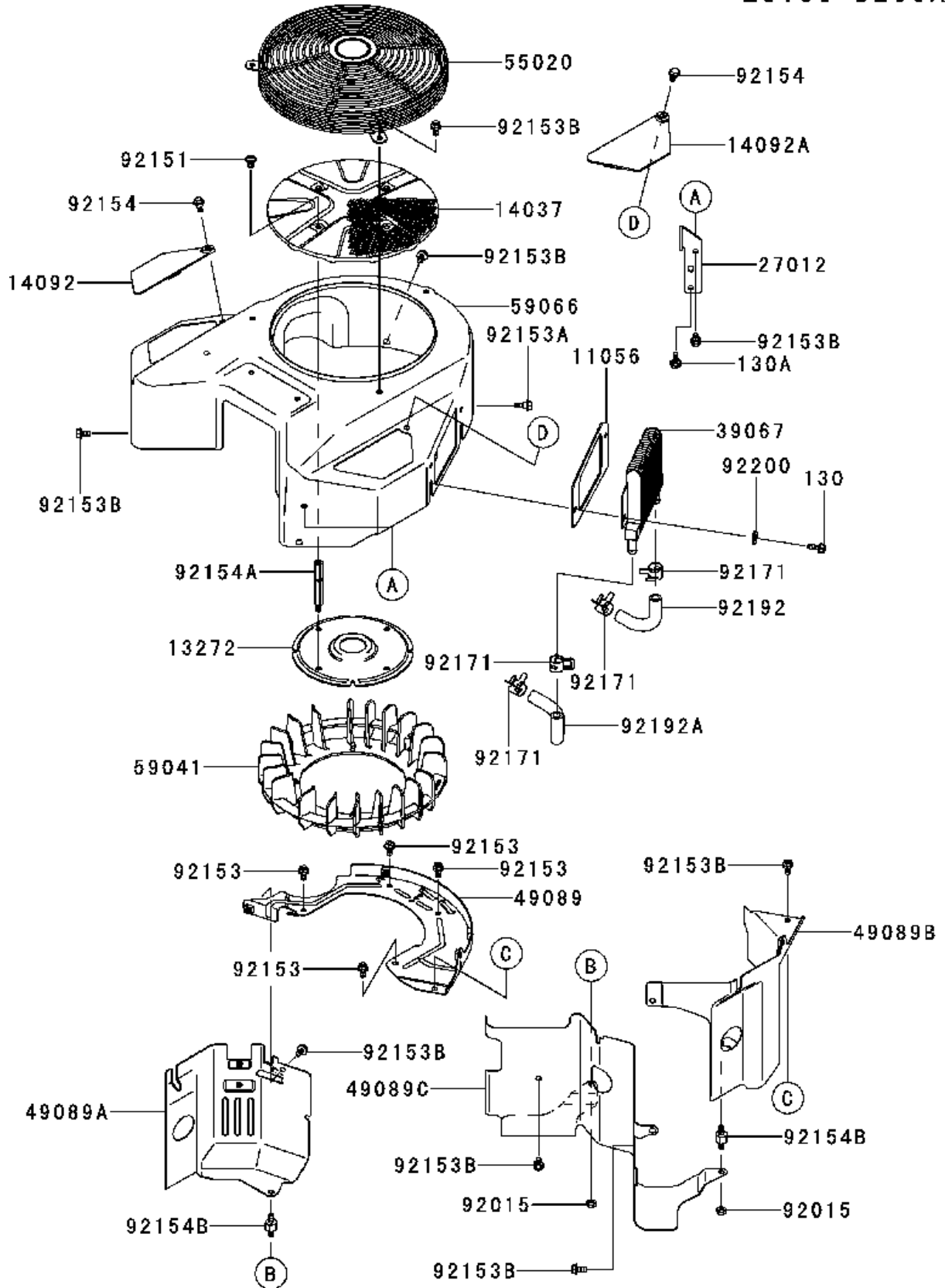

COOLING SYSTEM

KAWASAKI ENGINES, FX801V-FS00, 2017-09

Ref	Part No	Description	Remark	QTY KIT
11056	592 73 97-08	BRACKET	BRACKET	1
130	591 45 74-15	BOLT	BOLT-FLANGED,6X16	2
130A	591 45 74-16	BOLT	BOLT-FLANGED,6X20	1
13272	591 45 75-51	PLATE	PLATE	1
14037	577 56 78-01	SCREEN	SCREEN	1
14092	591 45 74-48	COVER	COVER	1
14092A	591 45 74-49	COVER	COVER	1
27012	591 45 74-95	HOOK	HOOK,LIFT	1
39067	591 45 74-47	COOLER	COOLER-OIL	1
49089	591 45 76-05	SHROUD	SHROUD-ENGINE,BACK	1
49089A	592 73 97-34	SHROUD	SHROUD-ENGINE,#1	1
49089B	592 73 97-31	SHROUD	SHROUD-ENGINE,#2	1
49089C	577 68 34-01	SHROUD	SHROUD-ENGINE,V-BANK	1
55020	577 56 82-01	GUARD	GUARD	1
59041	577 56 84-01	FAN	FAN	1
59066	591 45 75-01	HOUSING	HOUSING-FAN	1
92015	577 58 08-01	NUT	NUT,FLANGED,6MM	2
92151	577 68 36-01	BOLT	BOLT,6X12	4
92153	577 68 37-01	BOLT	BOLT,FLANGED,6X12	4
92153A	921 53 70-07	BOLT	BOLT,RECOIL STARTER	1
92153B	577 58 20-01	BOLT	BOLT,6X12	10
92154	591 45 74-10	BOLT	BOLT	2
92154A	591 45 74-11	BOLT	BOLT	4
92154B	591 45 74-12	BOLT	BOLT	2
92171	591 45 74-43	CLAMP	CLAMP	4
92192	591 45 76-18	TUBE	TUBE	1
92192A	591 45 76-19	TUBE	TUBE	1
92200	591 45 76-33	WASHER	WASHER,6.5X18X2.0	2

E0110-A921B

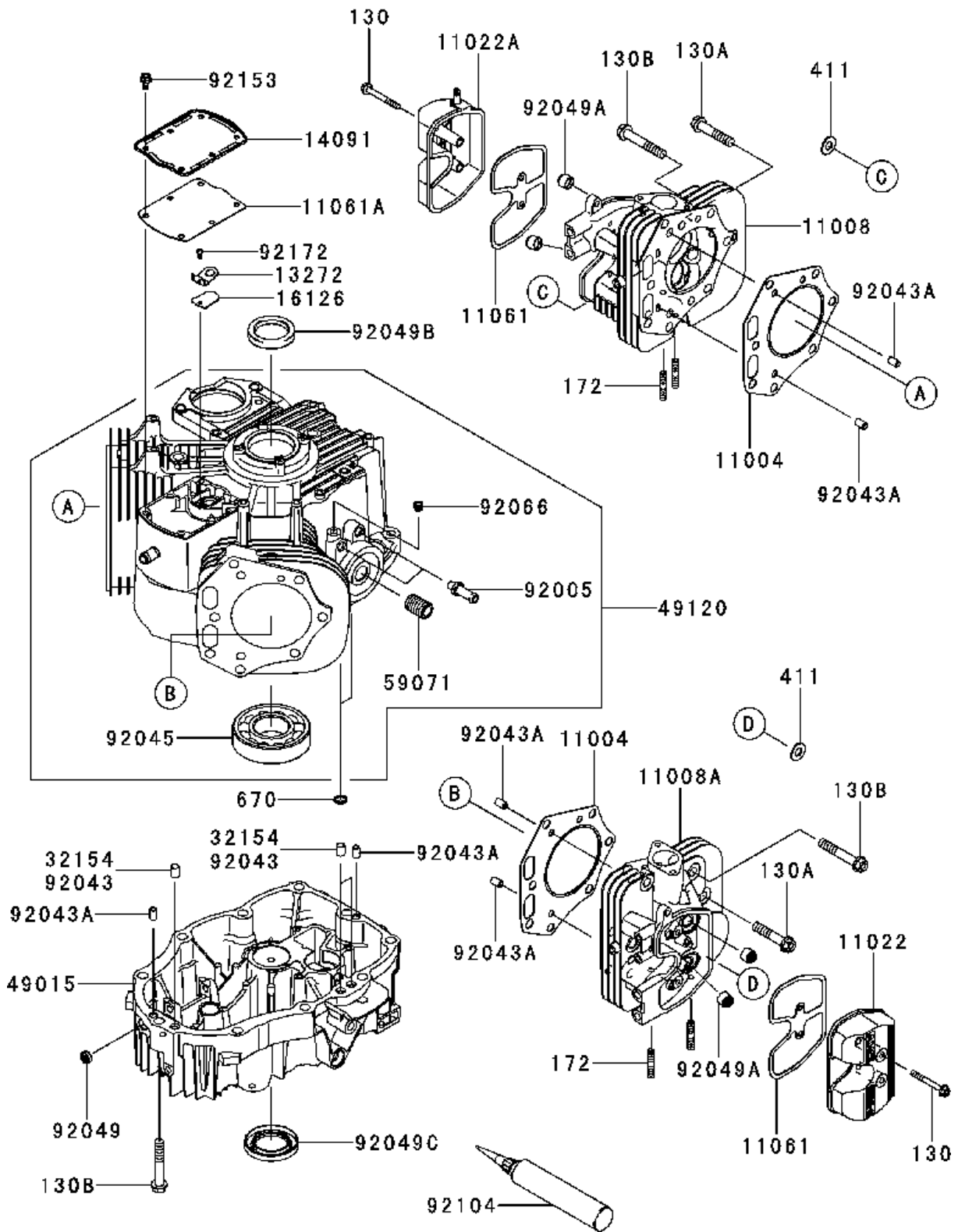

CYLINDER & CRANKCASE

KAWASAKI ENGINES, FX801V-FS00, 2017-09

Ref	Part No	Description	Remark	QTY KIT
11004	577 68 41-01	GASKET	GASKET-HEAD	2
11008	592 73 97-01	CYLINDER HEAD	HEAD-COMP-CYLINDER,#1	1
11008A	592 73 97-02	CYLINDER HEAD	HEAD-COMP-CYLINDER,#2	1
11022	591 45 74-41	CASE	CASE-ROCKER,#2	1
11022A	591 45 74-39	CASE	CASE-ROCKER,#1	1
11061	590 60 17-01	GASKET	GASKET	2
11061A	577 69 22-01	GASKET	GASKET,BREATHER	1
130	591 45 74-18	BOLT	BOLT-FLANGED	4
130A	577 69 24-01	BOLT	BOLT-FLANGED,10X50	2
130B	577 69 25-01	BOLT	BOLT-FLANGED,10X60	20
13272	586 59 38-01	PLATE	PLATE	1
14091	577 69 27-01	COVER	COVER,BREATHER	1
16126	577 69 28-01	VALVE	VALVE,BREATHER	1
172	591 45 74-22	BOLT	BOLT-STUD,8X22	4
32154	591 45 75-38	PIN	PIN	
411	577 69 29-01	WASHER	WASHER-PLAIN,10MM	2
49015	577 74 16-01	COVER	COVER-CRANKCASE	1
49120	591 45 74-55	CRANKCASE	CRANKCASE-COMP	1
59071	591 45 75-10	JOINT	JOINT	1
670	577 69 33-01	O-RING	""O"" RING"	2
92005	591 45 74-64	FITTING	FITTING	2
92043	591 45 75-38	PIN	PIN	3
92043A	586 52 44-01	PEN	PIN,DOWEL,6.2X8X14	6
92045	591 45 74-08	BEARING	BEARING-BALL,6308	1
92049	586 44 16-01	SEAL	SEAL-OIL,SO 8X14X5 HS	1
92049A	577 56 20-01	SEAL	SEAL-OIL	4
92049B	577 56 21-01	SEAL	SEAL-OIL,SD 40X54X9 R	1
92049C	577 69 35-01	SEAL	SEAL-OIL,SD 40X62X8 L	1
92066	586 62 16-01	PLUG	PLUG	1
92104	586 59 40-01	GASKET	GASKET-LIQUID,TB1217H	
92153	577 58 20-01	BOLT	BOLT,6X12	6
92172	591 45 75-79	SCREW	SCREW,4X8	1
Not shown	591 45 75-93	SHORT BLOCK ASSY	ENGINE,SHORT BLOCK	1

F0290--B743A

56014



56033

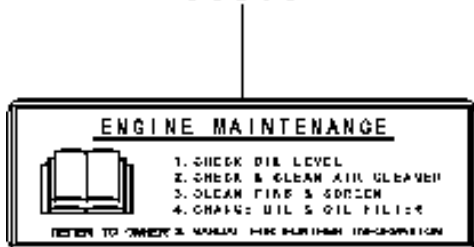

56071



DECALS

KAWASAKI ENGINES, FX801V-FS00, 2017-09

Ref	Part No	Description	Remark	QTY KIT
56014	591 45 74-62	DECAL	EMBLEM	1
56033	577 58 45-01	LABEL	LABEL-MANUAL	1
56071	586 59 43-01	LABEL	LABEL-WARNING	1

E0160-B802A

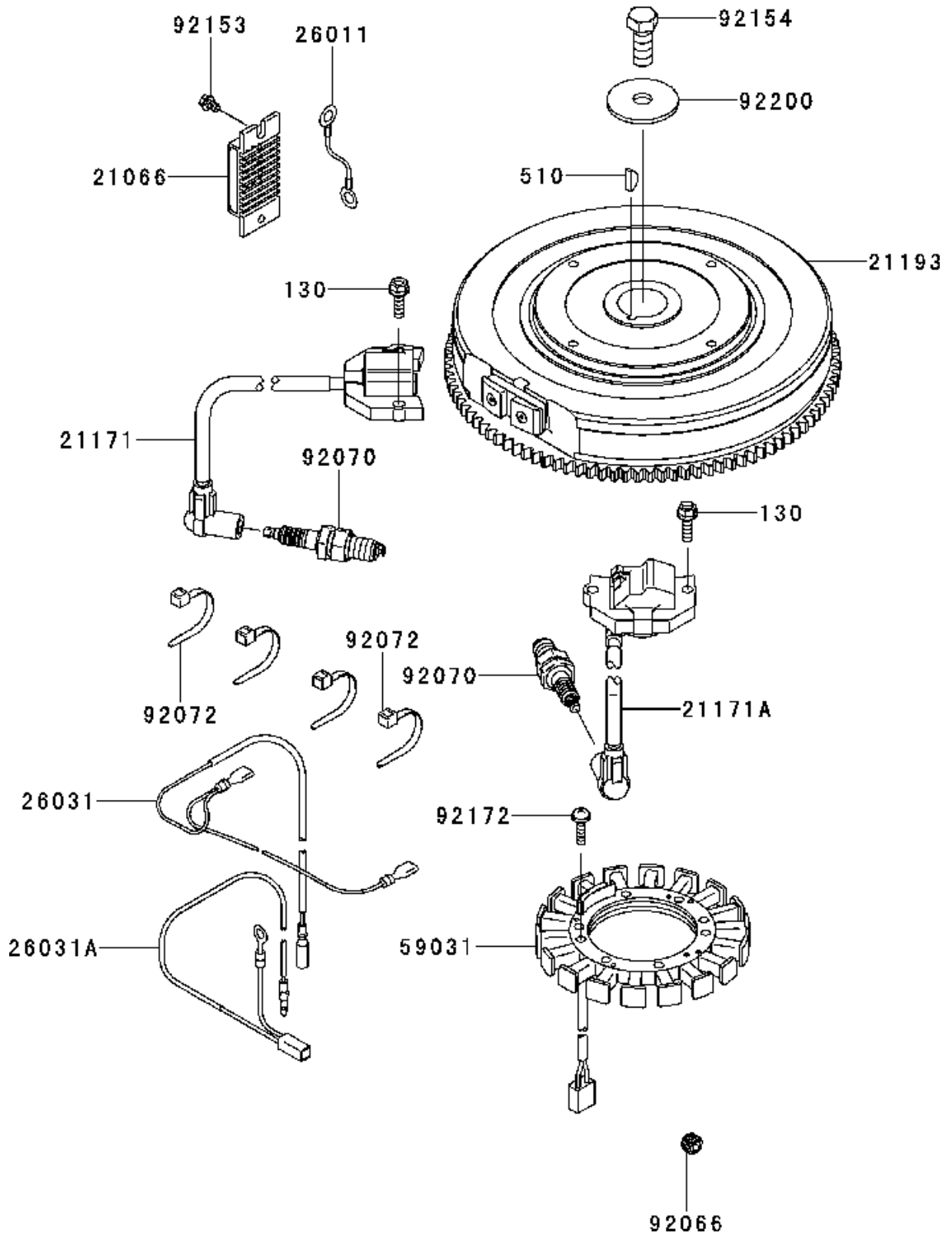

ELECTRICAL

KAWASAKI ENGINES, FX801V-FS00, 2017-09

Ref	Part No	Description	Remark	QTY KIT
130	591 45 74-16	BOLT	BOLT-FLANGED,6X20	4
21066	591 45 75-58	REGULATOR	REGULATOR-VOLTAGE	1
21171	586 52 50-02	COIL	COIL-ASSY-IGNITION	1
21171A	591 45 74-46	COIL	COIL-ASSY-IGNITION	1
21193	591 45 74-65	FLYWHEEL	FLYWHEEL-ASSY	1
26011	591 45 76-35	WIRE	WIRE-LEAD	1
26031	577 57 00-01	HARNESS	HARNESS	1
26031A	577 57 01-01	HARNESS	HARNESS	1
510	502 81 16-01	WOODRUFF KEY	WOODRUFF KEY	1
59031	577 57 02-01	COIL	COIL-CHARGING 15AMP	1
92066	586 62 16-01	PLUG	PLUG	1
92070	578 18 15-01	SPARK PLUG	PLUG- SPARK,BPR4ES(NGK)	2
92072	577 57 04-01	BAND	BAND	4
92153	577 69 40-01	BOLT	BOLT	2
92154	577 57 05-01	BOLT	BOLT,12X30	1
92172	577 57 06-01	SCREW	SCREW,5X20	4
92200	577 57 07-01	WASHER	WASHER,12.2X46X3	1

E0200-A886A

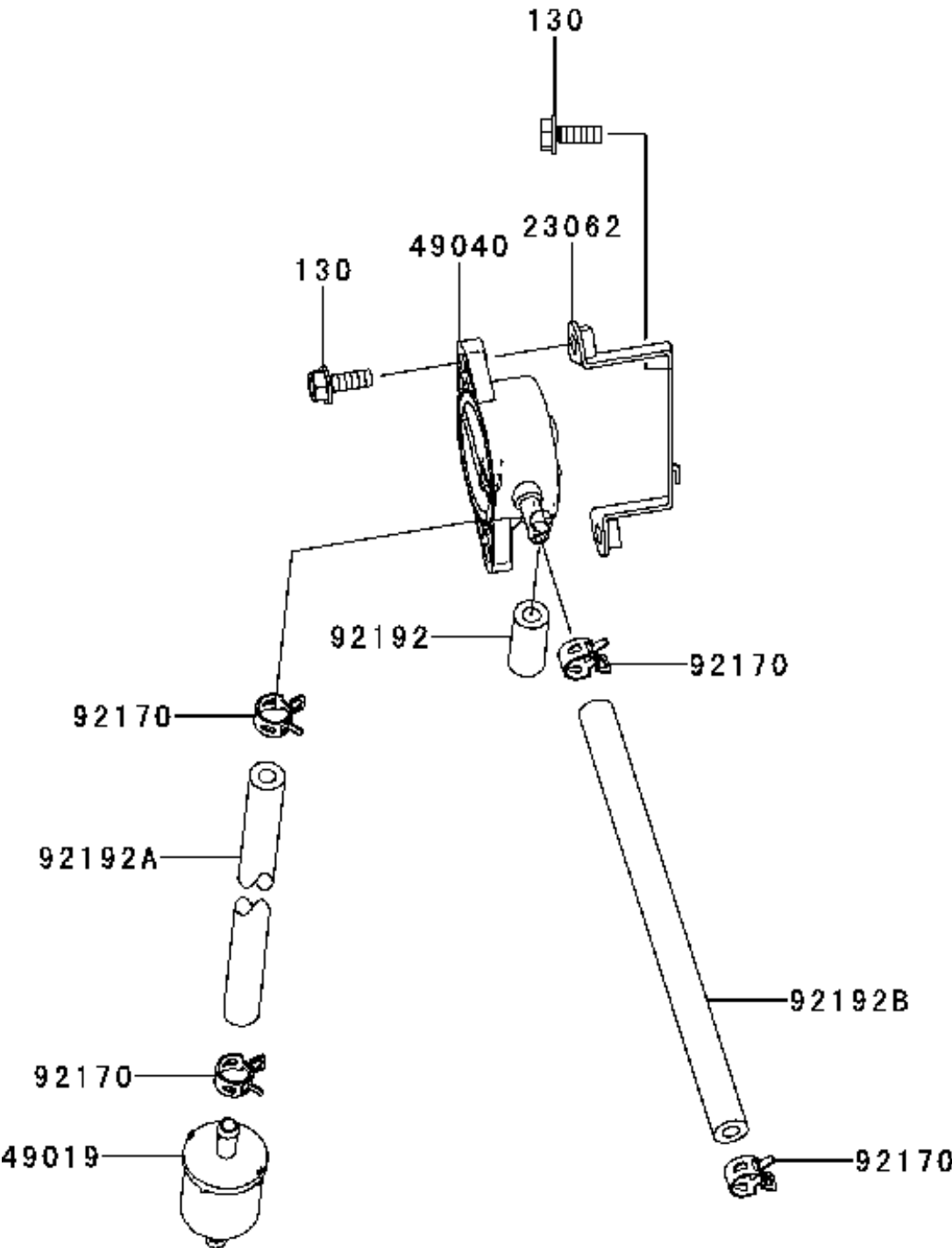

FUEL VALVE

KAWASAKI ENGINES, FX801V-FS00, 2017-09

Ref	Part No	Description	Remark	QTY KIT
130	591 45 74-15	BOLT	BOLT-FLANGED,6X16	3
23062	577 69 41-01	BRACKET	BRACKET-COMP	1
49019	582 54 12-01	FUEL FILTER	FILTER-FUEL	1
49040	490 40 70-01	FUEL PUMP	PUMP-FUEL	1
92170	577 58 21-01	CLAMP	CLAMP	4
92192	577 69 42-01	TUBE	TUBE,6.4X12.7X28.5	1
92192A	592 73 97-47	TUBE	TUBE,6.35X12.7X140	1
92192B	592 73 97-48	TUBE	TUBE,6.35X12.7X195	1

E0140-A450C

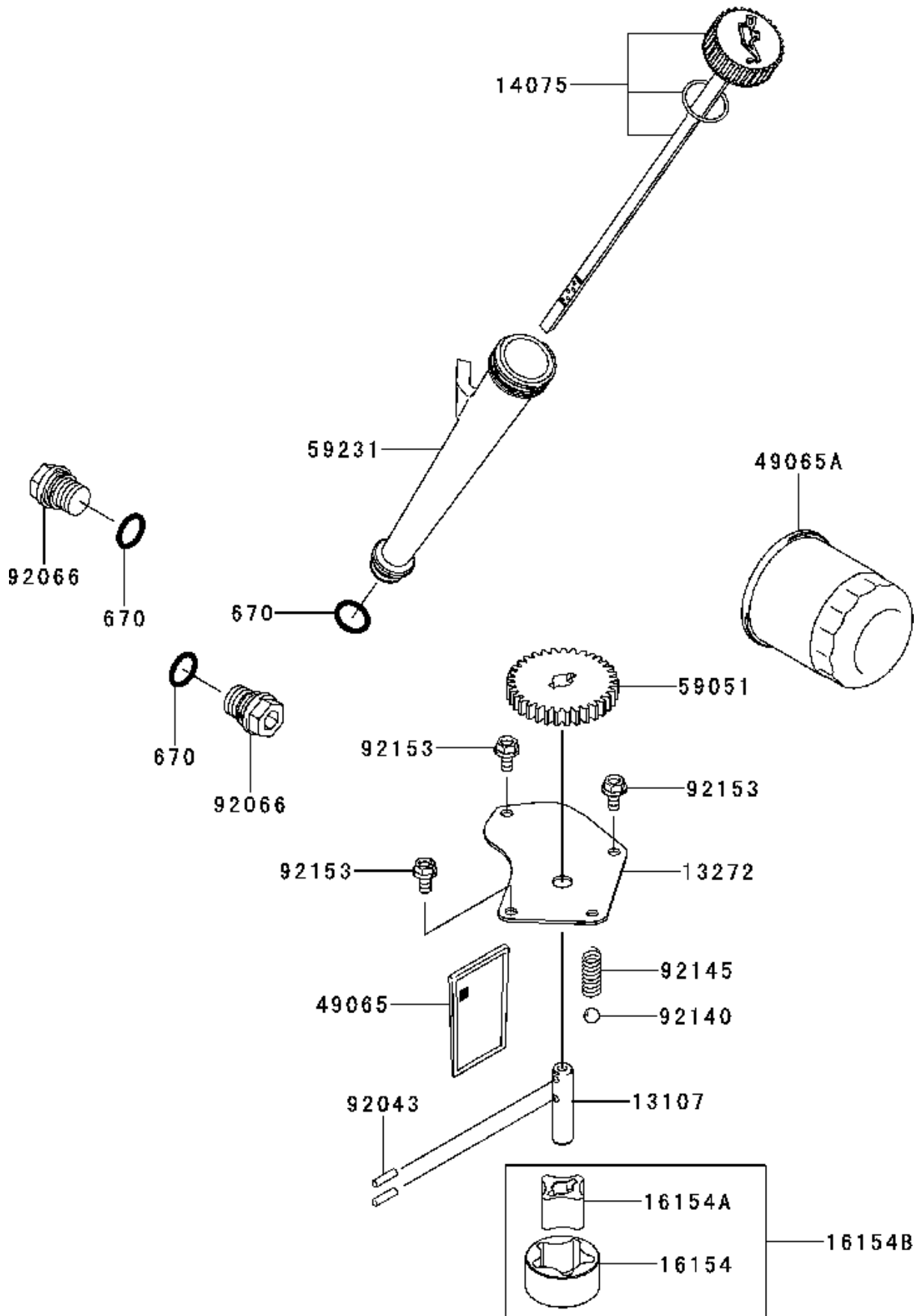

LUBRICATION

KAWASAKI ENGINES, FX801V-FS00, 2017-09

Ref	Part No	Description	Remark	QTY KIT
13107	591 45 75-84	SHAFT	SHAFT	1
13272	592 73 97-21	PLATE	PLATE,OIL PUMP	1
14075	591 45 74-27	CAP	CAP-ASSY	1
16154	577 69 52-01	ROTOR	ROTOR-PUMP,OUTER	1
16154A	577 69 53-01	ROTOR	ROTOR-PUMP,INNER	1
16154B	577 69 54-01	ROTOR	ROTOR-PUMP	1
49065	490 65 70-04	FILTER OIL	FILTER-OIL	1
49065A	576 81 05-01	AIR FILTER	FILTER-OIL	1
59051	590 51 70-11	GEAR-SPUR	GEAR-SPUR	1
59231	577 69 55-01	FILLER	FILLER	1
670	502 82 90-01	O-RING	O RING	3
92043	920 43 70-03	PEN	PIN	2
92066	591 45 75-54	PLUG	PLUG	2
92140	921 40 70-03	BALL	BALL	1
92145	591 45 76-12	SPRING	SPRING	1
92153	577 58 20-01	BOLT	BOLT,6X12	3

E0120-A485A

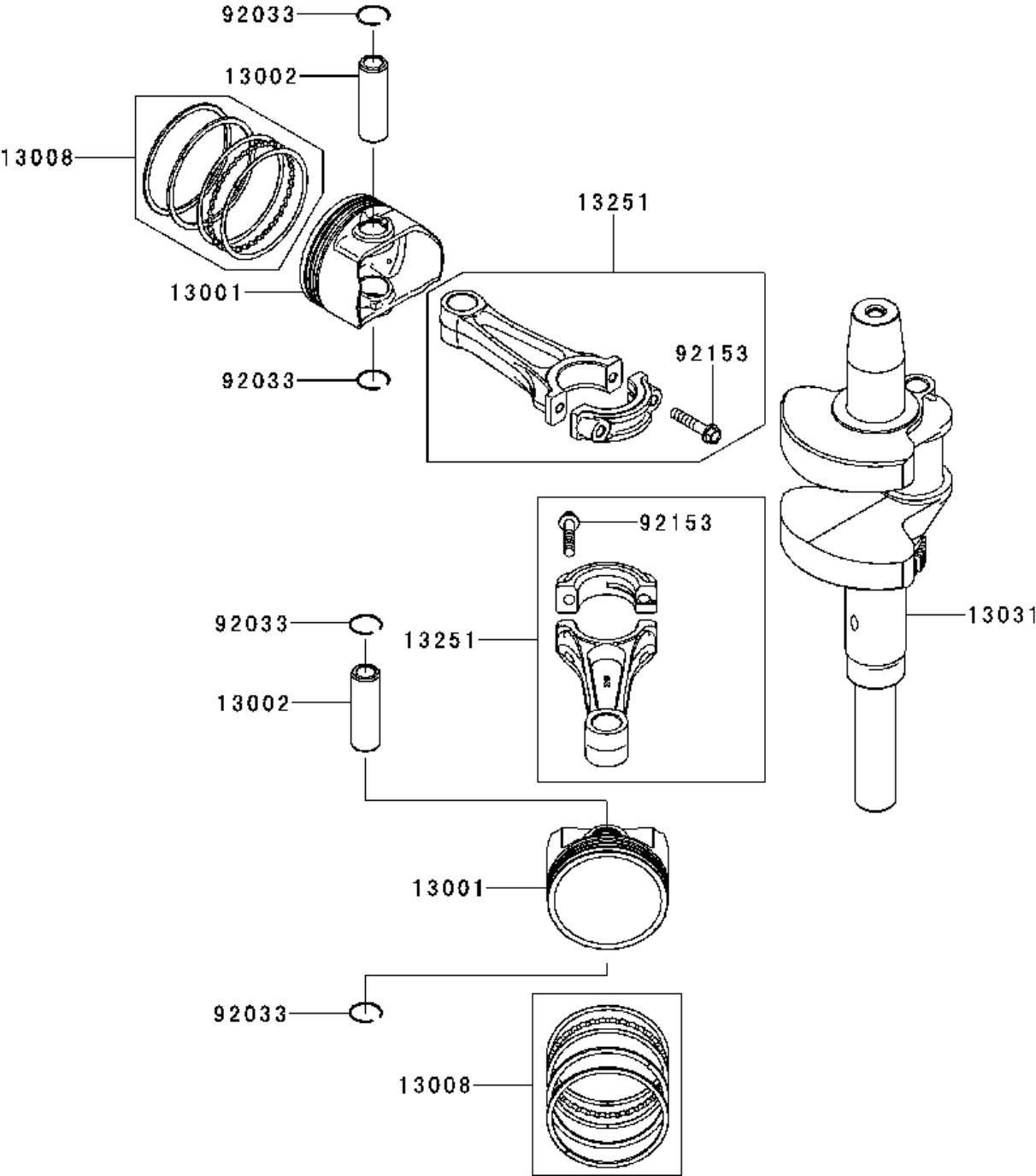

PISTON & CRANKSHAFT

KAWASAKI ENGINES, FX801V-FS00, 2017-09

Ref	Part No	Description	Remark	QTY KIT
13001	577 69 56-01	PISTON	PISTON-ENGINE	2
13002	577 69 57-01	PEN	PIN-PISTON	2
13008	577 69 58-01	RING	RING-SET-PISTON	2
13031	592 73 97-17	CRANKSHAFT	CRANKSHAFT-COMP	1
13251	591 45 75-73	ROD	ROD-ASSY-CONNECTING	2
92033	591 45 75-65	RING	RING-SNAP	4
92153	577 56 41-01	BOLT	BOLT	4

E0210-A479A

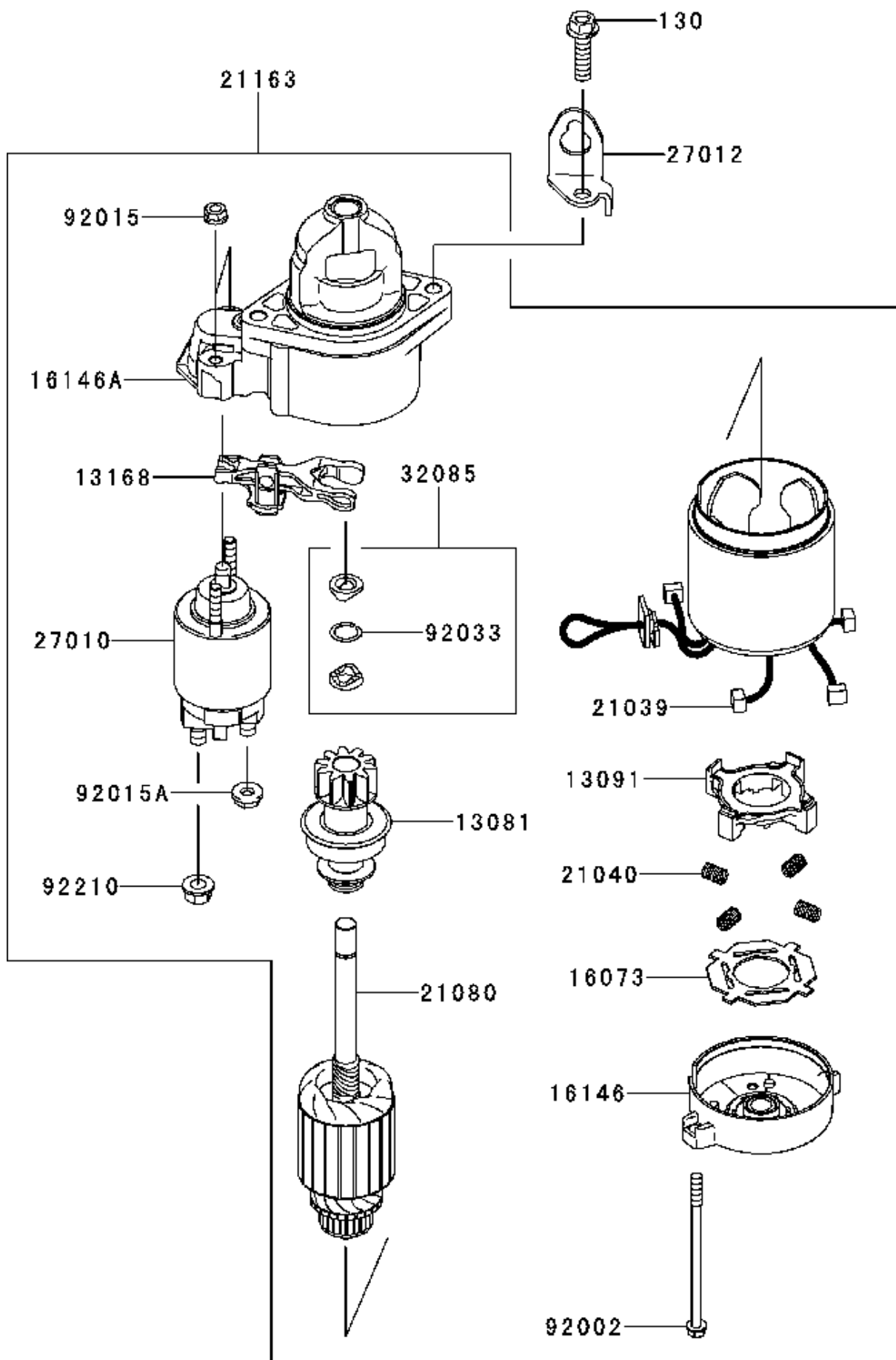

STARTER

KAWASAKI ENGINES, FX801V-FS00, 2017-09

Ref	Part No	Description	Remark	QTY KIT
13081	577 58 29-01	CLUTCH	CLUTCH-ASSY	1
13091	130 91 20-68	HOLDER	HOLDER-BRUSH	1
130	591 45 74-20	BOLT	BOLT-FLANGED,8X30	2
13168	577 58 30-01	LEVER	LEVER	1
16073	577 58 31-01	INSULATOR	INSULATOR	1
16146	577 58 32-01	COVER	COVER ASSY	1
16146A	577 58 33-01	COVER	COVER-ASSY	1
21039	210 39 20-59	BRUSH	BRUSH	4
21040	210 40 20-52	SPRING	SPRING-BRUSH	4
21080	577 58 35-01	SHAFT	ARMATURE	1
21163	592 73 97-52	STARTER	KIT,STARTER-ELECTRIC	1
27010	577 58 37-01	SWITCH	SWITCH	1
27012	577 69 67-01	HOOK	HOOK,LIFT	1
32085	577 58 38-01	STOPPER	STOPPER	1
92002	577 58 39-01	BOLT	BOLT	2
92015	577 58 40-01	NUT	NUT	2
92015A	577 58 41-01	NUT	NUT	1
92033	577 20 93-01	RING	RING-SNAP	1
92210	577 58 42-01	NUT	NUT	1

E0130-A226B

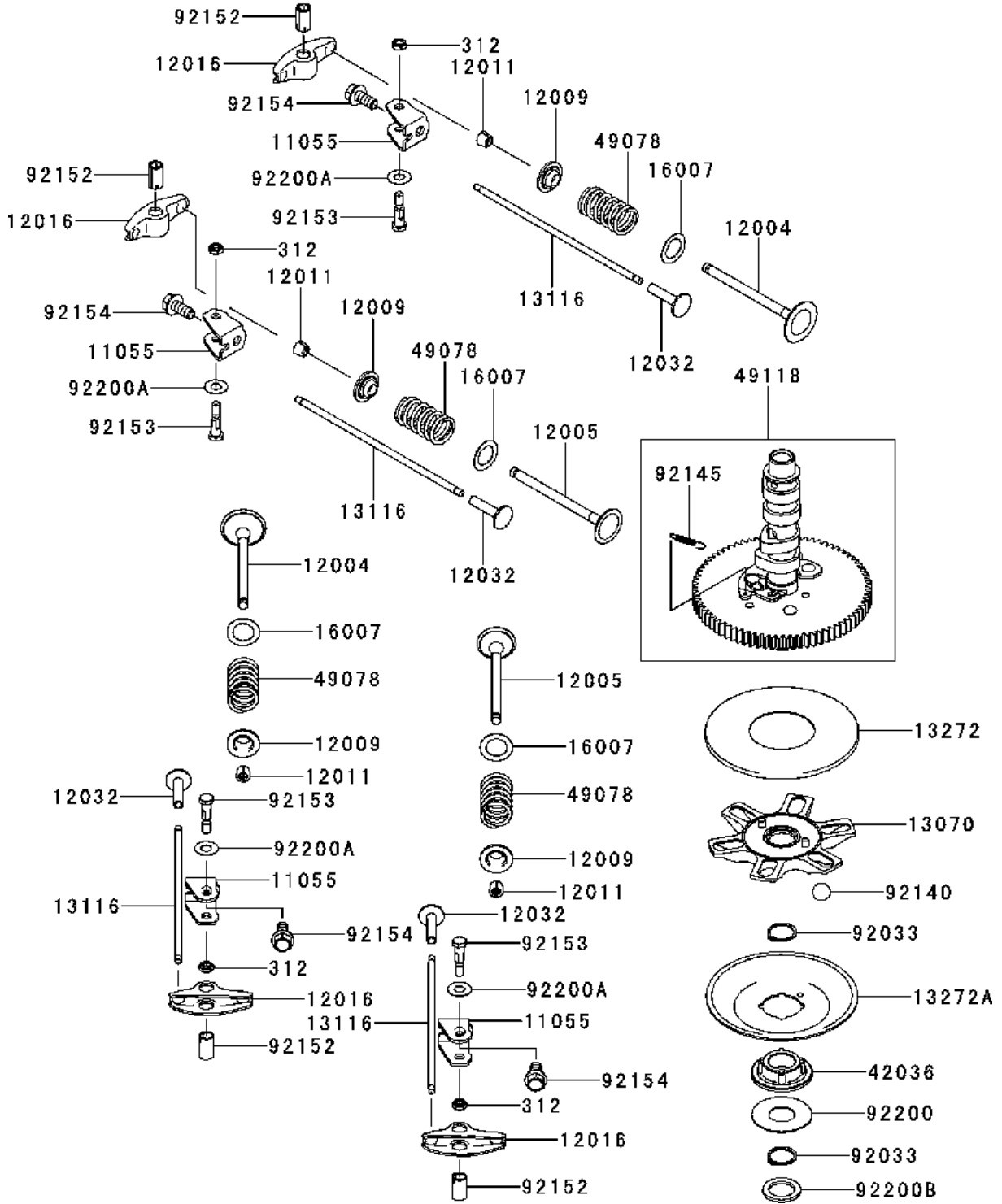

VALVE & CAMSHAFT

KAWASAKI ENGINES, FX801V-FS00, 2017-09

Ref	Part No	Description	Remark	QTY KIT
11055	577 69 72-01	BRACKET	BRACKET	4
12004	592 73 97-10	VALVE	VALVE-INTAKE	2
12005	592 73 97-12	VALVE	VALVE-EXHAUST	2
12009	577 56 46-01	VALVE	RETAINER-VALVE SPRING	4
12011	577 56 49-01	COLLET	COLLET	8
12016	592 73 97-13	ARM	ARM-ROCKER	4
12032	120 32 70-01	TAPPET	TAPPET	4
13070	591 45 74-86	GUIDE	GUIDE	1
13116	577 69 78-01	ROD	ROD-PUSH	4
13272	577 69 79-01	PLATE	PLATE	1
13272A	577 69 80-01	PLATE	PLATE,GOVERNOR	1
16007	591 45 75-83	SEAT	SEAT-SPRING	4
312	577 69 81-01	NUT	NUT-HEX	4
42036	577 69 82-01	SLEEVE	SLEEVE	1
49078	577 74 09-01	SPRING	SPRING-ENGINE VALVE	4
49118	577 74 10-01	CAMSHAFT	CAMSHAFT-COMP	1
92033	591 45 75-68	RING	RING-SNAP	2
92140	577 56 68-01	BALL	BALL	6
92145	591 45 76-11	SPRING	SPRING	1
92152	586 55 13-01	COLLAR	COLLAR	4
92153	577 69 87-01	BOLT	BOLT,6X29.5	4
92154	591 45 74-13	BOLT	BOLT	4
92200	591 45 76-32	WASHER	WASHER,20X46X0.91	1
92200A	577 69 88-01	WASHER	WASHER,8.1X18X0.5	4
92200B	577 69 89-01	WASHER	WASHER,20.3X29X2.28	1